



Operating and Maintenance Manual

for the

PortaBELL™ III

Dental Field Treatment and Operating System III

Revision A
April 2007

Bell Dental Products, LLC
3003 Arapahoe St., 101B
Denver, CO 80205

Reorder PN 4202053

TABLE OF CONTENTS

1.0 INTRODUCTION	4
1.1 Safety Precautions	4
1.2 Summary of Key Operation and Maintenance Activities	5
1.3 System Description	6
1.4 Principles of Operation	7
1.4.1 Electric Power Subsystem	17
1.4.2 Electronic Control Subsystem	20
1.4.3 Air Supply Subsystem	21
1.4.4 Water Supply Subsystem	21
1.4.5 Vacuum Supply Subsystem	22
2.0 SET-UP	23
3.0 OPERATION	31
4.0 PACKING THE UNIT FOR SHIPPING AND STORAGE	34
5.0 MAINTENANCE	40
5.1 Periodic Maintenance	40
5.2 Sterilization and Disinfection	41
5.3 Cleaning	41
5.3.1 Motor	41
5.3.2 Hand Pieces	43
5.3.3 Waste container and waste container top	45
5.3.4 Vacuum Hoses	45
5.3.5 Vacuum Water Trap	45
5.3.6 Water Reservoir and Water Lines	45
5.3.7 Base Unit and Control Panel	45
5.3.8 Instrument Tray	45
5.4 Draining the Water Traps	45
5.4.1 Draining the Compressor Water Trap	46
5.4.2 Draining the Vacuum Water Trap	46
5.5 Cleaning or Replacing the Filter Elements	46
5.5.1 Replacing the Water Line Filter Element (PN 9100010)	46
5.5.2 Replacing the Vacuum Line Water Trap Filter Element (PN 9100258)	47
5.5.3 Replacing the Compressor Water Trap Filter Element	47
5.5.4 Replacing the Compressor Inlet Filter Element	47
5.5.5 Cleaning the Cooling Air Filter Elements	48
5.5.6 Replacing the Cooling Air Filter Elements	48
5.6 Replacing the Fiber Optic Lamp	49
5.7 Checking the Suction System	49
5.8 Adjustments and Calibration	50
5.8.1 Voltage to the Hand Piece Motor	50
5.8.2 Motor Speed Indication	51
5.8.3 Regulated Pressure	53
5.8.4 Compressor Pressure Relief	54
5.8.5 Checking Cooling Air Flow to the Motor	54
5.9 Removing and Replacing the Main Circuit Board	55
5.10 Removing Tubing From Push-in Fittings	56
6.0 TROUBLESHOOTING	57
6.1 Motor and Hand Piece	57
6.2 Vacuum Supply Subsystem	58
6.3 Air and Water Supply Subsystems	59
6.4 Electronics	60
7.0 MAJOR SYSTEM COMPONENTS	66

7.1 Water Subsystem Components.....	66
7.2 Major Components - Base Unit.....	67
7.3 Major Components – Top of Unit.....	68
8.0 WARRANTY.....	69
9.0 CUSTOMER SERVICE.....	69
10.0 SPECIFICATIONS.....	70
APPENDIX A – System Parts List.....	71
APPENDIX B – Schematics and Parts Lists.....	81
Main Circuit Board Schematics.....	82
Main Circuit Board Layout.....	86
Main Circuit Board Parts List.....	87
Keypad Circuit Board LEDs Schematic.....	89
Keypad Circuit Board Buttons Schematic.....	90
Keypad Circuit Board Parts List.....	91
Voltage Control Circuit Board Schematic.....	92
Voltage Control Circuit Board Layout.....	93
Voltage Control Circuit Board Parts List.....	94
APPENDIX C - Main Circuit Board Connector Test Point Values.....	95
APPENDIX D - BIEN AIR ELECTRIC HANDPIECE MAINTENANCE.....	97
APPENDIX E - Sterilization and Maintenance Instructions For Motor and Hand Pieces.....	98
APPENDIX F – Acceptance Test Record.....	100

1.0 INTRODUCTION

This Operating and Maintenance Manual describes the set-up, operation, maintenance, and troubleshooting of the PortaBELL™ III Dental Field Treatment and Operating System (DeFTOS).

NOTE

The PortaBELL™ III is a prescription device. Federal law restricts the sale to or on the order of a dentist.

1.1 Safety Precautions

Only personnel who have completed a course in the operation and maintenance of this equipment are authorized to set-up, operate, maintain, and repair the equipment. All personnel should carefully review this manual before performing any operation. A list of safety precautions is presented in Table 1.1-1.

Table 1.1-1

Safety Precautions

What to Look For	Safety Concern	What To Do
Hot parts	The vacuum pump and compressor heads and motor can become hot when operated for an extended time.	Do not touch the vacuum pump or compressor. Allow unit to cool at least 60 minutes, with cooling fan running, before performing service.
Electricity	Electric shock	Never use the system directly in rain or wet conditions. Always unplug the system before performing any maintenance or repair. Verify the system is properly grounded. Make sure the frequency of the load connected to the duplex outlet and the mains power are the same
Flammable vapors	As with an air compressor for an air driven system, operation of the system in the presence of flammable vapors can create a fire or explosion hazard.	Use only in well ventilated areas
Fire	The frequency of any load connected to the duplex outlet must match the mains frequency. If they are different it may cause the load and/or step down transformer to over heat.	Make sure the frequency of the load connected to the duplex outlet and the mains power are the same

1.2 Summary of Key Operation and Maintenance Activities

This section presents the key points that a DeFTOS operator and supporter should be aware of.

The motor will go to full speed when the Panel/Foot Switch control is switched to foot switch if the foot switch is not connected.

The vacuum pump may not restart if there is a vacuum on the vacuum line, make sure the waste container is connected to the system.

The compressor may not restart if there is pressure in the outlet line, make sure the pressure is bled off

DO NOT autoclave the motor.

If a sudden loss of vacuum is experienced it is probably caused by a full waste container.

If there is low suction it is probably caused by a leak or loose connection.

Check filters and water traps at the end of each day.

If the hand piece leaks from the motor, tighten the hose connection at the base of the motor, hand tighten only, DO NOT use any tool.

If the hand piece leaks from the interface with the motor, replace the motor o-rings.

Take care to connect the motor hose to the motor, the threads are very fine and easy to cross thread.

Take care when connecting the motor tubing to the base unit, the locking collar locks with only a 1/16 turn click.

Take care when connecting the foot switch to the base unit, the locking collar locks with only ¼ turn.

Take care when removing the main circuit board to avoid damage to the control panel label. The control panel label is “taped” to the button control circuit board with an adhesive. The button control circuit board is connected to the main circuit board via 2 connectors. Carefully unplug the main circuit board from the button circuit board to avoid damaging the label.

If the 3-way syringe does not work, check the installation of the valve in the handle, make sure it is fully inserted into the handle and locked with a twist.

© 2006 Bell Dental Products, LLC. All rights reserved. No portion may be copied or reproduced without express written permission from Bell Dental Products, LLC.

The compressor bleed valve will make a hissing noise immediately after the compressor is turned OFF.

Make sure the frequency of any load connected to the duplex outlet is the SAME AS the main power frequency.

The power rating of the duplex outlet is 100VA.

The hand piece motor will get warm if the fiber optics is used continuously because the fiber optic bulb is mounted in the motor housing.

The hand piece motor requires cooling air. Motor damage may result if the motor is operated for extended periods without cooling airflow. If cooling air to the motor is lost the Low Cooling Air To Motor LED will come on and the motor will be disabled. To override the low cooling air and restart the motor, press the speed increase button. This will allow operation of the motor even if there is low cooling air to the motor. CAUTION, this may cause motor damage with extended motor operation. It is best to reestablish cooling airflow to the motor before resuming operation.

If the vacuum pump is left ON continuously the controller will turn it OFF if there is NO activity of the hand piece motor for approximately 12 minutes. It will then blink the Suction ON LED to indicate that the vacuum pump has been turned OFF automatically. To restart normal operation press the Suction ON button on the control panel.

It is possible for the vacuum shut-off valve in the waste container to activate prematurely and/or stick if it has not been cleaned completely. To restore flow if the valve activates prematurely you must release the vacuum on the valve. To release the vacuum just turn the vacuum pump OFF and open the HVE valve, this will allow the valve to OPEN.

1.3 System Description

The PortaBELL™ III DeFTOS is a state-of-the-art system utilizing the latest electric motor driven hand piece technology to meet the demanding needs of the modern mobile dentist.

The system incorporates all of the functionality to perform any dental procedure from cleaning to oral surgery. The system includes an electric motor, with or without fiber optics, high speed hand piece, low speed hand piece, air/water supply, air/water syringe, high volume evacuator (HVE), saliva ejector, and variable speed foot switch. In addition the system will support FDA approved 4-hole sonic scalers, like the Star Dental Titan scaler or equivalent..

The system is lightweight and totally self-contained. The system includes an oilless air compressor and vacuum pump that provides air to the water and air supply subsystems and suction for the saliva ejector and HVE, a self-contained water supply for hand piece coolant and oral irrigation, and a waste container for collection of liquids and solids from the HVE and saliva ejector. The system supports a variety of standard electric motors and all E-type connected hand pieces.

The system will operate on any power from 100VAC to 240VAC, 50 or 60 Hz without the need for a transformer.

The entire system can be quickly assembled or disassembled and packs into one molded shipping and storage container for safe transport and storage.

The system components are shown and identified in Figures 1.3-1 and 1.3-2.

1.4 Principles of Operation

The system is composed of an electric power subsystem, an electronic control subsystem, a compressed air subsystem, a water subsystem, and a vacuum subsystem. Each is described below.

The principle of operation is simple, refer to Figures 1.4-1 through 1.4-5, the compressor pressurizes the air storage tank. Compressed air is provided to the motor for cooling, the hand piece for chip air, the air/water syringe, and the water reservoir, refer to Figure 1.4-1. Water is forced from the water reservoir by the compressed air and flows to the hand piece and air/water syringe. Flow of the water and air to the motor and hand piece is controlled by solenoid valves and adjusted by needle valves, refer to Figures 1.4-1 and 1.4-2. Vacuum is provided by the vacuum pump. The vacuum pump is connected to the waste container. The waste container is connected to the HVE and saliva ejector, refer to Figure 1.4-3. Operation of the unit is controlled from the control panel. A description of the controls and connections is presented in Tables 1.4-1 and 1.4-2.

TABLE 1.4-1

DESCRIPTION OF THE CONTROL PANEL CONTROLS
(REFER TO FIGURE 1.4-4)

CONTROL	DESCRIPTION
HAND PIECE WATER FLOW ADJUST	Adjusts the flow of cooling water to the hand piece
HAND PIECE WATER ON/OFF	Turns power ON and OFF to the water solenoid
HAND PIECE AIR FLOW ADJUST	Adjusts the flow of chip air to the hand piece
HAND PIECE AIR ON/OFF	Turns power ON and OFF to the air solenoid
PANEL/FOOT SWITCH CONTROL	Switches operating mode for controlling motor speed between the foot switch and the control panel
COMPRESSOR ON/OFF	Turns power ON and OFF to the compressor
FIBER OPTICS ON/OFF	Turns power ON and OFF to the fiber optics
FIBER OPTIC INTENSITY	Control to adjust the intensity of the fiber optic light
MOTOR ON/OFF	Turns power ON and OFF to the motor
VACUUM ON/OFF	Turns power ON and OFF to the vacuum pump
MOTOR SPEED	Controls motor speed when in the PANEL operating mode
LOW AIRFLOW TO MOTOR	Indicates when there is low cooling airflow to the motor
POWER ON	Indicates when the main power is ON
MOTOR SPEED	Bar graph type indicator of the motor speed. 4 scales are presented, one for each of 4 different hand piece ratios; 1:5, 1:1, 2.7:1 and 10:1. Read the appropriate scale for the hand piece being used.

TABLE 1.4-2

DESCRIPTION OF BACK PANEL
(REFER TO FIGURE 1.4-5)

CONNECTION	DESCRIPTION
AUXILLIARY AIR INLET	Provides means to charge the air storage tank with compressed air from an external source
AIR STORAGE TANK MOTOR/HAND PIECE	Connection for hose to air storage tank Integrated connector for the motor power, fiber optics power, motor cooling air, hand piece cooling water, and hand piece chip air
SYRINGE	Connection for air line for air/water syringe
AIR	Connection for water line for air/water syringe
WATER	Connection for water from the water reservoir
WATER IN	Connection for compressed air out to the water reservoir
AIR OUT	Latches the top in place
COVER LATCH	Connection for vacuum line to the waste container
VACUUM OUT	Connector for the foot switch cable
FOOT SWITCH	Circuit breakers for both legs of power to the Duplex Outlet
AC RECEPTACLE CIRCUIT BREAKERS	Duplex Outlet, 120 VAC 50/60 HZ, 100 watts max.
AC RECEPTACLE	Frequency will be the same as the mains power.
MAINS CIRCUIT BREAKERS	Outlets are switched with main power switch and both legs are protected with circuit breaker
POWER SWITCH AND	Circuit breakers for both legs of mains power
POWER CORD CONNECTOR	Switches main power ON and OFF and connection for power cord

Figure 1.3-1

PortaBELL™III DeFTOS III Major Components

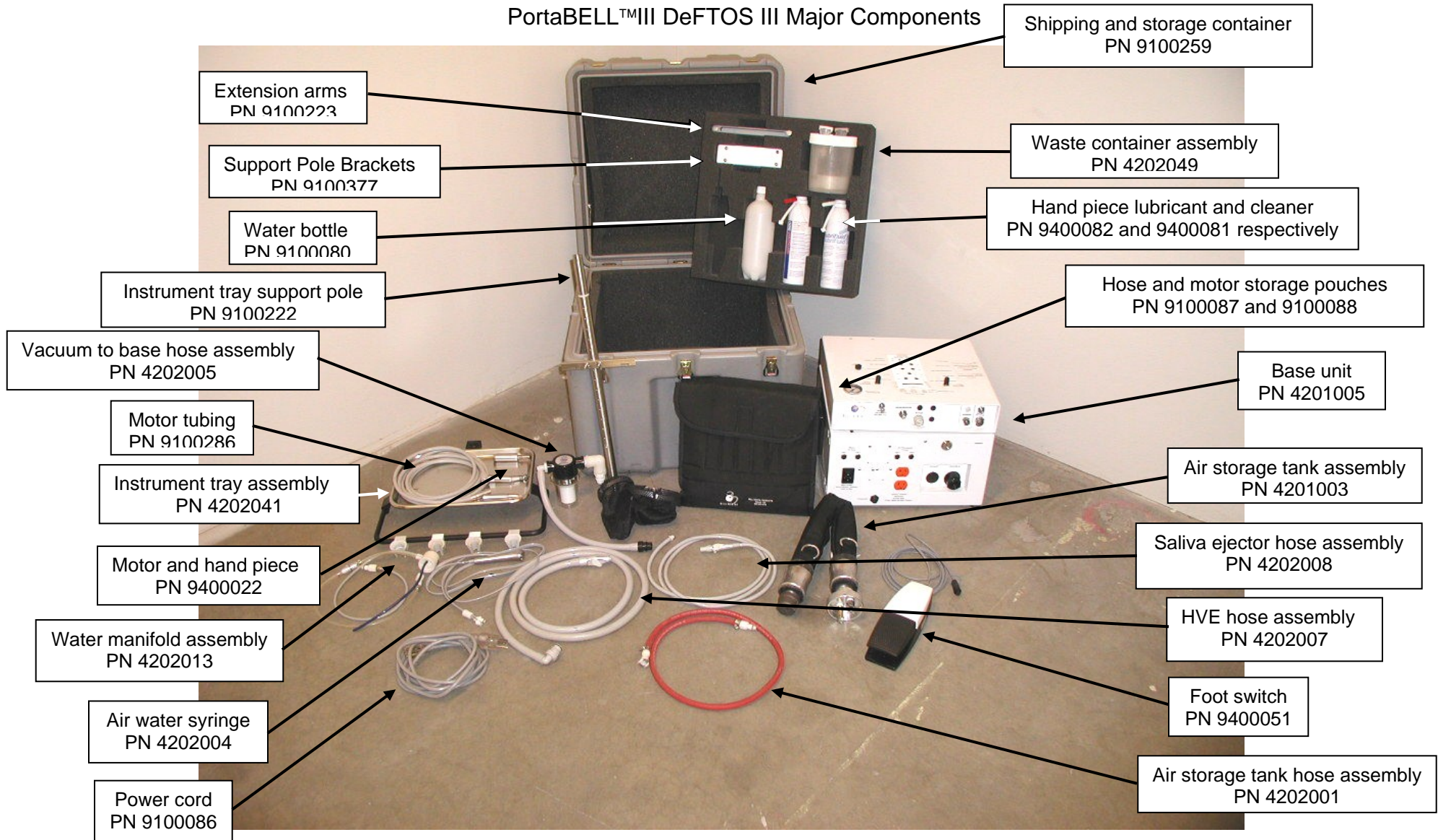
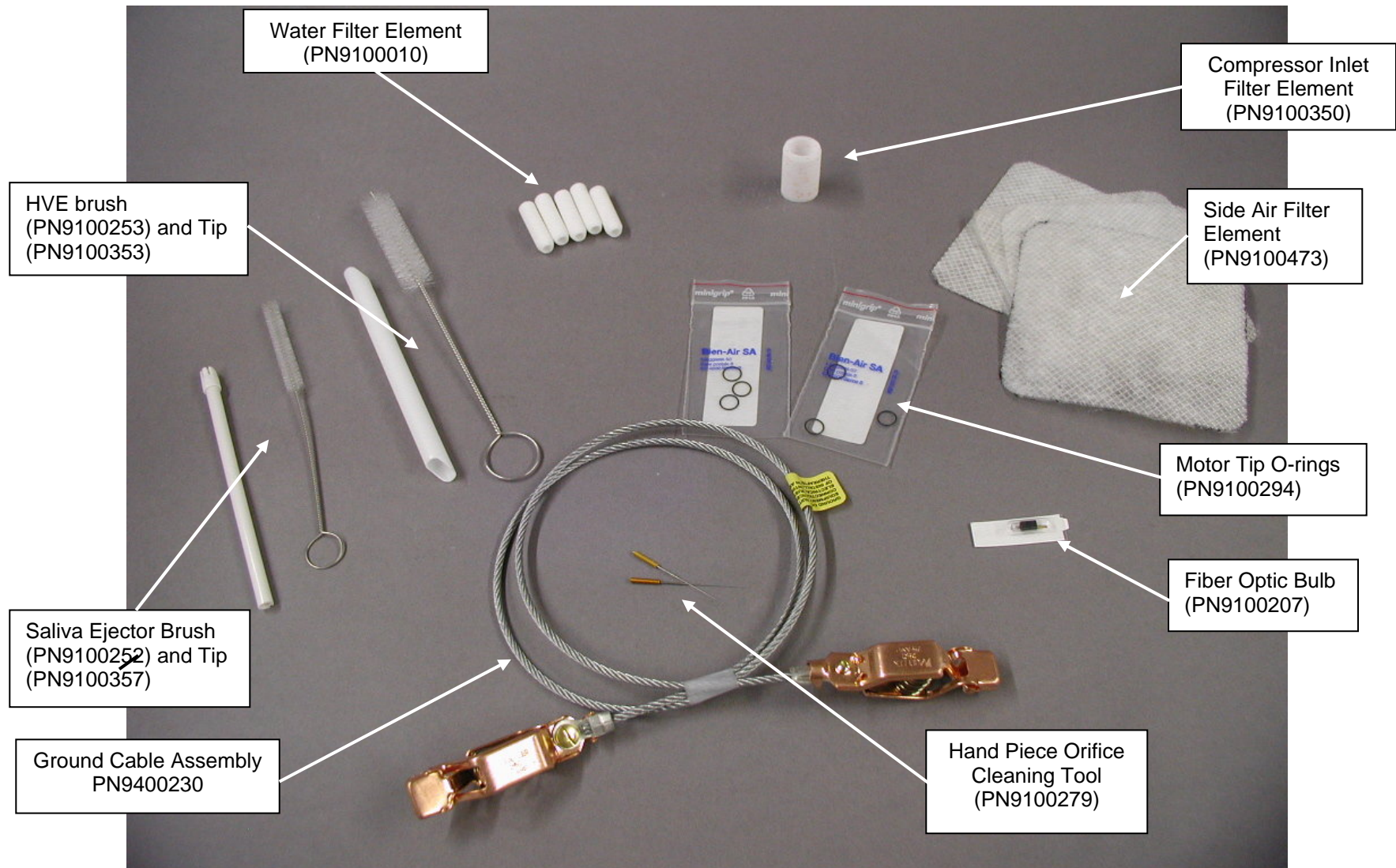

Figure 1.3-2

PortaBELL™III DeFTOS III Accessory Support Components



© 2006 Bell Dental Products, LLC. All rights reserved. No portion may be copied or reproduced without express written permission from Bell Dental Products, LLC.

Figure 1.4-1

Air Supply Subsystem Block Diagram

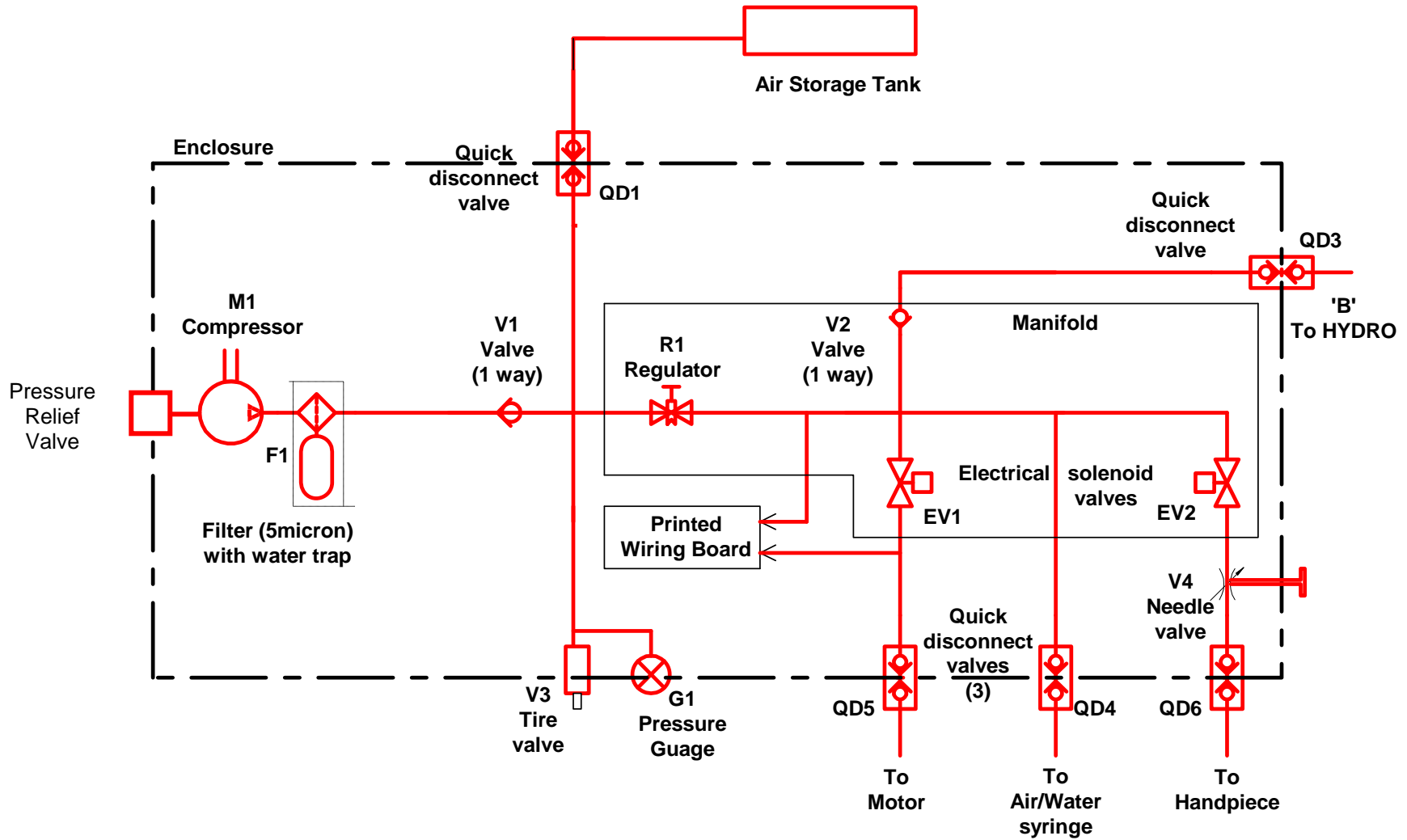

Figure 1.4-2

Water Supply Subsystem Block Diagram

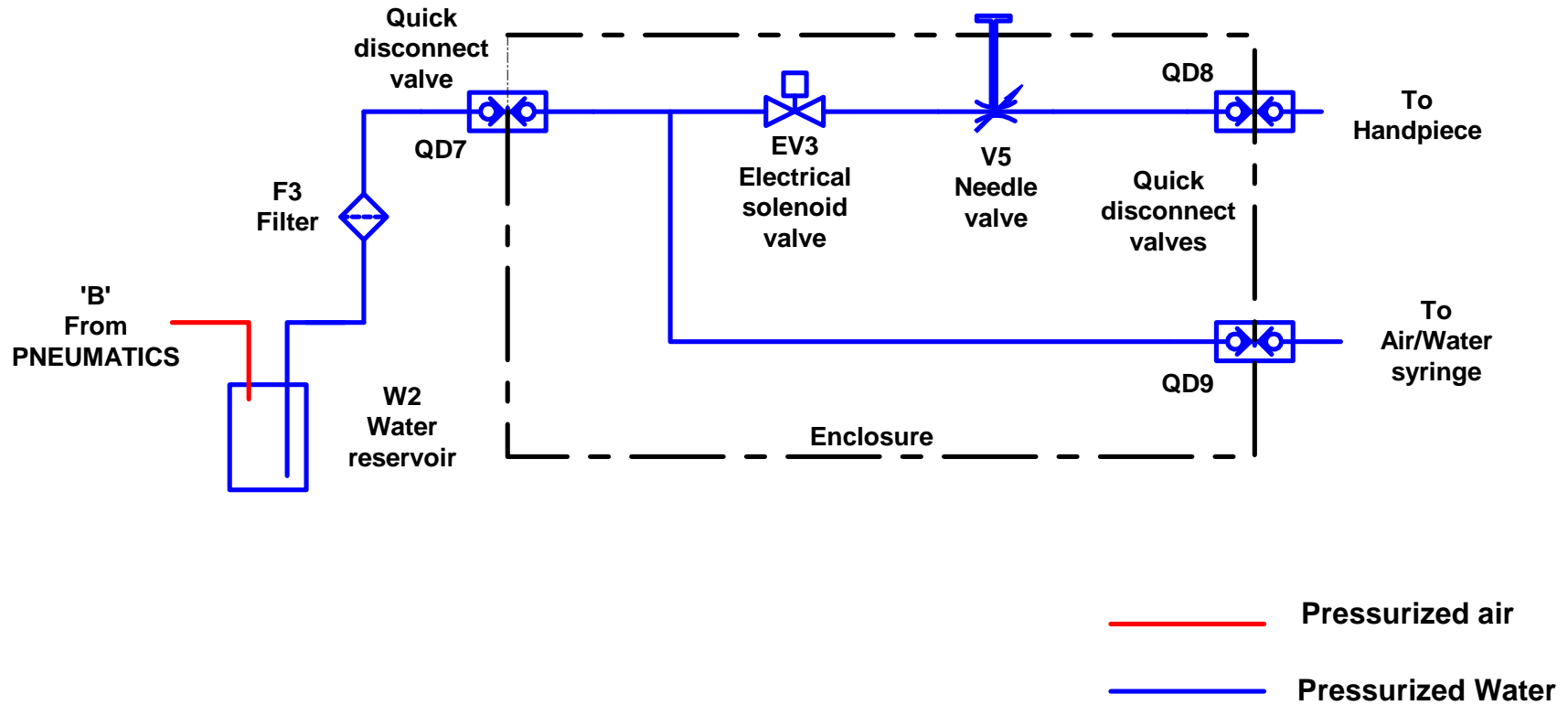

Figure 1.4-3

Vacuum Supply Subsystem Block Diagram

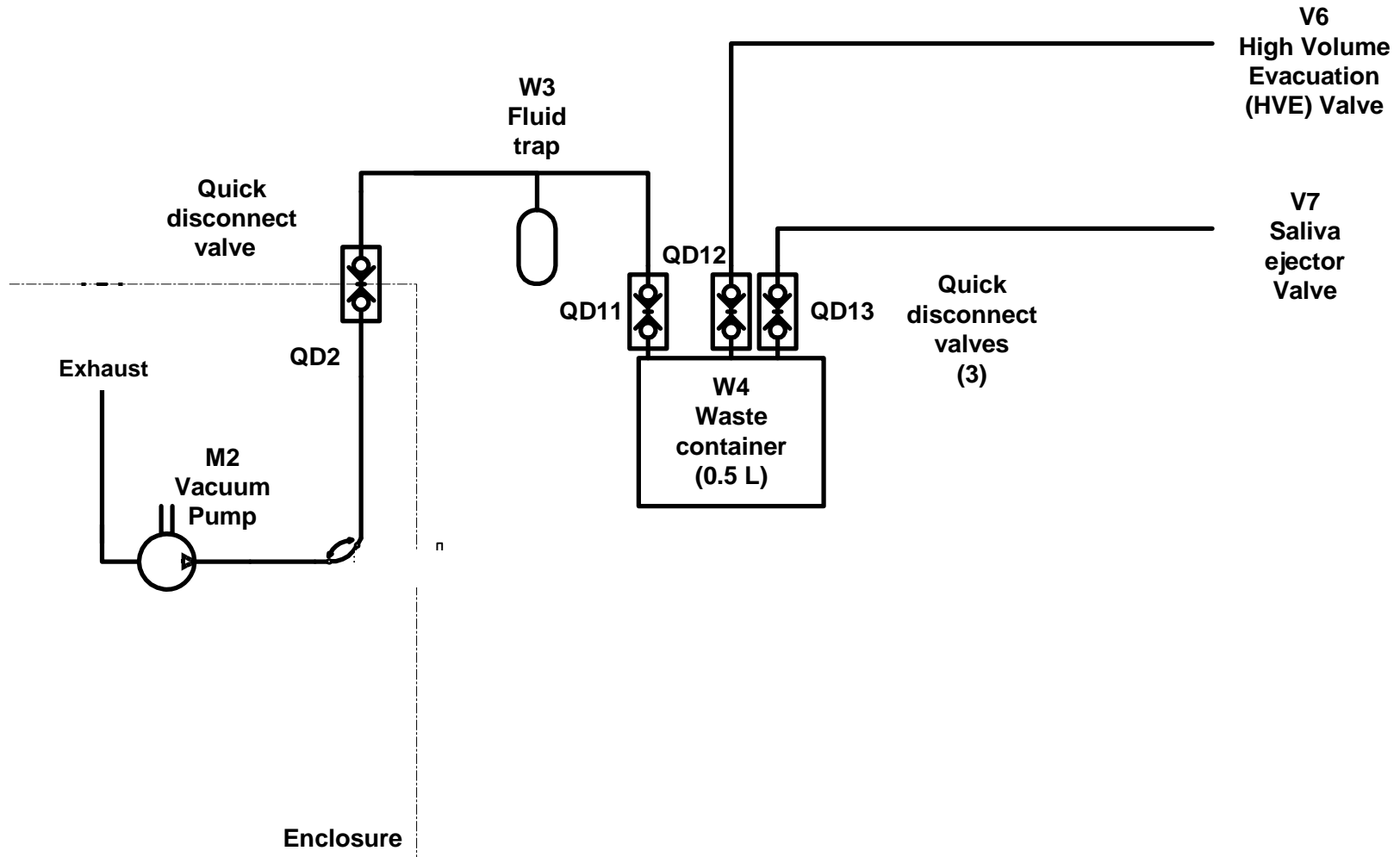
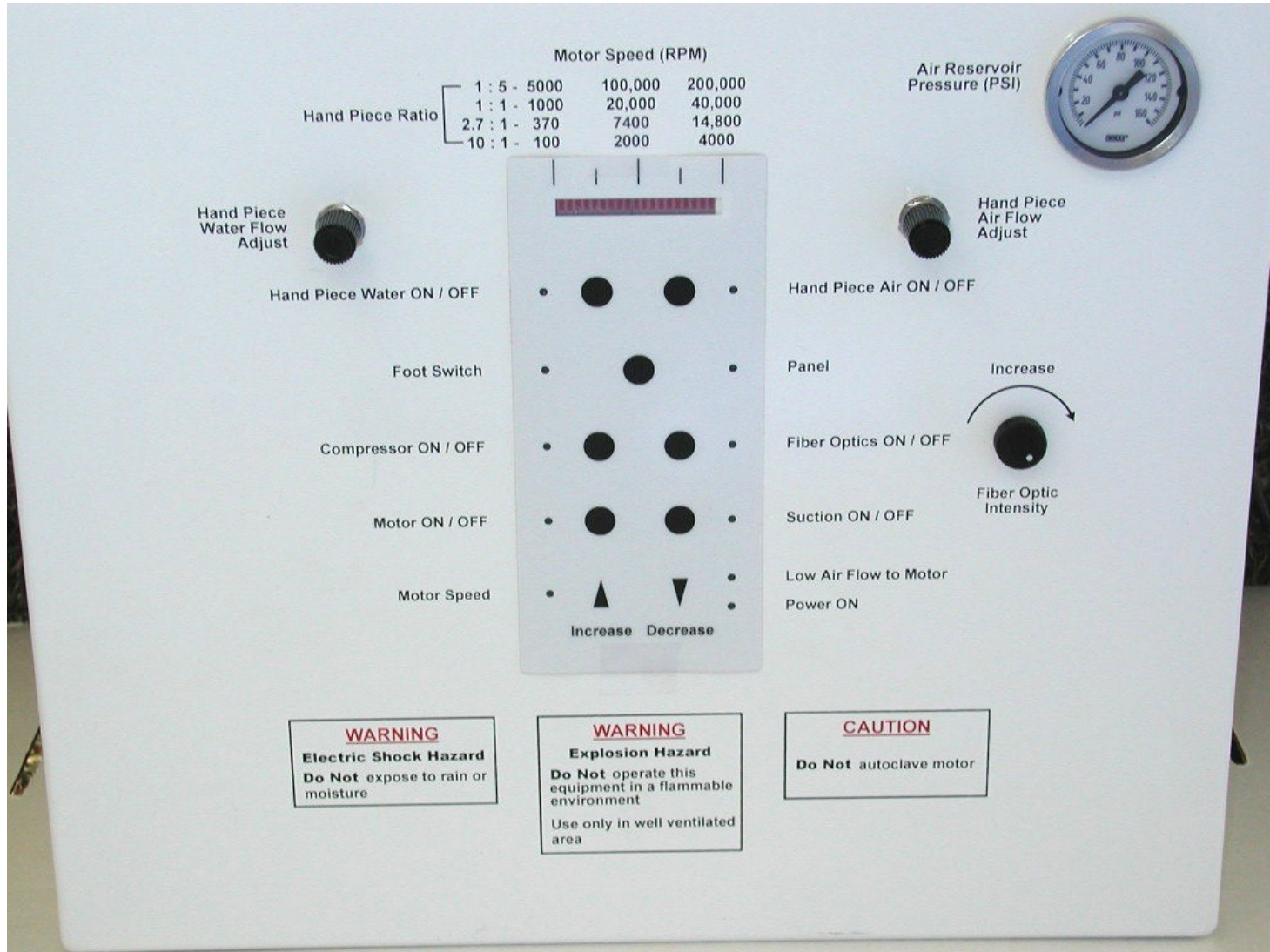

Figure 1.4-4
Control Panel



© 2006 Bell Dental Products, LLC. All rights reserved. No portion may be copied or reproduced without express written permission from Bell Dental Products, LLC.

Figure 1.4-5

Back Panel



© 2006 Bell Dental Products, LLC. All rights reserved. No portion may be copied or reproduced without express written permission from Bell Dental Products, LLC.

1.4.1 Electric Power Subsystem

The electric power subsystem provides power to the unit. It is composed of the power cord, power cord connector, main power switch, duplex outlet, circuit breakers, RF Filter, compressor, vacuum pump, and duplex outlet relays, power supply, voltage control circuit board, voltage control relays, 220VAC to 110VAC step down transformer, and associated connections and wiring, refer to Figures 1.4-6 and 1.4-7.

The system is designed to be capable of operation on any power from 100VAC to 240VAC, 50 or 60 Hz. The voltage control circuit board senses the input voltage and configures the power system according to the power it is connected to. The voltage control circuit board senses the voltage and then configures the voltage control relays to the proper configuration.

The duplex outlet allows for the connection and operation of additional accessories. It is switched through the power switch and has its own circuit breakers. It is connected to a step-down transformer for when the unit is connected to 200VAC or more.

NOTE

The duplex outlet will **ALWAYS** be approximately 110VAC. The voltage will vary depending on the mains voltage. The frequency will be **THE SAME AS** the mains power.

WARNING - Electrical and Fire hazard

If the frequency of the load and the duplex outlet are not the same it may cause heating of the load and step down transformer and may cause an electrical short or fire.

NOTE

The duplex outlet is rated for 100watts

The entire unit is protected by a 10-amp circuit breaker incorporated into the mains power circuit and the line and return of the duplex outlet are protected by 2A circuit breakers.

Figure 1.4-6
Electric Power Block Diagram

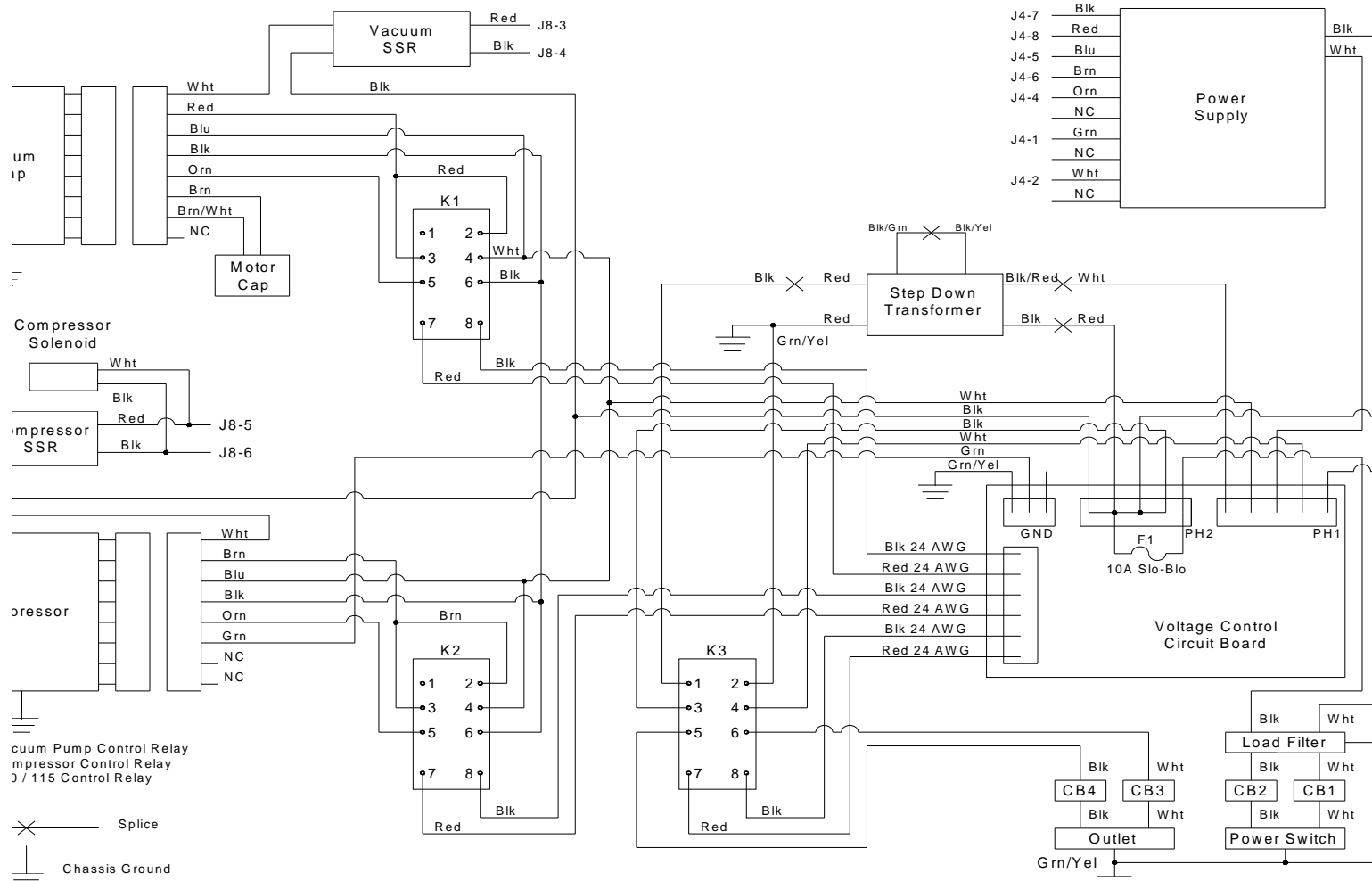

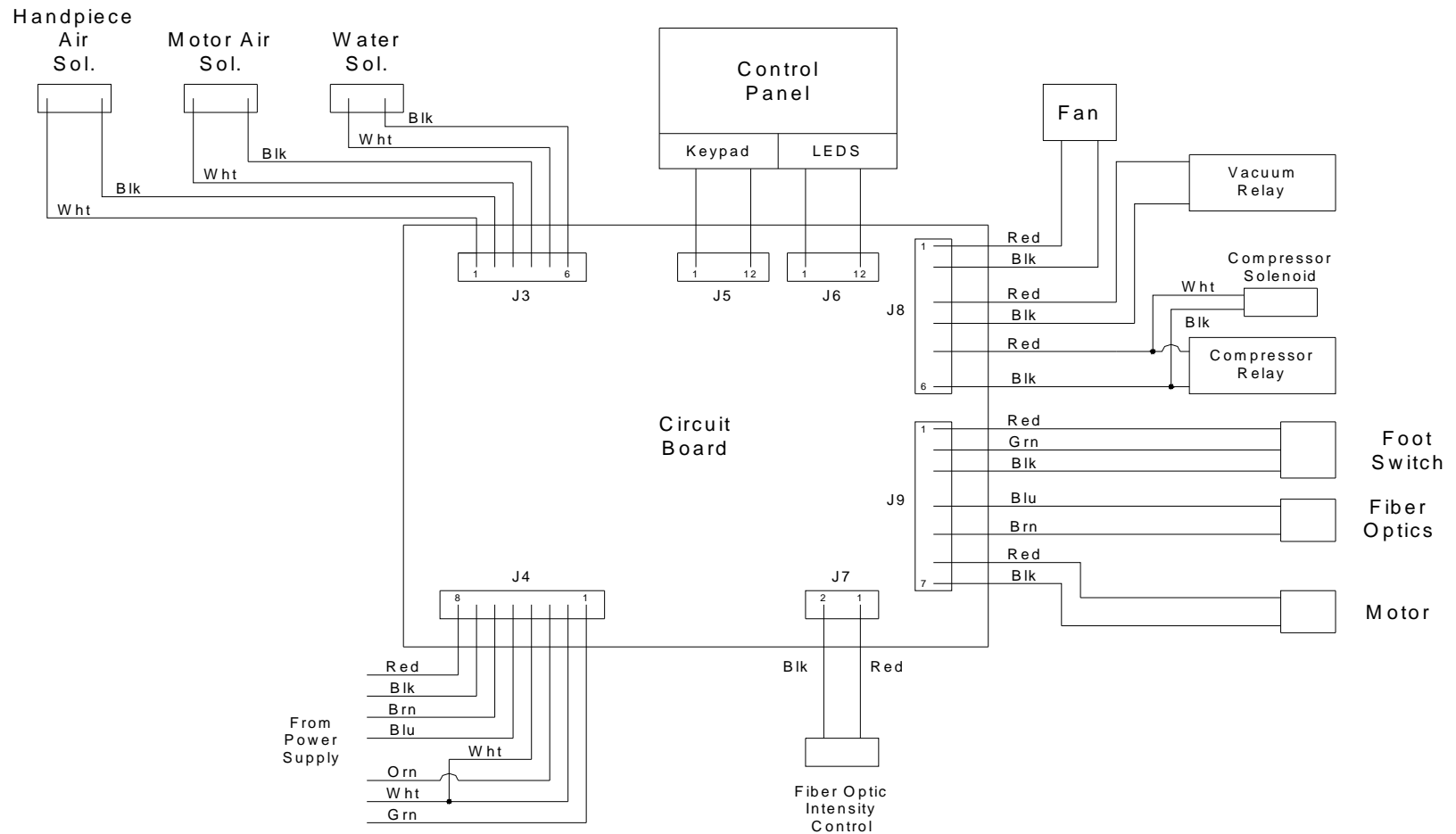

Figure 1.4-7
Circuit Board Block Diagram

Electric power is provided to the compressor and vacuum pump through a logic activated relay. When the compressor ON or Vacuum ON control buttons on the control panel are activated the associated relay closes and power is provided to the compressor or vacuum pump. The compressor also has a pressure limit shut-off. When the pressure in the air storage tank reaches approximately 60 PSI the control circuit board deactivates the relay turning the compressor OFF. This also deactivates the normally open bleed solenoid valve bleeding the air from the compressor cylinder.

NOTE

The compressor will not restart with pressure in the compressor cylinder or vacuum in the vacuum line.

1.4.2 Electronic Control Subsystem

The electronic control subsystem powers and controls operation of the low voltage components, hand piece motor, fiber optics, compressor, vacuum pump, and duplex outlet relays, cooling fan, and solenoid valves, refer to Figure 1.4-7. It is composed of the control circuit board and control panel.

The control circuit board takes 36 VDC, 12 VDC, and 5 VDC from the power supply and provides 0 to 30 VDC to the motor, 12 VDC to the solenoid valves, compressor, vacuum pump, and duplex outlet relays, and fan, and 5 VDC to the fiber optics. Control circuitry is incorporated into the circuit board to apply power to the solenoid valves and fiber optics only when they have been turned ON at the control panel and the motor is operating and to keep the fiber optics ON for approximately 20 seconds after the motor is turned OFF.

Motor controls include ON/OFF, Panel/Foot Switch, speed, and low cooling airflow. The Panel/Foot Switch switch is included to allow motor control in the event the foot switch fails. When in Panel mode motor speed can be controlled using the motor speed control buttons on the control panel.

The low cooling airflow sensor on the control circuit board senses when there is low cooling airflow to the motor, stops the motor and illuminates the red low cooling airflow LED on the control panel. The operator can override the control and restart the motor by pressing the motor speed increase button on the control panel once.

CAUTION

The motor requires cooling air. Motor damage may result if the motor is operated for extended periods without cooling airflow.

1.4.3 Air Supply Subsystem

The air supply subsystem provides compressed air to the unit for motor cooling air, chip air for the hand piece, and pressurization for the water supply subsystem. It is composed of an oilless air compressor, check valve, in-line water trap/filter, distribution manifold, pressure regulator, solenoid valves, flow control valve, air storage tank, external air valve, air/water syringe (this has been included in both the air and water subsystems), pressure gauge, pressure sensor, compressor bleed solenoid valve, and associated plumbing and fittings, refer to Figure 1.4-1

The air storage tank can be pressurized by either the internal compressor or an external compressed air source. The pressure gauge is used to monitor the pressure in the air storage tank.

Compressed air flows from the compressor through the water trap/filter and check valve to the air storage tank and pressure regulator. The regulator controls the air pressure to the motor, water reservoir, air/water syringe, and hand piece and is set at the factory to approximately 60 PSI. Airflow to the motor is controlled by a solenoid valve on the manifold. The solenoid valve opens whenever the motor is turned on. This is an automatic function. The motor airflow splits, going to the low cooling airflow sensor on the circuit board and to the motor through the motor cooling airflow control needle valve. The hand piece airflow is controlled by a solenoid valve on the manifold. The air flows through the solenoid valve and then through a flow control needle valve to the hand piece. When the air control on the control panel is ON the solenoid valve is opened when the motor turns on, allowing air to flow to the hand piece. Air is provided directly to the air/water syringe with the syringe controlling the ON/OFF flow.

A pressure relief valve is incorporated into the compressor outlet. The valve relieves the pressure at about 70 PSI. This reduces the load on the compressor and the power draw.

There is also a compressor bleed solenoid valve connected to the outlet of the compressor. This is a normally OPEN valve that is closed by the control microprocessor on the main circuit board when compressed air is needed, that is the pressure is about 40 PSI or less. The valve opens when the compressor is turned OFF bleeding the air from the compressor outlet line. Note, the compressor WILL NOT restart with pressure in the outlet line.

1.4.4 Water Supply Subsystem

The water supply subsystem is an independent self-contained water system, which provides water to the air/water syringe and hand piece. It is composed of the water reservoir, filter, water solenoid valve, water flow control

© 2006 Bell Dental Products, LLC. All rights reserved. No portion may be copied or reproduced without express written permission from Bell Dental Products, LLC.

valve, back flow check valve, air/water syringe, and associated plumbing and fittings, refer to Figure 1.4-2.

Compressed air pressurizes the water reservoir, which forces water through the filter. The flow splits between the air/water syringe and hand piece. The hand piece flow goes through a solenoid valve and then through a flow control needle valve. When the hand piece water control on the control panel is ON the solenoid valve is opened when the motor turns on, allowing water to flow to the hand piece. Water is provided directly to the air/water syringe with the syringe controlling the ON/OFF flow.

1.4.5 Vacuum Supply Subsystem

The vacuum supply subsystem is an independent self-contained vacuum system, which provides vacuum for the HVE and saliva ejector. It is composed of an oilless vacuum pump, waste container, solids trap, vacuum water trap, HVE, saliva ejector, vacuum shut-off valve, and associated plumbing and fittings, refer to Figure 1.4-3.

The HVE and saliva ejector tubes are attached to the top of the waste container. When the vacuum control on the control panel is turned ON the vacuum pump is activated and evacuates the waste container, drawing the waste fluids through the HVE and saliva ejector tubes into the waste container. The solids trap is located in the waste container.

The vacuum shut-off valve is integrated into the vacuum connector on the waste container top. It is a float type valve. When the fluids get to a certain level in the waste container a float ball will shut the vacuum off.

NOTE

It is possible for the vacuum shut-off valve to activate prematurely and/or stick if it has not been cleaned completely. To restore flow if the valve activates prematurely you must release the vacuum on the valve. To release the vacuum just turn the vacuum pump OFF and open the HVE valve, this will allow the valve to OPEN.

NOTE

If the vacuum pump is left ON and there is no operation of the hand piece motor for approximately 12 minutes the controller will turn the vacuum pump OFF and blink the Suction ON LED. To restore normal operation press the Suction ON button on the Control Panel.

NOTE

In the event there is a sudden loss of suction with the HVE and saliva ejector check the fluid level in the waste container.

NOTE

The vacuum pump WILL NOT start with vacuum in the inlet line. In this situation the motor will make a humming sound when turned ON. To relieve the vacuum connect a vacuum tube or fitting to the vacuum connector on the back of the base unit, see page 29

NOTE

A thermal shut-off switch is integrated into the pump motor windings to shut the pump off if it gets too hot. To resume operation just let the pump cool down.

2.0 SET-UP

Follow the steps outlined below to set-up the PortaBELL™ DeFTOS:

- Release the case latches by turning them counterclockwise;
- Open the top;
- Remove accessories and the base unit from the container and place the base unit in the desired location;
- Level the base unit by adjusting the feet on the bottom of the base unit;



- Insert the support pole brackets into the mounting holes on the side of the base unit, make sure the bracket is mounted with the bigger hole on the top;



- Insert the support pole into the support pole bracket on the side of the base unit;

NOTE

There is a place for a support pole bracket on both sides of the base unit, allowing the unit to be set-up for either left or right hand operation



- Insert zero, one or two extension arms into the top of the support pole;

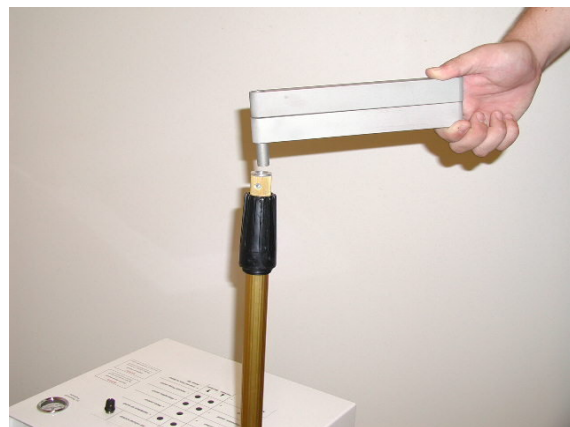

- Insert the instrument tray into the extension arm(s);

CAUTION

Do not put more than 10 pounds on the instrument tray



- Adjust the height of the instrument tray to the desired height by depressing the spring loaded button on the support pole and adjusting the height to the desired level;



- Attach the waste/water container holder bracket to the support pole. Position the bracket between 2 holes at the desired location and tighten the wing nuts;



- Fill the water bottle with clean water;

- Insert the water bottle into the water bottle holder;



- Connect the water bottle air and water fittings to the base unit by firmly pushing them into the fittings on the base unit;



NOTE

The quick disconnect release tab on the fittings must be in the release position to insert the fitting. Press the release tab to set it in the release position.

Pressing the release tab



- Position the air storage tank close to the base unit;

- Connect the air storage tank air hose to the base unit and air storage tank;



- Check the motor end of the motor hose for the air hand piece adapter. If the adapter is attached remove the adapter. Store the adapter in the hand piece pouch;

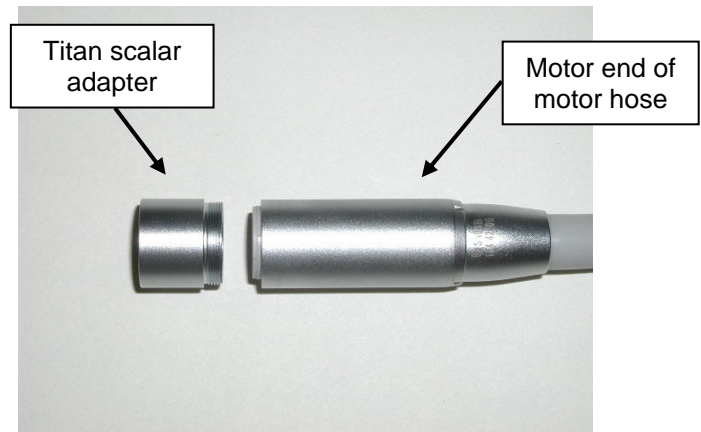

- Connect the motor hose to the base unit and place the motor end in the holder on the instrument tray;

CAUTION

Insert the fitting into the receptacle, slide the connector collar into the receptacle and gently rotate it until it goes into the receptacle, then gently rotate it 1/8 turn clockwise until it clicks to latch DO NOT over tighten.

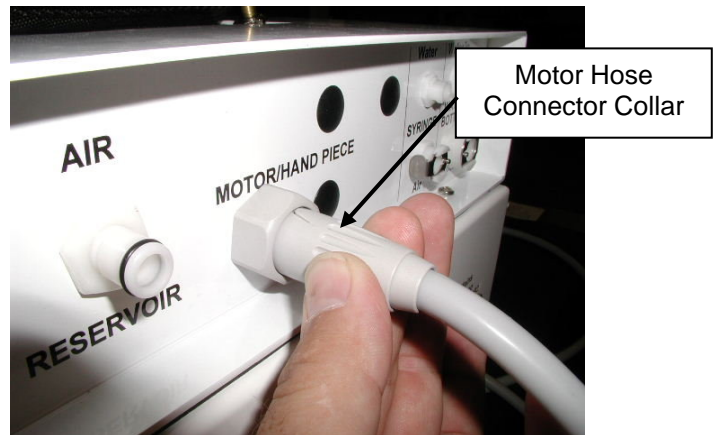

- Connect the motor to the motor hose;

CAUTION

Care must be taken to connect the motor to the motor hose. The thread is very fine and can easily be stripped.

- Attach the desired hand piece to the motor, make sure the fiber optic button is aligned with the recess in the motor;

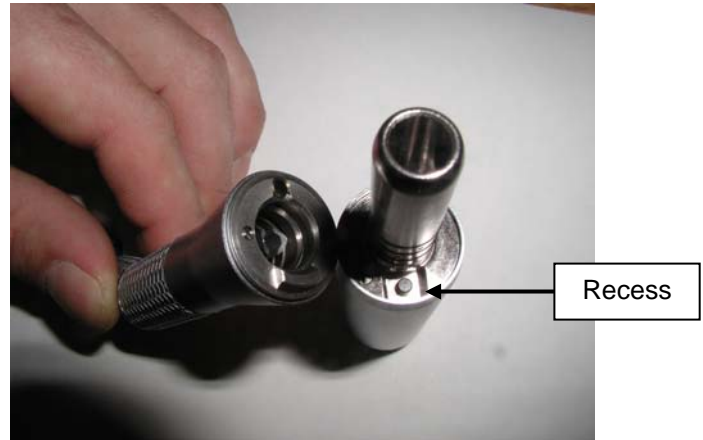

- Insert the waste container into the holder ring on the bracket;



- Connect the vacuum hose to the waste container by inserting the water trap fitting into the white fitting on the top of the waste container;



- Connect the vacuum hose to the black vacuum connector on the base unit;



- Connect the saliva ejector tube to the waster container and place it in the holder on the instrument tray;



- Connect the HVE tube to the waster container and place it in the holder on the instrument tray;



- Connect the air/water syringe to the base unit and place it in the holder on the instrument tray;



- Confirm that the power switch is in the OFF position. Connect the power cord to the connector;

- Connect the ground cable to the ground lug if necessary.



THE UNIT IS SET-UP AND READY FOR USE

3.0 OPERATION

Follow the steps outlined below to operate the PortaBELL™ III DeFTOS II. These instructions assume that the system has been set-up as described in Section 2.0 above:

- Turn the Power Switch to the “ON” (“1”) position, all of the LEDs on the control panel should light except the Panel LED. Press any control button to enable the system;
- Set the compressor to the “ON” position. Listen for the compressor operation, the compressor should start immediately, and stop when the air storage tank pressure reaches approximately 60 PSI;

NOTE

The system is equipped with a bleed valve to bleed pressure from the compressor head, the compressor will NOT restart with a pressure head. The bleed valve will make a hissing noise when the compressor turns OFF;

- Check the pressure gauge when the compressor stops;
- Set the Panel/Foot Switch control to the desired position;
- Set the fiber optic control to the desired position;
- Set the hand piece air to the desired position;
- Set the hand piece water to the desired position;

- Turn on the motor and adjust the motor speed to the desired speed using either the foot switch or control panel speed controls;
- Adjust the hand piece air and water flow to the desired flow using the adjustment controls on the control panel and begin the dental procedure;

NOTE

Listen for cooling airflow to the motor when the motor is started.

NOTE

The system includes a low cooling airflow to motor indicator. When low cooling airflow to the motor occurs the motor is disabled and a red indicator LED on the control panel is illuminated.

CAUTION

Operating the motor with low cooling air may cause motor damage.

- To restart the motor in the event low cooling airflow occurs, press the motor speed increase button once. The motor will be enabled and operate but there is still low cooling airflow to the motor;

NOTE

The fiber optic light is programmed to remain ON for approximately 20 seconds after the motor stops. It will turn ON again when the motor starts or the fiber optic panel control is cycled.

NOTE

The waste container is equipped with an automatic mechanical shut-off valve to shut-off vacuum when the waste container is full. If suction is lost, empty the waste container.

CAUTION

There may be fluids still in the lines and fittings when the vacuum shut-off valve has shut-off the vacuum. Use caution in removing the waste container top as these fluids may leak out.

NOTE

It is possible for the vacuum shut-off valve in the waste container to activate prematurely and/or stick if it has not been cleaned completely. To restore flow if the valve activates prematurely you must release the vacuum on the valve. To release the vacuum just turn the vacuum pump OFF and open the HVE valve, this will allow the valve to OPEN.

NOTE

Turn the vacuum pump OFF when not needed.

If the vacuum pump is left ON and there is no operation of the hand piece motor for approximately 12 minutes the controller will turn the vacuum pump OFF and blink the Vacuum Pump ON and Compressor ON LEDs. To restore normal operation press any button on the Control Panel.

4.0 PACKING THE UNIT FOR SHIPPING AND STORAGE

The unit is designed for storage at temperatures between -40°C and 60°C (-40°F to 140°F).

No periodic inspections are required during storage.

After storage a complete functional test should be performed in accordance with the Acceptance Test Record, refer to Appendix F. The most important considerations are air and water leaks. When the unit passes the acceptance test follow normal set-up and check out procedures to confirm operational readiness.

NOTE

Remove all water from the water lines before shipping or storing the unit.

Follow the steps outlined below to pack the system for shipping or storage:

- Turn the power switch to the OFF position;
- Disconnect the HVE, saliva ejector, and vacuum hoses from the waste container;
- Remove the waste container from the holder;

CAUTION

When removing the top of the waste container as there may be fluids in the fittings that may leak.

- Take the top off of the waste container and lift out the solids trap. Dispose of the solids in accordance with standard procedures;
- Empty the waste container in accordance with standard procedures;

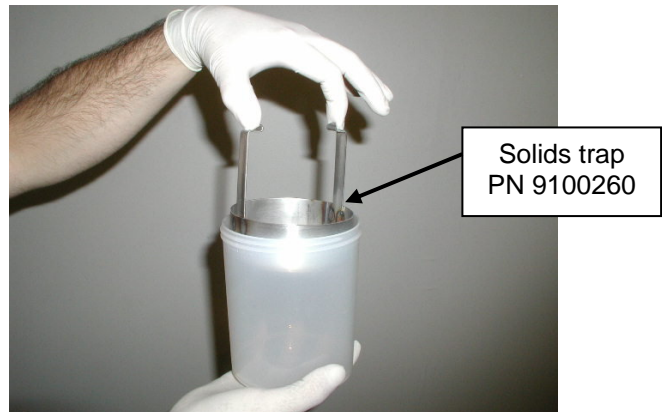

- Reinstall the waste container and connect the vacuum, HVE, and saliva ejector hoses, turn the power and the suction ON;

- Flush the HVE, saliva ejector, and their tubing by sucking at least 500 ml of liquid oral evacuation cleaner through the hoses;

NOTE

All water must be removed from the water lines before packing the unit.

- Empty the water bottle;

- Open the water volume control on the control panel completely open (all the way counter clockwise);

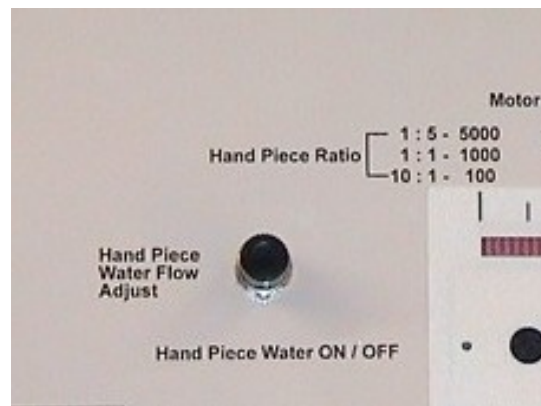

- Reconnect the empty water bottle and operate the motor to blow air through the hand piece water line for at least 5 minutes;

- Operate the water portion of the air water syringe for at least 5 minutes to remove water from the line;

- Empty the air storage tank by the following steps:

- Release the pressure in the air storage tank by pulling on the release ring of the pressure release valve attached to the end of the air tank, twist the air tank to expel all of the air;



- Expel all of the air from the air tank by holding the relief valve open and twisting the air tank, this is important to make enough room for the hose pouch;



- Push the release valve closed when all of the air has been expelled from the air storage tank;

- Pack the unit in the shipping and storage container by the following steps:

- Open the shipping and storage container;

- Disconnect all cords and tubes from the base unit;

- Remove the instrument tray, extension arms, and support pole from the base unit;

- Remove the water reservoir and waste container from the base unit;

- Place base unit in the shipping and storage container with the front of the unit facing the front of the shipping and storage container;



Storage Pouch 1

- Pack the motor hose, water reservoir manifold and hose, air/water syringe, air storage tank hose, and ground cable into Storage Pouch 1;

- The inside of the pouch is equipped with pockets to hold the motor and hand pieces;



Storage Pouch 2

- Pack the power cord, HVE, saliva ejector, vacuum hoses, and remaining motors and/or hand pieces into Storage Pouch 2;

- The inside of the pouch is equipped with pockets to hold the motor and hand pieces;



Storage pouch 3

- Pack the Manual and additional documentation into Storage Pouch 3;

Storage Pouch 4

- Pack the spare parts and motor and hand piece manuals into Storage Pouch 4;

- Place the extension arms, support pole brackets, water bottle, foot switch, waste container Bio Lube™, E-formula, or Lubrifluid®, and Bio Lube™ Handpiece Cleaner, or Spraynet, in the accessory foam tray;



- Place the instrument tray in the front of the container with the tray facing out;



- Place the collapsible air tank on the bottom of the container between the tray and the base unit. Make sure it is laying flat across the bottom with the connector end on the bottom;



View looking down into the container showing the proper placement of the instrument tray and collapsible air tank.



- Place Storage Pouch 2 containing the vacuum hoses between the instrument tray and the base unit;



- Place Storage Pouch 3 along the left side of the base unit and Storage Pouch 4 along the right side of the base unit;

- Place the foam insert on top of the base unit with the waste container to the back, make sure the needle valve knobs line up with the recess holes in the foam insert and the front of the foam insert is placed below the pin of the instrument tray;



- Place Storage Pouch 1 and the support pole on top of the foam insert, make sure the support pole is collapsed fully;



- Close and latch the top of the container.

The unit is ready for shipment or storage

© 2006 Bell Dental Products, LLC. All rights reserved. No portion may be copied or reproduced without express written permission from Bell Dental Products, LLC.

5.0 MAINTENANCE

The PortaBELL™ II, DeFTOS II, requires limited maintenance actions: sterilization and disinfection, cleaning, draining of water traps, replacement of filter elements, and replacing the fiber optic lamp.

5.1 Periodic Maintenance

This section presents the few periodic maintenance actions to support the DeFTOS.

At the end of each day the following should be done:

- Check compressor water trap, drain if necessary (see 5.4.1)
- Check vacuum water trap, drain if necessary (see 5.4.2)
- Check inlet air filters for blockage, clean with compressed air if necessary (5.5.5)
- Check the water line filter, replace if blocked or discolored (see 5.5.1)
- Drain any water from the air reservoir (see page 33)
- Wipe the housing and associated accessories with a standard disinfecting solution
- Empty the waste container
- Flush the HVE and saliva ejector tubes with at least 500 ml of liquid oral evacuation cleaner

NOTE

The capacity of the waste container is 500ml. The waste container will have to be emptied between cleaning the HVE and saliva ejector tubes

- Empty the water reservoir
- Drain all of the water from the syringe and hand piece water lines
- Check the air inlet filters on the side of the base unit, with the base unit closed and the cooling fan ON you should be able to feel air flow from

the air filter on the right side of the base unit, the one opposite the fan. If not, then clean or replace the filter elements

5.2 Sterilization and Disinfection

Asepsis of the system is of utmost importance. Between patients all of the major components composing the PortaBELL™III must be disinfected by either steam autoclave or wipe down with disinfectant solution. Table 5.2-1 presents a summary of sterilization/disinfection methods for each of the major components.

5.3 Cleaning

Unplug all electrical connections before cleaning the PortaBELL™ DeFTOS.

5.3.1 Motor

Please refer to Appendices D and E for cleaning information and instructions.

The motor outer sheath can be removed from the motor and autoclaved.

The motor and cord can be disinfected using standard disinfecting solutions.

NOTE

DO NOT autoclave the motor. Autoclaving the motor will damage the motor and make it inoperable.

Table 5-2-1

Summary of Sterilization/Disinfection Methods for PortaBELL™ Components

COMPONENT	STERILIZE/DISINFECTION METHOD	SOURCE
Hand piece	Steam Autoclave (manufacturers instruction, see Appendix A)	Bien Air
Motor sheath	Steam Autoclave (manufacturers instruction, see Appendix A)	Bien Air
Motor cord	Wipe w/disinfecting solution	Bien Air
Air/water syringe tip	Steam Autoclave	DCI
Air/water syringe body	Disinfecting solution	DCI
Air/water syringe water tubing	Disinfecting solution	DCI
Saliva ejector tip	Disinfecting solution	DCI
Saliva ejector body	Steam Autoclave DO NOT EXPOSE TO CHLORINATED SOLUTIONS	DCI
Saliva ejector tubing	Disinfecting solution	DCI
HVE tip	Disinfecting solution	DCI
HVE body	Steam Autoclave DO NOT EXPOSE TO CHLORINATED SOLUTIONS	DCI
HVE tubing	Disinfecting solution	DCI
Instrument tray	Wipe w/disinfecting solution	DCI
Base unit surfaces	Wipe w/disinfecting solution	Cardinal Powder Coat
Waste container	Steam autoclave	Consolidated Plastics
Waste container top	Disinfecting solution	DCI
Vacuum water trap	Disinfecting solution	PIAB
Vacuum fittings polypropylene,	Disinfecting solution	Colder Products
Water bottle, polypropylene	Disinfecting solution	DCI
Water bottle manifold	Disinfecting solution	DCI
Water fittings, polypropylene	Disinfecting solution	Colder Products
Water tubing/polypropylene	Disinfecting solution	Advanced Air Products

5.3.2 Hand Pieces

Please refer to Appendices D and E for cleaning information and instructions.

- Cleaning and lubricating the hand pieces.

NOTE

The hand pieces **MUST** be cleaned, lubricated, and sterilized between each patient.

- The hand pieces can accumulate fluids and tissue in the head. Take the hand piece and submerge the head in water. Using the motor, operate the hand piece for 30 seconds to 1 minute. This will “flush” the fluids and tissue from the hand piece. Repeat until the water is clear after operating the hand piece for 30 seconds to 1 minute. The hand piece is now ready for cleaning and sterilization;

Cleaning the hand pieces:

- Insert the hand piece onto the nozzle of the Bio Lube™ Handpiece Cleaner (PN 9400453), or Spraynet (PN9400081) canister and press the spray button for 1 second. Do this after each patient.
- Reattach the hand piece to the motor and run the hand piece for 20 to 25 seconds while holding the hand piece head toward the ground. This will force excess cleaner from the hand piece.



The hand piece is cleaned;

- Lubricating the hand piece:
- Insert the hand piece onto the nozzle of the Bio Lube™, E-formula lubricant (PN 9400452) or Lubrifiud® (PN 9400082) canister and press the spray button for 1 second, this must be done before autoclaving;
- Reattach the hand piece to the motor and run the hand piece for 20 to 25 seconds while holding the hand piece head toward the ground. This will expel any excess lubricant from the hand piece;
- The hand piece is lubricated and ready for sterilization;
- Sterilize the hand pieces:

Remove the hand piece from the motor and autoclave. Allow the autoclave to complete the drying cycle. If bagging the hand piece, DO NOT seal.

**DO NOT USE CHEMICLAVE TYPE
STERILIZATION**

- The hand pieces can be steam autoclaved
- Unclogging the water orifice

In the event the hand piece water orifice becomes clogged use the cleaning tool to unclog it. Gently insert the tool into the orifice. Move it around to loosen the blockage. Insert the tool as far as possible.



5.3.3 Waste container and waste container top

The waste container can be steam autoclaved. The top of the waste container can be cleaned using standard disinfecting solutions. Refer to Appendix A for acceptable disinfectant solutions. After the waste has been properly disposed of, rinse the container and either steam autoclave it or disinfect it with an appropriate disinfectant. Refer to Appendix A for acceptable disinfectant solutions.

5.3.4 Vacuum Hoses

All of the vacuum hoses can be disinfected using standard disinfecting solutions.

**DO NOT
Use chlorinated solutions.**

5.3.5 Vacuum Water Trap

The vacuum water trap can be disinfected using standard disinfecting solutions.

5.3.6 Water Reservoir and Water Lines

The water reservoir and lines can be disinfected using standard disinfecting solutions.

5.3.7 Base Unit and Control Panel

The base unit and control panel are coated with materials that can be disinfected using standard disinfecting solutions.

5.3.8 Instrument Tray

The instrument tray can be autoclaved or wiped with standard disinfecting solutions

5.4 Draining the Water Traps

There are 2 water traps incorporated into the PortaBELL.™ III DeFTOS II, one on the outlet of the compressor and one in the vacuum line from the waste container to the base unit. These may accumulate moisture and should be checked at the end of each day and drained if necessary.

5.4.1 Draining the Compressor Water Trap

- The compressor water trap can be drained by unscrewing the valve located at the bottom of the water trap bowl.

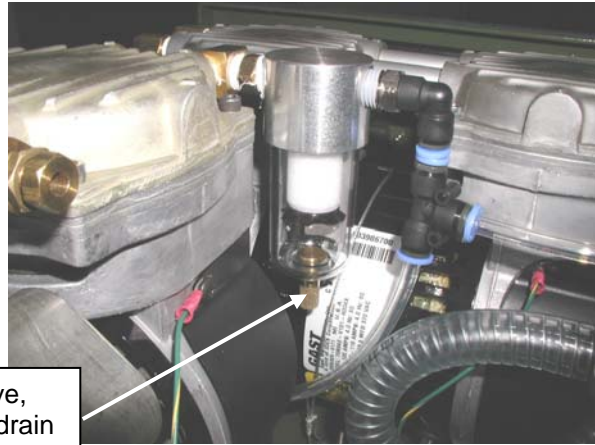

Drain valve, unscrew to drain

5.4.2 Draining the Vacuum Water Trap

- The vacuum water trap can be emptied by unscrewing the container from the top and emptying the container.

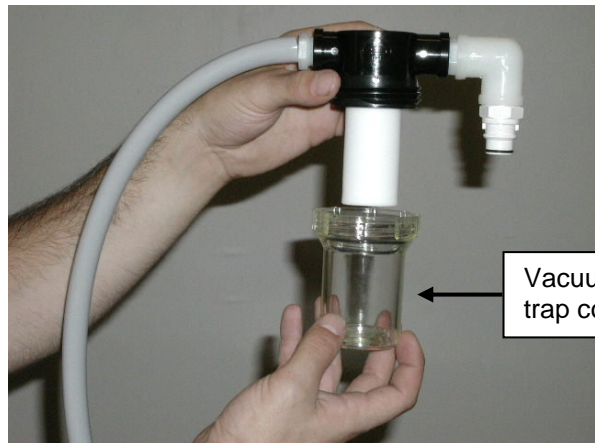

Vacuum water trap container

5.5 Cleaning or Replacing the Filter Elements

The PortaBELL™ DeFTOS incorporates 5 filter elements, the water line filter, the vacuum line water trap filter, the compressor water trap filter, the compressor inlet filter, and the cooling air filter.

5.5.1 Replacing the Water Line Filter Element (PN 9100010)

- The water line filter is attached to the outlet of the water bottle. Push in on the filter housing and twist the filter housing apart to access the filter element.



5.5.2 Replacing the Vacuum Line Water Trap Filter Element (PN 9100258)

- Replace the vacuum line water trap filter element by unscrewing the container and pulling the element out.

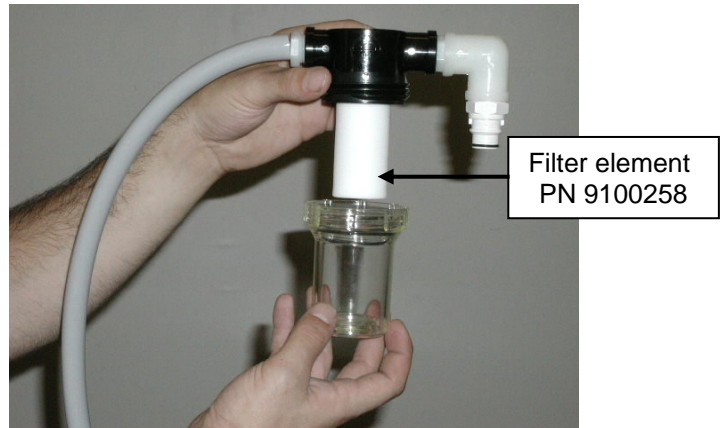

5.5.3 Replacing the Compressor Water Trap Filter Element (PN 9100352)

- Replace the compressor water trap filter by unscrewing the clear plastic bowl and unscrewing the filter element.



Water trap
filter
PN 9100352

5.5.4 Replacing the Compressor Inlet Filter Element (PN 9100350)

- Replace the compressor inlet filter by unscrewing the clear plastic bowl and unscrewing the filter element.

5.5.5 Cleaning the Cooling Air Filter Elements

(PN 9100295)

- Remove the filter covers and filter elements on either side of the base unit. Clean the filter elements with low pressure (20 to 30 PSI) compressed air. Replace the filter elements and covers.

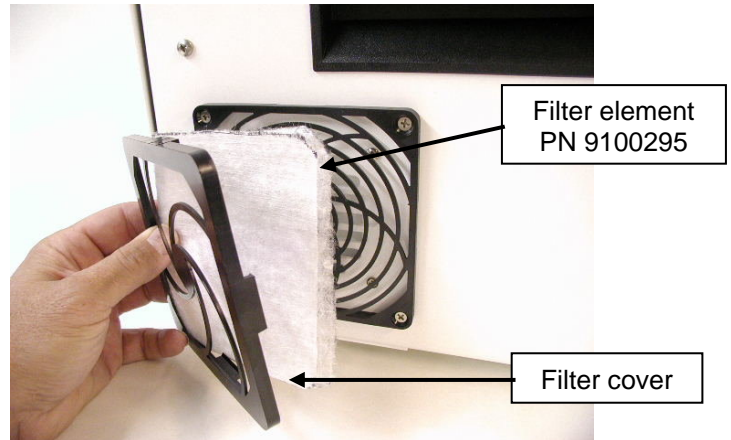

5.5.6 Replacing the Cooling Air Filter Elements

- Remove the filter covers on either side of the base unit and remove and replace the filter elements;

NOTE

Only install 1 filter element, more than one will reduce cooling air flow and may damage the motor

- Replace the filter cover

5.6 Replacing the Fiber Optic Lamp

- The fiber optic lamp is accessed by sliding the motor sheath off of the motor frame and lifting the lamp out of its socket.

CAUTION

The lamp may be very hot and may cause burns.

CAUTION

When handling the fiber optic lamp DO NOT touch the clear bulb part of the lamp with your skin as this will reduce the life of the lamp.

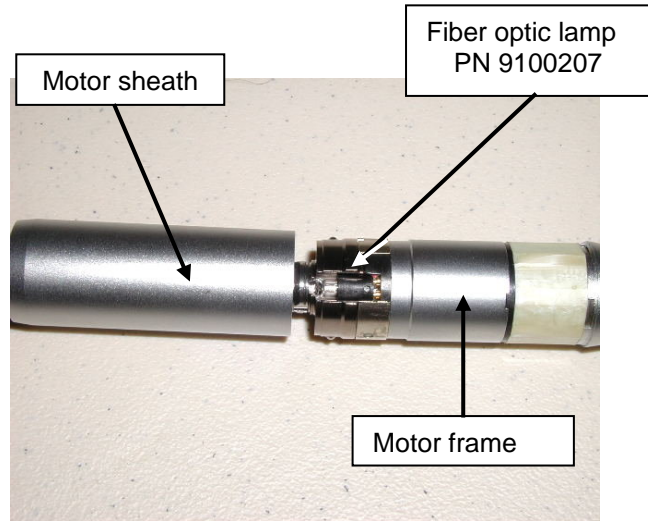

5.7 Checking the Suction System

The performance of the vacuum pump and integrity of the vacuum plumbing are important to provide optimal suction for the operator. To check the vacuum pump performance and vacuum plumbing integrity, do the following:

1. Get an 8 ounce container of water;
2. Connect the HVE, saliva ejector, and vacuum hoses to the waste container;
3. Confirm the top of the waste container is tight;
4. Confirm the HVE and saliva ejector valves are closed;
5. Start the vacuum pump using the control panel;
6. Open the HVE valve and immerse the end of the HVE into the container of water;
7. Time how long it takes to suck up the 8 ounces of water;
8. Turn off the suction after the water container has been emptied.

If the vacuum pump is working properly and the vacuum plumbing is sealed it should take no more than 10 seconds to suck all of the water from the container.

If it takes more than 10 seconds, check the vacuum system for leaks by doing the following:

1. Open the HVE valve;
2. Close the saliva ejector valve;
3. Lay the HVE tubing and valve down on a flat surface;
4. Seal the end of the HVE valve with a finger or other nonporous object;
5. Start the vacuum pump using the control panel, a vacuum will be developed. Let the vacuum pump run for 15 seconds and turn off the vacuum pump. The HVE valve should maintain a vacuum for at least 15 seconds. If the vacuum is lost sooner there is a vacuum leak in the vacuum plumbing. Check all connections and fittings, and make sure the waste container top is tight and seated properly. If no leaks are found the vacuum pump is probably the cause of the low suction.

5.8 Adjustments and Calibration

This section discusses various adjustments associated with the system. There are several adjustments that are set at the factory, including power supply output, circuit board output to the motor, motor maximum and minimum speeds, motor speed indication, regulated pressure, and compressor pressure relief. It is possible for these adjustments to change over time. If they do change it is possible they will need to be adjusted to assure proper system performance.

5.8.1 Voltage to the Hand Piece Motor

There are 2 potentiometers used to adjust the motor speed, one to adjust the maximum speed and one to adjust the minimum speed. These 2 potentiometers are located on the main circuit board, see Figure 5.8.1-1. These potentiometers are set at the factory. However, they may need adjustment periodically.

5.8.1.1 Motor Speed Adjustment

If the motor is ON and at zero speed then the motor speed should be zero. If the motor is turning slowly in this situation then the motor minimum speed adjustment potentiometer must be adjusted. Turn the motor minimum speed adjustment potentiometer counterclockwise until the motor stops. If the motor continues to turn then replace the main circuit board at the earliest convenient time. This situation DOES NOT affect the function of the hand piece, it can still be used normally.

With the motor ON and at maximum speed adjust the max speed potentiometer for maximum speed.

5.8.2 Motor Speed Indication

The motor speed indication, the LED bar, can be adjusted using a third potentiometer on the main circuit board, see Figure 5.8.1-1. With the motor ON and no motor speed no motor speed LEDs should be illuminated. With the motor ON and at full speed, and the fiber optics ON, all the motor speed LEDs should be illuminated.

5.8.2.1 Motor Speed Indicator LEDs Adjustment

The motor speed indicator LED adjustment is done using a potentiometer located on either the right side of the main circuit board or at the bottom right corner of the main circuit board. If, when the motor is at full speed, the last speed LED does not illuminate then adjust the motor speed Indicator LED potentiometer until the last LED is illuminated. If it is not possible to get the last LED illuminated then replace the main circuit board at the earliest convenient time. This situation DOES NOT affect the function of the hand piece, it can still be used normally.

Figure 5.8.1-1

Main Circuit Board Motor and Speed Display Adjustments

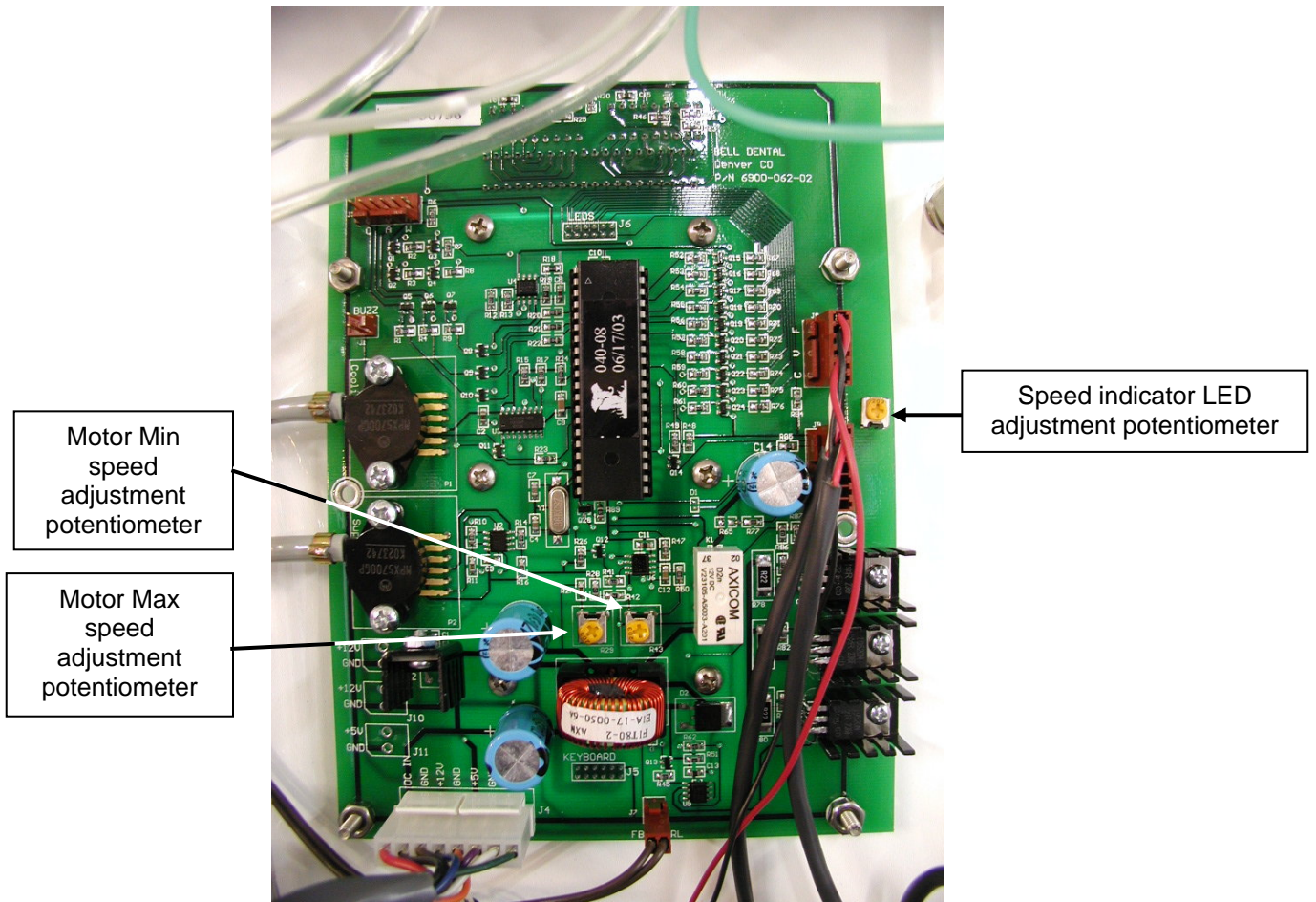

5.8.3 Regulated Pressure

There is a pressure regulator to regulate the pressure to the motor cooling, circuit board pressure sensors, hand piece, and water reservoir. The pressure must be set high enough to trigger the pressure switch on the circuit board that turns the compressor ON and OFF. Since there are slight variations in the specific switch pressure the regulator must be adjusted. If the regulated pressure is set below the switch pressure of the pressure switch on the main circuit board the pressure switch will never turn the compressor OFF. To adjust the regulated pressure turn the compressor ON and turn the adjustment screw on the regulator "in" until the compressor stops. Then turn the adjustment screw another $\frac{1}{4}$ turn, this will allow for some margin in the adjusted pressure. Bleed off the air pressure and check the operation.

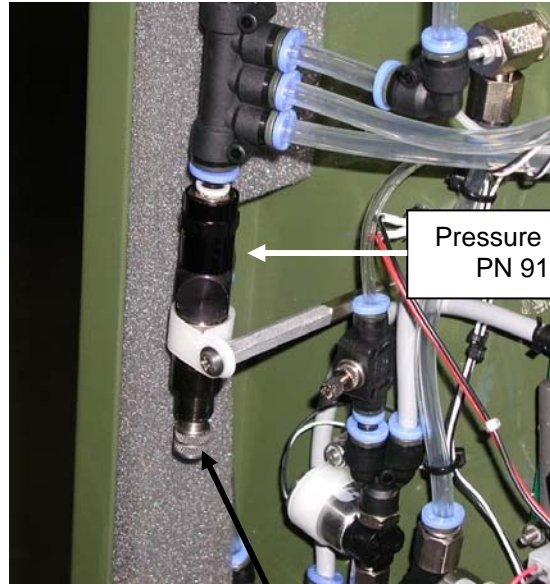

Pressure Regulator
PN 9100031

Regulated Pressure
Adjustment Knob

5.8.4 Compressor Pressure Relief

There is a pressure relief valve attached to the outlet of the compressor. This valve is set to relieve pressure at approximately 68 to 74 PSI. This reduces the load on the compressor when the vacuum switch is ON and the air pressure is above 60 PSI. If the pressure reading on the pressure gauge is greater than 74 PSI it is probably because the pressure relief valve is out of adjustment. Adjust accordingly and tighten the locking nut.

If the valve has gone out of adjustment on the low side it is possible that the compressor will not be able to reach 60 PSI and will not turn OFF. Adjust accordingly and tighten the locking nut.



5.8.5 Checking Cooling Air Flow to the Motor

The flow of cooling air to the motor is controlled by the solenoid valve identified in Figure 7.3.1. The flow should be at least 9 liters per minute at 50 PSI. To check the flow, insert the handpiece end of the motor into the flow meter, PN 9400229. Hold the flow meter vertically, turn on the motor and increase the speed until the cooling air flow solenoid opens.

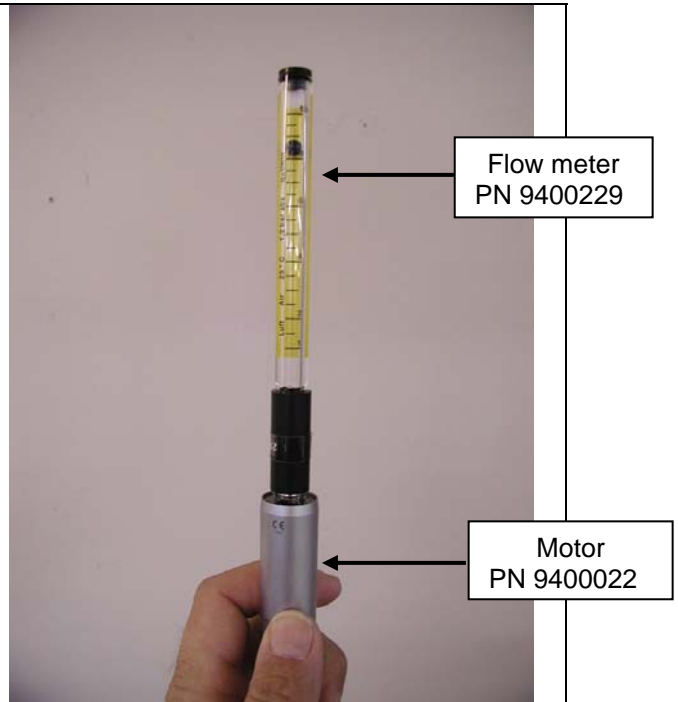

5.9 Removing and Replacing the Main Circuit Board

The main circuit board is mounted using 4 studs and nuts. The keypad circuit board is attached to the main circuit board by 2 multi-pin connectors. Since the keypad circuit board is connected to the keypad label it **MUST** be disconnected from the main circuit board.

To remove the main circuit board:

1. Disconnect all of the cables and disconnect the tubings connected to the Low Air Flow to Motor and Pressure Monitor pressure sensors at the push-in fittings connected to the solenoid valves, this will reduce the possibility of damaging the pressure sensors;
2. Gently lift the main circuit board out by placing your fingers under the top and bottom of the main circuit board and prying the circuit board out, this will unplug the main circuit board from the main circuit board;

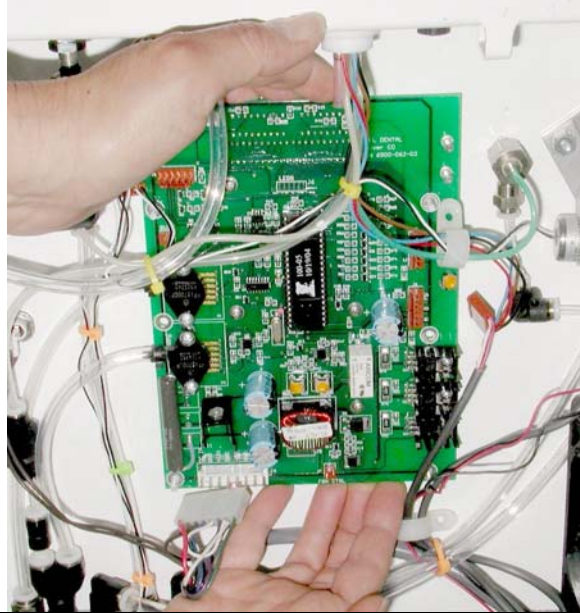

To replace the main circuit board:

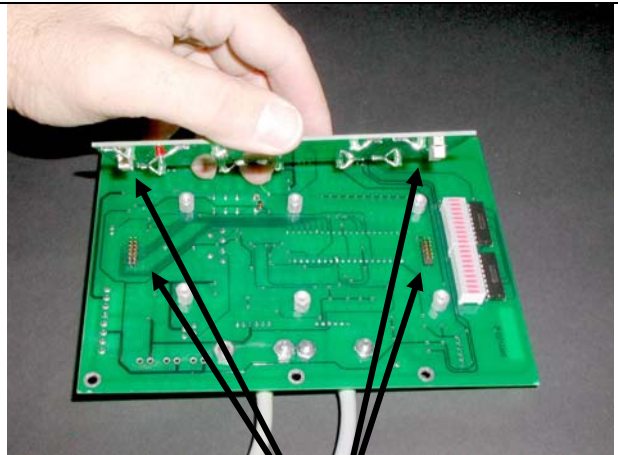

1. Align the main circuit board keypad circuit board connectors with the keypad circuit board connectors;
2. Gently push the main circuit board to the keypad circuit board connectors;
3. Reattach the connectors and pressure sensor tubings.



Main circuit board and keypad circuit board connectors

5.10 Removing Tubing From Push-in Fittings

The push-in fittings are used to facilitate removing and replacing tubing.

<p>To remove a tube from a push-in fitting:</p> <ol style="list-style-type: none">1. Depress the “collar” on the top of the fitting, this retracts a set of “fingers” in the fitting, releasing the tube;2. Pull the tube from the fitting. <p style="text-align: center;">NOTE</p> <p>Sometimes it might be necessary to push in on the tubing before removing it</p>	
<p>To connect tubing to a push-in fitting:</p> <p style="text-align: center;">IMPORTANT</p> <p>The end of the tubing MUST be cut at a right angle to seal properly in the fitting. If the tube is not cut properly it will leak.</p> <ol style="list-style-type: none">1. Cut the tubing;2. Insert the tubing into the push-in fitting. Make sure it is inserted completely.	

6.0 TROUBLESHOOTING

6.1 Motor and Hand Piece

PROBLEM	POSSIBLE CAUSES	RESPONSE OR CORRECTIVE ACTION
No power at hand piece	<ol style="list-style-type: none"> 1. Worn/broken brushes 2. Bad cord 3. Circuit breaker popped 4. Failed control circuit board 	<ol style="list-style-type: none"> 1. Replace motor, submit for service 2. Replace motor, submit for service 3. Replace motor, submit for service 4. Test circuit board, see paragraph 6.4
Intermittent operation	<ol style="list-style-type: none"> 1. Fouled brushes, carbon and/or dirt or oil build-up 2. Bad connection in power cord 3. Problem with controller 	<ol style="list-style-type: none"> 1. Replace motor, submit for service 2. Replace motor, submit for service 3. Test circuit board, see paragraph 6.4
Motor runs rough, noisy, and/or runs hot	<ol style="list-style-type: none"> 1. Bearing(s) worn and/or fouled with dirt 2. Armature contaminated with dirt and/or oil 3. Excess wear to copper contacts on armature 	<ol style="list-style-type: none"> 1. Replace motor, submit for service 2. Replace motor, submit for service 3. Replace motor, submit for service.
Bur stops when pressure is applied, but motor continues to run	<ol style="list-style-type: none"> 1. Collet is worn or not tightened down 2. Bur shaft is worn or is wrong diameter 3. Broken connection between motor and hand piece 	<ol style="list-style-type: none"> 1. Replace hand piece, submit for service 2. Replace bur 3. Replace hand piece, submit for service
Bur slips in or out of collet when collet is in locked position	<ol style="list-style-type: none"> 1. Collet is worn or not tight 2. Chuck case is worn or not tight 3. Slots in collet are fouled with dirt and debris 4. Bur shaft is worn or is wrong diameter 	<ol style="list-style-type: none"> 1. Replace hand piece, submit for service 2. Replace hand piece, submit for service 3. Replace hand piece, submit for service 4. Replace bur
Bur wobbles or does not run true	<ol style="list-style-type: none"> 1. Bur is bent 2. Chuck case is bent or outside diameter of the shaft is worn causing bearing slack 3. Collet is bent or damaged 4. Dust seals are worn 5. Improper fit of the chuck assembly due to dirt build-up inside the top cover 	<ol style="list-style-type: none"> 1. Replace bur 2. Replace hand piece, submit for service 3. Replace hand piece, submit for service 4. Replace hand piece, submit for service 5. Replace hand piece, submit for service
Hand engine gets warm	Armature and/or brushes fouled with oil or other contaminate	Replace motor, submit for service
Low torque, weak power	<ol style="list-style-type: none"> 1. Brushes worn or dirty 2. Armature worn or dirty 	<ol style="list-style-type: none"> 1. Replace motor, submit for service 2. Replace motor, submit for service
No chip air and cooling water from hand piece	Using cleaning tool clean exit holes in the nose of the hand piece by slowly inserting and rotating the tool into the exit holes	Using cleaning tool clean exit holes in the nose of the hand piece by slowly inserting and rotating the tool into the exit holes

6.2 Vacuum Supply Subsystem

PROBLEM	POSSIBLE CAUSES	RESPONSE OR CORRECTIVE ACTION
No vacuum	<ol style="list-style-type: none"> 1. Failed vacuum pump 2. Blocked vacuum line 3. Bad electrical connection 4. Waste container full 5. Vacuum leak from hoses and/or fittings 6. Vacuum shut-off valve blocked/stuck 	<ol style="list-style-type: none"> 1. Replace vacuum pump 2. Clear or replace vacuum line 3. Clean or replace electrical connection 4. Empty waste container 5. Check and tighten all connections 6. Check and clean shut-off valve
Low vacuum	<ol style="list-style-type: none"> 1. Worn or low performance from vacuum pump 2. Vacuum leaks from hoses and/or fittings 3. Blocked vacuum line 	<ol style="list-style-type: none"> 1. Replace vacuum pump 2. Check and tighten all connections 3. Clear or replace vacuum line
Vacuum pump will not start	<ol style="list-style-type: none"> 1. Vacuum in the pump head 2. Thermal shut-off activated 3. Failed vacuum pump 4. Bad electrical connection 5. Bad ON/OFF switch 4. Failed control circuit board 5. Failed power relay 	<ol style="list-style-type: none"> 1. Release vacuum from pump head, connect tubing or fitting to vacuum connection on back of base unit 2. Let the motor cool down until warm to the touch 3. Replace vacuum pump 4. Clean or replace electrical connection 5. Replace switch 6. Test circuit board, see paragraph 6.4 7. Replace relay

6.3 Air and Water Supply Subsystems

PROBLEM	POSSIBLE CAUSES	RESPONSE OR CORRECTIVE ACTION
Low or no water flow to hand piece	<ol style="list-style-type: none"> 1. Low air pressure 2. Blocked water line 3. Failed water ON/OFF switch 4. Failed control circuit board 5. Stuck water flow control needle valve 6. Blocked water filter 7. Low water level in reservoir 8. Failed or stuck water flow control solenoid 	<ol style="list-style-type: none"> 1. Turn on compressor, check for air leaks 2. Unblock or replace water line 3. Check circuit board, see paragraph 6.4 4. Check circuit board, see paragraph 6.4 5. Check needle valve and replace 6. Unblock or replace water filter element 7. Add water to reservoir 8. Test water solenoid and replace
Low air pressure	<ol style="list-style-type: none"> 1. Compressor bleed solenoid stuck OPEN 2. Main circuit board failure 3. Compressor will not start 4. Blocked air line 5. Worn compressor 6. Air leaks from tubing and/or fittings 7. Misadjusted pressure regulator 8. Misadjusted pressure relief valve on compressor 	<ol style="list-style-type: none"> 1. Check voltage to solenoid, if 12 VDC replace solenoid, if no voltage replace main circuit board 2. Replace main circuit board 3. Check compressor relay, check voltage to compressor, replace relay or compressor 4. Unblock or replace air line 5. Replace compressor 6. Tighten or replace fittings 7. Adjust pressure regulator 8. Adjust pressure relief valve
Compressor will not start	<ol style="list-style-type: none"> 1. Failed compressor 2. Bad electrical connection/wiring 3. Failed control circuit board 4. Failed power relay 	<ol style="list-style-type: none"> 1. Replace compressor 2. Check connections and wiring, replace 3. Check circuit board, see paragraph 6.4 4. Replace power relay
Water leak	<ol style="list-style-type: none"> 1. Bad o-ring 2. Hole in water line 3. Loose fitting 	<ol style="list-style-type: none"> 1. Replace o-ring 2. Replace water line 3. Tighten or replace fitting

6.4 Electronics

FUNCTION OR COMPONENT	INDICATION OR TEST PROCEDURES	RESPONSE OR CORRECTIVE ACTION
Main Power Reset	LEDS do not light up	<ol style="list-style-type: none"> 1. Cycle power switch. 2. Check power cord and outlet have AC voltage present. 3. Check fuse on Voltage Selector circuit board. 4. Check all connections to main circuit board 5. Check connections to control panel circuit board 6. Replace Keypad Display Panel 7. Replace main circuit board 8. Replace control panel circuit board
	LED's active but does nothing when button pressed	<ol style="list-style-type: none"> 1. Cycle power switch. 2. Press another button, if LED's reset now, then replace Keypad Display Panel. (bad button) 3. Replace main circuit board
Power Supply Operation	A problem exists so first check the power supply to the main circuit board.	<ol style="list-style-type: none"> 1. Remove the connector from J4 and verify the voltages are present on the connector plug. 2. Pins 1 and 2 are 5.0V +/- 0.5V 3. Pins 3 and 4 are 5.0V +/- 0.5V 4. Pins 5 and 6 are 12.0V +/- 0.5V 5. Pins 7 and 8 are 31.0V +6.0V/-1.0V 6. Replace the power supply if any one of these voltages do not pass. 7. Reconnect the connector to J4 and verify each of the power supply voltages again. Replace the main circuit board if any of the voltages fails.
Compressor Operation	Nothing happens when button pressed	<ol style="list-style-type: none"> 1. Replace the Keypad Display Panel 2. Replace the Main Circuit Board.
	Compressor starts but LED does not light	<ol style="list-style-type: none"> 1. Replace the Keypad Display Panel 2. Replace the Main Circuit Board.

FUNCTION OR COMPONENT	INDICATION OR TEST PROCEDURES	RESPONSE OR CORRECTIVE ACTION
Compressor Operation (continued)	LED lights but compressor does not start	<ol style="list-style-type: none"> 1. Verify the air reservoir pressure is below 15 psi. 2. Remove the connector on J8 and verify the voltage on pins 5 and 6 is 12VDC +/- .5 V, if it is not replace the main circuit board 3. Re-connect the connector to plug J8 and verify the voltage is present on the input terminals of the Motor Control Relay. If not repair/replace the wiring. 4. Verify that there is a voltage present on one of the pins on the output of the compressor control relay. Activate the compressor and verify that the voltage is now present on both output pins of the compressor control relay. If it is not replace the relay. 5. Check the wiring from the relay to the compressor. 6. If running on 115 VAC, check that the two voltage selector relays are energized when power is applied to the unit.
	Compressor does not shut off when pressure rises above 60 PSI	<ol style="list-style-type: none"> 1. Check the tubing to the pressure sensor P2 on the main circuit board and repair 2. Check the adjustment on the pressure regulator, if it is set below the shut-off pressure of the P2 the circuit board will not shut-off the compressor, adjust as necessary 3. Check the setting of the pressure relief valve on the compressor, adjust as needed. 4. Replace the main circuit board
	Compressor does not restart when the pressure drops below 40 PSI	<ol style="list-style-type: none"> 1. Replace the main circuit board
Vacuum pump operation	Nothing happens when button pressed	<ol style="list-style-type: none"> 1. Replace Keypad Display Panel 2. Replace main circuit board
	Vacuum starts but LED does not activate	<ol style="list-style-type: none"> 1. Replace Keypad Display Panel 2. Replace main circuit board

FUNCTION OR COMPONENT	INDICATION OR TEST PROCEDURES	RESPONSE OR CORRECTIVE ACTION
Motor operation	Nothing happens when the motor ON/OFF button is pressed	1. Replace Keypad Display Panel 2. Replace main circuit board
	LED doesn't light when motor ON/OFF button is pressed but motor runs	1. Replace Keypad Display Panel 2. Replace main circuit board
	Panel LED is ON, Motor LED is ON The motor doesn't start after repeated pressing of the speed up button.	1. Remove the connector on J9 and verify the voltage on pins 6 and 7 is greater than 3.0V and less than 30V, if it is not replace the main circuit board 2. Re-connect the connector to plug J9 and verify the voltage is present on the output terminals of the Motor connector. If not repair/replace the wiring. 3. Replace the motor handpiece and/or power cable.
	Motor does not stop when footswitch released or motor speed adjusted down with speed decrease buttons	1. Adjust motor low speed potentiometer, if still won't stop replace main circuit board, see Figure 5.8.1-1
	Motor does not seem to reach maximum speed when foot switch depressed all the way or speed adjusted to maximum with speed increase buttons	1. Check adjustment of motor maximum speed potentiometer, see Figure 5.8.1-1 2. Replace main circuit board
Motor speed indication operation	Last LED does not illuminate when motor at maximum speed	1. Check adjustment of motor maximum speed potentiometer, see Figure 5.8.1-1 2. Check speed indicator LED adjustment, see Figure 5.8.1-1 3. Replace main circuit board
Fiber optic operation	Nothing happens when the Fiber Optic button is pressed	1. Replace Keypad Display Panel 2. Replace main circuit board
	LED doesn't light when Fiber Optic button is pressed but light turns ON.	1. Replace Keypad Display Panel 2. Replace main circuit board

FUNCTION OR COMPONENT	INDICATION OR TEST PROCEDURES	RESPONSE OR CORRECTIVE ACTION
	The Fiber Optic LED is ON but nothing happens.	<ol style="list-style-type: none"> 1. Remove the connector on J9 and verify the voltage on pins 4 and 5 is 3.0V, if it is not replace the main circuit board 2. Re-connect the connector to plug J9 and verify the voltage is present on the output terminals of the Motor connector. If not repair/replace the wiring. 3. Disassemble the handpiece and check the resistance of the Fiber Optic bulb, if it is infinite replace the bulb.
	The Fiber Optic light does not turn OFF	<ol style="list-style-type: none"> 1. Replace the main circuit board
	The Fiber Optic intensity control doesn't work.	<ol style="list-style-type: none"> 1. Remove the connector from J7 and verify that 5.0V +/- 0.5V is present. If not then replace the main circuit board. 2. If 5.0V +/- 0.5V is present then replace the adjustment pot.
Cooling Air to Motor	Motor starts but cooling air doesn't flow	<ol style="list-style-type: none"> 1. Remove the connector on J3 and start the motor. Verify the voltage on pins 1 and 2 is 12.0VDC, if it is not replace the main circuit board 2. Turn off the air and water. With the motor running, re-connect the connector to plug J3 and verify the solenoid makes a click. If not repair/replace the wiring and/or solenoid.
Air Supply for handpiece	Nothing happens when the Handpiece Air Button is pressed and the motor is running.	<ol style="list-style-type: none"> 1. Replace Keypad Display Panel 2. Replace main circuit board
	LED doesn't light when Handpiece Air button is pressed but air comes out when motor starts.	<ol style="list-style-type: none"> 1. Replace Keypad Display Panel 2. Replace main circuit board
	LED lights but no air comes out when motor is running.	<ol style="list-style-type: none"> 1. Remove the connector on J3 and start the motor. Verify the voltage on pins 3 and 4 is 12.0V, if it is not replace the main circuit board 2. Start the motor and reconnect the connector to plug J3. Cycle the button for the Handpiece Air and verify the solenoid makes a click. If not repair/replace the wiring and/or solenoid. 3. Check the needle valve and replace if blocked. 4. Adjust/replace the Handpiece air flow tubing

FUNCTION OR COMPONENT	INDICATION OR TEST PROCEDURES	RESPONSE OR CORRECTIVE ACTION
Water Supply for handpiece	Nothing happens when the Handpiece Water Button is pressed and the motor is running.	<ol style="list-style-type: none"> 1. Check that needle valve is OPEN 2. Replace Keypad Display Panel 3. Replace main circuit board
	LED doesn't light when Handpiece Air button is pressed but water comes out when motor starts.	<ol style="list-style-type: none"> 1. Replace Keypad Display Panel 2. Replace main circuit board
	LED lights but no water comes out when motor is running.	<ol style="list-style-type: none"> 1. Remove the connector on J3 and start the motor. Verify the voltage on pins 5 and 6 is 12.0V, if it is not replace the main circuit board 2. Start the motor and reconnect the connector to plug J3. Cycle the button for the Handpiece Water and verify the solenoid makes a click. If not repair/replace the wiring and/or solenoid. 3. Check the needle valve and replace if blocked. 4. Adjust/replace the Handpiece air flow tubing and/or water tubing.
Enclosure Cooling Fan	Power is turned on but fan doesn't run	<ol style="list-style-type: none"> 1. Remove the connector on J8 and turn on the power. Verify the voltage on pins 1 and 2 is 12.0VDC, if it is not replace the main circuit board. 2. Replace the fan and/or wiring to fan.
Foot Switch Operation	Motor doesn't start when foot switch is pressed.	<ol style="list-style-type: none"> 1. Verify that the operation mode selected is remote. 2. Verify that the motor is turned on. 3. Verify that the low air led isn't activated. If it is then press the motor speed up button once. 4. Remove the connector on J9 and verify the voltage between pins 1 and 3 is 5.0V +/- 0.5V. Replace main circuit board if it is not. 5. Re-connect the connector to J9 and verify the voltage is present on the output pins of the foot switch connector. Replace the foot switch wiring if not. 6. Connect the foot switch and measure the voltage between pins 3 and pin 2 while moving the footswitch. If the voltage is GND then replace the foot switch. If the voltage moves between GND and 5.0V then replace the main circuit board.

FUNCTION OR COMPONENT	INDICATION OR TEST PROCEDURES	RESPONSE OR CORRECTIVE ACTION
Auto-Voltage Selector	The two relays are not energized.	<ol style="list-style-type: none"> 1. If the unit is operating on 230 VAC this is normal operation. 2. Check that the 4 pin connector is securely plugged into J4. 3. Check the wiring to the control relays. 4. Verify that +12 VDC is present on the emitters of Q1-4. Replace D1 or U1. 5. Verify that the voltage at the junction of R4, R5, and R6 is less than or equal to 11.3 VDC. If not then replace circuit board. 6. Verify the voltage at the top of R7 is greater than 11.4 VDC. If not then replace Q1. 7. Verify the voltage at the top of R8 is less than or equal to 11.4 VDC. If not then replace Q2. If it is then replace Q3 and Q4.
	Only one relay is energized.	<ol style="list-style-type: none"> 1. Swap the two relays. Replace the non functioning relay if it still does not energize when placed in the other socket. 2. Check the wiring from the Voltage Control circuit board to the relay sockets. 3. Verify that the voltage at pin 3 of J4 is about 12 VDC. If not then replace Q3. 4. Verify that the voltage at pin 2 of J4 is about 12 VDC. If not then replace Q4. 5. If replacement parts are not readily available, exchanging the red wires from J4 pins 2 and 3 to the relays can make the compressor temporarily operational. Remove the non-functioning relay to avoid damaging any equipment plugged into the auxiliary 115 VAC output jack on the front panel with the incorrect voltage.
Voltage Control Circuit Board		
Check the voltage control switches when connected to 110VAC	Connect to 110VAC outlet and turn power ON, the power control relays should switch, if they do not	<ol style="list-style-type: none"> 1. Check the main power circuit breakers and reset if necessary 2. Replace the Voltage Control Circuit Board

7.0 MAJOR SYSTEM COMPONENTS

This section identifies the major components inside the base unit. The components are identified in Figures 7.2-1 and 7.3-1.

- To get access to the inside of the base unit open the base unit by turning the retaining latch $\frac{1}{4}$ turn counterclockwise. Then rotate the top forward to access the inside of the base unit.



7.1 Water Subsystem Components

The water subsystem components are located in the upper right hand portion of the top of the base unit.

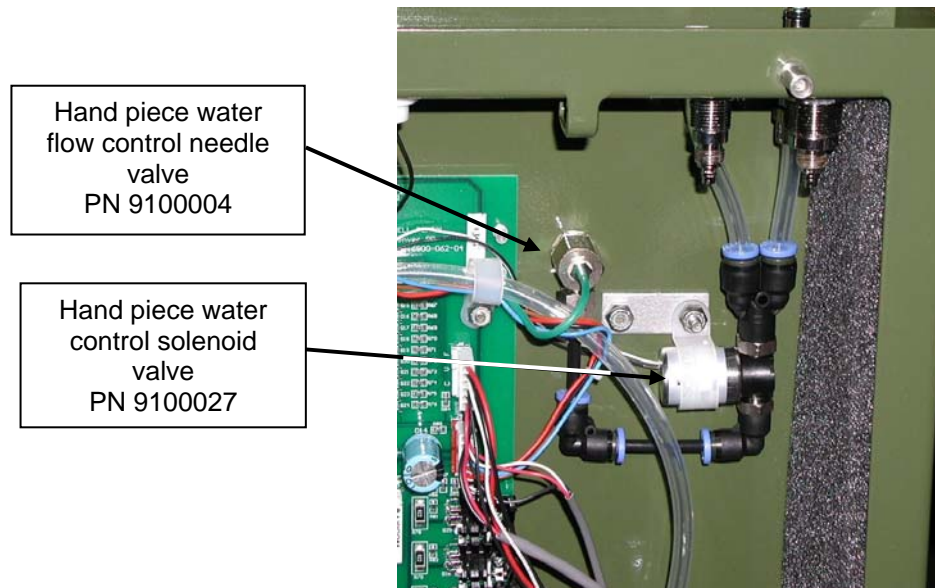

7.2 Major Components - Base Unit

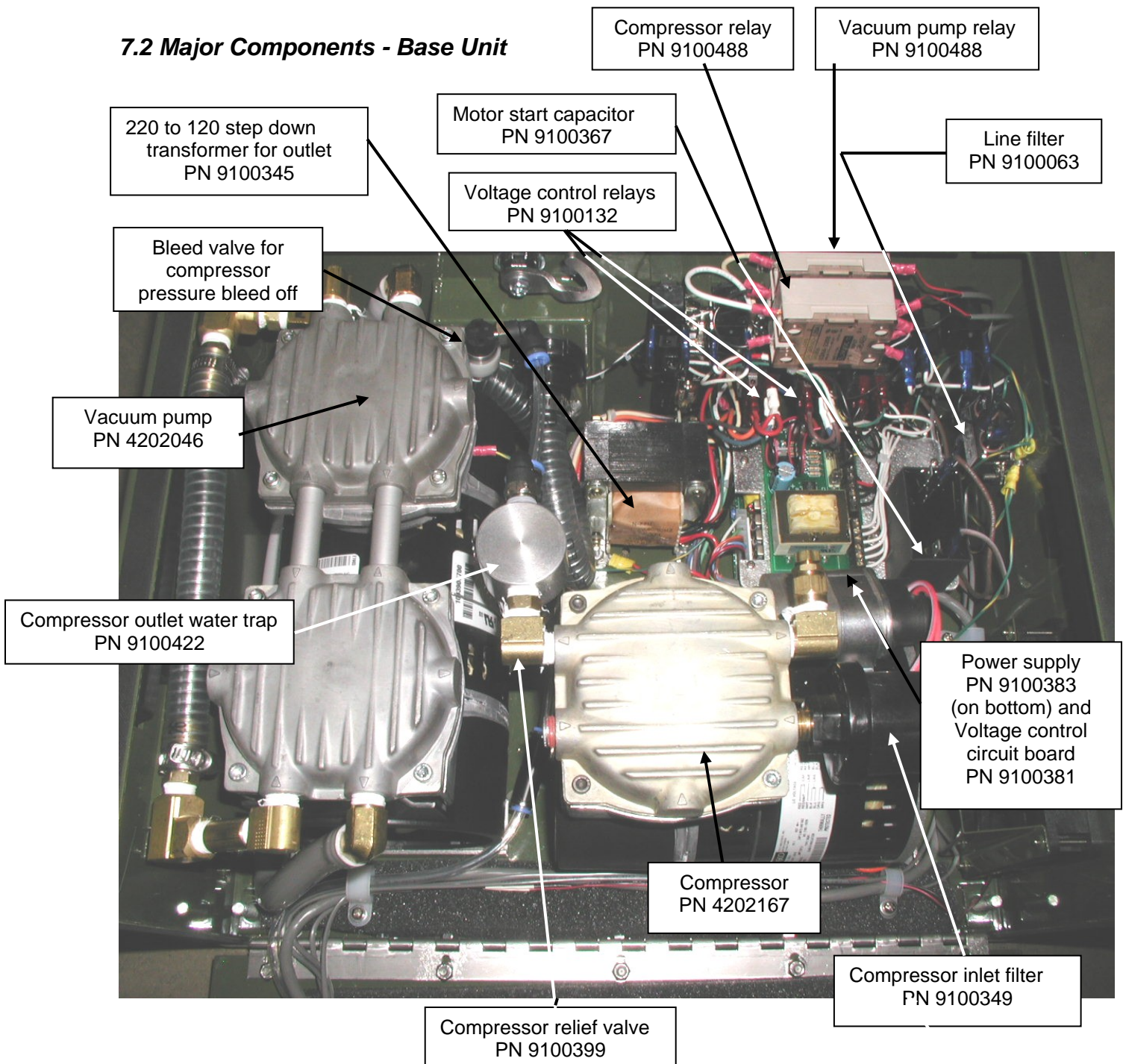

Figure 7.2-1

Major Components in Base Unit

7.3 Major Components – Top of Unit

Figure 7.3-1

Major Components on Top of Unit

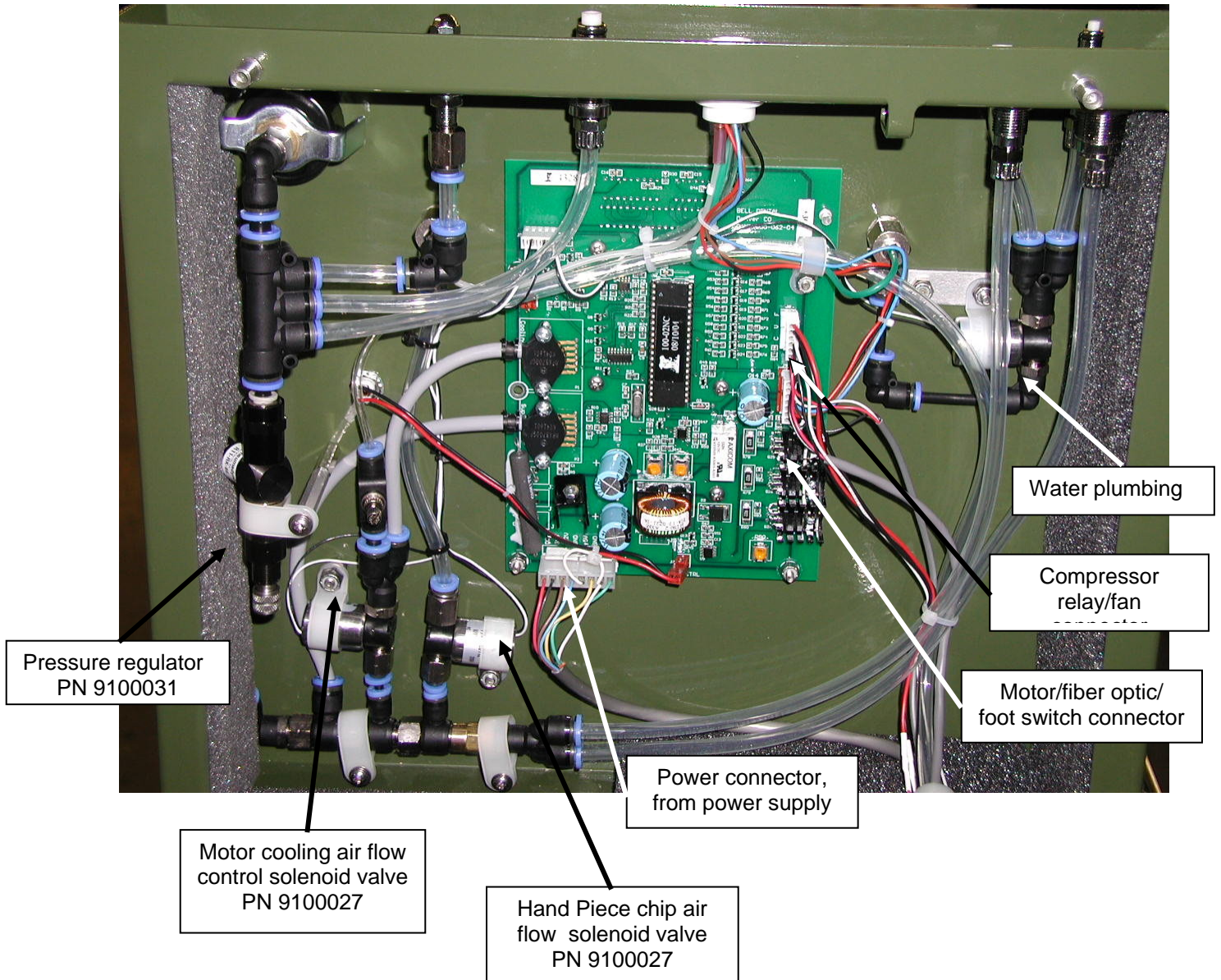

© 2006 Bell Dental Products, LLC. All rights reserved. No portion may be copied or reproduced without express written permission from Bell Dental Products, LLC.

8.0 WARRANTY

Bell Dental Products LLC warrants this product against defects in materials or workmanship for one year from the time of shipment. Bell Dental Products LLC will pay labor for warranty service for a period of **1 year** from the time of delivery. This warranty does not cover consumable items including light bulbs.

Bell Dental Products, LLC sole obligation under said warranty is to repair, or at its option, replace the defective part. The buyer shall have no other remedy. All special, incidental, and consequential damages are specifically excluded.

The warranty shall be voided by alterations of the equipment, except by Bell Dental Products LLC or with Bell Dental Products LLC approval, or tampering with, improper installation or maintenance, accident, or misuse. This warranty expressly excludes all damage to these products resulting from careless or neglectful transportation or acts of military operations.

Repairs during the warrant period may be performed by a certified technician. In that event Bell Dental Products, LLC sole responsibility shall be to provide the appropriate replacement parts when submitted to Bell Dental Products for replacement.

This warranty is made expressly in lieu of all other warranties, expressed or implied, including any implied warranties of merchantability or fitness for particular purpose. No employee, agent, franchise, dealer, or other person is authorized to give any warranties of any nature on behalf of Bell Dental Products, LLC. Except as provided herein, Bell Dental Products, LLC shall have no liability or responsibility to customer or any other person or entity with respect to any liability, loss or damage caused or alleged to be caused directly or indirectly by "equipment". Notwithstanding the above limitations and warranties, Bell Dental Products, LLC liability hereunder for damages incurred by customer or others shall not exceed the amount paid by customer for the particular "equipment" involved.

9.0 CUSTOMER SERVICE

In the event assistance is required in the set-up, operation, maintenance, or repair of the PortaBELL™ DeFTOS, contact Bell Dental Products, LLC Customer Service at customerservice@belldental.com or at (800) 920-4478. Service hours are from 8:00 a.m. to 5:00 p.m., Mountain Time, USA, Monday through Friday, excluding holidays.

© 2006 Bell Dental Products, LLC. All rights reserved. No portion may be copied or reproduced without express written permission from Bell Dental Products, LLC.

10.0 SPECIFICATIONS

Volume: (Unit only)	0.09 m ³ (1.5 ft ³) L: 13.25 inches H: 13.25 inches W: 15.5 inches
Weight (including shipping container):	93 pounds (42.3 kg)
Electrical Power:	100 to 240 VAC 50/60 Hz 6A, Dental Unit only 8A Dental Unit and AC Receptacle
Power:	420 W, Dental Unit
Power cord:	10 foot, hospital grade Schuko
Air pressure:	
Max expected operating pressure	60 PSI, controlled by pressure regulator
Max Air storage tank pressure	125 PSI protected by pressure relief valve
Airflow of compressor:	0.9 CFM
Waste container capacity:	1.5 li
Water reservoir capacity:	500 ml
Air/water syringe water flow	270 ml per minute
Cooling fan airflow:	85 CFM
Vacuum:	4.0 SCFM @ 4 in Hg
Noise:	<65 dB A @ 1 meter
Motor:	
Speed:	40,000 rpm
Torque:	500 gm-cm
Hand piece connection:	E-type
Disinfection:	Wipe (motor cover is steam autoclavable) DO NOT AUTOCLAVE MOTOR
Hand Piece	Any E-type connector
Ratios:	1:5 contra angle with fiber optics (200,000 RPM max) 2.7:1 reduction contra angle with fiber optics 10:1 reduction contra angle with fiber optics Straight hand piece without fiber optics Steam autoclavable hand pieces, wipe motor
Disinfection:	
Fiber Optics	
Illumination:	70,000 LUX
Power	Nominal: 3.5 VDC, Max: 4.0 VDC
Temperature:	Operating: 35°F to 120°F (2°C to 49°C) Storage: -40°F to 140°F (-40°C to 60°C)
Humidity:	95 percent non-condensing
Altitude:	up to 3000 m (10,000 ft)

APPENDIX A – System Parts List

BDP P/N	Description
4202001	Air Tank hose assembly
9100390	QD Coupler, inline, barb w/ SO, Ni plated brass, 1/4" ID
9100391	QD, insert, inline, barb, w/S-O, Ni plated brass, 1/4" ID
9100094	Hose, 1/4" dia
9100069	Clamp, screw type
4201003	Air Tank assembly
9100458	Air tank (change warning label)
9100254	Valve, relief
9100394	QD Recep, 1/4" NPT
4202004	3-way syringe assembly
9100085	3-way syringe
9100173	QD insert, inline, poly p, w/o SO, 1/16
9100170	QD Insert, Inline Barb 1/16" Acatel w/o SO
4202005	Waste container to base hose assembly
9100163	QD insert, inline, barb, poly p, w/o SO 1/2" Straight BLK
9100274	QD Insert 1/2"NPT, w/o SO, White
9100096	Tubing, 1/2" dia
9100272	Elbow, 1/2" NPT, F-F, nylon
9100271	Nipple, 1/2" NPT, M-M, Nylon
9100273	Elbow, 1/2NPT to 1/2 barb
9100151	Water trap, Vacuum
9100148	Clamp, spring, 1/2 tube
4202007	HVE hose assembly
9100165	QD, insert, 1/2 barb, grey, w/o so
9100096	Tubing, 1/2" dia
9100005	Valve, HVE
9100148	Clamp Spring Band 1/2" Tubing
4202008	Saliva Ejector hose assembly
9100181	QD, insert, 3/16 barb, w/o so
9100084	Tubing, 3/16" dia
9100006	Valve, Saliva ejector
9100508	Clamp, spring, for 3/8 tubing

APPENDIX A – System Parts List (continued)

BDP P/N	Description
4202013	Water bottle and manifold assembly
9100080	Water bottle
9100192	Manifold assy (RAW)
9100392	QD, insert, inline, ferrules, w/ SO, .170
9100179	QD Recept. line Ferrules Chrome-Brass w/SO .170
9100009	Filter, Inline, water, 1/8" barb
9100176	Clamps, one ear, 5/16, 8mm
4202041	Instrument tray assembly
9100261	Instrument tray frame
9100045	Instrument tray
9100033	Hand piece holder, for saliva and syringe
9100032	Hand piece holder, for motor and HVE
4202049	Waste container assembly
9100491	Waste container "jar"
9100484	Waste container top, modified (mod cost)
4202028	QD, recep, machined, for waster container top, MODIFIED (HVE)
9100535	Seal, valve, 1/2 flow
9100536	Nut, lock 1/2 flow
4202050	QD Insert, Inline Barb Acetal w/o SO 3/16" modified (Saliva)
9100537	Nut, lock 1/8 flow
9100537	Seal, valve, 1/8 flow
4202002	Vacuum Shut-off Valve
9100388	QD fitting (modified) (S/O valve)
9100221	Float ball
9100359	S/O valve body
9100516	Valve seat
9100535	Seal, valve, 1/2 flow
9100536	Nut, lock 1/2 flow
4202053	Operating and Maintenance Manual, PortaBELL III
4202160	Foam insert, Lid, back, PortaBELL™ II
9100086	Power cord, 3-prong
9100087	Storage pouch 1
9100088	Storage pouch 2
9100222	Support pole
9100223	Extension arm
9100259	Shipping container

APPENDIX A – System Parts List (continued)

BDP P/N	Description
9100260	Solids trap
9100286	Motor tubing
9100361	Bracket assembly for waste container and water bottle
9100368	Foam insert
9100452	Bio Lube™, E-formula, hand piece lubricant 16 oz can, non-flammable propellant
9100453	Bio Lube™ Hand piece Cleaner, 16 oz can, non-flammable propellant
9100520	O-ring, 1/8" (Water inlet/Air Syr)
9100521	O-ring, 1.78mm dia, 1/4" (Water M)
9100522	Gasket, for vacuum water trap
9100523	O-ring, .047 Flow (Water Syr)
9100533	O-ring, 3/8" & 1/2" Waste Container
9100534	O-ring, Inline Filter, Water, 1/8" Barb
9100535	Gasket, for large CPC fittings
9100541	Storage pouch 3
9100542	Storage pouch 4
9400020	Straight hand piece, w/internal air/water
9400022	Motor (MC3)
9400051	Foot switch assembly
9400067	Contra Angle, 2.7:1
9400074	Power cord, Schuko
9400081	Spraynet hand piece cleaner
9400082	Lubrifluid® hand piece lubricant
9400094	Quick Connector for MC3 Motor (Coupling)
9400099	Manual, HVE
9400100	Manual, MC3 motor
9400101	Manual, 10:1 reduction hand piece
9400103	Manual, straight hand piece
9400104	Manual, 1:5 increaser hand piece
9400225	Contra Angle, 1:5 increaser
9400229	Flow meter, to check motor cooling air flow
9400230	Ground cable assembly
9400233	Grease, conductive (for ground lug) (tube)
	Housing Top Assembly
4202151	Label, front (grey)
4202160	Foam pad
9400238	Housing, Top
9100004	Valve, Needle, Panel mount
9100030	Gauge Pressure, Panel Mount, 160 psi
9100048	Knob, 1/2", goes with needle valve

© 2006 Bell Dental Products, LLC. All rights reserved. No portion may be copied or reproduced without express written permission from Bell Dental Products, LLC.

APPENDIX A – System Parts List (continued)

BDP P/N	Description
9100061	Clamp, spring, for 1/4 OD tubing (for press sensor)
9100064	Nylon Washer
9100198	Clamp, Plastic 3/4" Dia.,white (For Solenoid)
9100256	Locater Pins
9100282	Plug, 1/2" Black Plastic (for PortaBELLhousing)
9100375	Extension, Water Solenoid PEM
9100386	Potentiometer, Fiber Optic Intensity
9100401	Tubing, 1/4" Clear, Poly P, .160 ID, 95 Durometer (in ft)
9100403	Push-in, Straight, 1/4" to 10-32
9100404	QD, Insert, Panel Mount, 1/4" OD. ,1/4" Flow,Ferruleless w/s-o
9100409	QD Receptacle, 1/4" OD, 1/8" Flow,Panel Mount, Ferruleless w/s-o
9100410	QD Receptacle, 1/4" OD, 1/4" Flow,Panel Mount, Ferruleless w/s-o
9100411	QD Insert, Panel Mount, 1/4" OD. ,1/8" Flow, Ferruleless w/s-o
9100412	Spacer, 6mm x 4.4mm ID (for main CB spacer)
9100413	Push-in, Straight, 10-32 to 5/32" tube
9100464	Barb, 10-32 Ni Plated, 1/16"
9100514	Push-in, elbow, 1/4 to 1/8 NPT Female
9100519	QD, Panel, Acetal, .047 Flow, 1/8 barb, w/SO (Syr water)
9100525	Clamp, 5/8, nylon
9400094	Q.C., MC3 Motor
9400223	Valve, tire, machined
9400228	Gasket, strip, from 9100154, for PortaBELL top seal
PPH632x.5	Screw, #6-32 x 1/2" PPH
SOFF632x1	Standoff, F-F, 6-32, 1"
SOMF632x1.75	Standoff, M-F, 6-32, 1.750 (Dist manifold support)
	Pressure Gauge Tubing Assembly
9100401	Tubing, 1/4" Clear, Poly P, .160 ID, 95 Durometer (in ft)
9100406	Push-in, elbow, 1/4-1/4 F
9100494	Push-in, elbow, 1/4 x 1/4 tube, M-F
9100499	Push-in Reducer, tube, 5/16" to 1/4"
9100501	Push-in, Regulator, pressure, 1/4
9100503	Push-in, triple branch, In: 5/16, Out: 1/4
	Water Tubing Assembly
9100027	Valve, solenoid, 12 V DC inline, NC
9100421	Tubing, 5/32, (in in) Clear
9100423	Push-in, elbow, 5/32 to 10-32
9100425	Push-in, Y, 10-32 to 1/4
9100497	Push-in, elbow, 5/32 tubing

APPENDIX A – System Parts List (continued)

BDP P/N	Description
	Air Manifold Tubing Assembly
9100027	Valve, solenoid, 12 V DC inline, NC
9100401	Tubing, 1/4" Clear, Poly P, .160 ID, 95 Durometer (in ft)
9100403	Push-in, Straight, 1/4" to 10-32
9100413	Push-in, Straight, 10-32 to 5/32" tube
9100419	Push-in, elbow, 1/4" to 1/8" M NPT
9100421	Tubing, 5/32, (in in) Clear
9100425	Push-in, Y, 10-32 to 1/4
9100496	Push-in, T, 1/8 F NPT, 1/4, 1/8 M NPT
9100498	Push-in, T, 1/8 F NPT, 5/32, 1/8 M NPT
9100500	Coupler, 1/8" NPT, Brass
9100509	Push-in, reducer, 1/4 to 5/32
9100513	Push-In, Y, 1/4 to 1/8 NPT Male
G920054000	Teflon Tape
	Button/Main Circuit Board Sub-assembly
4202178	Circuit Board, Main, PortaBELL III
9100376	Circuit Board, PortaBELL II & III (Touch Panel)
SOFF632x1/4	Standoff, F-F, 6-32, .250 (Main CB to Touch Panel spacer)
SPPH632x.375	Screw, 6-32x.375, Round head, phillips
WF06	Washer, Flat, #6 (Main CB spacing)
	Housing Bottom Assembly
4202015	Vacuum Pump Cable Restraint assembly
4202021	Filter element, air inlet (on the side)
4202100	Cable assembly, Foot switch connector to Main CB
4202101	Cable assembly, Power supply to Main CB
4202102	Cable assembly, Compressor relay to Main CB
4202104	Cable assembly, compressor ground
4202150	Label, touch panel (grey)
4202152	Label, Vac recess (grey)
4202153	Spacer, touch panel
4202173	Handles, Screw in for PortaBell housing
4202174	Voltage Control and Plate
4202175	Cover, Electric PB III
4202181	Label, Vacuum Recess, PB III
4202182	Label, Top, PB III
9100035	Fan Motor Guard 120mm, 41/2"
9100036	Fan Motor Retainer 120mm, 41/2"
9100057	Circuit breaker, 2A, thermal, w/nut

© 2006 Bell Dental Products, LLC. All rights reserved. No portion may be copied or reproduced without express written permission from Bell Dental Products, LLC.

APPENDIX A – System Parts List (continued)

BDP P/N	Description
9100061	Clamp, spring, for 1/4 OD tube (for press sensors)
9100063	Filter, EMI
9100064	Washers, Nylon, For 10/32 Thread
9100066	Circuit Breaker, thermal 10A, w/nut
9100075	Clamp, Plastic 1/2" Dia. (For Wiring)
9100100	Outlet, duplex, Hospital Grade, brown
9100132	Relay
9100155	Top Latch, Turn 1/4", w/nut and gasket
9100162	QD recep, panel, barb, Poly P, w/S-O 1/2" BLK, w/nut and gasket
9100167	Connector, 2 Pos. Recpt. Molex, .100
9100220	Hinge Plate Mount Metal for New Compressor
9100334	Fan, Brushless, DC 4"
9100238	Housing, Bottom PortaBELL III (raw)
9100244	Power Receptacle, Three Prong w/ Switch
9100247	Cover, vent (green)
9100251	Machined Latch hook (for Portabell)
9100322	Valve, Solenoid, Inline, 10-32 port, NO, compressor exhaust
9100343	Connector, Footswitch, Panel, weather resistant, w/nut
9100345	Transformer, step down 220 to 110
9100347	Vibration Isolator for GAST Compressor and vacuum pump
9100378	Foot, Rubber 1"dia 5/16"-20 Thread
9100427	Plate Metal, Vacuum/Compressor Mount
9100434	Connector, Molex, 3 position, white
9100447	Cable, 2 conductor, 22AWG min, stranded (for comp and vac pump relay cables)
9100452	Cable, 3 conductor, 22AWG min, stranded (for foot switch cable)
9100488	Relay, solid state, 12VDC input, 20A output
9100505	Push-in, elbow, 10-32 to 1/4 tubing
9100515	Connector, Molex, .100, 7 circuit
9100526	Connector, spade, 18-22 AWG, Fully Insulated, #6-8 stud
9100527	Clamp, 5/8 to 3/4 geared, stainless steel
9100544	Wire, 16-18GA, stranded, black
9100545	Wire, 16-18GA, stranded, white
9100565	Fuse, 10A, Slo-Blo, 5mmx20mm
9400036	Power supply, switching, Input, 110-220, Output 5V, 12V, 36V
9400094	Quick Connector for MC3 Motor (Coupling)
9400233	Grease, conductive (for ground lug)
9400237	Housing, Bottom
B1/4-20x.5	Bolt, 1/4-20x.5 (Comp mtg and gnd lug)

© 2006 Bell Dental Products, LLC. All rights reserved. No portion may be copied or reproduced without express written permission from Bell Dental Products, LLC.

APPENDIX A – System Parts List (continued)

BDP P/N	Description
N1/4-20	Nut, 1/4-20
NL10-32	Nut, 10-32, self locking (hinge, Cap,
NL632	Nut, 6-32, self locking
NL832	Nut, 8-32, self locking
SOFF440x.375	Standoff, F-F, 4-40, .375 (PS spacer)
SOMF632x1	Standoff, M-F, 4-40, 1.375, round (Volt Ctl CB mtg plate spacer)
SPFH632x.5	Screw, 6-32X.500, flat head (side filter holder)
SPFH832x.5	Screw, 8-32x.500, flat head (Cap)
SPPH1032x.75	Screw, 10-32x.750, round head
SPPH440x.300	Screw, 4-40x.300, Round head, phillips
SPPH632x.500	Screw, 6-32x.500, Round head, phillips
SPPH632x.75	Screw, 6-32x.750, rounq head (relays??)
SPPH632x1	Screw, 6-32x1, Round head, phillips (relay??)
SPPH632x1.5	Screw, 6-32x1.5, Flat head, phillips (side filter w/fan)
WDL1/4	Washer, Spring Lock, 1/4
WF1/4x1	Washer, fender, 1/4, 1" dia (comp mtg)
WF10x1	Washer, fender, #10, 1" dia (comp hold down)
WL4	Washer, lock #4 (Volt ctl CB mtg plate, volt ctl CB)
WSL.250	Washer, star lock, 1/4 (comp hold down and gnd lug)
4202046	Vacuum Pump Assembly
4202179	Tubing, reinforced, for internal vacuum line, to exit fitting
4202180	Tubing, reinforced, for internal vacuum line, between heads
9100396	Elbow, 1/4 male x 1/4 Female, brass
9100397	Elbow, 1/4 NPT to 1/2 barb, brass
9100527	Clamp, 5/8 to 3/4 geared, stainless steel
9100549	Fitting, 1/2" Barbed 1/4" NPT
9100550	Elbow, F-F 1/4 NPT
9100551	Nipple 2"
9100552	Elbow, 1/4 NPT F-F
9400235	Vacuum Pump, 4.0CFM, (RAW)
G920054000	Tape, Teflon, 1/4"
4202167	Compressor Assembly
4202103	Cable assembly, Compressor to power electronics
9100396	Elbow, 1/4 male x 1/4 Female
9100422	Filter, Compressor Outlet, 20 Micron Filter
9100426	Nipple, Hex 1/4" NPT, brass
9100504	Push-in, elbow, 1/4NPT to 1/4 tubing
9400236	Compressor (RAW)

APPENDIX A – System Parts List (continued)

BDP P/N	Description
G920054000	Tape, Teflon, 1/4"
	Compressor Wiring Assembly
9100072	Connector, recept 18-22AWG, Fully Insulated, .187 Tab
9100384	Connector, Molex, White, inline, eight position, Insert
9100385	Connector, Molex, White, inline, eight position, Recpt.
9100443	Pins, Molex connector, Mini-Fit, 4.20mm Male CT
9100444	Pins, Molex connector, Mini-Fit, 4.20mm Recept. CT
9100526	Connector, spade, 18-22 AWG, Fully Insulated, #6-8 stud
9100545	Wire, 16-18GA, stranded, white
9100567	Q.C. 14-16
9400236	Compressor (RAW)
	Vacuum Pump Wiring Assembly
9100072	Connector, recept 18-22AWG, Fully Insulated, .187 Tab
9100074	Connector, recept 18-22AWG, Fully Insulated, .250
9100384	Connector, Molex, White, inline, eight position, Insert
9100385	Connector, Molex, White, inline, eight position, Recpt.
9100443	Pins, Molex connector, Mini-Fit, 4.20mm Male CT
9100444	Pins, Molex connector, Mini-Fit, 4.20mm Recept. CT
9100526	Connector, spade, 18-22 AWG, Fully Insulated, #6-8 stud
9100545	Wire, 16-18GA, stranded, white
9100546	Wire, 16-18GA, stranded, red
9100567	Q.C. recept 14-16AWG, Fully Insulated, .187
9400235	Vacuum Pump (RAW)
	Wiring Assembly, Circuit Breakers
9100071	Q.C. 18-22 AWG, .187, Insultated
9100074	Connector, recept 18-22AWG, Fully Insulated, .250
9100544	Wire, 18GA, stranded, black
9100545	Wire, 18GA, stranded, white
4202101	Cable Assembly, Power Supply to Main Circuit Board
9100428	Pins, Molex connector, .156
9100373	Connector, Molex Female 10Pin (power supply)
9100374	Connector, Molex Female 8Pin (CB power supply)
9100554	Cable, 8 conductor, 20AWG, stranded
	Cable Assembly, Relay - Volage Control Circuit Board
9100072	Q.C. 18-22 AWG, .187, Insulated
9100431	Connector, Molex, 4 circiut
9100476	Pins, Molex connector, .156
WIREBLK24	Wire, 24 AWG, stranded, black

APPENDIX A – System Parts List (continued)

BDP P/N	Description
WIRERED24	Wire, Red, 24AWG, UL
	Wiring, Transformer
9100072	Connector, recept 18-22AWG, Fully Insulated, .187 Tab
9100345	Transformer, step-down, 220 to 110 (Triad E50476)
9100526	Terminal, Spade, 10-12 AWG, insulated, for #8 screw
HST3/8D	Heat Shrink Tubing 3/8" Dia
WIREBLK24	Wire, 24 AWG, stranded, black
WIRERED24	Wire, Red, 24AWG, UL
WIREWHT24	Wire, 24 AWG, stranded, white
	Tubing Assembly, Compressor
9100401	Tubing, 1/4" Clear, Poly P, .160 ID, 95 Durometer (in ft)
9100405	Push-in, 1/4 T, F
9100424	Check Valve, 1/4 "John Gust
4202102	Cable Assembly, Relays (to turn Comp and Vac Pump ON/OFF)
9100156	Connector Molex 6 circuit, .100
9100373	Connector, Molex Female 10Pin (power supply)
9100428	Pins, Molex connector, .156
9100571	Cable, 2 conductor, 22AWG min, stranded
4202100	Cabling Assy, Foot Switch
9100142	Connector Molex Female 7Pos., .100
9100343	Connector, Footswitch, Panel, weather resistant, w/nut
9100544	Wire, 16-18GA, stranded, black
9100545	Wire, 16-18GA, stranded, white
9100546	Wire, 16-18GA, stranded, red
9100776	Pins, Molex connector, .156
TBD	Heat Shrink
	Cabling Assembly, Power Control Relays
9100072	Connector, recept 18-22AWG, Fully Insulated, .187 Tab
9100074	Connector, recept 18-22AWG, Fully Insulated, .250
9100544	Wire, 16-18GA, stranded, black
9100545	Wire, 16-18GA, stranded, white
	Wiring Assemblies, Ground
9100072	Connector, recept 18-22AWG, Fully Insulated, .187 Tab
9100074	Connector, recept 18-22AWG, Fully Insulated, .250
9100097	Terminal, Spade, insulated, for #6 screw
9100526	Connector, spade, 18-22 AWG, Fully Insulated, #6-8 stud
9100543	Wire, 18GA, stranded, green w/yellow stripe

APPENDIX A – System Parts List (continued)

BDP P/N	Description
	Cabling Assembly, Fan
9100334	Fan, Brushless, DC 4"
9100476	Contacts, Terminal, Crimp, Tin, Molex, .100
9100544	Wire, 18GA, stranded, black
9100546	Wire, 18GA, stranded, red
HST3/8D	Heat Shrink Tubing 3/8" Dia
	Wiring Assembly, EMI Filter
9100074	Connector, recept 18-22AWG, Fully Insulated, .250
9100545	Wire, 18GA, stranded, white
9100544	Wire, 18GA, stranded, black
	Voltage Control Circuit Board/Mounting Assembly (Conversion units)
9100381	Circuit Board, Voltage Control
9100367	Capacitor for GAST motor (Comes with Vacuum Pump)
9100380	Mounting Plate
NL832	Nut, locking, 8-32, hold down capacitor
SPFH832x.500	Screw, flat head, 8-32x.500, hold down capacitor
SPPH440X1/4	Screw, 4-40x.250, Round head phillips
STD440X3/8FF	Standoff, F-F, 4-40, .250 (Volt Ctl CB spacer)
	Voltage Control Circuit Board/Mounting Assembly (New units)
4202174	Voltage Control Circuit Board Assembly (integrated)
9100367	Capacitor for GAST motor (Comes with Vacuum Pump)
SPPH440X1/4	Screw, 4-40x.250, Round head phillips
NL832	Nut, locking, 8-32, hold down capacitor
SPFH832x.500	Screw, flat head, 8-32x.500, hold down capacitor
9100568	Cover, electric (green), PB III
WLS440	Washer, star lock, 1/4 (comp hold down and lug)
WF10	Washer, Flat, #10
WF6	Washer, Flat, #6
SPFH832x.500	Screw, flat head, 8-32x.500, hold down capacitor
NL832	Nut, locking, 8-32, hold down capacitor
SPPH632x.500	Screw, #6-32 x 1/2" PPH
NL1032	Nut, Locking, #10-32
NL440	Nut, Locking 4-40

APPENDIX B – Schematics and Parts Lists

Main Circuit Board Schematics

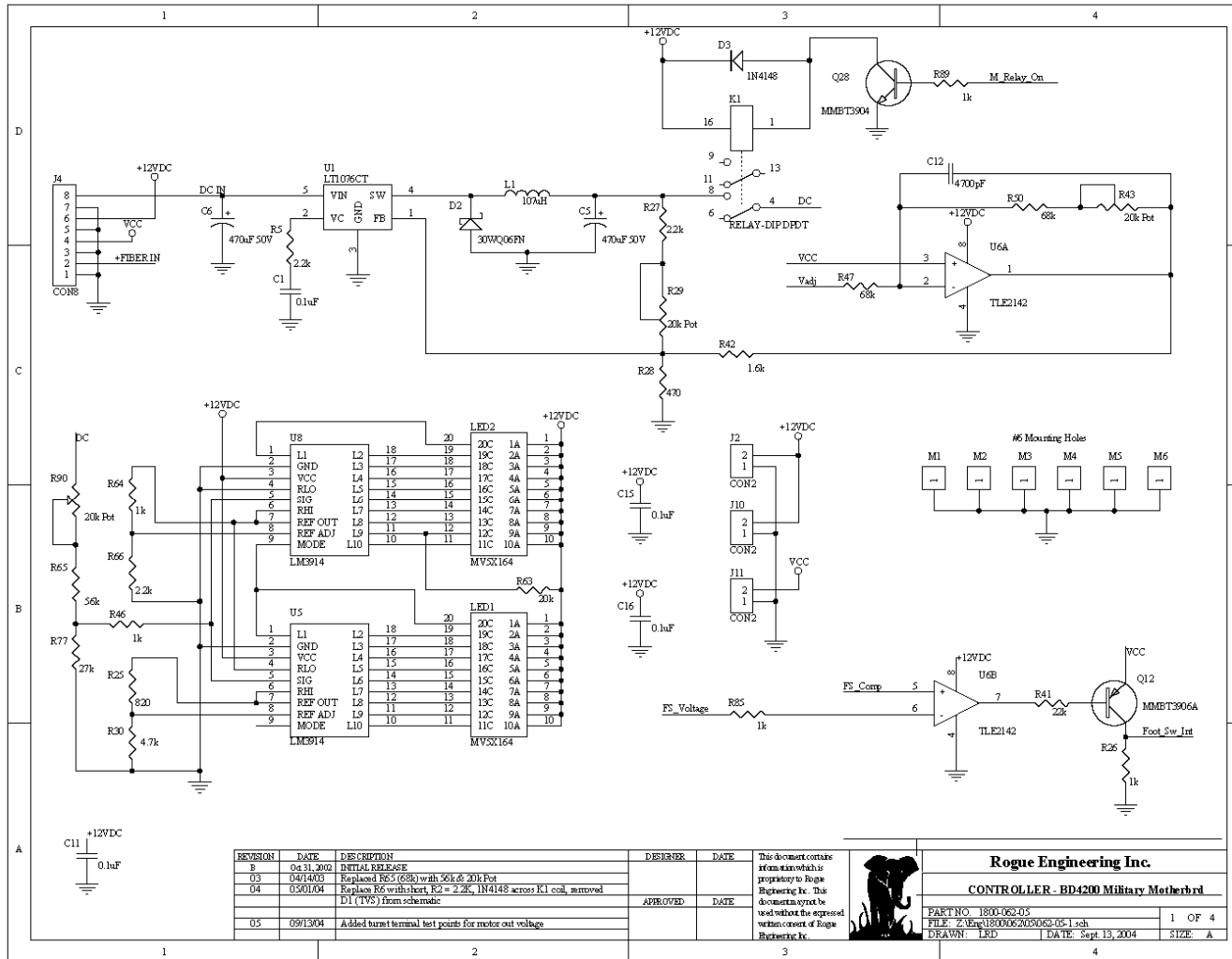

Main Circuit Board Schematics – Page 2

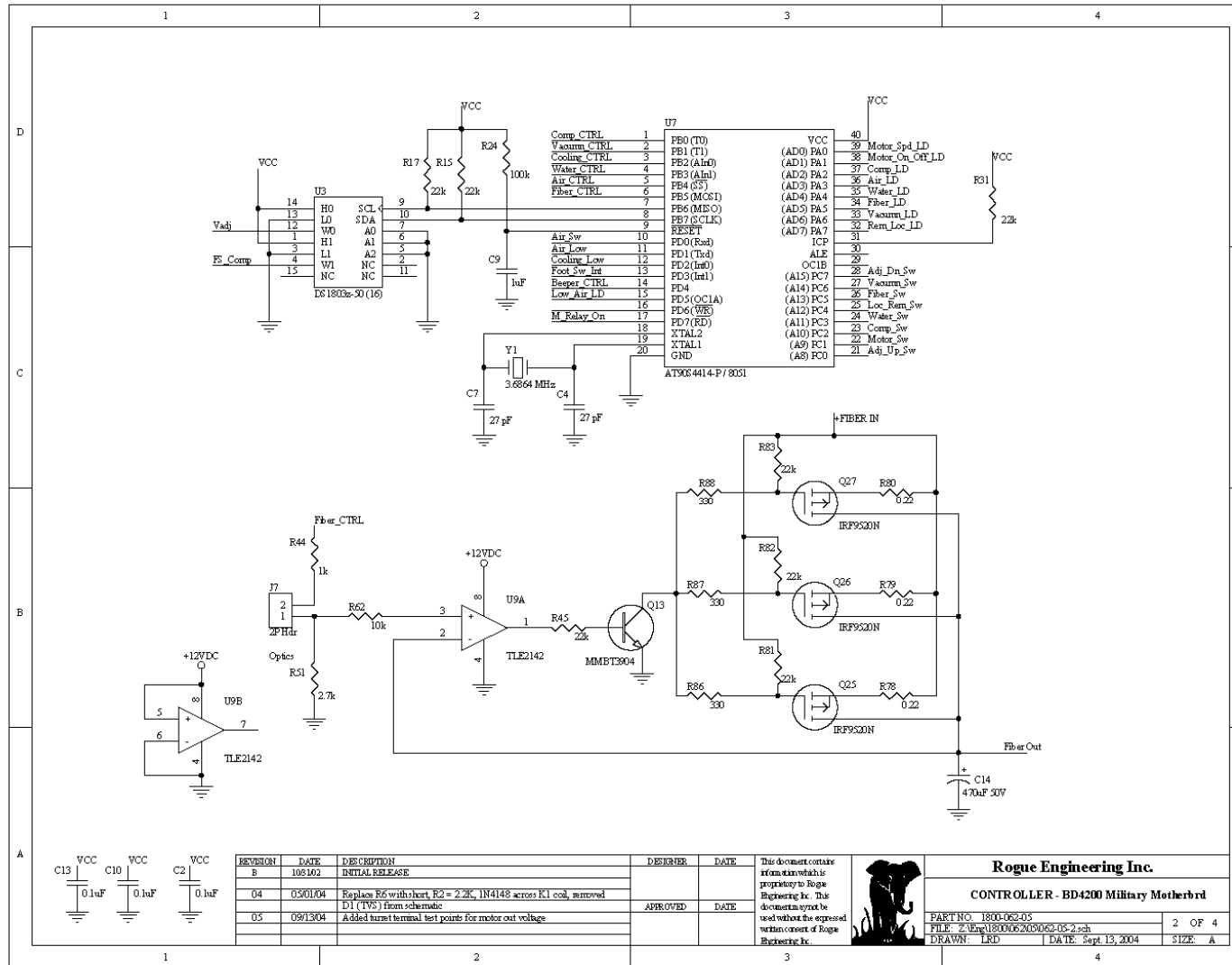

Main Circuit Board Schematics – Page 3

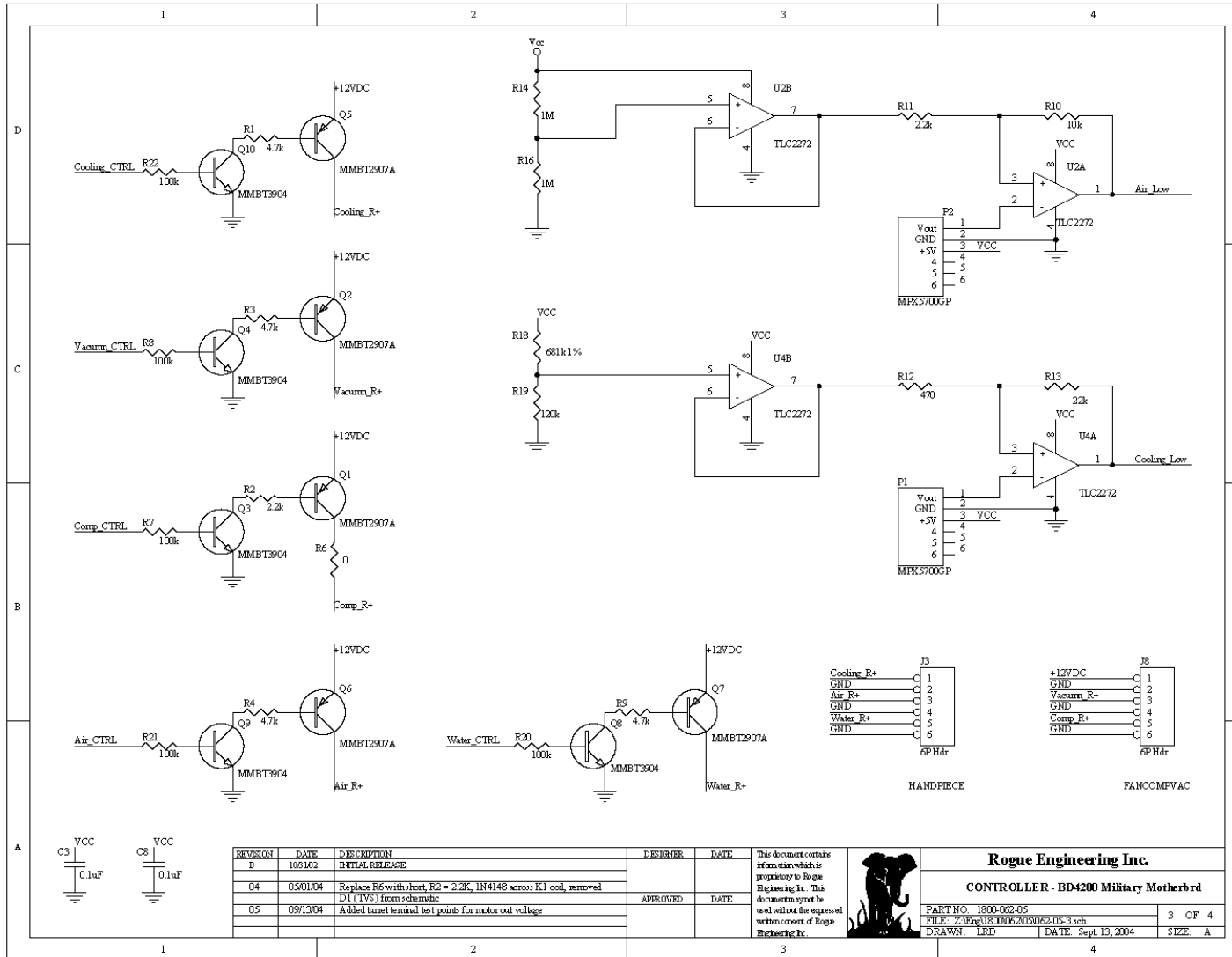

Main Circuit Board Schematics – Page 4

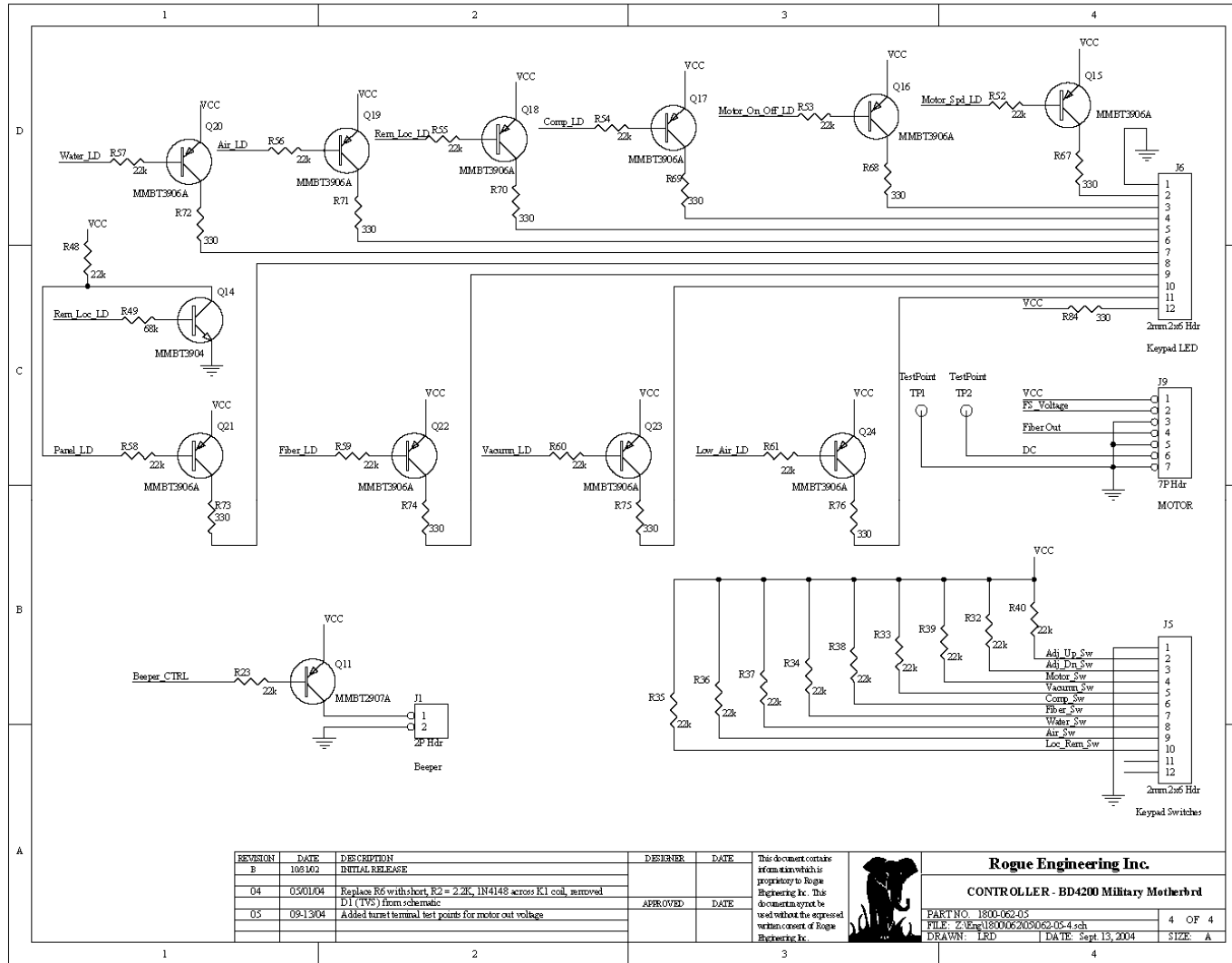

Main Circuit Board Layout

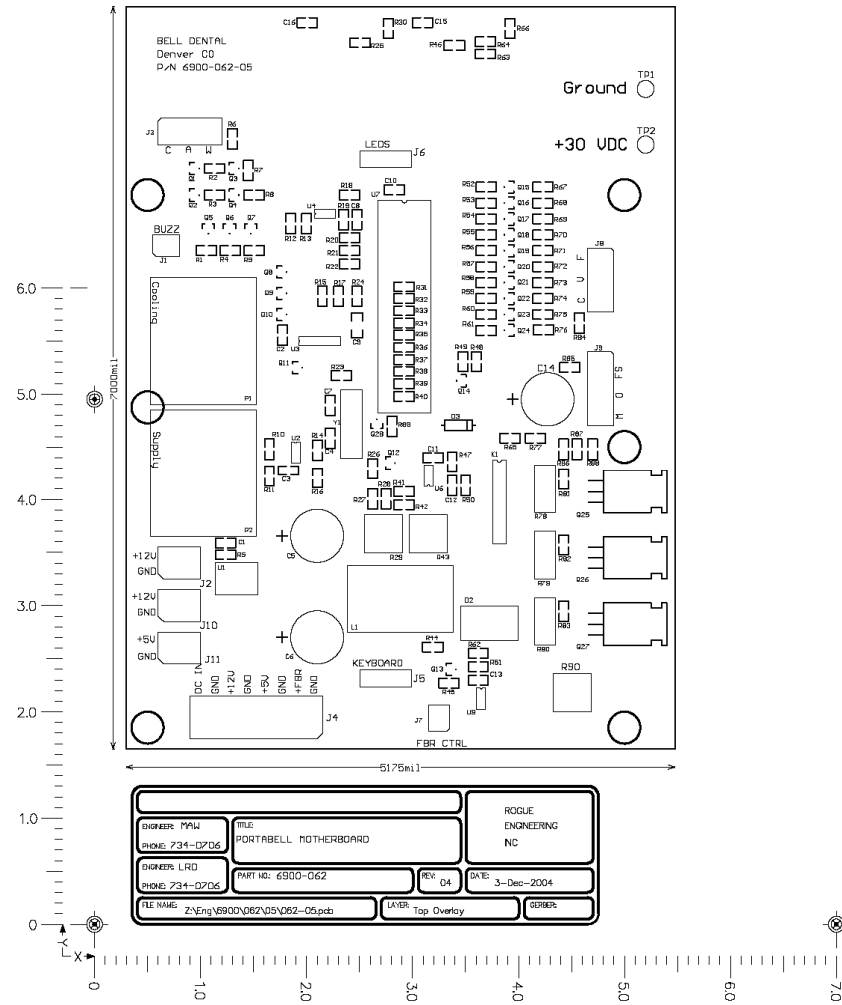

Main Circuit Board Parts List

Main Circuit Board Parts List

P/N	Title	Detail	Ref(m)
7510-008	Microcontroller integrated circuits	AVR AT90S8515 - 4 MHz	
0220-006	Potentiometer, PC Mount	20 kOhms 6mm Dustproof Cermet	R29,R43,R90
1110-005	Capacitor, Electrolytic (Radial)	470 uF 50 Volt	C5,C6,C14
0040-102	Resistor, Surface Mount 1/10W 5%	1 kOhm	R26,R44,R46,R64,R85,R98
0040-103	Resistor, Surface Mount 1/10W 5%	10 kOhm	R10,R62
0040-104	Resistor, Surface Mount 1/10W 5%	100 kOhms	R7,R8,R20,R21,R22,R24
0040-105	Resistor, Surface Mount 1/10W 5%	1 MOhm	R14,R16
0040-124	Resistor, Surface Mount 1/10W 5%	120 kOhms	R19
0040-162	Resistor, Surface Mount 1/10W 5%	1.6 kOhm	R42
0040-203	Resistor, Surface Mount 1/10W 5%	20 kOhm	R63
0040-222	Resistor, Surface Mount 1/10W 5%	2.2 kOhm	R2,R5,R11,R27,R66
0040-223	Resistor, Surface Mount 1/10W 5%	22 kOhms	R13,R15,R17,R23,R31,R32,R33,R34,R35,R36,R37, R38,R39,R40,R41R45,R48,R52,R53,R54,R55,R56, R57,R58,R59,R60,R61,R81,R82,R83
0040-272	Resistor, Surface Mount 1/10W 5%	2.7 kOhm	R51
0040-273	Resistor, Surface Mount 1/10W 5%	27 kOhm	R77
0040-331	Resistor, Surface Mount 1/10W 5%	330 Ohms	R67,R68,R69,R70,R71,R72,R73,R74,R75,R76,R84, R86,R87,R88
0040-471	Resistor, Surface Mount 1/10W 5%	470 Ohms	R12,R28
0040-472	Resistor, Surface Mount 1/10W 5%	4.7 kOhms	R1,R3,R4,R9,R30
0040-563	Resistor, Surface Mount 1/10W 5%	56 kOhm	R47,R49,R50,R65
0040-821	Resistor, Surface Mount 1/10W 5%	820 Ohm	R25
0050-6813	Resistor, Surface Mount 1/10W 1%	681 kOhm	R18
0070-002	Resistors, Surface Mount 1 W 5%	0.22 Ohms	R78,R79,R80
1050-104XR7	SM Ceramic capacitor 50 Volt 0805 Package	0.1 uF XR7 TC	C1,C2,C3,C8,C10,C11,C13,C15,C16
1050-270NPO	SM Ceramic capacitor 50 Volt 0805 Package	27 pF NPO TC	C4,C7
1050-472X7R	SM Ceramic capacitor 50 Volt 0805 Package	4700 pF	C12
1060-105XR7-16	SM Ceramic capacitor 16 Volt 1206 Package	1.0 uF XR7 TC 16V	C9

© 2006 Bell Dental Products, LLC. All rights reserved. No portion may be copied or reproduced without express written permission from Bell Dental Products, LLC.

1310-002	Crystal (Surface Mount)	3.6864 MHz 20 pF	Y1
6900-062-04	Printed Circuit Boards	PortaBell™ Motherboard PCB	

Main Circuit Board Parts List (continued)

P/N	Title	Detail	Ref(m)
7080-003	Rectifiers (Surface Mount)	30WQ06FN 3.5 Amp 60 Volt Schottky	D2
7190-001	Bipolar Small Signal Transistor (Surface Mount)	MMBT3904 NPN	Q3,Q4,Q8,Q9.Q10,Q13,Q14,Q28
7190-002	Bipolar Small Signal Transistor (Surface Mount)	MMBT3906 PNP	Q12,Q15,Q16,Q17,Q18,Q19,Q20,Q21,Q22,Q23,Q24
7190-003	Bipolar Small Signal Transistor (Surface Mount)	MMBT2907 PNP 500 mA	Q1,Q2,Q5,Q6,Q7,Q11
7280-003	Operational Amplifier (Surface Mount)	TLC2272CD 2 mA Dual	U2,U4
7280-006	Operational Amplifier (Surface mount)	Dual 44 Volt	U6,U9
7340-001	Digital to analog converters (SM)	DS1803Z-050 50 kOhm Dual Digital Pot	U3
2010-001	Inductor, Radial	107 uH 4.8 Amp	L1
3000-40	DIP Sockets	40 Pin Low Profile Open Frame Dual Leaf	U7
3040-016	PC Mount Male connector	.100 KK 2 Pin Straight Lk Hdr Gold	J1,J7
3040-017	PC Mount Male connector	.100 KK 6 Pin Straight Lk Hdr Gold	J3,J8
3040-020	PC Mount Male connector	.100 KK 7 Pin Straight Lk Hdr Gold	J9
3040-028	PC Mount Male connector	2 mm 6x2 Gold Header	J5,J6
3040-029	PC Mount Male connector	.156 KK 2 Pin RA Lk Hdr	J2,J10,J11
3040-032	PC Mount Male connector	.156 KK 8 Pin Straight Lk Hdr	J4
4040-009	Misc. Plastic Hardware	TO-220 Mica Insulators	
4060-002	Metal Screws	4-40 x 1/4" Zinc Plated Pan Head	
4060-009	Metal Screws	6-32 x 1/2" Zinc Plated Pan Head	
4070-002	Metal Nuts	4-40 Zinc Plated Hex Nut	
4070-004	Metal Nuts	6-32 Zinc Plated Hex Nut	
4140-001	Heat Sink	TO-220 24.4 C/W Thermal Resistance	
4560-003	Relay, Power	DPDT 2A 12V Relay P&B	K1
7180-001	MOSFET power transistors	IRF9520N P-Channel	Q25,Q26,Q27
7250-006	Voltage regulator (Through hole)	LT1076CT 2 A Adjustable Buck Regulator	U1
7370-004	Analog IC's (TH)	LM3914N LED Bar display driver	U5,U8
8020-010	LED	LED 10 Seg Bar Display (RED)	LED1,LED2
8100-001	Pressure Transducers	MPX5700GP 100 PSIG	P1,P2

© 2006 Bell Dental Products, LLC. All rights reserved. No portion may be copied or reproduced without express written permission from Bell Dental Products, LLC.

Keypad Circuit Board LEDs Schematic

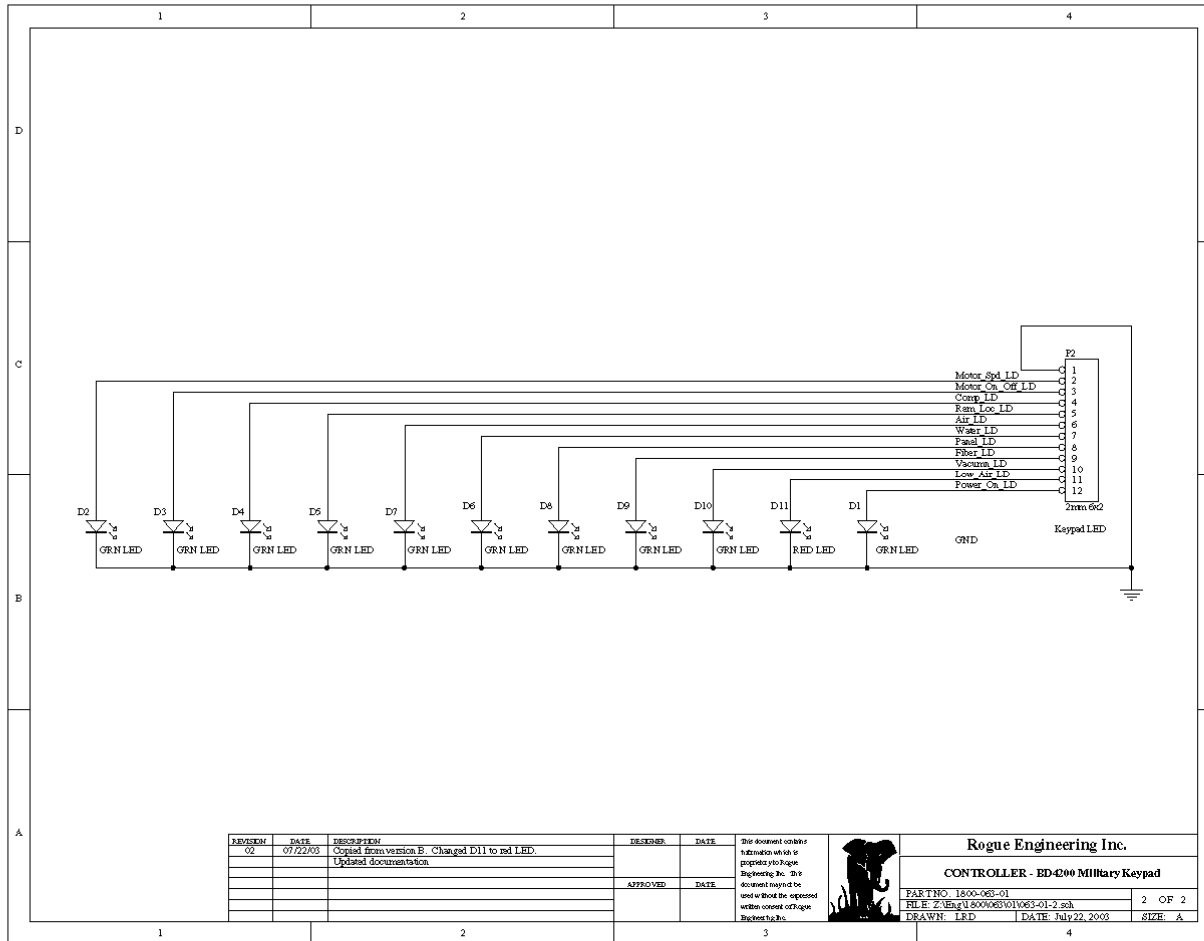

Keypad Circuit Board Buttons Schematic

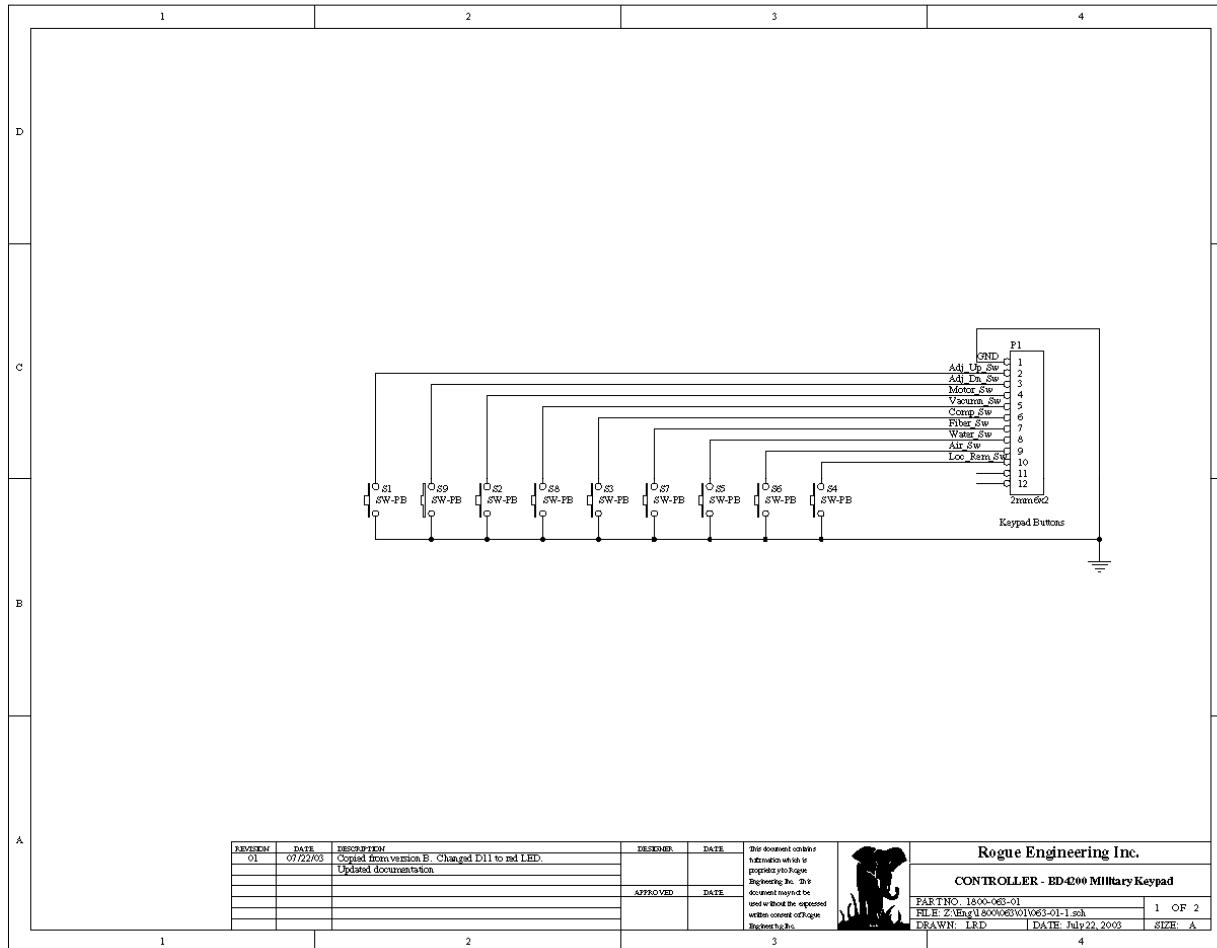

Keypad Circuit Board Parts List

Keypad Circuit Board Parts List

P/N	Title	Detail	Ref(m)
3050-004	PC Mount Female Connector	2 mm 6x2 socket	J1,2
4510-001	Dome switch	P35300 0.350" 300 gram tactile domes	S1-S9
6900-063-01	Printed Circuit Boards	PortaBell™ Keypad PCB	
8020-006	LED	LED Red Diffused - size T1	D11
8020-007	LED	LED Green Diffused - size T1	D1-D10

Voltage Control Circuit Board Schematic

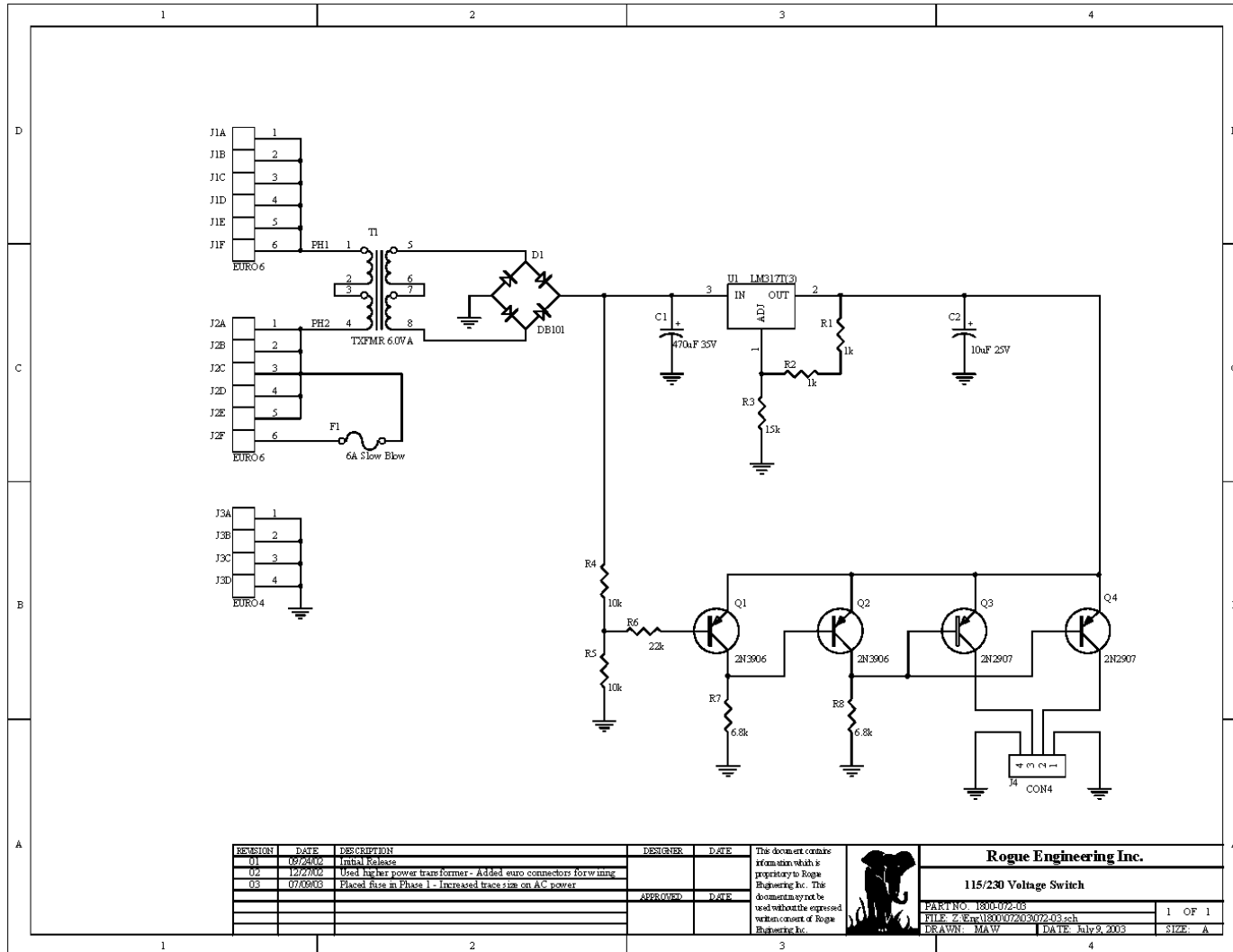

Voltage Control Circuit Board Layout

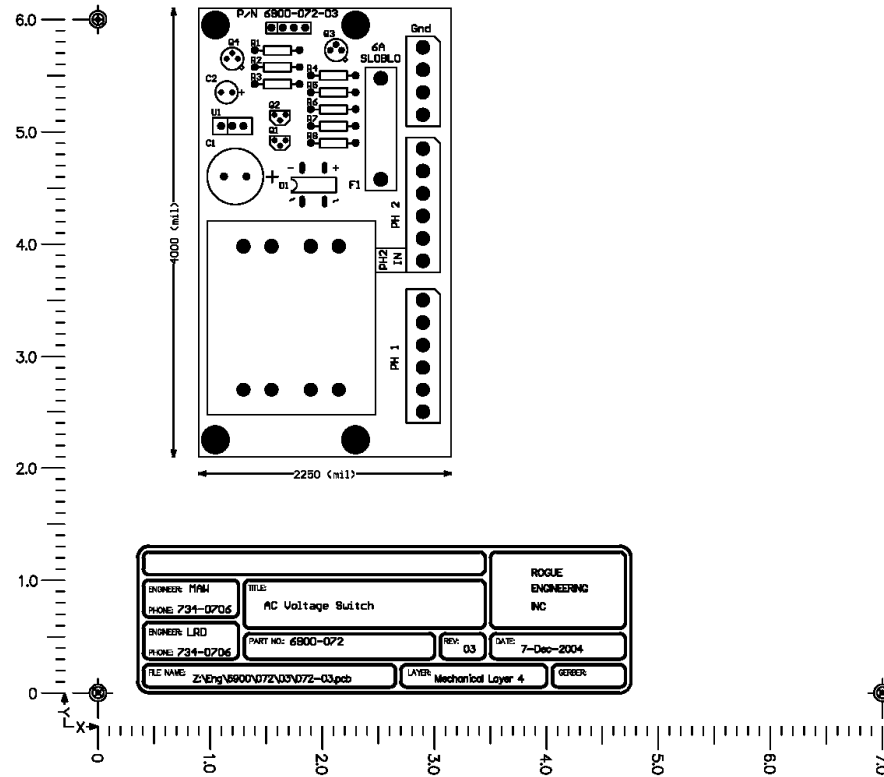

Voltage Control Circuit Board Parts List

Voltage Control Circuit Board

P/N	Title	Detail	Ref(m)
0000-102	Resistor, carbon 1/4w 5%	1 kOhms	R1,2
0000-103	Resistor, carbon 1/4w 5%	10 kOhms	R4,5
0000-153	Resistor, carbon 1/4w 5%	15 kOhms	R3
0000-223	Resistor, carbon 1/4w 5%	22 kOhms	R6
0000-682	Resistor, carbon 1/4w 5%	6.8 kOhms	R7,8
1110-003	Capacitor, Electrolytic (Radial)	10 uF 50 Volt 5x11 mm	C2
1110-005	Capacitor, Electrolytic (Radial)	470 uF 50 Volt	C1
2090-002	Power Transformer, PCB Mount	115/230 - 20 V 6 VA	T1
3024-003	Euro Style Wire Terminal Blocks Elevator Clamp	2 Position 5.0 mm Lead Spacing (Green)	J3
3024-004	Euro Style Wire Terminal Blocks Elevator Clamp	3 Position 5.0 mm Lead Spacing (Green)	J1,2
3040-021	PC Mount Male connector	.100 KK 4 Pin Straight Lk Hdr	J4
3150-002	Fuse clips	5mm x 20mm Snap-fit PCB Fuse clip	
3190-6.3SB	20 mm Fuses	6.3 Amp Slo-Blo	F1
6900-072-03	Printed Circuit Board	115/230 Voltage Switch	
7030-003	Bridge Rectifier (Through Hole)	DB101 1 Amp 50 Volt	D1
7150-001	Bipolar Small Signal Transistor (Thru Hole)	2N2907 PNP 500 mA	Q3,4
7150-003	Bipolar Small Signal Transistor (Thru Hole)	2N3906 PNP	Q1,2
7250-003	Voltage regulator (Through hole)	LM317T Adjustable 1.5 Amp	U1

APPENDIX C - Main Circuit Board Connector Test Point Values

J1 = BEEPER CONTROL - Not used

J2 = AUXILLARY I2V OUTPUT - Not Used

J3 = HANDPIECE CONNECTOR

- P1 = Cooling Relay +, when activated should measure +12V (+/- 0.5V)
- P2 = GND
- P3 = AIR Relay +, when activated should measure +12V (+/- 0.5V)
- P4 = GND
- P5 = Water Relay +, when activated should measure +12V (+/- 0.5V)
- P6 = GND

J4 = POWER SUPPLY INPUT

- P1 = GND
- P2 = Fiber Optic Light +, should measure +5V (+0.5/-1.5V)
- P3 = GND
- P4 = Jumpered to P2
- P5 = GND
- P6 = Relay Supply +, should measure +12V (+/- 0.5V)
- P7 = GND
- P8 = Handpiece Motor Supply +, should measure +38V (+/- 1.0V)

J5 = KEYPAD SWITCHES

- P1 = GND
- P2 = Motor Speed Increase Sw, should measure +5V when not activated
- P3 = Motor Speed Decrease Sw, should measure +5V when not activated
- P4 = Motor On Sw, should measure +5V when not activated
- P5 = Vacuum On Sw, should measure +5V when not activated
- P6 = Compressor On Sw, should measure +5V when not activated
- P7 = Fiber Optics On Sw, should measure +5V when not activated
- P8 = Handpiece Water On Sw, should measure +5V when not activated
- P9 = Handpiece Air On Sw, should measure +5V when not activated
- P10 = Panel/Footswitch Sw, should measure +5V when not activated
- P11 = Not Used
- P12 = Not Used

Note: the above switches read GND when activated

J6 = LED CONNECTOR

- P1 = GND
- P2 = Motor Speed LD, switched VCC with current limit
- P3 = Motor ON LD, switched VCC with current limit
- P4 = Compressor On LD, switched VCC with current limit
- P5 = Panel/Foot switch LD, switched VCC with current limit
- P6 = Handpiece Air On LD, switched VCC with current limit
- P7 = Handpiece Water On LD, switched VCC with current limit
- P8 = Panel LD, switched VCC with current limit
- P9 = Fiber Optic On LD, switched VCC with current limit
- P10 = Vacuum On LD, switched VCC with current limit
- P11 = Low Air Flow to Motor LD, switched VCC with current limit
- P12 = Power ON LD, VCC with current limit

Note: VCC is +5V, current limit resistor keeps voltage when active to 1.7V max.

J7 = FIBER OPTICS POTENTIOMETER

- P1 = Fiber Voltage Sense, (0 - 5V max)
- P2 = Fiber Voltage Supply, (0 - 5V max)

J8 = FAN COMPRESSOR VACUUM CONTROL

- P1 = Fan Supply +, + 12V (+/- 0.5V)
- P2 = GND
- P3 = Vacuum Pump Relay +, +12V when ON (+/- 0.5V), 0V when OFF
- P4 = GND
- P5 = Compressor Relay +, +12V when ON (+/- 0.5V), 0V when OFF
- P6 = GND

J9 = MOTOR CONTROL AND SUPPLY

- P1 = VCC, +5V (+/- 0.5V)
- P2 = Footswitch Supply, +5V (+/- 0.5V)
- P3 = GND
- P4 = Fiber Optic Supply, +3V (+/- 0.3V)
- P5 = GND
- P6 = Motor Supply, (0 - 30V)
- P7 = GND

J10 = AUXILARY 12V OUTPUT - Not Used

J11 = AUXILARY VCC OUTPUT - Not Used

© 2006 Bell Dental Products, LLC. All rights reserved. No portion may be copied or reproduced without express written permission from Bell Dental Products, LLC.

APPENDIX D - BIEN AIR ELECTRIC HANDPIECE MAINTENANCE

(There are additional instructions on the CD)

Dear Bien Air Customer:

Thank you for purchasing the Bien Air electric handpiece system. The following is the protocol to follow for maintaining your electric motor and handpiece attachments:

Handpiece Maintenance

1. Insert nozzle from the Spraynet 500, or Bio Lube™, Handpiece Cleaner can into the base of the hand piece. Spray for one second. This is a CLEANER ONLY. Use this product 1/week.
2. Reattach your handpiece to the motor with a bur fully seated in the head. Run the handpiece for 20-25 seconds while holding the handpiece head toward the floor
3. Repeat this process with white tube from the Lubrifluid®, or Bio Lube™, E-formula can. Lubrifluid® and Bio Lube™, E-formula are acceptable lubricants, and this must be used EVERY time prior to autoclaving.
4. Remove the handpiece from the motor and autoclave. Please see additional notes below.
 - a. Allow the autoclave to complete the drying cycle
 - b. If bagging handpiece do not seal bag
 - c. DO NOT use a chemiclave
5. Following autoclave cycle, allow ample cooling time prior to use.
6. During cooling process, allow handpiece to be placed with the head up to allow excess lubricant to drip from base prior to use. Do not cool handpieces with water. Allow ample time to cool.
7. Wipe handpiece down and DO NOT lubricate handpiece prior to use

Motor Maintenance

1. DO NOT autoclave the motor
2. DO NOT lubricate the motor. It is very important to not let any oil get inside the motor.
3. Tighten motor on to the tubing by removing sleeve from motor each time prior to use
4. Check carbon brushes every 6 months for possible. For replacement brushes contact Bell Dental Products at customerservice@belldental.com or 800-920-4478.
5. Consider changing o-rings and gasket annually.
6. Check cooling air to motor if you have an internally installed system with flow meter on a weekly basis (reading should = 10).

Please call Bien Air USA at 800-433-2436 for further questions.

© 2006 Bell Dental Products, LLC. All rights reserved. No portion may be copied or reproduced without express written permission from Bell Dental Products, LLC.

APPENDIX E - Sterilization and Maintenance Instructions For Motor and Hand Pieces

(These instructions are reproduced from the instruction booklet included with each motor and hand piece)

Clean, lubricate, and sterilize the hand piece and motor sheath before the treatment of each patient.

Cleaning and disinfection

Spray the inside and outside of the equipment to remove the residues. Use Spraynet 500 or Bio Lube™ Handpiece Cleaner. Further disinfectants based on one of the following:

- Phenolic alcohol
- Up to 3% glutaraldehydes
- Alcohols based on ethanol and methanol

Soak a clean cloth with the disinfectant and carefully clean the surfaces

Products NOT RECOMMENDED, disinfectants containing acetone, chlorine, and Javel water (sodium hypochlorite and water, normal bleach diluted one part bleach to 9 parts water).

Lubrication

Lubricate before each sterilization, and at least twice a day. Only use the Lubrifluid® or BioLube™, E-formula hand piece lubricant.

Place the instrument in a cloth so as to catch the debris and foreign matter expelled by the atomizer jet.

Remove the protective cap and insert the nozzle into the back of the instrument sleeve. Spray for about 1 second.

Use the wire cleaner supplied with each instrument to clean the spray tubes.

The device is supplied in “non-sterile” form. Before use, please follow the instructions under this heading.

- Steam autoclave up to 136°C/2.2 bars (277°F/32 PSI)
- Ethylene oxide at 60°C (140°F)

Important

- Drying cycle (postheat) max 136°C (277°F)

Important

DO NOT AUTOCLAVE THE MOTOR.
Only the outer sheath of the motor is autoclavable.

Important

After lubrication, always place the instrument with the head downwards in order to allow the lubricant to spread well through the whole mechanism and to prevent any infiltration of the oil into the micromotor when the instrument is attached to it.

APPENDIX F – Acceptance Test Record

**ACCEPTANCE TEST RECORD
PORTABELL™ III**

S/N:

Date:

TEST	FCN/VALUE	MEASUREMENT	PASS/REJ	TECH	COMMENTS
Ground/Continuity					P/S, Outlet, Filter, Transformer, CB studs, ground lug
Power-On LED Check	All LEDs ON				
Cooling Fan Operation	Blows Into Box				
Compressor Shuts-off	55-70 PSI				Adjust press regulator if needed
Compressor Turns-on	35-50 PSI				
Compressor Back Pressure Release	Operates				
Suction ON	Operates				
Proper Drill Rotation	Counter clockwise (Facing)				
Motor voltage	30volts min	W/FO: W/O FO:			First adjust circuit board Second adjust power supply
Fiber Optics ON	Operates				
Fiber Optic Intensity Adjust	Operates				
Fiber Optic Shut Off Delay	20-30 sec.				
Foot switch	Variable Operates				
Motor cooling air flow	9 li/min @ 50psi				
Motor Full Speed w/Fiber Optics On	Last LED On	Panel: Footsw:			Adjust CB pot if needed
Auto vacuum shut-off	Shuts off	Vacuum pump shuts off after 10-14 minutes w/motor OFF			

**ACCEPTANCE TEST RECORD
PORTABELL™ III (Continued)**

S/N:

Date:

TEST	FCN/VALUE	MEASUREMENT	PASS/REJ	TECH	COMMENTS
Motor Off	0 RPM				Adjust CB pot if needed
Motor Stopped	No LEDs on				
Motor Low Air Flow Shut-off	Motor shut-off	Panel: Footswitch:			
Motor Low Air Flow Shut-Off Override	Motor Turns ON	Panel: Footswitch:			
Hand Piece Air Flow ON	Operates with Motor				
Hand Piece Water Flow ON	Operates with Motor				
Syringe Air	Operates				
Syringe Water	Operates				
Syringe Air/Water	Operates				
Leak Check Water	No Leaks				
Drain water from system after test	Drained				
110 VAC Run In	Min 30 Minutes Continuous	Start time: End time:			Motor ON low, HP air and water ON with needle valves CLOSED
Auto Vacuum shut-off	10-14 min				
Air Retention	Pressure after 1 minute	<u>Time</u> 0 1 min			

**ACCEPTANCE TEST RECORD
PORTABELL™ III (Continued)**

S/N:

Date:

TEST	FCN/VALUE	MEASUREMENT	PASS/REJ	TECH	COMMENTS
220 VAC Burn In Cycle Comp/Vac. (6 hrs min)	All LED's ON				Op Time: Start: Stop:
Functional check	Fan ON				
Functional check	Motor operates				
Functional check	Fiber Optics ON				
Functional check	Compressor ON				
Functional check	Suction ON				
Functional check	HP Air ON				
Functional check	HP Water ON				
Functional check	Footswitch				
Functional check	Outlet 110VAC				
Air filters installed	Present				
Sound Insulating Foam installed	Present				
Top Seal installed	Present				
Cables, no interference					
Tubing, not hanging					
Latch closes tightly					
Compressor tie-down installed	Present				
Electrical cover installed	Present				