

Cardiocap™/5

Technical Reference Manual

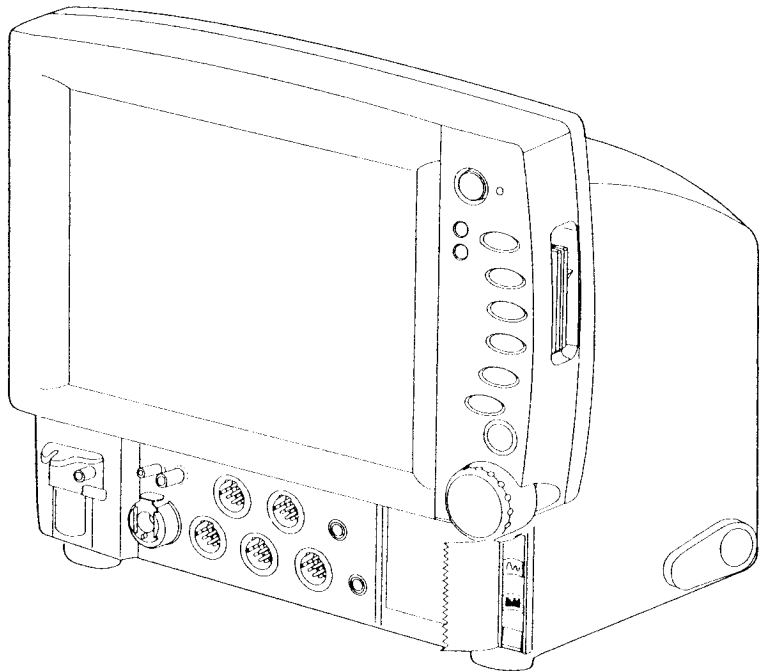

NOTICE

Intended use

The Datex-Ohmeda Cardiocap/5 and accessories are indicated for indoor monitoring of hemodynamic (ECG, impedance respiration, NIBP, temperature, SpO₂, and invasive pressure), respiratory (CO₂, O₂, N₂O, respiration rate, anesthetic agent, and agent identification), ventilatory (airway pressure, volume, and flow), and relaxation status (NMT) of all hospital patients.

With the N-XOSAT option, monitoring of arterial oxygen saturation includes monitoring hospital patients during conditions of clinical patient motion.

Cardiocap/5 is indicated for patients weighing 5 kg (11 lb.) or more.

Impedance respiration measurement is indicated for patients ages 3 years and older.

The monitor is indicated for use by qualified medical personnel only.

CAUTION: US Federal law restricts this device to sale by or on the order of a licensed medical practitioner. Outside the USA, check local laws for any restriction that may apply.

Classifications

IEC 60601-1:

- Type of protection against electric shock: Class I equipment.
- Degree of protection against electric shock (indicated by a symbol on the panel beside each connector): Type BF applied part or Type CF applied part.
- The equipment is not suitable for use in the presence of a flammable anesthetic mixture with air or with oxygen or nitrous oxide.
- Mode of operation: Continuous.

IEC 60529 (degree of protection against harmful ingress of water): IPX1

EU Medical Device Directive: IIb

Responsibility of the manufacturer

Datex-Ohmeda Division, Instrumentarium Corp. is responsible for the safety, reliability and performance of the equipment only if:

- Assembly, operation, extensions, readjustments, modifications, service, and repairs are carried out by personnel authorized by Datex-Ohmeda.
- Electrical installation complies with appropriate requirements.
- The equipment is used in accordance with the *Cardiocap/5 User's Guide* and serviced and maintained in accordance with the *Cardiocap/5 Technical Reference Manual*.

Datex-Ohmeda assumes no responsibility for the use or reliability of its software on equipment that is not furnished by Datex-Ohmeda.

Trademarks

Datex®, Ohmeda®, and other trademarks (Cardiocap/5, AS/3, CS/3, S/5, S/5 Light, D-lite, Pedi-lite, D-fend, D-fend+, MemCard, ComWheel, EarSat, FlexSat, OxyTip, Patient O₂, and Patient Spirometry) are the property of Instrumentarium Corp. or its subsidiaries.

Nellcor® is a registered trademark of Mallinckrodt Inc.

All other product and company names are the property of their respective owners.

© 2003 Datex-Ohmeda, Inc. All rights reserved.

Cardiocap/5 Technical Reference Manual

Part I – General Service Guide

Overview	1
Monitor Structure	
Safety Precautions	
Product Specifications	
Installation and Functional Check	2
Installation	
Interfacing	
Functional Check	
Functional Check Form	
Planned Maintenance	3
Planned Maintenance Instructions	
Planned Maintenance Form	
Troubleshooting	4
Messages	
Troubleshooting Charts	

Part II – Product Service Guide

Frames and Software	5
Hemodynamic Frame (F-MX)	
Hemodynamic with Airway Gases Frame (F-MXG)	
Anesthesia and Critical Care Software	
Measurement Parameters	6
Parameter Unit (NESTPR)	
Invasive Pressures and Second Temperature Option (N-XP)	
Nellcor Pulse Oximetry Option (N-XNSAT)	
Datex-Ohmeda Enhanced Pulse Oximetry Option (N-XOSAT)	
Airway Gas Options (N-XC, N-XCO, N-XCAiO)	
Patient Spirometry Option (N-XV)	
NeuroMuscular Transmission Option (N-XNMT)	
Service Procedures	7
Repair and Replacement	
Checks, Adjustments, and Calibration	
Service Menus	8
Spare Parts	9

Chapter 1. Overview

1.1 About this manual	1-1
Related documentation.....	1-1
1.2 Cardiocap/5 models and features.....	1-2
1.2.1 Options for hemodynamic model (F-MX).....	1-2
1.2.2 Options for hemodynamic model with airway gas measurement (F-MXG).....	1-2
1.2.3 Data collection and management options (for F-MX and F-MXG).....	1-2
1.3 Monitor structure.....	1-3
1.3.1 Measurement parameter units.....	1-3
NESTPR unit.....	1-3
PVX unit for Patient Spirometry (N-XV option).....	1-4
CAiO unit (N-XC, N-XCO, and N-XCAiO options).....	1-4
Datex-Ohmeda enhanced pulse oximetry (N-XOSAT option).....	1-4
Nellcor® compatible pulse oximetry (N-XNSAT option).....	1-4
NeuroMuscular Transmission (N-XNMT option).....	1-4
1.3.2 Communication	1-4
1.3.3 CPU board.....	1-4
Distributed processing.....	1-5
1.3.4 Display.....	1-5
1.3.5 I/O board	1-5
1.3.6 DC/DC board.....	1-5
1.3.7 AC/DC unit.....	1-5
1.3.8 Recorder (N-XREC option).....	1-5
1.4 Symbol definitions.....	1-6
Symbols on equipment	1-6
Symbols on screens	1-7
Symbols on transport packaging.....	1-7
1.5 Safety precautions	1-8
1.5.1 Warnings	1-8
Power connection.....	1-8
External connection.....	1-8
Electrical shock hazard.....	1-8
Fuse replacement.....	1-8
Explosion hazard.....	1-8
Patient safety.....	1-8
Temperature probes.....	1-8
Service and cleaning.....	1-9
1.5.2 Cautions.....	1-9
General.....	1-9
Installation.....	1-9
Before use.....	1-9
Airway gas measurement.....	1-9

Autoclaving, sterilizing, and cleaning	1-9
Service.....	1-9
Batteries.....	1-10
Special components and modifications	1-10
Storage and transport.....	1-10
Disposal.....	1-10
1.6 Specifications	1-11
1.6.1 F-MX and F-MXG frames.....	1-11
Power supply	1-11
Environmental conditions.....	1-11
Mechanics	1-11
LCD display.....	1-11
Battery	1-11
1.6.2 NIBP.....	1-11
1.6.3 Temperature	1-11
1.6.4 ECG	1-12
1.6.5 Impedance respiration	1-12
1.6.6 Pulse oximetry, standard	1-12
1.7 Specifications for options	1-13
1.7.1 Pulse oximetry, Datex-Ohmeda enhanced (N-XOSAT).....	1-13
1.7.2 Pulse oximetry, Nellcor compatible (N-XNSAT)	1-13
1.7.3 Invasive blood pressure (N-XP)	1-14
1.7.4 Airway gases (N-XC, N-XCO, and N-XCAiO).....	1-14
General.....	1-14
Respiration rate (RR).....	1-14
Carbon Dioxide (CO ₂), Oxygen (O ₂), and Nitrous Oxide (N ₂ O)	1-15
Anesthetic agents (AA)	1-15
Agent identification.....	1-15
MAC	1-15
Normal conditions.....	1-16
Conditions exceeding normal.....	1-16
1.7.5 Patient Spirometry (N-XV)	1-17
Conditions exceeding normal.....	1-18
1.7.6 NeuroMuscular Transmission (N-XNMT).....	1-18
NMT stimulation modes	1-18
Stimulator.....	1-18
Regional block mode.....	1-18
1.7.7 Recorder (N-XREC).....	1-18

Table of Figures

Figure 1-1. Cardiicap/5 monitor structure	1-3
---	-----

1. OVERVIEW

1.1 About this manual

The *Technical Reference Manual* is for use by service personnel who are qualified to perform service and maintenance procedures on the Datex-Ohmeda Cardiocap/5. The information in this manual is believed to be accurate and reliable, however, the manufacturer assumes no responsibility for its use.

The manual is organized as follows:

- Part I (chapter 1 – chapter 4) provides a general overview of the Cardiocap/5, including the information needed to install, checkout, and maintain the monitor. Part I also includes information for troubleshooting problems that may occur while using the monitor or that you may encounter while performing procedures in this manual, such as the Functional Check, for example.
- Part II (chapter 5 – chapter 9) contains detailed functional descriptions of the Cardiocap/5 hardware and software, including measurement principles and components for each measurement parameter. Procedures for replacing parts and making adjustments are also included. Part II also contains illustrations and detailed descriptions of all service screens used during checkout, maintenance, and other service-related activities. A list of parts with illustrations is located at the end of Part II.

Read the entire manual and make sure you understand the procedures described before installing, repairing, or adjusting the monitor. To avoid risks concerning safety or health, strictly observe all safety precautions.

Related documentation

For information about using the monitor, refer to the following:

Cardiocap/5 User's Guide, Anesthesia

Cardiocap/5 User's Guide, Critical Care

Cardiocap/5 User's Reference Manual, Anesthesia

Cardiocap/5 User's Reference Manual, Critical Care

For PCA drawings, circuit diagrams, and component lists, order the *PCA Drawings Service Kit*. See the *Spare Parts* chapter.

1.2 Cardiacap/5 models and features

The Datex-Ohmeda Cardiacap™/5 is a configured monitor that is intended for indoor monitoring of the hemodynamic, respiratory, relaxation, and ventilatory status of the patient. Two models of the monitor are available: hemodynamic (F-MX) and hemodynamic with airway gas measurement (F-MXG). Both models can be equipped with built-in options.

- All measurement parameter options (and the Recorder option, N-XREC) are factory-configured and cannot be added after purchase.
- Data collection and management options (N-XNET and N-XDNET) can be added later.

1.2.1 Options for hemodynamic model (F-MX)

The F-MX measures NIBP, ECG (3-lead and 5-lead), pulse oximetry (SpO₂), temperature (T1), and impedance respiration. The F-MX can be configured with the following built-in options:

N-XP	Two invasive pressure channels and second temperature (T2)
N-XREC	Recorder

The F-MX model can also be configured with **one** of the following built-in options:

N-XNSAT	Nellcor® compatible pulse oximetry (SpO ₂)
N-XOSAT	Datex-Ohmeda enhanced pulse oximetry (SpO ₂)

1.2.2 Options for hemodynamic model with airway gas measurement (F-MXG)

The F-MXG measures NIBP, ECG (3-lead and 5-lead), pulse oximetry (SpO₂), temperature (T1), impedance respiration, and airway gases. Gas measurement depends on which airway gas option is installed (N-XC, N-XCO, or N-XCAiO):

N-XC	Carbon Dioxide (CO ₂)
N-XCO	CO ₂ , N ₂ O, and Patient Oxygen (O ₂)
N-XCAiO	CO ₂ , anesthetic agents, agent identification, N ₂ O, and O ₂

The F-MXG can also be equipped with each of these built-in options:

N-XP	Two invasive pressure channels and second temperature (T2)
N-XV	Patient Spirometry (N-XCO or N-XCAiO option required)
N-XREC	Recorder

The F-MXG can also be configured with **one** of the following options:

N-XNSAT	Nellcor® compatible pulse oximetry (SpO ₂)
N-XOSAT	Datex-Ohmeda enhanced pulse oximetry (SpO ₂)
N-XNMT	NeuroMuscular Transmission (NMT) for relaxation measurement (N-XCAiO option required)

1.2.3 Data collection and management options (for F-MX and F-MXG)

For both models, these options can be factory-built or added later as upgrades:

N-XNET	Network
N-XDNET	Data card and Network

1.3 Monitor structure

The Cardiocap/5 can be equipped with several factory-configured options. The block diagram and descriptions that follow represent the maximum functionality of the monitor with all options installed.

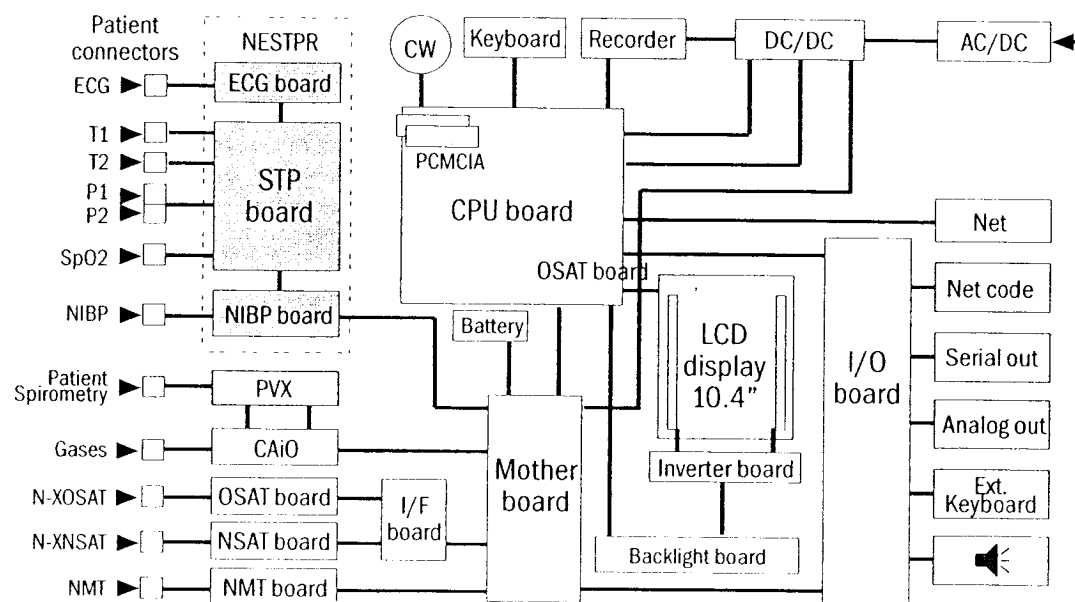

Figure 1-1. Cardiocap/5 monitor structure

The main software and measurement technologies are based on AS/3 hardware and software. Some parameter-measuring unit boards are interchangeable with AS/3 module boards, however, the units can not be replaced with the corresponding modules as the hardware of the assemblies is different.

1.3.1 Measurement parameter units

The maximum Cardiocap/5 parameter measurement configuration consists of the NESTPR, PVX, and CAiO units plus **ONE** of the following units: NMT or NSAT or OSAT.

The NESTPR, CAiO, and NMT units are connected to the CPU through the Mother board and communicate with the CPU over a standard AS/3 module bus. The NSAT or OSAT pulse oximetry unit is also connected to the CPU through the Mother board and communicates with the CPU over a standard AS/3 module bus, which is located on the SpO₂ interface board.

Each parameter measurement board contains a CPU that processes measurement data for the parameter(s) associated with that board before sending the data to the main CPU.

NESTPR unit

The NESTPR unit contains three boards for measuring hemodynamic parameters:

- The ECG board measures ECG (3-lead and 5-lead) and impedance respiration.
- The STP board measures oxygen saturation, temperature, and invasive blood pressure.
- The NIBP board measures noninvasive blood pressure.

PVX unit for Patient Spirometry (N-XV option)

The PVX unit connects to the CAiO unit and measures the patient's airway flow and pressure (Patient Spirometry).

CAiO unit (N-XC, N-XCO, and N-XCAiO options)

The CAiO unit measures airway gases. It is capable of measuring CO₂, N₂O, O₂, anesthetic agents (AA) and also identifying the present anesthetic agent.

Datex-Ohmeda enhanced pulse oximetry (N-XOSAT option)

The OSAT unit measures oxygen saturation and pulse rate using Datex-Ohmeda enhanced pulse oximetry technology.

Nellcor® compatible pulse oximetry (N-XNSAT option)

The NSAT unit measures oxygen saturation and pulse rate using signal processing electronics and software that are based on Nellcor stand-alone oximeters.

NeuroMuscular Transmission (N-XNMT option)

The NMT unit measures the relaxation status (TOF, DBS, and ST) of patients. When used with a regional block cable, the unit acts as a nerve locator.

1.3.2 Communication

The CPU communicates with the hemodynamic parameters measuring unit (NESTPR) and airway gas measuring unit (CAiO) over a standard AS/3 module bus. It is based on the widely-used industry standard RS485, which uses a differential serial method to transfer data and is quite robust.

RS485 serial communication supports multidrop or party line connections. This means all units connected to the module bus use the same two physical wires for communication purposes. The module bus uses a 500 kbps data transfer rate.

Communication with the I/O board and the DC/DC board takes place over an internal synchronous serial bus. The same bus also controls display brightness and audio signals by means of D/A converters located on the CPU board.

Communication with the Net takes place over a separate synchronous serial channel.

Communication with the Recorder takes place over an asynchronous serial channel.

1.3.3 CPU board

The control functions of the monitor are centralized on the CPU board. The CPU:

- Controls the power on/off sequencing.
- Controls the brightness of the LCD screen by means of the Backlight board.
- Controls the Inverter board that provides the high voltage for the display backlights.
- Reads input from the keyboard and ComWheel.
- Controls the serial channels and I/O functions of the monitor.

Two PCMCIA-compatible data card slots on the board are for loading software and transferring data.

Distributed processing

The parameter and airway measuring units contain their own microprocessor systems for performing low level functions, such as waveform filtering and pneumatics control. At the same time, the main CPU performs higher level tasks (trending and alarm control, for example).

1.3.4 Display

The main CPU directly controls the monitor display, a 10.4 inch color LCD. Supply voltages for the display are connected via the CPU board and the Backlight board. The Inverter board provides high voltage for the display backlights. The CPU controls the display brightness by adjusting the backlight voltage.

1.3.5 I/O board

The I/O board contains D/A converters for analog outputs and the audio output amplifier. It also contains connectors for the network identification plug, serial I/O, analog output, and external keyboard.

Analog outputs are created by transferring digital data from the CPU to the D/A converters on the I/O board through the internal synchronous serial bus. The network identification plug is connected to the CPU over a separate synchronous serial channel.

1.3.6 DC/DC board

The DC/DC board converts 15 VDC coming from the AC/DC unit to different supply voltages for the monitor. All outputs are short-circuit and over-voltage protected. The CPU controls the output voltages. If the mains voltage drops, the 12 VDC back-up battery automatically supplies power to the monitor. The battery will run the monitor for at least 15 minutes. The battery is always charged when mains voltage is connected. The temperature sensor that measures the monitor's internal temperature is located on the board. The DC/DC board communicates with the CPU over the internal synchronous serial bus.

1.3.7 AC/DC unit

The AC/DC unit converts the mains voltage to 15 VDC that is fed to the DC/DC board. The input voltage range of the unit is 100 to 240 VAC. The DC/DC board shuts down the AC/DC unit when there is over voltage detected on the 15 VDC output. The shutdown mode is reset by detaching the mains power cord for 30 seconds.

1.3.8 Recorder (N-XREC option)

The Recorder prints trend data and record parameter waveforms. It connects to the CPU through an asynchronous serial channel. Recorder supply voltages connect through a Recorder board that is permanently attached to the recorder mounting box. The board contains a voltage filter and a delay circuit for 12 V.

1.4 Symbol definitions

Symbols on equipment



Attention! Read accompanying instructions, including all warnings and cautions, before using this device.

This symbol has the following meanings when it appears on the screen:

- When displayed beside the O₂ value, indicates that the FiO₂ low-alarm limit is set below 21%.
- When displayed next to the HR value, indicates that there is a risk that the monitor counts pacemaker spikes (pacer is set ON R) or the monitor counts T-waves (a wide QRS is selected).



Type BF applied part (IEC 60601-1). Defibrillator-proof protection against electric shock.



Type CF applied part (IEC 60601-1). Defibrillator-proof protection against electric shock.



Main Menu. Located beside the ComWheel to indicate you can open the Main Menu by pressing the ComWheel when no other menu is displayed.



Power On/Standby.



Pb

This battery contains lead. Separate from other waste for disposal according to local regulations.



Pb

This battery contains lead and can be recycled.



Dangerous voltage.



Gas outlet (in airway gas models only).



Ethernet connectors.



Equipotentiality. Monitor can be connected to potential equalization conductor.





Alternating current.





Fuse.

Symbols on screens

- 

When displayed on the upper left corner of the screen, indicates alarms are silenced. When in the menu or digit fields, indicates that the alarm source has been turned off.
- 

Sub menu. Selecting an alternative with this symbol in a menu opens a new menu.
- 

The monitor is connected to the Datex-Ohmeda Network.
- 

Data card (green) and/or Menu card (white) is inserted.
- 

Indicates the beats detected.
- 

Respiration rate is measured using impedance respiration measurement.
- 

Back-up battery operation and remaining capacity.
- 

Back-up battery charging.

Symbols on transport packaging

- 

The contents of the package are fragile and have to be handled with care.
- 

Indicates the correct upright position of the transport package.
- 

The package must be kept in a dry environment.
- 

The package should be kept within the indicated temperature limitations.

1.5 Safety precautions

1.5.1 Warnings

Refer to the *User's Reference Manual* for additional warnings to be observed while monitoring a patient.

A WARNING indicates a situation in which the user or the patient may be in danger of injury or death.

Power connection

Before connecting the power cord to the mains outlet, check that the local voltage and frequency rating corresponds with the rating stated on the device plate on the rear panel of the monitor.

Connect the monitor to a three-wire, grounded, hospital-grade receptacle. Do not remove the grounding prong from the power plug.

Use an intact power cord. Replace the cord if it is cracked, frayed, broken, or damaged.

Do not apply tension to the power cord. The cord may break.

Do not use extension cords or adapters.

External connection

Connect the monitor only to other monitors or external devices specified by Datex-Ohmeda.

Electrical shock hazard

When you connect equipment to the Cardiicap/5 input and output connectors, you are configuring a medical system and are responsible for ensuring that the system complies with IEC/EN 60601-1-1 and with local requirements.

Do not touch any exposed wire or conductive surface while covers are off and the monitor is energized. The voltages present can cause injury or death.

Always perform an electrical safety check and leakage current test of the monitor after service.

Fuse replacement

Replace the fuse with a fuse of the same type and with the same rating.

Explosion hazard

Do not use the monitor in the presence of flammable anesthetics.

Patient safety

Do not test or perform maintenance on the monitor while it is being used on a patient.

Use only cables and accessories approved by Datex-Ohmeda. Do not modify them. Other cables and accessories may damage the monitor or interfere with measurement.

PACEMAKER PATIENTS: The impedance respiration measurement may cause rate changes in Minute Ventilation Rate Responsive Pacemakers. Set the pacemaker rate responsive mode off or turn the impedance respiration measurement off on the monitor.

Temperature probes

To prevent injury, use Datex-Ohmeda temperature probes only.

Service and cleaning

Only trained personnel with proper tools and test equipment should perform the tests and repairs described in this manual. Unauthorized service may void the monitor warranty.

Turn off the power and unplug the power cord before cleaning or service. Make sure the monitor is completely dry before reconnecting it to the mains outlet.

1.5.2 Cautions

Refer to the *User's Reference Manual* for additional cautions to be observed while monitoring a patient.

A **CAUTION** indicates a condition that may lead to equipment damage or malfunction.

General

US Federal law restricts this device to sale by or on the order of a licensed medical practitioner.

Do not apply pressurized air to any outlet or tubing connected to the monitor. Pressure may destroy sensitive elements.

Use only cables and accessories approved by Datex-Ohmeda. Other cables and accessories may damage the system or interfere with measurement.

Vibrations during transport may disturb SpO₂, ECG, impedance respiration, and NIBP measurements.

Installation

Leave space behind the monitor to allow proper ventilation.

Before use

Allow two minutes for warm-up and note any error messages or deviations from normal operation.

Airway gas measurement

Strong scavenging suction may change the operating pressure of the monitor and cause inaccurate readings or internal damage.

Autoclaving, sterilizing, and cleaning

Do not steam autoclave or gas sterilize the monitor.

Do not use hypochlorite, ammonia-based, phenol-based, or acetone-based cleaners. These cleaners may damage the surface of the monitor.

Do not immerse any part of the monitor in liquid or allow liquid to enter the interior.

Clean the fan dust filter on the rear panel once a month or whenever necessary.

Service

Electrostatic discharge through the PC boards may damage the components. Before handling printed circuit boards, wear a static control wrist strap. Handle all boards by their nonconductive edges and use antistatic containers when transporting them.

Do not break or bypass the patient isolation barrier when testing PC boards.

Batteries

There is a lithium battery on the CPU board. Discard broken IC containing the battery according to local regulations.

The battery package of the power supply unit in this device contains lead, which is hazardous to the environment. Dispose of the battery according to local regulations.

To replace the batteries safely, please refer to the instructions in this manual.

- Do not short-circuit the battery terminals. Short-circuiting the battery may produce a very high current, which damages the battery and may cause injury to personnel.
- Do not dispose of the battery into open flame, nor put the battery near fire, as it may explode.
- Do not disassemble the battery. It contains electrolyte, which may damage clothing or cause injury to skin or eyes. If exposed to electrolyte, wash the injured area with plenty of water and contact a doctor.

See *Symbols on equipment* earlier in this chapter.

Special components and modifications

Special components used in this monitor are vital to assure reliability and safety. Datex-Ohmeda assumes no responsibility for damage if replacement components not approved by Datex-Ohmeda are used.

The manufacturer accepts no responsibility for modifications made to the monitor outside the factory.

Storage and transport

Do not store or transport the monitor outside the specified temperature and pressure range:

Temperature	-10 to +50 °C (14 to 122°F)
Ambient pressure	660 to 1060 hPa (500 to 800 mmHg)
	660 to 1060 mbar
Relative humidity	0 to 85 % non-condensing

Disposal

Dispose of the device and its parts according to local environmental and waste disposal regulations.

1.6 Specifications

All product specifications are subject to change without prior notice.

1.6.1 F-MX and F-MXG frames

Power supply

Rated voltages and frequencies: 100 to 240 VAC 60/50 Hz

Allowed voltage fluctuations: $\pm 10\%$

Maximum power consumption: 80 VA

Fuses (2): T2AH/250V

Environmental conditions

Operating temperature: $+10$ to $+40$ °C (50 to 104 °F)

Storage and transport temp: -10 to $+50$ °C (14 to 122 °F)

Relative humidity: 10 to 85 % noncondensing, in airway 0 to 100 % condensing

Atmospheric pressure: 660 to 1060 hPa (500 to 800 mmHg)

Mechanics

Dimension: 330 mm \times 220 mm \times 300 mm (width \times depth \times height)

Weight: <11.2 kg / <24.8 lbs (F-MXG with all options); <10.2 kg / <22.6 lbs (F-MX with all options)

LCD display

Display size: 10.4 inch

Display type: Active matrix color LCD display

Resolution: 640 \times 480

Battery

Type: 12V 2.6AH, lead acid

Back-up battery time: at least 15 minutes when fully charged

Charging time: 5 hours (typical)

The green battery charge status LED is On when the battery is fully charged, on the holding voltage. The LED flashes when the battery is being charged.

1.6.2 NIBP

Measurement range:

adult 25 to 260 mmHg

child 25 to 195 mmHg

infant 15 to 145 mmHg

Pulse rate range accepted: 30 to 250 bpm

Typical measuring time: adults 23 seconds, infants 20 seconds

1.6.3 Temperature

Measurement range: 10 to 45 °C (50 to 113 °F)

Measurement accuracy: 25 to 45.0 °C ± 0.1 °C (77 to 113 °F ± 0.2 °F)

10 to 24.9 °C ± 0.2 °C (50 to 76.8 °F ± 0.4 °F)

Probe type: Compatible with Datex-Ohmeda temperature probes only

1.6.4 ECG

Waveform display (with 50 Hz power supply frequency):

Monitoring filter: 0.5 to 30 Hz

ST filter: 0.05 to 30Hz

Diagnostic filter: 0.05 to 100 Hz

Waveform display (with 60 Hz power supply frequency):

Monitoring filter: 0.5 to 40 H

ST filter: 0.05 to 40 Hz

Diagnostic filter: 0.05 to 100 Hz

Heart rate

Measurement range: 30 to 250 bpm

Measurement accuracy: $\pm 5\%$ or ± 5

Pacemaker pulse detection level: 2 to 500 mV

Pacemaker pulse duration: 0.5 to 2 ms

1.6.5 Impedance respiration

Respiration range: 4 to 120 respirations/minute

Accuracy: $\pm 5\%$ or ± 5 bpm

1.6.6 Pulse oximetry, standard

Display update time: 5 seconds

Averaging time: adjustable

Plethysmographic waveform scaling: adjustable

SpO₂

Calibration range: 50 to 100%

Calibrated against functional saturation

Measurement range: 40 to 100%

Measurement accuracy (% SpO₂ ± 1 SD):

80 to 100% ± 2 digits;

50 to 80% ± 3 digits;

Below 50% unspecified

NOTE: SpO₂ measurement accuracy is based on deep hypoxia studies using Datex-Ohmeda FingerSat sensors on volunteered subjects. Arterial blood samples were analyzed by a Radiometer OSM CO-oximeter. Refer to the sensor instructions for specific SpO₂ accuracy data.

Pulse rate

Measurement range: 30 to 250 bpm

Measurement accuracy: $\pm 5\%$ or ± 5 bpm

Default alarm limits

SpO₂: high Off, low 90%

Pulse rate: high 160, low 40

NOTE: Limits are adjustable.

Sensor emitter wavelength ranges

Red LED: 660 nm

Infrared LED: 900 nm

1.7 Specifications for options

1.7.1 Pulse oximetry, Datex-Ohmeda enhanced (N-XOSAT)

Display update time: 5 seconds

Averaging time: 12 seconds

Plethysmographic waveform scaling: automatic

SpO₂

Calibration range: 70 to 100%

Calibrated against functional saturation

Measurement range: 1 to 100%

Measurement accuracy (% SpO₂ ± 1 SD):

70 to 100% ± 2 digits

70 to 100% ± 3 digits during conditions of clinical patient motion

Below 70% unspecified

NOTE: SpO₂ measurement accuracy is statistically derived and correlated to simultaneous arterial blood gases measured on a Radiometer OSM3 CO-oximeter. Refer to the sensor instructions for specific accuracy data.

Pulse rate

Measurement range: 30 to 250 bpm

Measurement accuracy: ± 2% or ± 2 bpm (whichever is greater)

Default alarm limits

SpO₂: high Off, low 90%

Pulse rate: high 160, low 40

NOTE: Limits are adjustable.

Sensor emitter wavelength ranges

Red LED: 650 to 665 nm

Infrared LED: 930 to 950 nm

Average power: ≤ 1 mW

1.7.2 Pulse oximetry, Nellcor compatible (N-XNSAT)

Display update time: 5 seconds

Averaging time: 5 to 7 seconds

Plethysmographic waveform scaling: automatic

SpO₂

Calibrated against functional saturation

Measurement range: 1 to 100%

Measurement accuracy (% SpO₂ ± 1 SD):

70 to 100% (± 2 digits to ± 3.5 digits, depending on the sensor)

Below 70% unspecified

See the *User's Reference Manual (Pulse Oximetry chapter)* for a list of approved sensors and accuracy details.

NOTE: SpO₂ measurement accuracy is based on testing healthy adult volunteers in induced hypoxia studies.

Pulse rate

Measurement range: 30 to 250 bpm

Measurement accuracy: ± 3 digits

Default alarm limits

SpO₂: high Off, low 90%

Pulse rate: high 160, low 40

NOTE: Limits are adjustable.

Sensor emitter wavelength ranges

Red LED: 660 nm

Infrared LED: 920 nm

1.7.3 Invasive blood pressure (N-XP)

Measurement range: -40 to 320 mmHg

Measurement accuracy: $\pm 5\%$ or ± 2 mmHg

Transducer sensitivity: 5 μ V/V/mmHg, 5 Vdc, max 20 mA

Pulse rate

Measurement range: 30 to 250 bpm

Accuracy: $\pm 5\%$ or ± 5 bpm

1.7.4 Airway gases (N-XC, N-XCO, and N-XCAiO)

Accuracy specifications apply in normal conditions.

General

Airway humidity: 0 to 100%, condensing

Sampling rate: 200 \pm 20 ml/min. (sampling line 2-3 m, normal conditions)

Sampling delay: 2.5 seconds typical with a 3 m sampling line

Total system response time: 2.9 seconds typical with a 3 m sampling line, including sampling delay and rise time

Display update rate: breath-by-breath

Automatic compensation for pressure, CO₂-N₂O and CO₂-O₂ collision broadening effect

Warm-up time:

2 minutes for operation with CO₂, O₂, and N₂O

5 minutes for operation of anesthetic agents

30 minutes for full specifications

Autozeroing interval:

immediately after "Calibrating gas sensor" message and

2, 5, 10, 15, 30, 45, 60 minutes after start-up, then every 60 minutes

Respiration rate (RR)

Measurement range: 4 to 60 breaths/minute

Detection criteria: 1 % variation in CO₂

Carbon Dioxide (CO₂), Oxygen (O₂), and Nitrous Oxide (N₂O)

Measurement	Carbon Dioxide (CO ₂)	Oxygen (O ₂)	Nitrous Oxide (N ₂ O)
Range	0 to 15 vol%, (0 to 15 kPa) (0 to 113 mmHg)	0 to 100%	0 to 100%
Rise time	< 400 ms typical	< 400 ms typical	< 450 ms typical
Accuracy (typical value)	≤ 0.3 vol%	≤ 2 vol%	≤ 3 vol%
Gas cross effects	< 0.2 vol% (O ₂ , N ₂ O, and anesthetic agents)	< 1 vol% (anesthetic agents); < 2 vol% (N ₂ O)	< 2 vol% (anesthetic agents)

NOTE:

- If CO₂ concentration is below 0.1%, 0.0% is displayed.
- O₂ Fi-Et difference: resolution 0.1 vol%

Anesthetic agents (AA)

Resolution is two digits when the AA concentration is below 1.0 vol%.

If AA concentration is below 0.1 vol%, 0.0% is displayed.

Measurement	Halothane, Isoflurane, Enflurane	Sevoflurane	Desflurane
Range	0 to 6%	0 to 8%	0 to 20%
Rise time	< 400 ms typical		
Accuracy (typical value)	≤ 0.2 vol%	≤ 0.2 vol%	0 to 5% ≤ 0.2 vol% 5 to 10% ≤ 0.5 vol% 10 to 20% ≤ 1.0 vol%
Gas cross effects	< 0.15 vol% N ₂ O		

Agent identification

Identification threshold: 0.15 vol% typically

Identification time: < 20 seconds (for pure agents)

Mixture identification threshold for 2nd agent: 0.2 vol% + 10% of total conc.

MAC

Range: 0 to 9.9 MAC

Equation:

$$\text{MAC(AA)} = \frac{\%(\text{ETAA})}{x(\text{AA})} + \frac{\% \text{ETN}_2\text{O}}{100}$$

where x(AA): Hal = 0.75%, Enf = 1.7%, Iso = 1.15%, Sev = 2.05%, Des = 6.0%.

Normal conditions

After 30-minute warm-up period:

Ambient temperature: 18 to 28 °C, within ± 5 °C of calibration

Ambient pressure: 500 to 800 mmHg, ± 50 mmHg of calibration

Ambient humidity: 20 to 80% RH, ± 20% RH of calibration

Non-disturbing gases:

Ethanol C₂H₅OH (< 0.3%)

Acetone (< 0.1%)

Methane CH₄ (< 0.2%)

Nitrogen N₂

Carbon monoxide CO

Nitric oxide NO (< 200 ppm)

Water vapor

Maximum effect on readings:

CO₂ < 0.2 vol%

O₂, N₂O < 2 vol%

Anesthetic agents < 0.15 vol%

Effect of helium: decreases CO₂ readings < 0.6 vol% typically

Conditions exceeding normal

Accuracy specifications under conditions ❶ ❷ ❸:

- ❶ Ambient temperature: 10 to 40 °C, within ± 5 °C of calibration
 Ambient pressure: 500 to 800 mmHg, ± 50 mmHg of calibration
 Ambient humidity: 10 to 98% RH, ± 20% RH of calibration
- ❷ During warm-up, 2 to 10 minutes (anesthetic agents 5-10 minutes) under normal conditions
- ❸ During warm-up, 10 to 30 minutes under normal conditions

Parameter	Accuracy under Condition ❶
CO ₂	± (0.3 vol% + 4% of reading); at 5 vol% error ± 0.5 vol%
O ₂	± (2 vol% + 2% of reading)
N ₂ O	± (3 vol% + 3% of reading)
Agents (Des, Enf, Hal, Iso, Sev)	± (0.2 vol% + 10% of reading)

Parameter	Accuracy under Condition ❷
CO ₂	± (0.4 vol% + 7% of reading); at 5 vol% error ± 0.75 vol%
O ₂	± (3 vol% + 3% of reading)
N ₂ O	± (3 vol% + 5% of reading)
Agents (Des, Enf, Hal, Iso, Sev)	± (0.3 vol% + 10% of reading)

Parameter	Accuracy under Condition ③
CO ₂	± (0.3 vol% + 4% of reading); at 5 vol% error ± 0.5 vol%
O ₂	± (2 vol% + 2% of reading)
N ₂ O	± (3 vol% + 3% of reading)
Agents (Des, Enf, Hal, Iso, Sev)	± (0.2 vol% + 10% of reading)

1.7.5 Patient Spirometry (N-XV)

Accuracy specifications apply in normal conditions.

After 10-minute warm-up period

Ambient temperature: 10 to 40 °C

Ambient pressure: 500 to 800 mmHg

Ambient humidity: 10 to 98% RH

Airway humidity: 10 to 100% RH

Respiration rate: 4 to 35 breaths/minute (adult); 4 to 50 breaths/minute (pediatric)

I:E ratio: 1:4.5 to 2:1

Intubation tube: 5.5 to 10 mm (adult); 3 to 6 mm (pediatric)

Detection through D-lite™ or Pedi-lite™ flow sensor and gas sampler:

Measurement	D-lite flow sensor (adult)	Pedi-lite flow sensor (pediatric)
Tidal volume		
Measurement range	150 to 2000 ml	15 to 300 ml
Resolution	1 ml	1 ml
Accuracy (typical value)	± 6% or 30 ml	± 6% or 4 ml
Minute volume		
Measurement range	2 to 20 l/minute	0.5 to 5 l/minute
Resolution	0.1 l/minute	0.1 l/minute
Accuracy (typical value)	± 6%	± 6%
Airway pressures		
Measurement range	-20 to +100 cmH ₂ O	-20 to +100 cmH ₂ O
Resolution	0.5 cmH ₂ O	0.5 cmH ₂ O
Accuracy (typical value)	± 1 cmH ₂ O	<i>not applicable</i>
Airway flow		
Measurement range	1.5 to 100 l/minute	0.25 to 25 l/minute
Compliance		
Measurement range	4 to 100 ml/cmH ₂ O	4 to 100 ml/cmH ₂ O
Resolution	1 ml/cmH ₂ O	0.1 ml/cmH ₂ O
Airway resistance		
Measurement range	0 to 40 cm H ₂ O/l/second	0 to 40 cm H ₂ O/l/second
Resolution	1 cmH ₂ O/ l/s	1 cmH ₂ O/ l/s
Sensor specifications		
Dead space	9.5 ml	2.5 ml
Resistance at 30 l/minute	0.5 cmH ₂ O	<i>not applicable</i>
Resistance at 10 l/minute	<i>not applicable</i>	1.0 cmH ₂ O

Conditions exceeding normal

Accuracy specifications during warm-up (first 2 to 10 minutes after power is turned on):

Airway pressure(P_{aw}) accuracy: ± 2 cmH₂O

Tidal volume accuracy: $\pm 10\%$ or 100 ml (adult); $\pm 10\%$ or 10 ml (pediatric)

1.7.6 NeuroMuscular Transmission (N-XNMT)

NMT stimulation modes

Stimulation modes

Train of four (TOF)

Double burst, 3.3 (DBS)

Single twitch (ST)

50 Hz tetanic + post tetanic count (PTC)

Measurement intervals (TOF and DBS): manual; 10 seconds, 12 seconds, 15 seconds, 20 seconds, 1 minute, 5 minutes, 15 minutes

Measurement intervals (ST): manual; 1 second, 10 seconds, 20 seconds

Stimulator

Stimulus pulse: Square wave, constant current

Pulse width: 100, 200 or 300 μ s

Stimulus current range (supramax and manual): 10 to 70 mA with 5 mA steps

Stimulus current accuracy: 10% or ± 3 mA (whichever is greater)

Maximum load: 3 k Ω

Maximum voltage: 300 V

Regional block mode

Stimulation modes: Single twitch

Intervals: 1 second, 2 seconds, 3 seconds

Stimulus pulse: Square wave, constant current

Pulse width: 40 μ s

Stimulus current range: 0 to 5.0 mA with 0.1 mA steps

Stimulus current accuracy: 20% or 0.3 mA (whichever is greater)

1.7.7 Recorder (N-XREC)

Principle: thermal array

Print resolution

Vertical: 8 dots/mm (200 dots/inch)

Horizontal: 32 dots/mm (800 dots/inch) at speed of 25 mm/second and slower

Paper width: 50 mm, printing width 48 mm

Traces: selectable; 1, 2, or 3 traces

Print speed: 1, 6.25, 12.5, 25 mm/second

Chapter 2. Installation and Functional Check

2.1 Introduction	2-1
2.2 Installation.....	2-1
2.2.1 Front panel components	2-1
Patient connectors panel (F-MX).....	2-2
Patient connectors panel (F-MXG).....	2-3
2.2.2 Rear panel.....	2-4
2.2.3 Connection to network.....	2-5
2.2.4 Sample gas exhaust connections.....	2-5
Returning gas to the patient circuit.....	2-5
Scavenging through direct connection	2-6
2.3 Interfacing	2-7
2.3.1 Interfacing a printer.....	2-7
2.3.2 Interfacing a computer	2-7
2.3.3 Interfacing other devices using the analog/digital output connector	2-7
Digital outputs.....	2-7
Analog outputs.....	2-8
2.3.4 Setting the analog output signals.....	2-9
2.4 Connector pin assignments	2-10
2.4.1 Analog/digital output connector (X1)	2-10
2.4.2 RS-232 serial communication interface/local printer connector (X2).....	2-11
2.4.3 Network identification plug connector (X3).....	2-11
2.4.4 Ethernet connector (X4).....	2-12
2.4.5 Remote Control connector (X5).....	2-12
2.5 Functional check	2-13
Using the Functional Check Form	2-13
Recommended tools.....	2-13
2.5.1 Functional inspection	2-14
Recorder test (if N-XREC option is included).....	2-16
Memory card (PCMCIA) test (if N-XDNET option is included)	2-16
Network test (if N-XNET or N-XDNET option is included)	2-17
ECG board test	2-18
STP board test	2-18
NIBP board test.....	2-19
Pulse oximetry test (if N-XOSAT or N-XNSAT option is included)	2-19
Gas measurement and spirometry test	2-20
NeuroMuscular Transmission (NMT) test (if N-XNMT option is included).....	2-21
2.5.2 Performance checks.....	2-23
Functional Check Form	<i>End of this chapter</i>

Table of Figures

Figure 2-1. Cardiicap/5 monitor (F-MXG).....	2-1
Figure 2-2. Patient connections—Hemodynamic (F-MX).....	2-2
Figure 2-3. Patient connections—Hemodynamic with gas (F-MXG)	2-3
Figure 2-4. Rear panel (F-MXG)	2-4
Figure 2-5. Scavenging through ventilator reservoir	2-5
Figure 2-6. Gas return to patient circuit in AS/3 ADU	2-6
Figure 2-7. Connection directly to a scavenging system	2-6

2. INSTALLATION AND FUNCTIONAL CHECK

2.1 Introduction

This chapter includes the information needed to install and check the monitor. Information for connecting other equipment, such as a printer or computer, is also included. If you need assistance concerning the installation, please contact your authorized distributor.

2.2 Installation

2.2.1 Front panel components

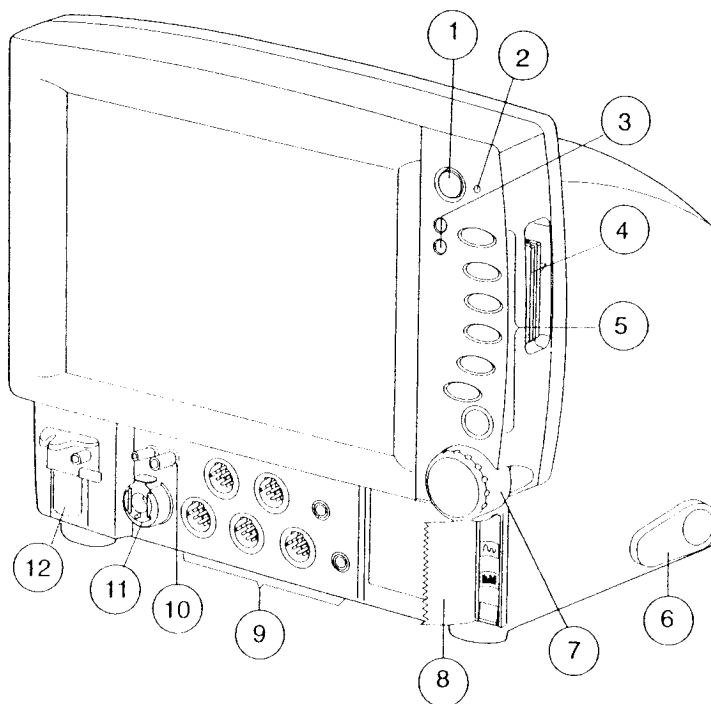

Figure 2-1. Cardiocap/5 monitor (F-MXG)

- (1) Power On/standby key
- (2) External power indicator / Battery charge status LED
- (3) Alarm indicators
- (4) Insertion slots for memory cards (Data card and Menu card)
A cover for the slots is available. See the *Spare Parts* chapter later in this manual.
- (5) Direct access keys
- (6) Adjustable rear support
- (7) ComWheel

- (8) Recorder (N-XREC option)
NOTE: The two-button recorder (shown) is for Cardiacap/5 monitors using software version 3.0 or higher. A one-button recorder was available previously.
- (9) Patient connectors
- (10) Spirometry connectors
- (11) NIBP connector
- (12) D-fend housing (F-MXG only)

Patient connectors panel (F-MX)

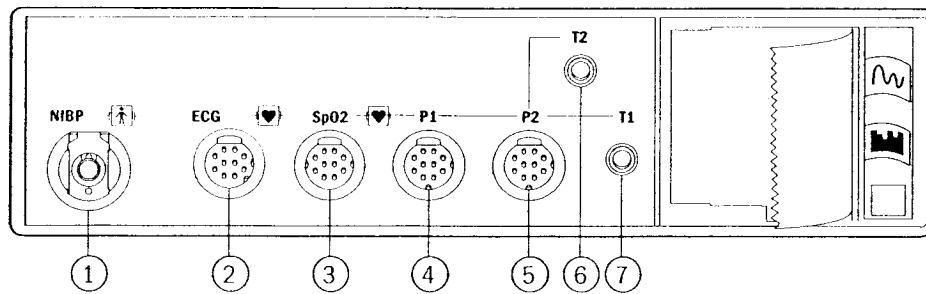





Figure 2-2. Patient connections—Hemodynamic (F-MX)

- (1) NIBP
- (2) ECG
- (3) SpO₂
NOTE: Connector type depends on which SpO₂ option is installed:

	Connector for Datex-Ohmeda standard pulse oximetry
	Connector for Datex-Ohmeda enhanced pulse oximetry
	Connector for Nellcor® compatible pulse oximetry

- (4) Invasive pressure, P1 (N-XP option)
- (5) Invasive pressure, P2 (N-XP option)
- (6) Temperature, T2 (N-XP option)
- (7) Temperature, T1

Patient connectors panel (F-MXG)

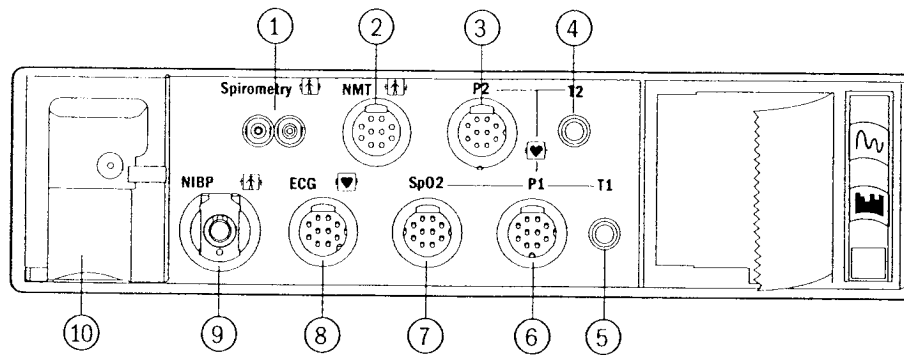





Figure 2-3. Patient connections—Hemodynamic with gas (F-MXG)

- (1) Spirometry (N-XV option)
- (2) NMT (N-XNMT option)
- (3) Invasive pressure, P2 (N-XP option)
- (4) Temperature, T2 (N-XP option)
- (5) Temperature, T1
- (6) Invasive pressure, P1 (N-XP option)
- (7) SpO₂

NOTE: Connector type depends on which SpO₂ option is installed:

 SpO₂	Connector for Datex-Ohmeda standard pulse oximetry
 SpO₂ (A)	Connector for Datex-Ohmeda enhanced pulse oximetry
 SpO₂ (N)	Connector for Nellcor® compatible pulse oximetry

- (8) ECG
- (9) NIBP
- (10) D-fend housing

2.2.2 Rear panel

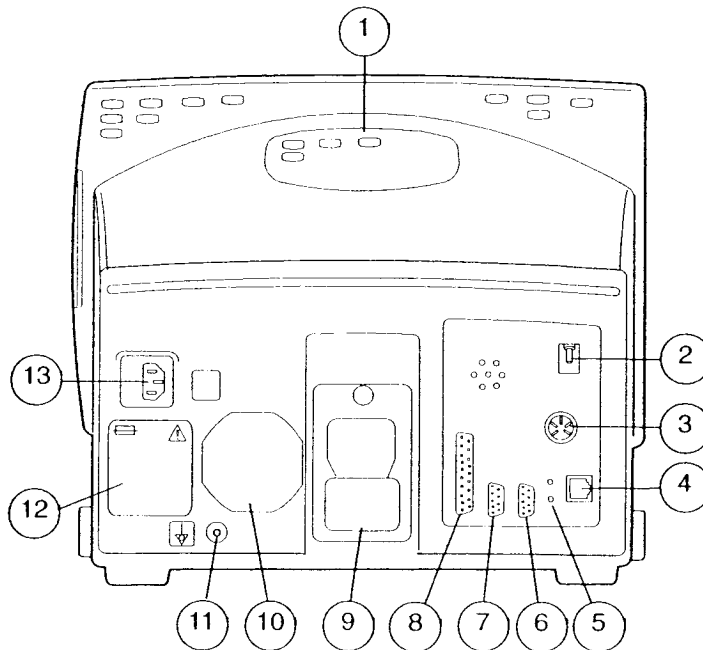

Figure 2-4. Rear panel (F-MXG)

- (1) Built-in handle
- (2) Gas outlet (F-MXG only), X6
- (3) Remote Control connector, X5
- (4) Ethernet connector, X4
- (5) Network connection LEDs
- (6) Network identification plug connector, X3
- (7) Serial communication interface/local printer connector, X2
- (8) Analog/digital output connector, X1
(includes nurse call and defibrillator synchronization signals)
- (9) Mounting attachment
- (10) Dust filter
- (11) Potential equalization
- (12) Fuse and voltage information
- (13) Receptacle for mains power cord and fuses

WARNING: Electrical shock hazard. Connect the power cord to a three-wire, grounded, hospital-grade receptacle only.

CAUTION: Turn off the power before making any rear panel connections.

2.2.3 Connection to network

If either Cardiocap/5 Network option (N-XNET or N-XDNET) is installed, you can connect the Cardiocap/5 to the Datex-Ohmeda S/5 Network and Central. Use the Monitor-Network cable to connect the monitor to the network.

1. Power off the monitor.
2. On the rear panel, connect one of the RJ-45 connectors to connector X4 and connect the Identification Plug to connector X3.
3. Connect the other RJ-45 connector to the corresponding Datex-Ohmeda Central Network connector on the wall box.
4. Power on the monitor.
5. Confirm that the network symbol and the "Connected to Network" message are displayed on the upper part of the screen.



NOTE: The network symbol does not display if the battery symbol is displayed.

2.2.4 Sample gas exhaust connections

When N₂O or volatile anesthetics are used, take precautions against venting these gases into room air. Return the sample gas to the patient circuit or connect the sample gas outlet of the monitor to the scavenging system.

CAUTION: Strong scavenging suction may change the operating pressure of the monitor and cause inaccurate readings or internal damage.

Returning gas to the patient circuit

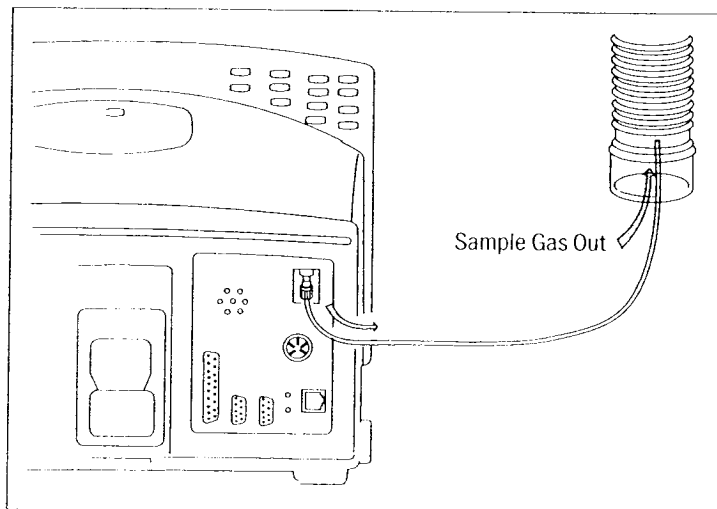

Figure 2-5. Scavenging through ventilator reservoir

- Connect an exhaust line to the sample gas outlet on the rear panel of the monitor.
- Attach the other end of the line to the ventilator reservoir. Make sure that the reservoir tube diameter is at least 2-3 times larger than the exhaust line.

If you use the Datex-Ohmeda AS/3 Anesthesia Delivery Unit (ADU), connect an optional adapter (881644, 5/pkg) to the patient breathing tubes.

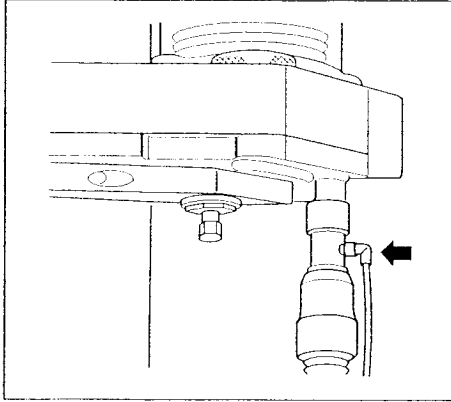

Figure 2-6. Gas return to patient circuit in AS/3 ADU

Scavenging through direct connection

Connect the sample gas outlet only to an open scavenging system where gas is removed at room pressure.

CAUTION: Strong scavenging suction may change the operating pressure of the monitor and cause inaccurate readings or internal damage.

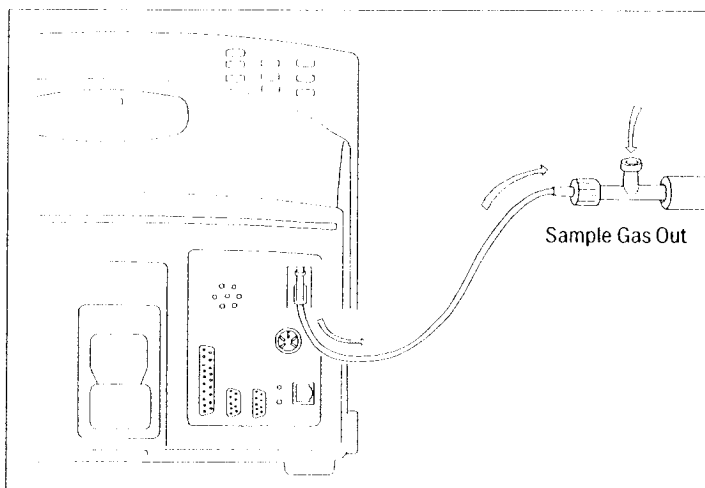

Figure 2-7. Connection directly to a scavenging system

- Connect the exhaust line (733195, 5/pkg) to the sample gas outlet on the monitor.
- Attach a T-fitting (882377, 5/pkg) between the exhaust line and the scavenging tube to prevent vacuum in the tube.

2.3 Interfacing

WARNING: Electrical shock hazard. When you connect equipment to the Cardiocap/5 input and output connectors, you are configuring a medical system and are responsible for ensuring that the system complies with IEC/EN 60601-1-1 and with local requirements.

2.3.1 Interfacing a printer

You can connect a PCL-5 compatible laser printer to the Cardiocap/5 using the Datex-Ohmeda Light Monitor-Printer cable. Connect this serial-to-parallel interface cable between the local printer connector (X2) and the printer. For ordering details, refer to the Datex-Ohmeda *Supplies & Accessories Catalog*.

WARNING: Connecting the power supply cord of the printer to the wall socket may cause the printer leakage current to exceed the limit specified for medical equipment. Always connect the printer to an appropriate isolation transformer.

2.3.2 Interfacing a computer

It is possible to interface a computer to the Cardiocap/5. For further information, please contact your authorized Datex-Ohmeda distributor.

WARNING: Connecting the power supply cord of the computer to the wall socket may cause the computer leakage current to exceed the limit specified for medical equipment. Always connect the computer to an appropriate separating transformer.

2.3.3 Interfacing other devices using the analog/digital output connector

The analog/digital output connector (X1) can be used to interface other devices to the Cardiocap/5.

Digital outputs

Defibrillation sync

The ECG generates the defibrillation sync digital output signal. The signal is set to a high state (logic 1: 2.8 to 5.0 VDC) when activated. After 10 ms, it is set back to a low state (logic 0: 0 to 0.8 VDC). The signal is regenerated only after returning to the low state. The delay from the R-wave peak to the start of the signal is 35 ms maximum.

Nurse call

The nurse call digital output signal is generated by red, yellow, and white alarms. When activated, the signal is set to a high state and remains at a high state until the alarm situation is over or the **Silence Alarms** key is pressed. The high state (logic 1) ranges from 2.8 to 5.0 VDC while the low state (logic 0) ranges from 0 to 0.8 VDC. The nurse call signal also activates a relay that connects X1 (pins 11 and 12).

Analog outputs

Each analog output signal is scaled linearly between -5 and +5 volts. The resolution is 4096 steps over 10 volts, or approximately 0.00244 volts per step. All signal levels are updated every 10 ms.

OFF Default state. No signal is present at the analog output pin.

HR according to selected source (display value)

The original scale of 0 to 300 beats is scaled between 0 and 3 volts.

ECG1, ECG2, ECG3

The original scale of -5000 microvolts to +5000 microvolts is scaled between -5 and +5 volts.

P1 Ire, P2 Ire (Invasive pressure real-time values, low resolution)

The original scale of -20 mmHg to +320 mmHg is scaled between -0.2 and +3.2 volts.

P1 hre, P2 hre (Invasive pressure real-time values, high resolution)

The original scale of -20 mmHg to +50 mmHg is scaled between -2 and +5 volts.

Pleth The original scale of -100% to 100% is scaled between -5 and +5 volts.

SpO₂>40, SpO₂>60, SpO₂>80 (beat-to-beat, display value, 10 s average)

The original scale of 40 to 100% (SpO₂>40), 60 to 100% (SpO₂>60) or 80 to 100% (SpO₂>80) is scaled between -5 and +5 volts.

CO₂ The original scale of 0% to 10% is scaled between 0 and +5 volts. Values greater than 10% are set to 10%. (Airway gas special indications are applied. See *Special indications for analog outputs* below.)

AA (anesthetic agent)

The original scale of 0% to 10% is scaled between 0 and +5 volts. Values greater than 10% are set to 10%. (Airway gas special indications are applied. See *Special indications for analog outputs* below.)

O₂ The original scale of 0% to 100% is scaled between 0 and +5 volts. (Airway gas special indications are applied. See *Special indications for analog outputs* below.)

N₂O The original scale of 0% to 100% is scaled between 0 and +5 volts. (Airway gas special indications are applied. See *Special indications for analog outputs* below.)

Paw (airway pressure)

The original scale of -20 cmH₂O to +80 cmH₂O is scaled between -5 and +5 volts. (Airway gas sensor failure is applied. See *Special indications for analog outputs* below.)

Flow The original scale of -100 l/minute to +100 l/minute is scaled between -5 and +5 volts. (Airway gas sensor failure is applied. See *Special indications for analog outputs* below.)

Volume The original scale of -2.5 liters to +2.5 liters is scaled between -5 and +5 volts. (Airway gas sensor failure is applied. See *Special indications for analog outputs* below.)

Resp The original scale of -5000 mohms is scaled between -5 and +5 volts.

RR The respiration rate display of 0 to 150 breaths per minute is scaled between 0 and +1.5 volts.

T1, T2 The original temperature scale of 0 °C to 50 °C is scaled between 0 and +5 volts.

TEST SIGNALS -5 V, 0 V, +5 V

Steady signals with one of the listed values.

TEST 1 Test signal of a triangle shape with a base width of 1 second (0 V minimum; +5 V maximum).

TEST 2 Test signal of a triangle shape with a base width of 4 seconds (-5 V minimum; +5 V maximum).

Special indications for analog outputs

Start-up indication occurs when the monitor is started by a power on or by an internal restart (caused by a fatal failure). The indication consists of three triangle-shaped signals with a base width of 1 second, base of 0 volts, and a height of 5 volts.

Airway gas calibration: During calibration of any gases, a square wave is generated. The minimum value is 0 volts, the maximum value is +2 volts, the minimum phase length equals the maximum phase length, and the frequency is 0.25 Hz.

Airway gas zeroing: During zeroing of any gases, a square wave is generated. The minimum value is 0 volts, the maximum value is +5 volts, the minimum phase length equals the maximum phase length, and the frequency is 0.25 Hz.

Airway gas occlusion: During occlusion of any gases, a triangle-shaped signal is generated with a base width of 4 seconds, a minimum value of 0 volts, and a maximum value of +5 volts.

Airway gas air leak: During an air leak of any gases, a triangle-shaped signal is generated with a base width of 3 seconds, a minimum value of 0 volts, and a maximum value of +5 volts.

Airway gas sensor failure: During a sensor failure, a triangle-shaped signal is generated with a base width of 2 seconds, a minimum value of 0 volts, and a maximum value of +5 volts.

2.3.4 Setting the analog output signals

To set the analog output signals:

1. Press the ComWheel and select **Monitor Setup** from the Main Menu.
2. Select **Install/Service** and enter the password (16-4-34).
3. Select **Installation**.
4. Select **Analog Outputs** and set the channels.
5. Press the **Normal Screen** key.

2.4 Connector pin assignments

2.4.1 Analog/digital output connector (X1)

CON./ I/O BOARD	SIGNAL	DIRECTION	LEVEL	FUNCTION
X1/1	GND	-	0V	GND
X1/2	N/C			
X1/3	DSYNOUT	0	CMOS	Defibrillation sync.
X1/4	N/C			
X1/5	NCALLOUT	0	CMOS	Nurse Call
X1/6	N/C			
X1/7	GND	-	0V	GND
X1/8 to X1/10	N/C			
X1/11	NCALLB1	-	-	Nurse call relay
X1/12	NCALLB2	-	-	Nurse call relay
X1/13	N/C			
X1/14	A1OUT	0		Analog output
X1/15	+5VOUT	-	+5V	+5 V output voltage
X1/16	N/C			
X1/17	A3OUT	0		Analog output
X1/18	N/C			
X1/19	A2OUT	0		Analog output
X1/20	A0OUT	0		Analog output
X1/21 to X1/37	N/C			
X1/38	ECGOUT	0		Analog ECG-signal output
X1/39 to X1/43	N/C			
X1/44	GND	-	0V	GND

2.4.2 RS-232 serial communication interface/local printer connector (X2)

Connector X2 provides an RS-232 serial communication link with handshaking.

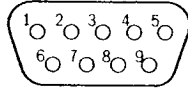

D9 male connector pinout (front view)

D9 Male

CON./ I/O BOARD	SIGNAL	DIRECTION	LEVEL	FUNCTION
X2/1	GND	-	0V	Ground
X2/2	RXD	I	RS232	Serial bus, Receive
X2/3	TXD	O	RS232	Serial bus, Transmit
X2/4	+5VS	-	+5V	+5 V output voltage, maximum 200 mA
X2/5	GND	-	0V	Ground
X2/6	N/C			
X2/7	RTS	O	RS232	Serial bus, Request To Send
X2/8	CTS	I	RS232	Serial bus, Clear To Send
X2/9	N/C			

2.4.3 Network identification plug connector (X3)

The coding element interface is used for bedside address-coding for the Ethernet. The element is connected to the 9-pin female connector.

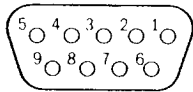

D9 female connector pinout (front view)

D9 Female

CON./ I/O BOARD	SIGNAL	DIRECTION	LEVEL	FUNCTION
X3/1	IDCS	O	CMOS	ID chip select
X3/2	IDCLK	O	CMOS	ID clock
X3/3	IDDI	I	CMOS	ID data in
X3/4	IDDO	O	CMOS	ID data out
X3/5	GND	-	0V	Ground
X3/6	+5VB	-	+5V	+5V output voltage
X3/7	N/C			
X3/8	N/C			
X3/9	GND	-	0V	Ground

2.4.4 Ethernet connector (X4)

The Ethernet interface meets IEEE 802.3 specifications (10BASE-T) with hospital-grade approved power and data transformers.

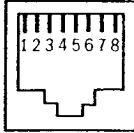

Ethernet connector (front view)

PIN	SIGNAL	DIRECTION	FUNCTION
1	Tx +	O	Transmit data
2	Tx -	O	Transmit data
3	Rx +	I	Receive data
4	N/C		
5	N/C		
6	Rx -	I	Receive data
7	N/C		
8	N/C		

2.4.5 Remote Control connector (X5)

CON./ I/O BOARD	SIGNAL	DIRECTION	LEVEL	FUNCTION
X5/1	CLK	I/O	TTL	Keyboard clock
X5/2	DATA	I/O	TTL	Keyboard data
X5/3	-			
X5/4	GND	-	0V	Ground
X5/5	+5 VB	-	+5V	+5V supply voltage

2.5 Functional check

The functional check consists of instructions to verify the correct operation of the Cardiocap/5. The functional check is recommended after installing the monitor and after long storage.

The first part of the instructions contains procedures that are performed through the service menu. These checks are especially recommended if the monitor has been stored and not used for a long time.

When installing a new monitor, performance checks with a simulator and accessories are typically enough to ensure the correct function of the monitor. We recommend that you always perform the complete functional check to confirm that no hardware failures occurred during transport.

The instructions are for the maximum functional configuration of the Cardiocap/5. Perform the procedures in ascending order and skip items that do not correspond to your monitor configuration.

Using the Functional Check Form

A *Functional Check Form* is included at the end of this chapter. Copy this form and complete the "checklist" as you perform the functional check procedures.

NOTE:  means to sign the form after performing the procedure.

Recommended tools

Tool	Order Number
SpO ₂ finger sensor for the pulse oximetry option. NOTE: With the N-XNSAT option, use only Nellcor sensors (DS-100A, for example). With the N-XOSAT option, use only Datex-Ohmeda sensors (OXY-F1-H, for example). For standard pulse oximetry, use only Datex-Ohmeda sensors (OXY-F4-N, for example).	
Simulator capable of simulating ECG, RESP, and invBP	Obtain locally
Adult NIBP cuff	572435
Adult NIBP hose	877235
Temperature test plug set	884515
MemCard - Menu, English (only for monitors with Data card option)	893860
MemCard - Data, English (only for monitors with Data card option)	887045
Sampling line 3.0 m (only for monitors with gas option)	73319

If the NMT option (N-XNMT) is installed, you will need these additional items:

Tool	Order Number
NMT simulator	871251
NMT ElectroSensor	888416
NMT MechanoSensor	888418
NMT Sensor Cable	888414 or 888415
3 kΩ 0.25W 1% resistor	Obtain locally

2.5.1 Functional inspection

1. Connect the power cord.

Check that the green external power indicator/battery charge status LED turns on or starts flashing.



2. Switch the monitor on. Check that the monitor starts up as follows:

- The start-up sound is heard from the loudspeaker
- The normal monitoring screen appears
- The alarm LEDs turn on and off after about 20 sec
- No error messages appear onto the screen
- If the monitor contains a recorder, start-up information is printed. Verify that the time and date on the printout are correct.



3. Check the loudspeaker by adjusting the alarm volume in the Alarms Setup menu:

Press the ComWheel to enter the Main Menu and select:

Alarms Setup

Alarm Volume

Test the whole volume scale from 1 to 10 by turning the ComWheel and check that the alarm volume changes correspondingly. The alarm sound should be clear and audible at all settings.

Select **Main Menu**.



4. Check that the time and date are correct and adjust, if necessary:

Press the ComWheel to enter the Main Menu and select:

Monitor Setup

Time and Date

NOTE: To prevent the loss of trend data, you cannot change the time and date after starting a new case or admitting a new patient.

NOTE: If the clock shows a time of 0:00 continuously after start-up, the SRAM/Timekeeper battery on the CPU board needs to be replaced.

To return to the Main Menu, select **Previous Menu**.



5. Check that the supply voltages are within the given limit values:

Press the ComWheel to enter the Main Menu and select:

Monitor Setup

Install/Service (Password 16-4-34)

Service View (Password 26-23-8)

Monitor

Voltages

Voltages	Mains power ON	Mains power OFF
VDD/BAT	14.3 to 16.2	10 to 13
VIN 15VB	10 to 14.5	10 to 13.5
VDD	15.0 to 16.5	
+12V	11.4 to 12.6	
+15VD	14.25 to 15.85	
+15V	14.4 to 15.6	
-15V	15.6 to 14.4	
+2.5VREF	2.40 to 2.54	
TEMP	10 to 60	
BATVOLT	10 to 14.5	10 to 13.5
VDD/TEMP OK	0	1
CHG ON	1	0
D Sync test count	0	



6. Check the back-up battery:

Disconnect the power cord (without switching the monitor to standby).

Check that the monitor continues to run normally on battery power. The battery indicator should appear in the upper right corner of the screen:



Reconnect the power cord and check that during charging, the charging symbol is displayed and the battery charge status LED starts flashing:

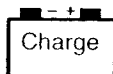

Recorder test (if N-XREC option is included)

- Open the paper compartment cover and check that the "Recorder: Cover open" message is displayed. Close the cover.



- To record waveforms, press the ComWheel to enter the Main Menu and select:
Record/Print
Record Waveforms
Record Wave

Check that the recording quality is acceptable.
 To stop recording, select **Stop Wave**.

Press the **Record Waveform/Stop** key and verify that the selected waveforms print.
 Press the key again to stop recording.

Press the **Record Trend/Stop** key and verify that the selected trends print.
 Press the key again to stop recording.



Memory card (PCMCIA) test (if N-XDNET option is included)

- Press the ComWheel to enter the Main Menu and select:
Monitor Setup
Install/Service (Password 16-4-34)
Service View (Password 26-23-8)
Modules
Memory Module

Check that the module is recognized (**YES**) and that the memory on the memory board and the PCMCIA controller passed the tests (**OK**):

Module present	YES	ROM	OK	PCMCIA	OK
Module active	YES	RAM	OK	EEPROM	OK



- Select **Communication** and check that **Interface status** states **Active** continuously and the error counter values on the bottom part of the menu are stable.



- Select **Module Status** and insert a memory card labeled "Menu" in the memory card slot. Check that within one minute:
 - The "Menu card inserted" message appears in the message field.
 - The white Menu card symbol appears on the upper right corner of the screen if the battery is not charging (the battery charging symbol is not present).

Wait until the information regarding the memory card slot is fully updated in the service menu, then check that the screen shows the **Card type** is **MENU** and the **File system** is **ATA**. Check that the rest of the information for the memory card slot is reliable and no errors have been detected.

Repeat the test using a Data card in the other memory card slot. Verify that the green Data card symbol is displayed if the battery charging symbol is not present, the "Data card inserted" message appears, and the **Card type** is **DATA**).



Network test (if N-XNET or N-XDNET option is included)

12. Connect the Monitor-Network cable and the Identification plug to the monitor. To check the connection to the network, check the Network connection LEDs between the connectors:
 - Yellow LED should flash intermittently.
 - Green LED should be lit continuously.



13. Check that the Datex-Ohmeda Network symbol  is displayed on the upper right corner of the screen).

NOTE: If the battery is being charged, the battery charging symbol is displayed instead of the network symbol.

A message regarding the connection to the Datex-Ohmeda Information Center should appear in the message field on the screen.



14. To enter the Communication service menu and check Network information, press the ComWheel to enter the Main Menu and select:

Monitor Setup
Install/Service (Password 16-4-34)
Service View (Password 26-23-8)
Monitor
Communication
Network

Check that:

- The **Location ID number** matches the ID plug connected to X3.
- The packets and bytes **IN** is increasing slowly.
- The packets and bytes **OUT** is increasing quickly.
- **Connections** shows the names of the connected networks.
- The data error counters (**CRC**, **Frame**, and **Transm.**) are stable.

NOTE: The counters may show values greater than 0. However, any values increasing continuously indicate a problem.



15. Check that the hardware error counters (**Intern.**, **Missed**, **FIFO**, and **Overrun**) all show 0 (zero). A value greater than zero for any counter indicates a problem on the CPU board.



ECG board test

16. Enter the ESTP: ECG service menu:

To return to the Service View menu, select **Previous Menu** as needed until you can select **Modules** and then select **ESTP : ECG**.

or

Press the ComWheel and select:

Monitor Setup

Install/Service (Password 16-4-34) -

Service View (Password 26-23-8)

Modules

ESTP: ECG

Check the Service Data:

- The **Timeouts**, **Bad checksums**, and **Bad c-s by mod** values are not increasing faster than 50 per second.
- The ECG/RESP board memories passed the internal memory test (**RAM**, **ROM**, and **EEPROM** all show **OK**).



17. Check that the **Power Freq** value (the module mains power frequency) has been set according to the supply frequency. If necessary, change the setting by selecting **Power Freq**.



18. Check that **Resp Available** and **Resp** measurement both show **ON**.

NOTE: The Resp measurement shows **OFF** if **Resp** is not selected to the screen setup.

To set up the screen, press the ComWheel and select:

Monitor Setup

Screen Setup

Waveform Fields or **Digit Fields**



STP board test

19. To enter the ESTP: STP service menu, press the ComWheel and select:

Monitor Setup

Install/Service (Password 16-4-34) -

Service View (Password 26-23-8)

Modules

ESTP: STP

Check that the **Timeouts**, **Bad checksums**, and **Bad c-s by mod** values are not increasing faster than 50 per second.

Check that the STP board memories passed the internal memory test (**RAM**, **ROM**, and **EEPROM** all show **OK**).



20. Check that the protection for temperature calibration is ON:

Protect key in the menu should state **OFF**

Protect mode should state **ON**.

If necessary, change the Protection mode in the Calibrations menu.



NIBP board test

21. Press **Previous Menu** as needed to return to the Modules menu, then select **NIBP** to enter the NIBP service menu.

Check that the **Timeouts**, **Bad checksums**, and **Bad c-s by mod** values are not increasing faster than 50 per second.

Check that the NIBP board memories passed the internal memory test (**RAM**, **ROM**, and **EEPROM** all show **OK**).



Pulse oximetry test (if N-XOSAT or N-XNSAT option is included)

22. Configure the monitor screen to display the Pleth waveform and other pulse oximetry parameters by pressing the ComWheel and selecting:

Monitor Setup

Screen Setup

Waveform Fields

Select a field (**Field1**, for example) and choose PLETH as the parameter.

Connect the appropriate SpO₂ finger sensor to the monitor (use a Nellcor sensor for the N-XNSAT option; a Datex-Ohmeda sensor for the N-XOSAT option). Attach the sensor to your finger.

Check that an acceptable SpO₂ reading and a proper SpO₂ waveform appear on the screen.



23. Enter the SpO₂ options service menu by pressing the ComWheel and selecting:

Monitor Setup

Install/Service (Password 16-4-34) -

Service View (Password 26-23-8)

Modules

M-NSAT

Check that the **Timeouts**, **Bad checksums**, and **Bad c-s by mod** values are equal to 0 (zero).

Check that **ROM** shows **OK**, indicating it passed the internal memory test.



24. Check that the three error indicators (**MP-203 Error**, **QUART Error**, and **I/O Error**) show **NO**.

NOTE: **MP-203 Error** represents the NSAT or OSAT pulse oximetry board.



Gas measurement and spirometry test

25. Connect a sample line to the D-fend.

If the monitor is configured with Patient Spirometry (N-XV option), press the ComWheel to enter the Main Menu and select:

Monitor Setup
Screen 1 Setup
Waveform Field
Field 2 (choose **Paw**)
Field 3 (choose **Flow**)

NOTE: If you just turned on the monitor, wait until the "Calibrating gas sensor" message disappears from the screen. Then, enter the Gas Unit - General service menu by pressing the ComWheel and selecting:

Monitor Setup
Install/Service (Password 16-4-34)
Service View (Password 26-23-8)
Modules
Gas Unit
General

Check that the configuration shown corresponds with the configuration of your monitor.



26. Check that the **Timeouts**, **Bad checksums**, and **Bad c-s by mod** values are not increasing faster than 50 per second. A value increasing faster than this indicates a failure in Module Bus communication. Refer to the *Troubleshooting* chapter.



27. Select **Previous Menu** to return to the Gas Unit menu, then select **Gases**. Check that the displayed **Ambient** value corresponds with the current ambient pressure (± 20 mmHg).



28. Check that the **Amb-Work** value in the service menu is within the range of 40-75 mmHg.



NeuroMuscular Transmission (NMT) test (if N-XNMT option is included)

29. Cycle power to the monitor and wait until the normal monitoring screen appears. Then, configure the monitor for NMT measurement:
- Press the ComWheel and select **Monitor Setup**.
Select **Screen Setup**.
Select **Digit Fields**, select a field, and choose **NMT**.
 - To preset the NMT measurement settings, press **NMT**.
Select **Stimulus Mode** and choose **TOF**.
Select **Cycle Time** and choose **10 sec**.
 - Select **NMT Setup**.
Select **Current** and choose **S(70 mA)**.
Select **Pulse width** and choose **200 μ S**.
Select **Stim. Beep Volume** and choose **2**.

Check that the NMT header with related information is displayed in the chosen digit field.



30. To enter the NMT service menu, press the ComWheel and select **Monitor Setup**. Then select:
Install/Service (password 16-4-34)
Service (password 26-23-8)
Modules
NMT

Check that the **Timeouts**, **Bad checksums**, and **Bad c-s by mod** values are not increasing faster than by 50 per second. Check that the NMT memory passed the internal memory test (**RAM**, **ROM** and **EEPROM** all state **OK**).



31. Check that:
- In the digit fields, the NMT header, NMT-related information, and "Cable off" are shown.
 - In the service menu, **Cable** states **OFF**.

Connect an ElectroSensor to the NMT sensor cable and plug the cable into the NMT connector on the front panel. Check that the digit field message changes to "Measurement OFF" and **Cable** in the service menu states **EMG** and **ELECTR. OFF**.



32. Perform the stimulus current test:
- Connect a 3 k Ω resistor between the ElectroSensor stimulus electrode leads (brown and white).
- In the NMT service menu, select **Start Curr. test**. Check that the test was successful with all three test currents, that is, **Current test (mA)**: states **30 OK**, **50 OK**, and **70 OK**.
- Connect the NMT ElectroSensor leads to the NMT simulator. Set the switch on the simulator to "Fade off" and turn the knob to "max." In the service menu, check that **Cable** states **EMG**.



33. Start NMT measurement (TOF) by selecting **NMT Setup** and selecting **Start-up**. Press **Previous Menu** to return to the NMT service menu.
- In the digit field, when the "Supramax search" message changes to "Setting reference," check that the detected supramaximal current is less than 70 mA (the **Current set** value on the service screen is less than 700).
- Check that four successive stimulus pulses are generated in 10-second intervals. During each stimulus pulse, a tone sounds and a small asterisk (*) appears in the digit field. In the digit field, check that **TOF%** is within 95-105, **Count** is 4, and **T1%** is within 95-105.
- In the NMT service menu, check that **T1%**, **T2%**, **T3%**, **T4%** and **Ratio%** are all within 950-1059. Check that the **Noise** value stays under 50.



34. In the NMT service menu, select **NMT Setup** and change the stimulus **Pulse Width** to **100 μs**. Then press **Previous Menu** to return to the NMT service menu.
- In the digit field, check that **TOF%** is still within 95-105, **Count** is 4, and **T1%** is within 95-105.
- Change the stimulus pulse width to **300 μs** and check the same parameters.



35. Turn the knob on the NMT simulator to 0 (zero). In the NMT service menu, check that the values for **T1%**, **T2%**, **T3%**, **T4%** turn to **0** and the **Ratio%** shows - - -. In the digit field, **TOF%** should also state - - -; **Count** and **T1%** should show **0**.



36. Turn the NMT simulator knob back to "max." Change the stimulus mode to Double Burst Stimulation (select **NMT Setup - Stimulus Mode - DBS**).
- Check that only two stimulus pulses are given in a 10-second interval. In the NMT service menu, check that **T1%**, **T2%**, and **Ratio%** are still within 950-1059. In the digit field, check that **DBS%** is within 95-105, **Count** is 2, and **T1%** is within 95-105.



37. Change the stimulus mode to Single Twitch stimulation (ST). Check that the monitor starts giving only one stimulus pulse with a 1-second interval. Note the time when the ST stimulation started.
- In the service menu, check that the **T1%** value is within 950-1059. In the digit field, the **Count** value should be 1 and **T1%** within 95-105.



38. Continue single twitch stimulation. Five minutes after the start of ST stimulation, check that the NMT measurement stops and the "Measurement OFF" message appears in the NMT digit field.



39. Replace the NMT ElectroSensor with the NMT MechanoSensor. In the NMT service menu, check that **Cable** states **PIEZO**.



2.5.2 Performance checks

1. Configure the monitor screen to display all parameter information.

Press the ComWheel to enter the Main Menu and select:

Monitor Setup – Screen Setup – Waveform Fields/Digit Fields

An example is shown below:

Waveform Fields	Digit Fields
Field 1 – ECG1	Field 1 – T1 (or Temp)
Field 2 – Paw	Field 2 – NIBP
Field 3 – P1	Field 3 – Resp
Field 4 – P2	Field 4 – Gases
Field 5 – Pleth	
Field 6 – CO ₂	

Select **Split Screen – None**

To return to the Normal Screen, press the **Normal Screen** key.

Connect the patient simulator and check that all parameter information is displayed as configured.

NOTE: InvBP waveforms are not shown without a patient simulator.

Preset the measurement settings for parameters as follows, for example:

ECG - ECG Setup - HR Source - AUTO

Invasive Pressures

P1 'ART' Setup – Label – ART

P2 'CVP' Setup – Label – CVP

Press the ComWheel to enter the Parameters menu and select:

Pulse Oximetry – Pleth Scale – AUTO

Airway Gas – Spirometry Setup – Scaling – Indep.

Paw Scale – 20

Flow Scale – 15

Resp Setup – Size – 1.0

Resp Rate Source – AUTO

Detection Limit – AUTO

NOTE: The RESP waveform or Digit Field on the screen must be selected before you can turn on the respiration measurement.



2. Connect the patient simulator to the ECG and invBP connectors, connect an SpO₂ finger sensor to the SpO₂ connector, and connect the temperature test plug to a Temp connector. Attach the SpO₂ sensor to your finger. Check that:

- The simulated waveforms are good.
- The SpO₂ value is in the expected range
- The Pleth waveform is normal.



3. Set the invBP simulator to +100 mmHg static pressure. Push the ZERO button and check that :

- The invBP waveforms set on the baseline.
- The digital values go to zero.

Set the simulator to 0 mmHg and press ZERO. After the zeroing is completed, turn the simulator to dynamic mode and check that the waveform is normal.



4. Check that the "No probe" message is displayed when an SpO₂ sensor is not connected.

Connect an SpO₂ finger sensor to the monitor (but not to a finger). Check that "Probe off" (for standard pulse oximetry), "Check probe" (for N-XOSAT), or "Pulse search" then "Check probe" (for N-XNSAT) is displayed.



5. Attach the SpO₂ sensor to your finger and check that the pleth waveform is displayed and the SpO₂ value is in the expected range (95-99%).

Check that the HR value is calculated from SpO₂ when the ECG and InvBP (P1/P2) cables are not connected.



6. Remove the SpO₂ sensor from your finger and check that "Probe off" (for standard pulse oximetry) or "Check probe" (for N-XOSAT or N-XNSAT) is displayed.

Disconnect the sensor from the monitor and check that the "No probe" message is displayed.



7. Attach an adult NIBP cuff onto your arm and perform one NIBP measurement. Check that the cuff is identified (**Adult** appears in the NIBP digit field for a short time).

Check that the measurement result is reasonable.



8. Block the tip of the sampling line with your finger and check that the "Sample line blocked" message is displayed on the monitor screen within 30 seconds.

Detach the D-fend and check that the "Check D-fend" message is displayed on the monitor screen within 30 seconds.



9. Reattach the D-fend. Breathe shortly into the sampling line. Check that the CO₂ waveform moves up on the screen.



After completing the check, be sure to fill in all necessary documents.

Functional Check Form

Datex-Ohmeda Cardiocap/5

Customer	_____		
Service	_____		
Service Engineer	_____	Date	_____

Monitor Configuration

Monitor model:	Hemodynamic model F-MX	<input type="checkbox"/>	Hemodynamic model with gas measurement F-MXG	<input type="checkbox"/>
-----------------------	---------------------------	--------------------------	---	--------------------------

Measurement options		Measurement options (SpO ₂)		
N-XP	Two invasive pressure channels and second temperature (T2)	<input type="checkbox"/>	N-XOSAT Datex-Ohmeda enhanced pulse oximetry <input type="checkbox"/>	
N-XC	CO ₂	<input type="checkbox"/>	N-XNSAT Nellcor compatible pulse oximetry <input type="checkbox"/>	
N-XCO	CO ₂ , N ₂ O, Patient Oxygen	<input type="checkbox"/>	Data collection and data management options	
N-XCAiO	CO ₂ , anesthetic agents, agent identification, N ₂ O, Patient Oxygen	<input type="checkbox"/>	N-XREC Recorder	<input type="checkbox"/>
N-XV	Patient Spirometry	<input type="checkbox"/>	N-XNET Network	<input type="checkbox"/>
N-XNMT	NeuroMuscular Transmission (NMT)	<input type="checkbox"/>	N-XDNET Data card and Network	<input type="checkbox"/>

Functional Inspection

OK = Test OK

N.A. = Test not applicable

Fail = Test Failed

General	OK	N.A.	Fail
1. Battery charge status LED	<input type="checkbox"/>	<input type="checkbox"/>	<input type="checkbox"/>
2. Start-up	<input type="checkbox"/>	<input type="checkbox"/>	<input type="checkbox"/>
3. Loudspeaker	<input type="checkbox"/>	<input type="checkbox"/>	<input type="checkbox"/>
4. Real-time clock	<input type="checkbox"/>	<input type="checkbox"/>	<input type="checkbox"/>
5. Voltage checks	<input type="checkbox"/>	<input type="checkbox"/>	<input type="checkbox"/>
	Acceptance limits		
TEMP		10 to 60 °C	
BATVOLT with mains power ON		10 to 14.5 V	
BATVOLT with mains power OFF		10 to 13.5 V	
6. Back-up battery	<input type="checkbox"/>	<input type="checkbox"/>	<input type="checkbox"/>

Functional Check Form

		OK	N.A.	Fail
Recorder test				
7.	Recorder message	<input type="checkbox"/>	<input type="checkbox"/>	<input type="checkbox"/>
8.	Recording	<input type="checkbox"/>	<input type="checkbox"/>	<input type="checkbox"/>
Memory card (PCMCIA) test				
9.	Memory	<input type="checkbox"/>	<input type="checkbox"/>	<input type="checkbox"/>
10.	Communication	<input type="checkbox"/>	<input type="checkbox"/>	<input type="checkbox"/>
11.	Memory card recognition	<input type="checkbox"/>	<input type="checkbox"/>	<input type="checkbox"/>
Network test				
12.	Connection to network	<input type="checkbox"/>	<input type="checkbox"/>	<input type="checkbox"/>
13.	Communication	<input type="checkbox"/>	<input type="checkbox"/>	<input type="checkbox"/>
14.	Data error counters	<input type="checkbox"/>	<input type="checkbox"/>	<input type="checkbox"/>
15.	Hardware error counters	<input type="checkbox"/>	<input type="checkbox"/>	<input type="checkbox"/>
ECG board test				
16.	Communication and memories	<input type="checkbox"/>	<input type="checkbox"/>	<input type="checkbox"/>
17.	Power frequency	<input type="checkbox"/>	<input type="checkbox"/>	<input type="checkbox"/>
18.	Resp measurement recognition	<input type="checkbox"/>	<input type="checkbox"/>	<input type="checkbox"/>
STP board test				
19.	Communication and memory	<input type="checkbox"/>	<input type="checkbox"/>	<input type="checkbox"/>
20.	Protection for temperature calibration	<input type="checkbox"/>	<input type="checkbox"/>	<input type="checkbox"/>
NIBP board test				
21.	Communication and memory	<input type="checkbox"/>	<input type="checkbox"/>	<input type="checkbox"/>
Pulse oximetry options test				
22.	Recognition and test measurement	<input type="checkbox"/>	<input type="checkbox"/>	<input type="checkbox"/>
23.	Communication and memory	<input type="checkbox"/>	<input type="checkbox"/>	<input type="checkbox"/>
24.	Error status	<input type="checkbox"/>	<input type="checkbox"/>	<input type="checkbox"/>
Gas measurement and spirometry test				
25.	Configuration	<input type="checkbox"/>	<input type="checkbox"/>	<input type="checkbox"/>
26.	Communication	<input type="checkbox"/>	<input type="checkbox"/>	<input type="checkbox"/>
27.	Ambient pressure	<input type="text"/>	Current ambient pressure \pm 20mmHg	
28.	Amb-Work	<input type="text"/>	40 to 75 mmHg	

NeuroMuscular Transmission (NMT) test

- | | | | |
|-------------------------------|--------------------------|--------------------------|--------------------------|
| | OK | N.A. | Fail |
| 29. Recognition | <input type="checkbox"/> | <input type="checkbox"/> | <input type="checkbox"/> |
| 30. Communication and memory | <input type="checkbox"/> | <input type="checkbox"/> | <input type="checkbox"/> |
| 31. ElectroSensor recognition | <input type="checkbox"/> | <input type="checkbox"/> | <input type="checkbox"/> |
| 32. Stimulus current test | <input type="checkbox"/> | <input type="checkbox"/> | <input type="checkbox"/> |

33. TOF measurement with NMT simulator

T1%	<input type="text"/>	950-1059	Supramax. current	<input type="text"/>	< 70 mA
T2%	<input type="text"/>	950-1059	TOF%	<input type="text"/>	95-105
T3%	<input type="text"/>	950-1059	Count	<input type="text"/>	4
T4%	<input type="text"/>	950-1059	T1%	<input type="text"/>	95-105
Ratio%	<input type="text"/>	950-1059			
Noise	<input type="text"/>	< 50			

34. Stimulus pulse width

	100 μ s	300 μ s	Allowed range
TOF%	<input type="text"/>	<input type="text"/>	95-105
Count	<input type="text"/>	<input type="text"/>	4
T1%	<input type="text"/>	<input type="text"/>	95-105

- | | | | |
|-----------------------------|--------------------------|--------------------------|--------------------------|
| | OK | N.A. | Fail |
| 35. No response to stimulus | <input type="checkbox"/> | <input type="checkbox"/> | <input type="checkbox"/> |

36. DBS measurement with NMT simulator

T1%	<input type="text"/>	950-1059	DBS%	<input type="text"/>	95-105
T2%	<input type="text"/>	950-1059	Count	<input type="text"/>	2
Ratio%	<input type="text"/>	950-1059	T1%	<input type="text"/>	95-105

37. ST measurement with NMT simulator

T1%	<input type="text"/>	950-1059	Count	<input type="text"/>	1
			T1%	<input type="text"/>	95-105

- | | | | |
|-------------------------------|--------------------------|--------------------------|--------------------------|
| | OK | N.A. | Fail |
| 38. Automatic measurement off | <input type="checkbox"/> | <input type="checkbox"/> | <input type="checkbox"/> |
| 39. MechanoSensor recognition | <input type="checkbox"/> | <input type="checkbox"/> | <input type="checkbox"/> |

Performance Checks

General	OK	N.A.	Fail
1. Screen setup	<input type="checkbox"/>	<input type="checkbox"/>	<input type="checkbox"/>
2. Waveforms	<input type="checkbox"/>	<input type="checkbox"/>	<input type="checkbox"/>
InvBP measurement			
3. Test with patient simulator	<input type="checkbox"/>	<input type="checkbox"/>	<input type="checkbox"/>
SpO₂ measurement			
4. SpO ₂ sensor detection	<input type="checkbox"/>	<input type="checkbox"/>	<input type="checkbox"/>
5. Test measurement	<input type="checkbox"/>	<input type="checkbox"/>	<input type="checkbox"/>
6. "Probe off" detection	<input type="checkbox"/>	<input type="checkbox"/>	<input type="checkbox"/>
NIBP measurement			
7. Test measurement and cuff identification	<input type="checkbox"/>	<input type="checkbox"/>	<input type="checkbox"/>
Gas measurement			
8. D-fend check	<input type="checkbox"/>	<input type="checkbox"/>	<input type="checkbox"/>
9. CO ₂ waveform	<input type="checkbox"/>	<input type="checkbox"/>	<input type="checkbox"/>

Notes

Signature _____ **Date** _____

Chapter 3. Planned Maintenance

3.1 Introduction	3-1
3.1.1 Using the Planned Maintenance Form.....	3-1
3.1.2 Recommended parts	3-1
3.1.3 Recommended tools and accessories.....	3-2
3.2 Planned maintenance checks	3-3
1. Visual inspection.....	3-3
2. Parts replacement	3-3
3. Functional inspection.....	3-4
4. ECG measurement test.....	3-5
5. Temperature measurement test.....	3-5
6. Non-invasive blood pressure (NIBP) measurement test.....	3-6
7. SpO ₂ measurement test	3-6
8. Invasive blood pressure measurement test.....	3-7
9. Gas measurement test.....	3-7
10. Anesthetic agent identification test.....	3-7
11. Spirometry test.....	3-8
12. Gas sampling line and D-fend check	3-8
13. Trend test.....	3-8
14. Watchdog test	3-8
15. Recorder test	3-8
16. Network test.....	3-9
17. Data card test.....	3-10
18. Service log check.....	3-10
19. Electrical safety check	3-10
Planned Maintenance Form	<i>End of this chapter</i>

Table of Figures

Figure 3-1. Nafion tube and filters to replace in gas unit	3-3
--	-----

3. PLANNED MAINTENANCE

3.1 Introduction

These instructions include procedures for planned maintenance (PM) of the Datex-Ohmeda Cardiocap/5 monitor. Performance of planned maintenance procedures is recommended once each year after installation of the monitor.

These instructions are for the maximum functional configuration of the monitor. Perform the procedures in order and skip items that do not correspond with the configuration of your monitor. Complete instructions on how to perform complex procedures are included in the *Service Procedures* chapter later in this manual.

3.1.1 Using the Planned Maintenance Form

A *Planned Maintenance Form* is included at the end of this chapter. Complete this “checklist” as you perform the maintenance procedures.

NOTE:  means to sign the form after performing the procedure.

3.1.2 Recommended parts

Part	Order Number
Nafion™ tube	733382
Filter (2 pieces)	886136
OM reference filter	86901
Zero absorber	895933
D-fend O-ring (2 pieces)	65312
D-fend (black)	876446
D-fend+ (green)	881319
Sampling line 3.0 m	73319
Fan filter	896113
Recorder paper (if N-XREC option is installed)	74205
Planned Maintenance Kit, <i>Anesthesia</i>	8001760
Planned Maintenance Kit, <i>Critical Care</i>	8001761

NOTE: The contents of the Planned Maintenance Kits are listed in the *Spare Parts* chapter.

3.1.3 Recommended tools and accessories

Tool	Order Number
Patient simulator for ECG, Impedance Respiration, and BP	Obtain locally
Pressure manometer	Obtain locally
Temperature test set	884515
5-lead ECG cable	Obtain locally
SpO ₂ finger sensor (compatible with the installed pulse oximetry)	Obtain locally
InvBP transducer	Obtain locally
Adult NIBP cuff	572435
Adult NIBP hose	877235
Infant NIBP cuff	877407
Infant NIBP hose	877514
Flowmeter	Obtain locally
Flow cassette 50/1.1	873812
Extra silicon tubing	Obtain locally
Calibration gas (CO ₂ , N ₂ O, O ₂ , Des)	
North America (must use with regulator 75553-01)	755571
Outside North America (must use with regulator 755533)	755583
Sampling line 3.0 m	73319
Spirometry tester	884202
Spirometry tube	884101
D-lite	733950
Screwdriver, pozidrive type	Obtain locally
Hexagon wrench, M3	Obtain locally

3.2 Planned maintenance checks

1. Visual inspection

1. Switch the monitor to standby and disconnect all cables from the rear of the monitor.
2. Check the external parts of the monitor. For example, check that the power cord receptacle is intact and the D-fend latch moves properly.
3. Check that the markings of the mains fuses correspond to the fuse plate.



2. Parts replacement

1. Dissamble the frame (see section 7.3.1).
2. Replace these items in the gas unit: occlusion filter, zero absorber, Nafion tubing, and OM reference filter. Also replace the D-fend, D-fend O-ring, and sampling line.

NOTE: Use only Datex-Ohmeda sampling lines to ensure proper function.

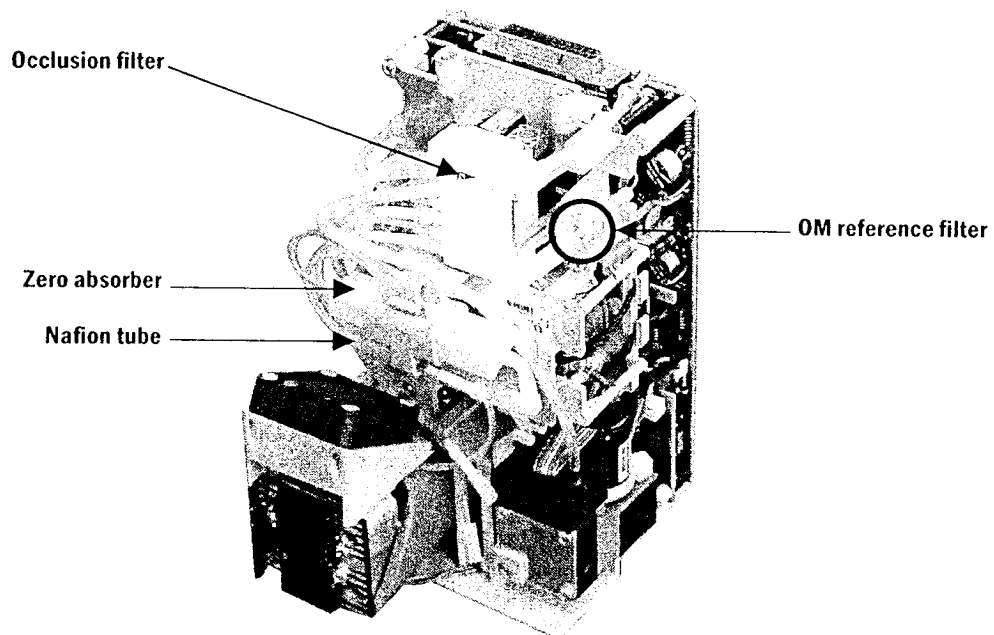

Figure 3-1. Nafion tube and filters to replace in gas unit

3. Clean or replace the fan filter.
4. Clean the recorder unit and replace the recorder paper, if necessary.
5. Reconnect all cables, then perform a gas sampling system leak test (see section 7.4.7).
6. Reassemble the frame.



3. Functional inspection

1. Connect the power cord and check that the Battery charge status LED turns on or flashes.
2. Switch on the monitor and check that it starts up as described below:
 - Both alarm LEDs flash On and Off.
 - The start-up sound is heard from the speaker.
 - The normal monitoring screen appears and no error messages are displayed.
NOTE: "Check network connectors" is displayed if the N-XNET or N-XDNET option is installed.
 - The time and date are displayed; adjust if they are incorrect.
 - The battery charging symbol is in the upper right corner of the screen:

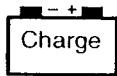

- The fan starts running after about 20 seconds.
- If the monitor contains a recorder, start-up information prints. Verify the time and date.

Enter the Keyboard service menu (illustrated in the *Service Menus* chapter) by pressing the Comwheel and selecting:

Monitor Setup

Install/Service (password 16-4-34)

Service (password 26-23-8)

Keyboard

To test the function of specific direct access keys, select **Dummy Press**.

Press the **Silence Alarms** key and check that the keypress generates a sound from the speaker and the corresponding text in the service data screen changes color. Repeat for the following keys: **Trends**, **ECG**, **NIBP**, and **Normal Screen**.

3. Go to the Monitor – Voltages service menu (return to the Service View menu and select **Monitor – Voltages**). Check that the supply voltages are within the limit values:

Voltages	Mains power ON	Mains power OFF
VDD/BAT	14.3 to 16.2	10 to 13
VIN 15VB	10 to 14.5	10 to 13.5
VDD	15.0 to 16.5	
+12V	11.4 to 12.6	
+15VD	14.25 to 15.85	
+15V	14.4 to 15.6	
-15V	15.6 to 14.4	
+2.5VREF	2.40 to 2.54	
TEMP	10 to 60	
BATVOLT	10 to 14.5	10 to 13.5
VDD/TEMP OK	0	1
CHG ON	1	0
D Sync test count	0	

4. Check the capacity time of the backup battery:

Disconnect the power cord (without switching the monitor to standby).

Note the time and make sure that the monitor continues to run normally with the battery for at least 15 minutes. The battery indicator should appear on the screen:



NOTE: You can continue the check while the monitor is powered by batteries.

5. Configure the monitor screen according to the monitor configuration so that all parameter information is displayed.

NOTE: The **Resp** parameter has to be selected in one of the **Waveform Fields** or **Digit Fields** before the respiration measurement can be turned on.



4. ECG measurement test

1. Return to the Service View menu and select **Modules – ESTP : ECG** to enter the ESTP : ECG service menu. Check that:
 - The **Timeouts**, **Bad checksums**, and **Bad c-s by mod** values are not increasing faster than 50 per second.
 - The ECG/RESP board memories passed the internal memory test (that is, **RAM**, **ROM**, and **EEPROM** all state **OK**).
2. Connect a 5-lead ECG cable to the module. Check that the **Cable type** shows **5 lead**. If it shows 3 lead, make sure the 5-lead ECG cable being used contains the necessary wiring for cable recognition (pins 0, 8, and 9 are connected together).
3. Check that each **Electrode** shows **OFF** and the “Leads Off” message is displayed.

Connect the patient simulator. Check that parameter information is displayed as configured. Check that the waveforms correspond to the simulator settings. Switch off the simulator and check that the “Asystole” and “Apnea” messages are displayed.



5. Temperature measurement test

1. Return to the Modules service menu and select **ESTP : STP** to enter the ESTP : STP service menu. Check that the STP board memories passed the internal memory test (that is, **RAM**, **ROM**, and **EEPROM** all state **OK**).
2. Check the temperature calibrations with the temperature test plugs. Calibrate if necessary.
3. Check that the protection for temperature calibration is on:
Protect key in the menu should state **OFF**. **Protect mode** should state **ON**.



6. Non-invasive blood pressure (NIBP) measurement test

NOTE: See the *Service Menus* chapter for illustrations of the service menus used for the NIBP test.

1. Return to the Modules service menu and select **NIBP** to enter the NIBP service menu. Check that NIBP board memories passed the internal memory test (**RAM**, **ROM**, and **EEPROM** all state **OK**).
2. From the NIBP service menu, select **Calibrations** to enter the Calibration service menu. Perform the **Active Leak Test** to check the NIBP tubing system for leaks: the pressure must not drop by more than 5 mmHg per minute.
3. Check the NIBP calibration with 200 mmHg pressure and calibrate if necessary.
4. Return to the NIBP service menu and select **Pneumatics** to enter the Pneumatics service menu. Check the Watchdog timer activation pressure: the audible signal must activate at 3 to 8 mmHg. If necessary, adjust the limit with the trimmer on the NIBP board and recalibrate NIBP.
5. Return to the NIBP service menu and select **Watchdog** to enter the Watchdog service menu. Check the NIBP watchdog timer.

The time for the infant test should be 60-70 seconds.

6. Return to the NIBP service menu and select **Safety Valve** to enter the Safety Valve service menu. Check the safety valve functions.

NOTE: Make sure the pressure manometer can measure pressures over 300 mmHg. If such a pressure manometer is not available, perform the check with an adult cuff that is connected around a round object, such as a calibration gas bottle.

The **Max press** and **2 s after stop** pressure values for both transducers should be within 290 to 330 mmHg for **Adult** and 154 to 165 mmHg for **Infant**.

7. Connect an infant cuff to the monitor. Start the measurement and check that the infant cuff is identified correctly. Cancel the measurement.
8. Attach an adult NIBP cuff to your arm and perform one NIBP measurement. Check that the cuff is identified correctly (for example, **Adult** briefly appears in the NIBP digit field). Check that the module gives a reasonable measurement result.



7. SpO₂ measurement test

1. Check that "No probe" is displayed when an SpO₂ sensor is not connected to the monitor. Connect an SpO₂ finger sensor to the monitor (but not to a finger). Check that "Probe off" (for standard pulse oximetry), "Check probe" (for N-XOSAT), or "Pulse search" then "Check probe" (for N-XNSAT) is displayed.
2. Attach the SpO₂ sensor to a finger and check that the pleth waveform is displayed and the SpO₂ value is in the expected range. Check that the HR value is calculated from SpO₂ when ECG and InvBP (P1/P2) cables are not connected.
3. Remove the SpO₂ sensor from your finger and check that "Probe off" (for standard pulse oximetry) or "Check probe" (for N-XOSAT or N-XNSAT) is displayed.
4. Disconnect the sensor from the monitor and check that the "No probe" message is displayed.



8. Invasive blood pressure measurement test

1. Check the InvBP channels with a patient simulator. The values and waveforms should correspond to the simulator settings.

NOTE: If you evaluate the measurement accuracy, remember to add the simulator's accuracy specification to the one of the monitor.

2. Calibrate InvBP channels if necessary.



9. Gas measurement test

NOTE: See the *Service Menus* chapter for illustrations of the service menus used for the gas measurement test.

1. Check that the fan in the gas measurement unit is running.

NOTE: If you just turned the monitor ON, you have to wait until the "Calibrating gas sensor" message disappears from the screen before entering the Gas Unit service menu.

2. Return to the Modules service menu and select **Gas Unit – General**. Check that the displayed module configuration corresponds with the configuration of the monitor.
3. Return to the Gas Unit service menu and select **Gases**. Check that the displayed **Ambient** value corresponds with the current ambient pressure (± 20 mmHg)
4. Perform a sampling system leak test.
5. Check that the flow rates are within the following ranges:

Sampling flow (ml/min) 180-220

Reference flow (ml/min) 31-45

Adjust the flow rates if necessary.

6. Perform a gas calibration.
NOTE: Do not calibrate the gas measurement until the monitor has warmed up for 30 minutes.



10. Anesthetic agent identification test

NOTE: Use only the recommended Datex-Ohmeda calibration gas (see *Recommended tools and accessories* earlier in this chapter).

While displaying the Gases service menu, feed the calibration gas continuously for at least 30 seconds and check that the screen shows:

- The **ID** is **DES**.
- The **ID unrel.** value is lower than 50.

If the value is higher, recalibrate the agent identification and check the value again.



11. Spirometry test

1. Perform the spirometry leakage test and calibration (see section 7.4.9).
2. With a sample line attached to the D-lite sensor, breathe through the wider side of the D-lite. Check that the flow waveform moves downward when you breathe in, and upward when you breathe out.



12. Gas sampling line and D-fend check

1. Block the tip of the sampling line with your finger and check that the "Sample line blocked" message is displayed on the monitor screen within 30 seconds.
2. Detach the D-fend and check that the "Check D-fend" message is displayed on the monitor screen within 30 seconds.
3. Breathe once into the sampling line and check that the response time of the CO₂ curve is normal.



13. Trend test

Check that the monitor is capable of storing the trend information and temporary settings for over 2 minutes while in standby.



14. Watchdog test

In the Watchdog Tests service menu (**Monitor – Watchdog Tests**), check that the monitor resets and restarts properly.

NOTE: Restarting should occur within a few seconds.



15. Recorder test

1. Open the paper compartment cover. Check that the "Recorder: Cover open" message appears on the screen, then close the cover.
2. Press the **Record Waveform/Stop** key on the recorder and check that the recorder starts recording the selected waveforms. Press the key again to stop recording.
3. Press the **Record Trend/Stop** key on the recorder and check that the recorder starts recording the selected trends. Press the key again to stop recording.

Check that the quality of the recording is acceptable.



16. Network test

1. Check that the Mon-Net cable connector and the Identification plug are clean and intact, then connect them to the monitor.

Check the connection to the network by checking the states of the Network connection LEDs between the connectors:

Yellow --> should flash intermittently

Green --> should be lit continuously

2. Check that the monitor connects to the Datex-Ohmeda Network (that is, the network symbol  is displayed on the upper right corner of the screen).

NOTE: If the battery is being charged, the battery charging symbol is displayed instead of the network symbol.

A message regarding the connection to the Datex-Ohmeda Information Center should appear in the message field on the screen.

3. In the Communication service menu (**Monitor – Communication**), check that:
 - ¥ The **Location ID number** matches with the ID plug connected to X3.
 - ¥ The **Packets In** and **Bytes In** are increasing slowly.
 - ¥ The **Packets Out** and **Bytes Out** are increasing fast.
 - ¥ **Connections** shows the names of the connected networks.
 - ¥ The counters for data errors (**CRC, Frame, Transm.**) are stable

NOTE: The counters may show values greater than 0 (zero), however, a continuous increase in any value indicates a problem.

4. Check that the counters for hardware errors (**Intern., Missed, FIFO, Overrun**) all show 0.



17. Data card test

1. Insert a memory card labeled "Menu" into the front-most memory card slot. Check that the "Menu card inserted" message appears in the message field.
2. Insert a memory card labeled "Data" into the second slot. Check that the "Data card inserted" message appears in the message field.
3. Check that some trend information is available in trend memory for monitored parameters. Erase the trends. Check that the trends are properly erased.

Reload the trends from the Data card. To do so, select **Patient Data – Patient from card**. Then, select the last saved file and select **Load**.

After the monitor has loaded the data, check that the trends are available again.

4. Display the Module Status service screen (**Modules – More Modules – Memory Module**) and check that:
 - **Module present** and **Module active** state **Yes**
 - **RAM, ROM, PCMCIA,** and **EEPROM** all state **OK**.
 - The **Card type** for **SLOT 1** is **MENU**.
 - The **Card type** for **SLOT 2** is **DATA**.
 - The **File system** is **ATA**.
5. Check that the rest of the information is reliable and no errors have been detected.



18. Service log check

1. Enter the Service Log menu and check for possible problems. If the monitor contains a recorder, record the service log data by selecting **Record Log**.
2. Clear the content of the service log by selecting **Reset Log**.



19. Electrical safety check

1. Perform an electrical safety check and leakage current test.
2. Check that the monitor functions normally after performing the electrical safety check.
3. Switch the monitor to standby, disconnect the power cord, and perform final cleaning.
4. Fill in all necessary documents.



Planned Maintenance Form

Datex-Ohmeda Cardiocap/5

Customer	_____		
Service	_____		
Service Engineer	_____	Date	_____

Monitor Configuration

Monitor model:	Hemodynamic model F-MX	<input type="checkbox"/>	Hemodynamic model with gas measurement F-MXG	<input type="checkbox"/>
-----------------------	---------------------------	--------------------------	---	--------------------------

Measurement options		Measurement options (SpO ₂)	
N-XP	Two invasive pressure channels and second temperature (T2)	<input type="checkbox"/>	
N-XC	CO ₂	<input type="checkbox"/>	
N-XCO	CO ₂ , N ₂ O, Patient Oxygen	<input type="checkbox"/>	
N-XCAiO	CO ₂ , anesthetic agents, agent identification, N ₂ O, Patient Oxygen	<input type="checkbox"/>	
N-XV	Patient Spirometry	<input type="checkbox"/>	
N-XNMT	NeuroMuscular Transmission (NMT)	<input type="checkbox"/>	
N-XOSAT	Datex-Ohmeda enhanced pulse oximetry	<input type="checkbox"/>	
N-XNSAT	Nellcor compatible pulse oximetry	<input type="checkbox"/>	
Data collection and data management options			
N-XREC	Recorder	<input type="checkbox"/>	
N-XNET	Network	<input type="checkbox"/>	
N-XDNET	Data card and Network	<input type="checkbox"/>	

Planned Maintenance Checks

OK = Test OK N.A. = Test not applicable Fail = Test Failed

	OK	N.A.	Fail
1. Visual inspection	<input type="checkbox"/>	<input type="checkbox"/>	<input type="checkbox"/>
2. Parts replacement (note which parts were replaced below)			
<input type="checkbox"/> Occlusion filter			
<input type="checkbox"/> Zero absorber			
<input type="checkbox"/> Nafion™ tubing			
<input type="checkbox"/> OM reference filter			
<input type="checkbox"/> D-fend			
<input type="checkbox"/> D-fend O-ring (2 pieces)			
<input type="checkbox"/> Sampling line, 3.0 m			
<input type="checkbox"/> Fan filter (optional)			
<input type="checkbox"/> Recorder paper (optional)			
<input type="checkbox"/> Other _____			

Planned Maintenance Form

	OK	N.A.	Fail
3. Functional inspection	<input type="checkbox"/>	<input type="checkbox"/>	<input type="checkbox"/>
4. ECG measurement test	<input type="checkbox"/>	<input type="checkbox"/>	<input type="checkbox"/>
5. Temperature measurement test	<input type="checkbox"/>	<input type="checkbox"/>	<input type="checkbox"/>
6. Non-invasive blood pressure (NIBP) measurement test	<input type="checkbox"/>	<input type="checkbox"/>	<input type="checkbox"/>
7. SpO ₂ measurement test	<input type="checkbox"/>	<input type="checkbox"/>	<input type="checkbox"/>
8. Invasive blood pressure measurement test	<input type="checkbox"/>	<input type="checkbox"/>	<input type="checkbox"/>
9. Gas measurement test	<input type="checkbox"/>	<input type="checkbox"/>	<input type="checkbox"/>
10. Anesthetic agent identification test	<input type="checkbox"/>	<input type="checkbox"/>	<input type="checkbox"/>
11. Spirometry test	<input type="checkbox"/>	<input type="checkbox"/>	<input type="checkbox"/>
12. Gas sampling line and D-fend check	<input type="checkbox"/>	<input type="checkbox"/>	<input type="checkbox"/>
13. Trend test	<input type="checkbox"/>	<input type="checkbox"/>	<input type="checkbox"/>
14. Watchdog test	<input type="checkbox"/>	<input type="checkbox"/>	<input type="checkbox"/>
15. Recorder test	<input type="checkbox"/>	<input type="checkbox"/>	<input type="checkbox"/>
16. Network test	<input type="checkbox"/>	<input type="checkbox"/>	<input type="checkbox"/>
17. Data card test	<input type="checkbox"/>	<input type="checkbox"/>	<input type="checkbox"/>
18. Service log check	<input type="checkbox"/>	<input type="checkbox"/>	<input type="checkbox"/>
19. Electrical safety check	<input type="checkbox"/>	<input type="checkbox"/>	<input type="checkbox"/>

Notes: _____

Signature: _____

Chapter 4. Troubleshooting

4.1	Messages.....	4-1
4.2	Troubleshooting charts	4-7
4.2.1	Start-up troubleshooting.....	4-7
4.2.2	General.....	4-8
4.2.3	ECG.....	4-8
4.2.4	Impedance respiration.....	4-9
4.2.5	Pulse oximetry (SpO ₂), standard	4-9
4.2.6	NIBP	4-9
4.2.7	Temperature	4-9
4.3	Troubleshooting charts for options	4-10
4.3.1	Recorder (N-XREC).....	4-10
4.3.2	Invasive blood pressure (N-XP)	4-10
4.3.3	Pulse oximetry (N-XOSAT or N-XNSAT)	4-11
4.3.4	Airway gases (N-XC, N-XCO, or N-XCAiO).....	4-12
4.3.5	Patient Spirometry (N-XV).....	4-13
4.3.6	NeuroMuscular Transmission (N-XNMT)	4-14

4. TROUBLESHOOTING

See the *User's Reference Manual* for more messages and troubleshooting procedures.

4.1 Messages

MESSAGE	POSSIBLE CAUSE	ACTION
Acknowl. alarms silenced	Acknowledged alarms are silenced (Silence Alarms key pressed during silencing period).	No action required.
Air leakage	Hose and/or cuff leaking. Damaged cuff, cuff connector, or hose double connector.	Replace cuff, cuff connector, and/or hose double connector.
	Hose and cuff OK, but tube disconnected or damaged.	Connect or replace tube.
	O-ring damaged or missing.	Replace O-ring.
	Leakage inside the module.	Replace the whole tubing.
	Tube disconnected or damaged; valve(s) damaged.	Fix connections. Replace tubes/valve(s).
	Air chamber leaking.	Replace the NIBP board.
Adjust	Calibration gas accepted and monitor is ready for gas value adjustments. Message may appear during calibration.	Adjust the gas values to match the calibration gas concentration.
Apnea	Respiration source is CO ₂ . Respiration waveform is normal.	Check respiration source and change it to correct one.
Apnea deactivated	Apnea alarm is silenced until reactivation after five breaths.	No action required.
Artifact(s)	Unsuccessful NIBP, SpO ₂ , or ECG measurement because of patient movements or shivering.	Stabilize or warm the patient and start a new measurement.
Back-up batt. failure	Discharged or faulty back-up battery.	Use mains power for four hours, then switch to battery power. If the message reappears, replace the battery.
Cable off	NMT or regional block cable is not connected.	Check/correct cable connections.
Calibrate Agent ID	Agent identification error.	Perform gas calibration.
Calibration failed (invasive blood pressure)	Unsuccessful calibration of P1/P2 (number field); possibly due to pulsating waveform.	Turn the transducer to sphygmomanometer and try again (zeroing takes place first).
	Gain is beyond the limits ($\pm 20\%$ of the default gain).	Replace the transducer.
Calibration not protected	NIBP calibration protection is set to OFF.	Open the NIBP Calibration menu and set Protection ON.
Calibration switch ON	EEPROM protection switch (gear wheel) accessed through hole in bottom of module is set for calibration.	Enables the Protection OFF setting in the NIBP Calibration menu. Turn the gear wheel to select Protection ON if you are not going to calibrate.

MESSAGE	POSSIBLE CAUSE	ACTION
Call service: Error X (X = the NIBP hardware error number shown in next column)	1 ROM checksum error; memory failure	Change NIBP board.
	2 + 15 V failure.	Check short circuits. Change NIBP board.
	3 - 15 V failure.	Check short circuits. Change NIBP board.
	4 EEPROM protection switch error.	Change NIBP calibration protection to OFF by turning the gear wheel and selecting Protection OFF in the NIBP Calibration menu.
	5 Calibration is not protected.	Protect NIBP calibration by selecting Protection ON in the NIBP Calibration menu.
	6 ADC error.	ADC circuit failure. Change NIBP board.
	7 Watchdog time too short.	Change NIBP board.
	8 Watchdog time too long.	Change NIBP board.
	9 Watchdog activated.	Change NIBP board.
	10 EEPROM checksum error; memory failure.	Change NIBP board.
	11 Auto zero range exceeded.	Calibrate NIBP.
	12 Communication break; temporary breakdown of communication from monitor detected.	Automatic recovery.
	14 Auto Start too early (needs 25 seconds without pressure)	Turn off the monitor. Wait longer than 25 seconds, then turn on the monitor.
	Check D-fend	Sampling line is not connected or was not connected at start-up. Water trap not attached properly. Gas outlet blocked.
Leak in the sampling line inside the measurement unit. If air leak persists, measured gas values disappear.		Check for internal air leak.
D-fend membrane is not intact.		Replace D-fend.
Gas zero valve or pump failure.		Check/replace zero valve and/or pump.
Check SpO₂ probe	No acceptable pulse is found after a 20-second pulse search; there is no detectable signal. The sensor is detached from the patient or sensor cables are not connected properly.	Check the SpO ₂ sensor application and all cable connections.
	Unsuitable site.	Try a different site.
	Faulty or wrong type of SpO ₂ sensor (sensor is not specified for use with the installed pulse oximetry).	Change the sensor. Be sure to use a sensor that is approved for use with the type of pulse oximetry installed in the monitor.
Check stim. electrodes	(NMT) stimulus current could not be delivered due to a poor stimulus electrode connection or a damaged cable.	Check electrodes. Check/replace damaged cable.
Control measurement	NIBP alarm limit was exceeded and a new measurement was started automatically.	No action required.

MESSAGE	POSSIBLE CAUSE	ACTION
Cuff loose	(NIBP) Hose and/or cuff not connected.	Connect the hose and the cuff.
	Cuff loosely wrapped.	Tighten the cuff.
	Leakage in cuff or hose.	Replace cuff/hose.
	Leakage inside module.	Check/fix internal tubing and air chamber.
	Pump does not work.	Check pump connector; if O.K., replace pump.
	No pulses during the last three measurements	Check cuff positioning.
Cuff occlusion	NIBP cuff and/or hose occlusion due to kinked cuff tube or kinked tube inside unit	Straighten tube.
	Cuff and/or hose occlusion inside/outside module.	Remove occlusion.
	Fault in pressure transducer or A/D converter.	Replace NIBP board.
	Faulty calibration.	Check calibration.
	Missing voltages.	Recalibrate.
Cuff over-pressure	NIBP cuff is squeezed during measurement and pressure safety limits are exceeded.	Stop measurement; start a new measurement.
EEPROM Error	EEPROM memory malfunction (EEPROM is on CPU board).	Perform factory reset. If the problem persists, replace the CPU board. Perform factory reset after replacing the board.
EMG electrodes off	(NMT) EMG recording electrodes are off. Electrodes or stimulus clip is loose.	Check application of electrodes and stimulus clip.
ESTP measurement removed	Signal cable is loose or not attached.	Check signal cable connections from Mother board to CPU board.
Gas measurement removed (for CO₂)	Signal cable is loose or not attached.	Check signal cable connections (Mother board to CPU board or Spirometry board to gas unit).
Leads off	One or more cables are disconnected or off the patient. This message may appear during defibrillation.	Check ECG cable, all leads, and the neutral electrode (RL/N).
Long measurement time	NIBP measurement is prolonged over the maximum measurement time (two minutes with adult or child inflation limits; one minute with infant inflation limits).	Reapply the cuff, calm the patient, and start a new measurement.
Measurement off	NMT cable is connected, but NMT measurement has not started.	No action required. Message is no longer displayed when measurement starts.
Monitor is overheating	Temperature inside monitor is above maximum limit.	Check/change the dust filter at the back of the monitor.
MVexp << MVinsp	Leak in patient circuit between patient and D-lite, or in the patient lungs, or leak in tubes from D-lite to monitor.	Check D-lite connection and D-lite tubing.
MVexp < 0.5 l/min (MVexp < 0.2 l/min with Pedi-lite)	D-lite/Pedi-lite disconnected from ventilator circuit (not shown during Apnea). Gas sampling is working correctly.	Check D-lite/Pedi-lite connections and tubing.
Network connection down	Too many monitors are active on the network.	Check/decrease number of monitors on network.

MESSAGE	POSSIBLE CAUSE	ACTION
NIBP measurement removed	Signal cable is loose or not attached.	Check signal cable connections from Mother board to CPU board.
No P1/P2 transducer	Invasive pressure or transducer cable not connected.	Connect invasive pressure or transducer cable.
No SpO₂ probe	SpO ₂ sensor is not connected to the monitor.	Check sensor connections.
	Faulty or wrong type of SpO ₂ sensor (sensor is not specified for use with the installed pulse oximetry).	Change SpO ₂ sensor. Use only sensors that are approved for use with the type of pulse oximetry installed in the monitor.
No SpO₂ pulse	Pulse search exceeded 20 seconds, low SpO ₂ , or low pulse rate. An acceptable pulse was not present for 10 seconds.	Try a different site.
Noise	High frequency or 50/60 Hz noise interfering with ECG.	Isolate source of noise.
Not zeroed (invasive blood pressure)	Measurement on, channel not zeroed.	Zero the channel.
Occlusion	See Sample line blocked .	
Poor signal	Modulation (red or infrared) < 0.25 %. Patient may be cold.	Make sure patient is not cold.
Pressure measurement removed	Signal cable is loose or not attached.	Check signal cable connections from Mother board to CPU board.
Printer error	Printer is out of paper or paper is jammed. Printer is not online or is not turned on. Printer cable is loose or broken.	Check paper, printer connections, power, and cables.
Printer failure	Printer is not responding (see Printer error).	Select/use a different printer.
Pulse search	Monitor is searching for pulse oximetry signal.	No action required.
RAM Error	RAM memory malfunction (RAM is on CPU board).	Replace the CPU board. Perform factory reset after replacing the board.
Recorder: cover open	Recorder cover open.	Close the recorder cover correctly.
Recorder: input voltage high	+12 Vrec is too high.	Check flex-strip cable and connector board.
Recorder: input voltage low	+12 Vrec is too low.	Check flex-strip cable and connector board.
Recorder: out of paper	Out of paper or paper jam.	Insert a roll of paper into the recorder or release paper jam.
Recorder: system error (1, 2, or 3)	System error.	If the problem persists, replace the recorder unit.
Recorder: thermal array overheat	Recorder overheated.	Stop using and allow recorder to cool.
Reference not stable	(NMT) The deviation between the four reference stimulation responses is too big, causing reference setting to fail. This can be caused by movement artifact and may occur when the patient is relaxed.	Check for movement.
Replace D-fend	Residue build-up on water trap membrane (decreases airflow).	Replace the D-fend.

MESSAGE	POSSIBLE CAUSE	ACTION
Response too weak	(NMT) The maximum gain is insufficient to increase the response signal amplitude to a measurable level. This can occur if: <ul style="list-style-type: none"> • Stimulation current is too weak. • Stimulation electrodes are not connected or they are improperly placed on the nerve. • Recording electrodes are disconnected. • Electrode(s) dry and should be replaced. • Skin at electrode site is improperly prepared. 	Reposition the stimulating or recording electrodes. Change the site of the measuring electrodes.
Sample line blocked	Blocked sampling line (inside or outside monitor), occluded water trap, or water trap container is full. If occlusion persists, measured gas values disappear.	Check sampling line. Check/empty water trap container. Check internal tubing for blockages.
Sensor inop.	The temperature is too high.	Check fan and filter at the front panel.
	Communication error.	Check timeout and bad checksum values at the service menu
Setting reference	(NMT) Reference search in progress.	No action required.
Small resp. curve	Respiration signal is very small.	With 3-lead cable, try another lead connection (I, II, III) or try 5-lead cable.
Snapshot memory full	Creating new snapshot will erase old one.	Cancel the selection if you do not want to erase old snapshot. Otherwise, create new snapshot.
SpO₂ probe off (probe properly attached)	Unsuitable SpO ₂ sensor site.	Try another site.
	Faulty SpO ₂ sensor.	Try another SpO ₂ sensor.
	SpO ₂ sensor cable not connected to sensor.	Connect the cable to the SpO ₂ sensor.
SRAM Error	SRAM memory malfunction (SRAM is on CPU board).	Restart the monitor. If the problem persists, replace the battery for SRAM timekeeper. Perform factory reset after replacing the battery. If message persists, replace CPU board.
Supramax not found	(NMT) Supramaximal stimulus current (70 mA) was not found.	Stop measurement, reposition the stimulating or recording electrodes, and restart measurement.
Supramax search	(NMT) Supramaximal stimulus current search in progress.	No action required.
Temperature error	Faulty calibration.	Perform calibration. If it does not help, check that front panel connectors are properly connected to STP board.
Tetanic	(NMT) Tetanic stimulation is on.	No action required.
Unable to measure Dia	Accurate diastolic pressure not achieved because of artifacts, weak pulsation, etc.	Automatic retrial with increased pressure.
Unable to measure Sys	Systolic blood pressure probably higher than the maximum inflation pressure.	Automatic retrial with increased pressure.
Unstable	Unsuccessful calibration. Message may appear during calibration.	Repeat calibration.

MESSAGE	POSSIBLE CAUSE	ACTION
Unstable zero pressure	Pressure is unstable when starting the NIBP measurement.	Calm the patient and retry.
Voltage error	Erroneous voltage level detected.	Replace power supply unit.
Weak pulsation	Weak or unstable oscillation pulses due to: <ul style="list-style-type: none"> • Marked arrhythmia; too few pulses detected; weak or unusual blood circulation. • Artifacts (accurate diastolic pressure difficult to measure) or marked drop in diastolic pressure. • Improper cuff position or attachment. NOTE: May give systolic value.	Check patient condition; check for leaks; check size of cuff and cuff attachment. Retry.
xx Zeroing error	Gas zeroing failed. Condensation or residual gases are affecting zero measurement.	Allow monitor to run drawing room air for half an hour and calibrate again.
Zero error	Unsuccessful zeroing. Message may appear during calibration.	Repeat zeroing.
Zeroing failed (invasive blood pressure)	Unsuccessful zeroing of P1/P2 (number field). Possibly due to pulsating pressure waveform.	Open the transducer to air and zero the channel.
	Offset is > 150 mmHg.	Open the transducer to air and zero the channel.
	Defective transducer.	Replace transducer and zero the channel.
... lead off	A lead wire (...) is disconnected.	Check/connect the lead wire.

4.2 Troubleshooting charts

4.2.1 Start-up troubleshooting

No picture on screen ⇓	NOTES
Check that the mains power is 100 to 240VAC.	If the mains power is too low or high the power supply does not work.
Check that the mains fuses have not blown.	Fuse type has to be T2AH.
Check that the monitor is not in the SHUT DOWN mode.	Detach the mains cord from the monitor for at least 30 seconds to reset possible SHUT DOWN mode.
OK but still no display ⇓	
Check that the green LED on front panel upper right corner is lit or flashing when the power cord is connected to mains.	This indicates that +15V VDD is coming from the AC/DC unit to the DC/DC board and the battery is charged.
OK but still no display ⇓	
Check that the alarm LEDs on front panel light after pressing the ON/STBY button.	If the LED is lit it indicates that +3.3 V and +5 V is coming from the DC/DC board to the CPU.
Alarm LEDs blank after about 20 seconds.	If the LEDs only blank for a short moment and then remain lit, the CPU software didn't start. ⇓ Try reloading new software from a PC-card
OK but still no display ⇓	
Check if the fan starts running.	If the fan does not start, the CPU is not working.
Check if the NIBP pump starts after pressing the NIBP start button.	If the NIBP pump does not start the NESTPR unit is not communicating with the CPU, or the NIBP board is broken.
OK but still no display ⇓	
The CPU and parameter units seem to be OK, the picture is missing for some other reason. Some voltages may be missing or the display is broken.	

4.2.2 General

SITUATION	POSSIBLE CAUSE	ACTION
Keyboard and ComWheel are not working	Keyboard and ComWheel cables not connected to CPU board.	Detach monitor rear cover and check the cable connections to the CPU.
	Faulty CPU.	Replace the CPU if the cable connections are OK
Keyboard is not working but the ComWheel works	Keyboard cable not properly connected to the CPU board.	Detach monitor rear cover and check the keyboard cable connection to CPU.
	Faulty key or defective CPU board.	Enter service mode and do Dummy Press keyboard test. Replace the keyboard if only a single key does not respond. Replace the CPU if more than one or two keys do not respond.
No curves in the waveform fields and no digits in the digit fields (gray fields only)	Wrong configuration set.	If the menus can be opened, enter service mode and select the configuration set according to the monitor configuration.
	SRAM back-up battery failure.	If the set configuration is lost after a short switch off period, replace the back-up battery on the CPU board. NOTE: The clock goes to 0:0 and the configuration is lost if the back-up battery fails or if the SRAM lost data for some other reason.
Some trend details do not appear.	Settings for parameter and time scales.	Adjust the parameter and time scales to see the desired trend detail.

4.2.3 ECG

SITUATION	POSSIBLE CAUSE	ACTION
HR numerical display shows '---'	No heart rate available.	If no ECG waveform, check LEADS OFF message and connect the leads. If ECG waveform exists, check heart rate source (For example, in the ECG Setup menu behind ECG key).
Unacceptable ECG waveform	Poor electrode or poor electrode skin contact.	Electrodes from different manufacturers are used/Too much/little gel is used.
	Poor electrode condition.	Electrodes are dried out.
	Improper site of electrodes.	Check that electrodes are not placed over bones, active muscles, or layers of fat.
	Improper skin preparation.	Remove body hair. Clean attachment site carefully with alcohol.
	Improper bandwidth filter.	Check filter.
No ECG trace	Waveform not selected on screen.	Adjust (Monitor Setup - Screen Setup - Waveform Fields).
	Module not plugged in correctly.	Plug in.

4.2.4 Impedance respiration

SITUATION	POSSIBLE CAUSE	ACTION
No resp trace	Waveform not selected on the screen.	Adjust (Monitor Setup – Screen Setup – Waveform Fields).
Unacceptable resp waveform	Poor electrode or poor electrode skin contact.	Electrodes from different manufacturers are used. Too much/little gel is used.
	Poor electrode condition.	Electrodes are dried out.
	Improper site of electrodes.	Check that electrodes are not placed over bones, active muscles, or layers of fat.
	Improper skin preparation.	Remove body hair. Clean attachment site carefully with alcohol.

4.2.5 Pulse oximetry (SpO₂), standard

SITUATION	POSSIBLE CAUSE	ACTION
Finger probe falls off	SpO ₂ sensor is slippery.	Check/follow the instructions for the sensor. Wipe with 70 % isopropyl alcohol and allow to dry.
	Finger is too thin or thick.	Try another finger or a different sensor.
Weak signal artifacts	Poor perfusion, movement artifacts, and/or shivering.	Try another site.
No SpO ₂	No waveform selected on screen.	Check selected SpO ₂ waveforms (Monitor Setup – Screen Setup – Waveform Fields).
	Wrong configuration setting.	Check the configuration settings in the ESTPR : STP/Calibrations menu (enter Service View menu and select Modules)

4.2.6 NIBP

SITUATION	POSSIBLE CAUSE	ACTION
No NIBP value displayed	NIBP not selected on screen.	Check monitor setup.

4.2.7 Temperature

SITUATION	POSSIBLE CAUSE	ACTION
No temperature displayed	Wrong type of probe.	Use correct probe.
	Temperature out of measurable range.	The range is between 10 and 45 °C.
	Temperature calibration not protected.	Set the protection ON in the service menu.

4.3 Troubleshooting charts for options

4.3.1 Recorder (N-XREC)

SITUATION	POSSIBLE CAUSE	ACTION
Recorder not responding to front panel key but operates through Recorder menu.	Membrane switch cable loose or broken.	Check the cable. Replace the front panel if necessary.
	Flex-strip cable broken.	Check the cable. Replace if necessary.
	Bad contact on connector board.	Check contact.
Recorder will not start. No error messages shown.	Flex-strip cable broken.	Check the cable. Replace if necessary.
	Connector board loose.	Check connector board connections.
	Recorder board faulty.	Replace the board.
	Recorder faulty.	Replace the recorder.
Recorder works but nothing appears on the paper.	Active side of paper is down.	Turn the paper roll. NOTE: To test which side is active, place the paper on a hard surface and draw a line with a fingernail. A dark line appears on the active (thermal) side.
	Faulty recorder.	Replace the recorder.

4.3.2 Invasive blood pressure (N-XP)

SITUATION	POSSIBLE CAUSE	ACTION
Abnormally low pressure	Transducer wrongly positioned.	Check mid-heart level and reposition transducer.
No pressure	Defective transducer.	Check transducer. Check that pressure transducer opens to patient.
	No pressure module plugged in.	Check the module.
	No waveform selected on screen.	Check pressure waveform selection (Monitor Setup - Screen Setup - Waveform Fields).
	Wrong configuration setting.	Check the configuration setting from the STP Calibrations service menu (enter Service View menu and select Modules - ESTP : STP - Calibrations).
Out of range	Measured pressure is beyond internal measurement range.	The waveform hits the top and the numeric display not shown. Check transducer and its level. Zero the channel.
Out of range < 40 mmHg	Measurement pressure is beyond measurement range.	Check transducer level. Zero the channel.
Out of range > 320 mmHg	Measurement pressure is beyond measurement range.	Check transducer level. Zero the channel. The patient may also have high pressure.
Zero adj. > 100 mmHg	Offset when zeroing is > 100 mmHg (but < 150 mmHg) from the unit's absolute zero (with default gain).	Check transducer. The waveform may hit the top and the numeric display not shown.

4.3.3 Pulse oximetry (N-XOSAT or N-XNSAT)

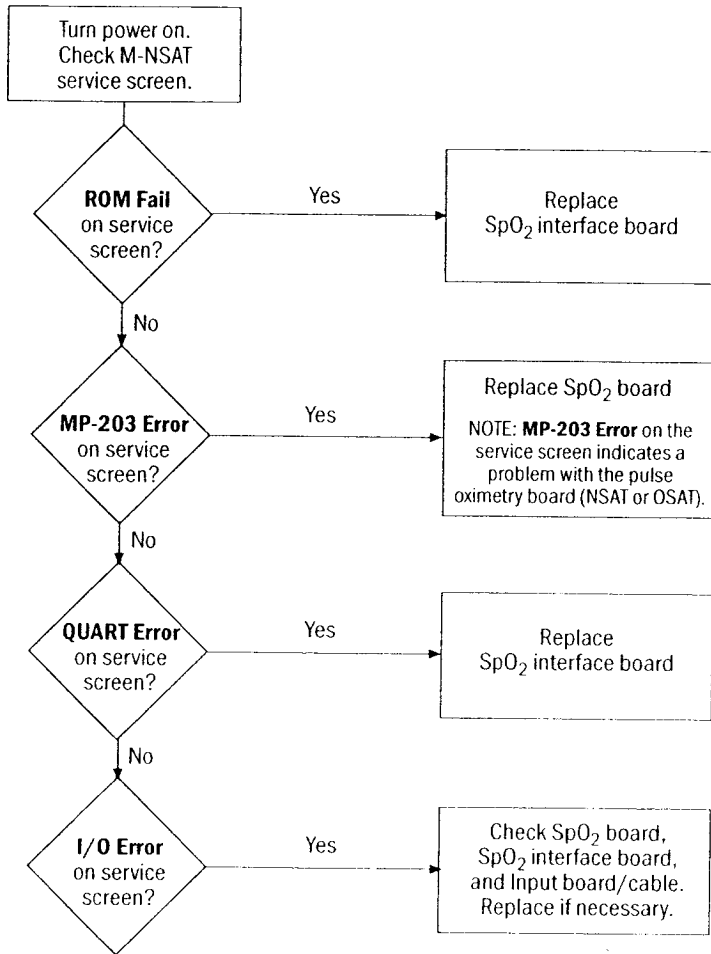

4.3.4 Airway gases (N-XC, N-XCO, or N-XCAiO)

SITUATION	POSSIBLE CAUSE	ACTION
Air leak detected.	Air leak over 40 seconds.	Check water trap and sample gas outflow. Press Normal Screen to continue.
Continuous occlusion.	Occlusion over 40 seconds.	Check sampling line and D-fend.
Gas calibration is not available during first 5 minutes/during occlusion/during air leak	Entering calibration is not allowed during 5 minutes after power up and during occlusion or air leak.	Check for occlusions or air leaks. Allow monitor to run for 30 minutes, then try again. NOTE: Calibration values must not be altered unless 30 minutes have passed after power-on.
No response to breathing	Sampling line or water trap loose, blocked, or improperly attached. Water trap container full.	Check/correct sampling line and water trap blockage and attachment. Empty water trap.
No response to any gas	Sampling line, water trap, or internal tubing blocked or loose, or improperly attached.	Check/correct sampling line, water trap, and internal tubing blockage and attachment.
	Pump failure. Occlusion or zero valve malfunction. Supply voltage missing. Serial communication error.	Enter the appropriate service menu(s) and check/verify the correct operation of the pump, valves, etc.
Sudden increase in gas display	Water trap malfunction.	Check all internal tubing and the interior of the water trap for occlusions or leaks. Replace water trap. Check flow rates.
Significant drift in all gases	Leak in sampling line or internal tubing (especially in conjunction with readings that are too low).	Check/correct leak in sampling line or internal tubing.
Abnormally high (or low) response to all gases or sudden occlusion warning	Pressure transducer failure.	Repair unit.
ETCO ₂ value too low	Leak in sampling system. Calibration error. High ventilator by-pass flow. <i>Possible clinical causes:</i> sudden circulation decrease, pulmonary embolism, very large dead-space, hyperventilation, or large shunting.	Check all connections. Check calibration.
ETCO ₂ too high	D-fend contaminated. Calibration error. <i>Possible clinical causes:</i> hypoventilation or increased metabolism.	Change D-fend. Check calibration.
Waveform clipped	Incorrect scaling.	Change scale
No response to breathing	Sampling line or water trap loose or blocked. Sample gas outlet blocked. Air leak. <i>Possible clinical cause:</i> apnea.	Check all connections. Check that outlet is open.
ETCO ₂ over scale (>15%) (not measurable)	Contaminated CO ₂ sensor. Faulty D-fend. <i>Possible clinical cause:</i> abnormally high ETCO ₂ (permissive hypercapnia).	Change D-fend.
ETCO ₂ >PaCO ₂	"Dry gas" is default. <i>Possible clinical cause:</i> unit is mmHg or kPa and ETCO ₂ is close to arterial PCO ₂ .	Change to "wet gas" by using install/service menu.

4.3.5 Patient Spirometry (N-XV)

SITUATION	POSSIBLE CAUSE	ACTION
insp TV > exp TV	<p>Spirometry tube leak.</p> <p>Water inside D-lite or tubing.</p> <p>Another side-stream gas sampling between D-lite and patient.</p> <p>D-fend leaks.</p> <p><i>Possible clinical cause:</i> leak in lungs; ET tube cuff leak.</p>	<p>Check leaks; perform leak test.</p> <p>Change tubing and D-lite.</p> <p>Don't use active humidification.</p> <p>Check D-fend. Always connect gas sampling to D-lite only.</p>
exp TV > insp TV	<p>Spirometry tube leak.</p> <p>Water inside D-lite or tubing.</p>	<p>Check leaks; perform leak test.</p> <p>Change tubing and D-lite. Don't use active humidification.</p>
PEEP > Ppeak	Spirometry tubes cross connected.	Change spirometry tubes.
Monitored volumes less than set volumes	Leak between ventilator and D-lite.	Check ventilator connections.
Loop over scale	Wrong scale selected.	Change scaling.
Strongly vibrating loop	<p>Water or secretions in hoses or D-lite.</p> <p><i>Possible clinical cause:</i> mucus in ET tube.</p>	Suction the patient. Change dry D-lite and/or empty the water from hoses.
Volumes too large or too small	Wrong mode vs. sensor selection.	Check mode and sensor (D-lite for adult; Pedi-lite for pediatric).
Fluctuating Raw	<p>Mucus in airway or tubing.</p> <p>Ventilator exp. valve causes fluctuations during exp. Flow.</p> <p><i>Possible clinical cause:</i> patient breathing effort against the ventilator; patient-triggered breaths.</p>	Check/clear airway and tubing.
Raw too high	<p>Mucus or kink in tubing.</p> <p><i>Possible clinical cause:</i> asthmatic patient or bronchospasm.</p>	Check/clear tubing.
Raw value invalid:	<i>Possible clinical cause:</i> spontaneous breaths; breathing against ventilator; patient-triggered breaths.	
Ppeak too high	<i>Possible clinical cause:</i> bronchospasm or patient is coughing; breathing against ventilator; obstructed airways or HME.	
Compl value invalid: --	<i>Possible clinical cause:</i> spontaneous breaths.	
Static PEEPi not measured	CO ₂ measurement not connected. Static PEEPi measurement not selected. Exp. pause lasted less than 4 seconds.	Connect CO ₂ meas. to D-lite. Go to spirometry setup.

4.3.6 NeuroMuscular Transmission (N-XNMT)

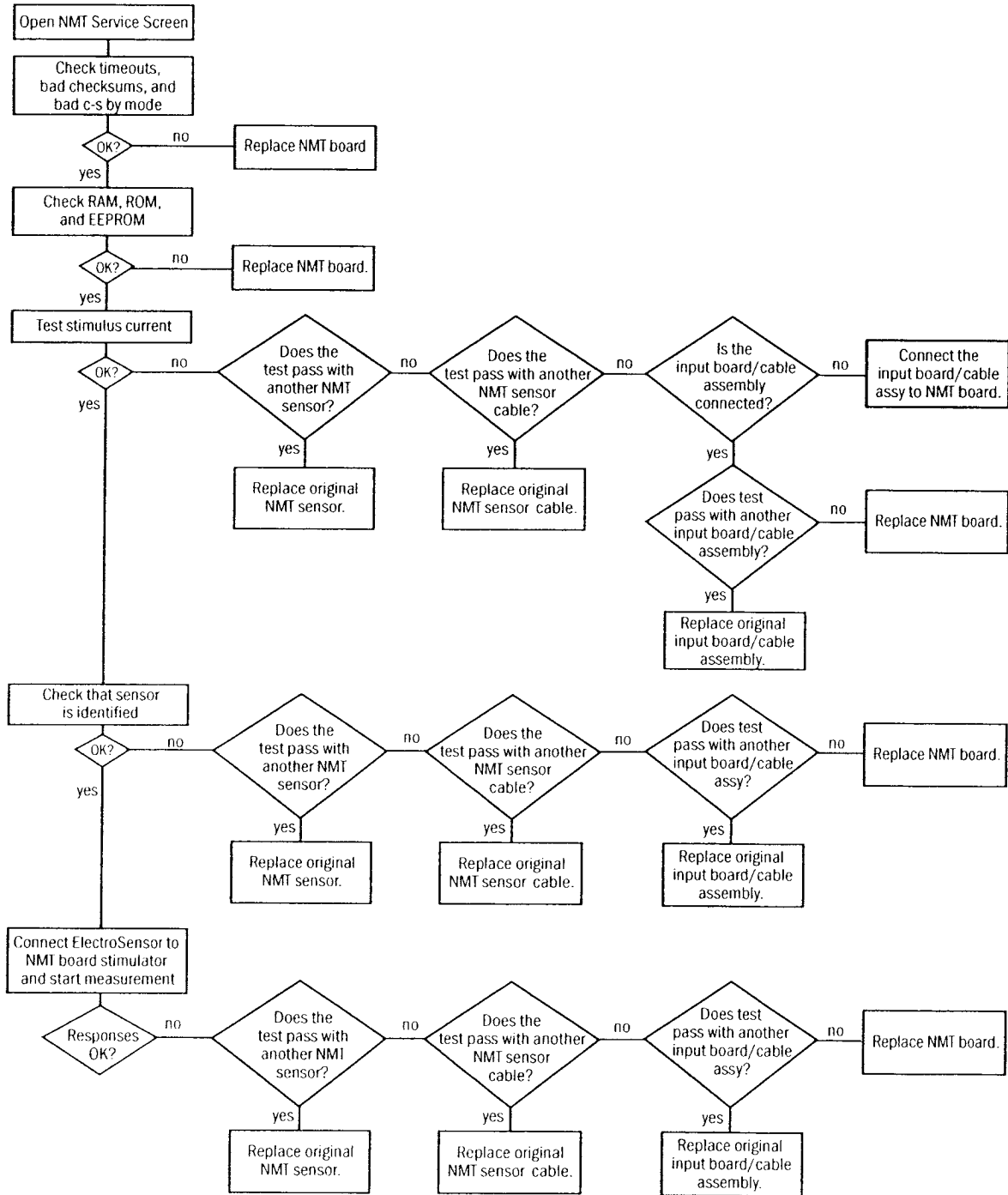

Chapter 5. Frames and Software

5.1 Introduction.....	5-1
5.1.1 Cardiocap/5 measurement options	5-1
5.2 AC/DC power supply functional description	5-2
5.2.1 Introduction	5-2
5.2.2 Main structure	5-3
5.2.3 PFC converter	5-3
5.2.4 DC/DC converter	5-4
5.2.5 Start-up sequence.....	5-4
5.2.6 Output voltage control	5-4
5.2.7 Over-voltage protection	5-5
5.2.8 Current limit	5-5
5.3 DC/DC board functional description	5-6
5.3.1 Introduction	5-6
5.3.2 DC/DC board block diagram	5-7
5.3.3 Structure of the power supply section.....	5-7
5.4 Detailed description of the power supplies	5-9
5.4.1 +3.3V power supply	5-9
5.4.2 +5V power supply	5-9
5.4.3 +12V power supply	5-9
5.4.4 +/- 15V power supply.....	5-9
5.4.5 +15VD power supply.....	5-10
+15VB boost converter.....	5-10
VDD control.....	5-10
+15VD circuit breaker.....	5-10
CPU power connector (X6)	5-11
Mother board power connector (X2).....	5-11
AC/DC power supply connector (X8).....	5-12
5.4.6 Fan control	5-12
Fan connector (X3)	5-12
5.4.7 Battery charger operating principle	5-12
Battery connector (X4)	5-13
5.4.8 Control electronics	5-13
CPU connector (X7)	5-14
5.4.9 AD converter.....	5-15
A/D channels	5-15
5.5 CPU board	5-16
5.5.1 Synchronous serial communication.....	5-18
Ethernet ID-block.....	5-18
Internal synchronous serial bus	5-18

5.5.2	Asynchronous serial channels	5-18
	Serial channels implemented with PLD (D19)	5-19
	Serial channels of the Quart	5-19
5.5.3	Keyboards and ComWheel	5-19
	Keyboard interface	5-19
	Matrix keyboard	5-19
	ComWheel	5-19
5.5.4	Digital I/O signals.....	5-20
	Defibrillator synchronization output.....	5-20
	Alarm signals.....	5-20
5.5.5	Display controller	5-21
5.5.6	Memory	5-21
	DRAM.....	5-21
	FLASH	5-21
5.5.7	PC and ethernet interfaces	5-22
	PC card	5-22
	Ethernet.....	5-22
5.5.8	Audio	5-22
5.5.9	Real-time clock and battery back-up RAM	5-22
5.5.10	Control circuit (D24)	5-22
	Supply voltage control.....	5-22
	Watchdog function.....	5-22
5.6	Display, input, and output	5-23
5.6.1	Display	5-23
5.6.2	Keyboard board	5-23
5.6.3	Mother board	5-23
5.6.4	I/O board	5-24
5.6.5	Net board	5-24
5.6.6	Parameter connector boards	5-24
5.7	Recorder and recorder board (N-XREC option)	5-25

Table of Figures

Figure 5-1.	AC/DC unit.....	5-2
Figure 5-2.	General schematic structure of SR92A720	5-3
Figure 5-3.	Inductor current waveform	5-3
Figure 5-4.	General structure of the output interfaces.....	5-4
Figure 5-5.	DC/DC board.....	5-6
Figure 5-6.	DC/DC board block diagram	5-7
Figure 5-7.	DC/DC board power supplies.....	5-8
Figure 5-8.	The CPU board.....	5-16
Figure 5-9.	Block diagram of the CPU board	5-17
Figure 5-10.	Cardiicap/5 display block diagram.....	5-23
Figure 5-11.	Built-in recorder.....	5-25

5. FRAMES AND SOFTWARE

5.1 Introduction

Two different frames, or models, are available for Cardiocap/5:

- F-MX (hemodynamic measurement)
- F-MXG (hemodynamic and gas measurement)

Anesthesia software (S-XANE) or Critical Care software (S-XCCA) is available for both frames.

5.1.1 Cardiocap/5 measurement options

The standard and optional measurement parameters that are available for each Cardiocap/5 frame are summarized below.

Parameter	F-MX	F-MXG
ECG (3-lead or 5-lead)	■	■
ST analysis	■	■
SpO ₂ and Pleth	■	■
Temperature (T1)	■	■
NIBP	■	■
Impedance respiration	■	■

Optional Parameters	F-MX	F-MXG
N-XP Two invasive pressure channels and second temperature (T2)	■	■
N-XC CO ₂	■	■
N-XCO CO ₂ , N ₂ O, Patient Oxygen	■	■
N-XCAiO CO ₂ , anesthetic agents, agent identification, N ₂ O, Patient Oxygen	■	■
N-XV Patient Spirometry NOTE: This option requires N-XCO or N-XCAiO.	■	■
N-XNMT NeuroMuscular Transmission NOTE: This option requires N-XCAiO.	■	■
N-XOSAT Datex-Ohmeda enhanced pulse oximetry	■	■
N-XNSAT Nellcor® pulse oximetry	■	■

5.2 AC/DC power supply functional description

5.2.1 Introduction

The AC/DC unit SR92A720 is a switched-mode power supply made by Efore Ltd.

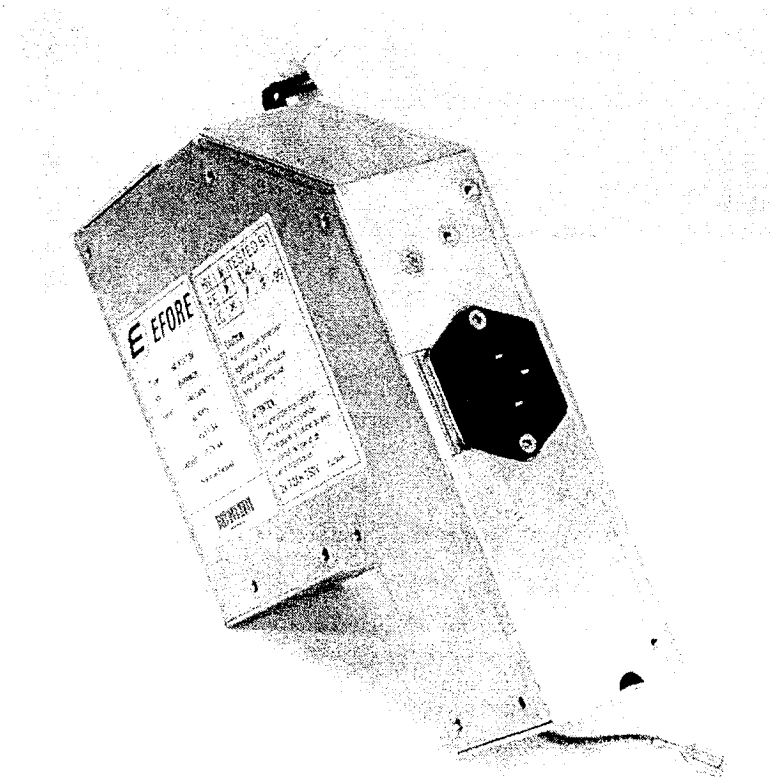

Figure 5-1. AC/DC unit

The AC/DC switched-mode power supply unit SR92A720 is an integrated part of a patient monitoring device. The SR92A720 power supply is mains connected and can be supplied with a universal single phase line voltage in the range of 85 to 275 V. The unit has one output line with a maximum continuous output power of about 63 W.

The aluminum chassis is classed as IP20. The chassis is connected to protected earth. This makes the assembly and handling of the power supply unit safer. In addition, the aluminum chassis is used in thermal management and EMC design.

5.2.2 Main structure

The general schematic structure of the SR92A720 power supply is shown below.

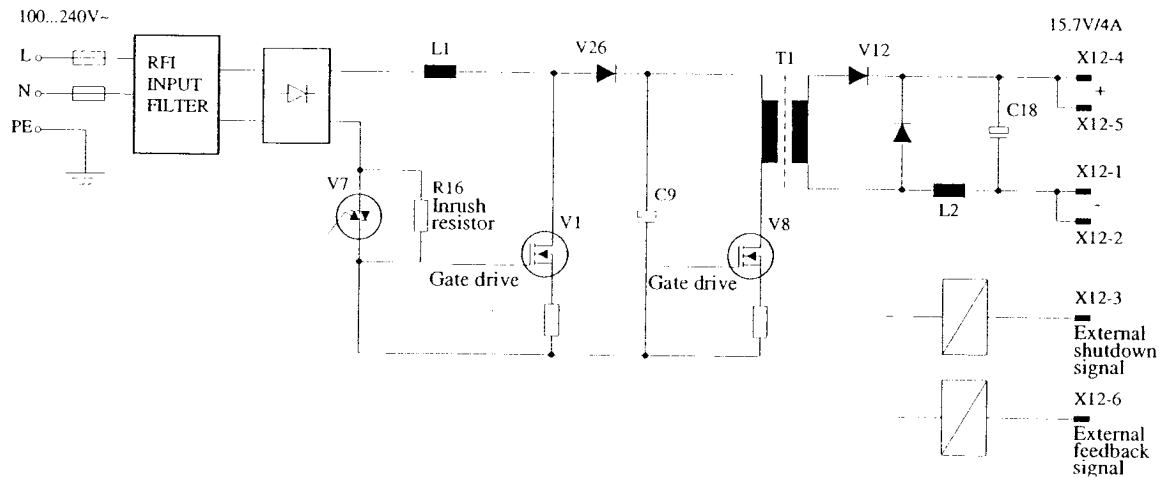

Figure 5-2. General schematic structure of SR92A720

This AC/DC converter contains two converter stages: a preconverter and a postconverter. The preconverter is an AC/DC converter which together with input low-pass filtering draws almost a sinusoidal current from the mains. As a result, input line current harmonics are reduced and the power factor is improved, therefore, this converter stage is typically also called a power factor correction (PFC) converter. This PFC converter is based on boost topology and its output voltage of about 370 V is fed to the subsequent DC/DC converter stage. The DC/DC converter uses a forward-type topology to convert the intermediate voltage of 370 V to an output voltage of 15.7 V (typical value).

5.2.3 PFC converter

The duty of the PFC converter is to reduce input line current harmonics and to improve the power factor so that the power supply meets the standards related to input current harmonics (IEC 1000-3-2 / EN 61000-3-2). The operational mode of the PFC converter is a boundary current mode. When the inductor (L1) current reaches zero level, the FET (V1) is switched on, and, therefore, the name “boundary current mode.” Respectively, when the inductor current reaches double the input line current value, the FET is switched off. The switching frequency is varying because the instantaneous rectified input line current alternates (as illustrated in the following figure).

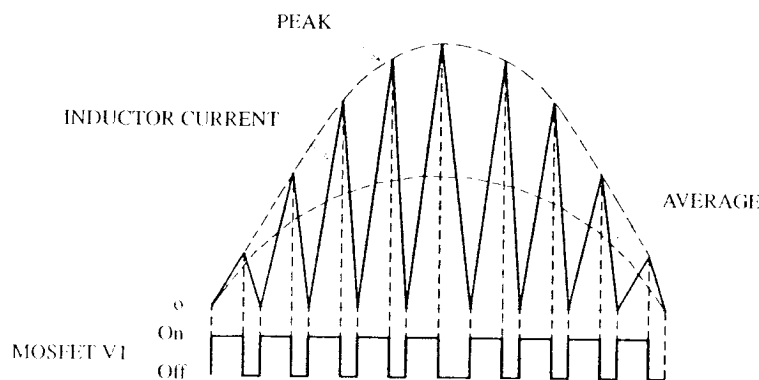

Figure 5-3. Inductor current waveform

The PFC converter controls the intermediate voltage. The intermediate voltage has been set to about 370 V. In addition, there is a small ($<10 V_{pp}$) ac ripple component across capacitor C9. The frequency of this AC component is double the line frequency.

5.2.4 DC/DC converter

The DC/DC converter is a forward converter. This converter stage converts the intermediate voltage (370 V) to the output voltage of 15.7 V (typical value). The forward converter uses a current mode control.

5.2.5 Start-up sequence

When mains voltage is connected to the input connector of the power supply, an inrush current charges the main capacitor C9. Resistor R16 limits the maximum value of this inrush current. When the voltage across capacitor C9 reaches the voltage level of about 100 V, there will be enough current flowing through resistors R80–R87 to the forward converter’s control circuit N2 to start functioning. When the forward converter is operating, it generates the supply voltage for both its own modulator IC, N₂, and for the control circuit (N1) of the PFC converter. The same supply voltage that is fed to control circuit N1 controls the triac V7. Due to this supply voltage, the gate of the triac is triggered and the triac will short circuit the inrush resistor R16. All the input current flows through the triac (negligible current through resistor R16). Due to the operation of the PFC control circuit, the voltage across capacitor C9 rises to its final value of approximately 370 V.

Also, the output voltage starts to rise when the forward converter starts to operate. The rate of the rise is limited, however, by a soft-start feature that prevents over-shoot during the start-up.

5.2.6 Output voltage control

The general structure of the output interfaces is shown below.

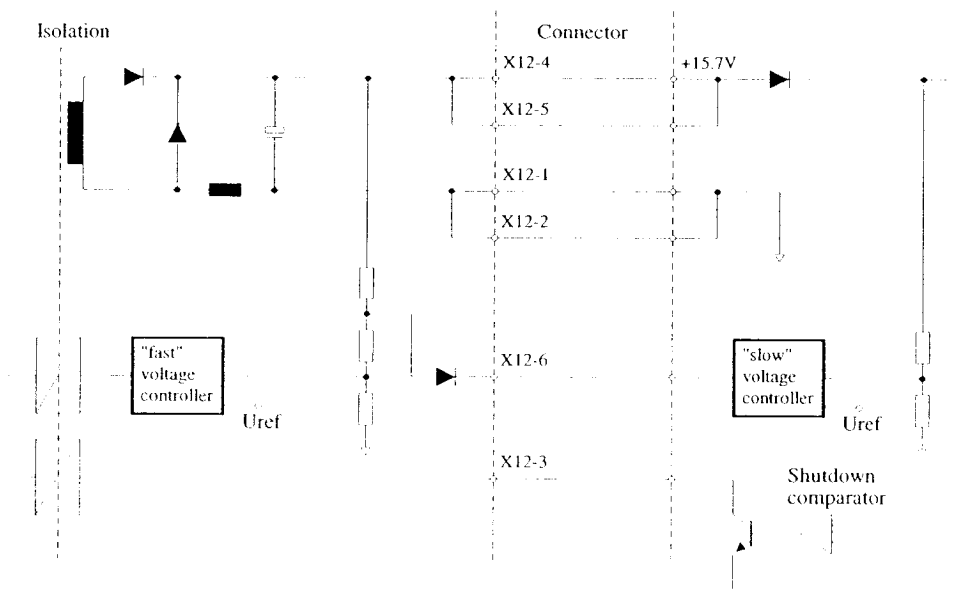

Figure 5-4. General structure of the output interfaces

Output voltage is controlled by a two-loop system. This means that there is a fast inner-voltage-control loop and a slow outer-voltage-control loop. The slow-voltage control is an external voltage signal, which, by setting the offset to the inner-control loop, determines the level of the output voltage. If the external feedback signal is not connected to pin 6 of connector X12, the output voltage measured from connector X12 settles to approximately 10 V. The external feedback signal cannot draw the output voltage lower than this 10 V level. The maximum output voltage level that the external voltage control signal can cause is set by trimmer resistor R52. Typically, the external control signal sets the output voltage to 15.7 V.

5.2.7 Over-voltage protection

The over-voltage detection circuit is not placed in the AC/DC power supply PCB (A722x). The active-low signal (open collector) is fed to pin 3 on connector X12. When this pin is pulled down, the power supply will be shut down. If the external shutdown signal is released, the SR92A720 unit will not start again even if the input line voltage is connected. Shutdown mode can be reset by removing the mains plug and then reconnecting it after at least 30 seconds.

5.2.8 Current limit

Output current limit is set to a current level of about 6 A. In case of over current, the power supply operates in a “hiccup” mode. In this mode, due to over current, supply voltage from control circuit N2 is switched off by means of transistor V25 causing a discharge of bulk capacitor C20. Capacitor C20 will be recharged by the current through resistors R80–R897. However, because the recharging time is longer than the discharging time, output current rms value is low, allowing safe operation in case of over current. The same current limiting feature protects the function and limits the output current when the output is short circuited.

5.3 DC/DC board functional description

5.3.1 Introduction

The DC/DC board converts the output voltage of the AC/DC power supply or the battery voltage to various supply voltages for the electronics of Cardiacap/5 monitor. Another main task of the board is battery charging.

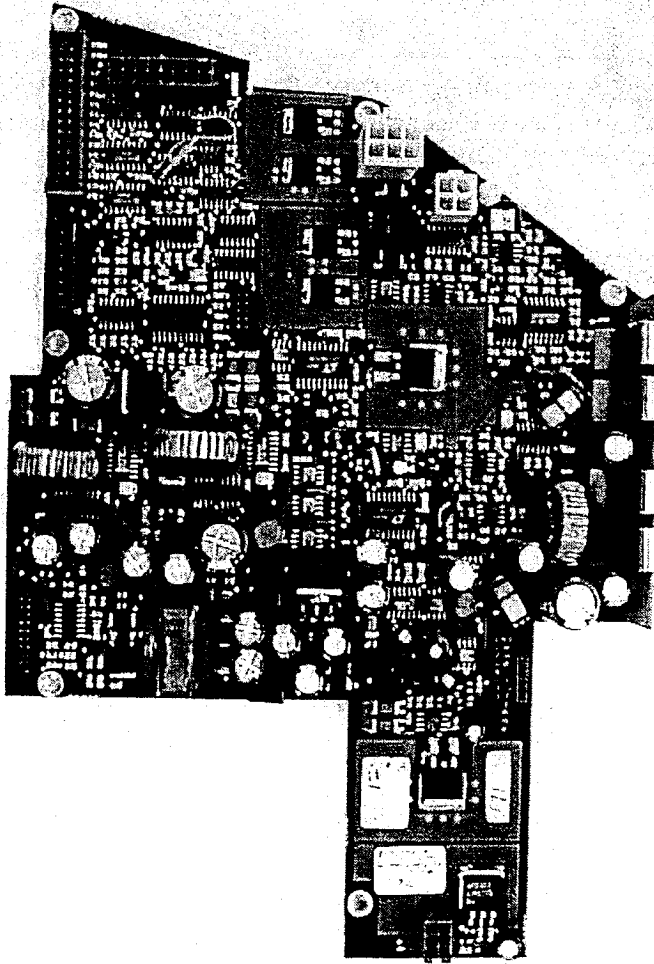

Figure 5-5. DC/DC board

5.3.2 DC/DC board block diagram

The input voltages of the board are VDD (from the AC/DC power supply) and BAT (the battery voltage). The DC/DC board trims the level of VDD. Switching power supplies convert VDD or BAT to supply voltages for monitor electronics. The board output voltages are +3.3V, +5V, +12V, +15V, -15V and +15VD.

The battery is charged when VDD is present. During mains dropouts, the monitor is powered by a 12V, sealed, lead-acid type battery.

There is no CPU chip on the DC/DC board. The main processor on the CPU board controls the power supplies' sequencing as well as switching off. An 11-channel, 12-bit A/D converter is connected to the CPU board via a slow serial-data bus.

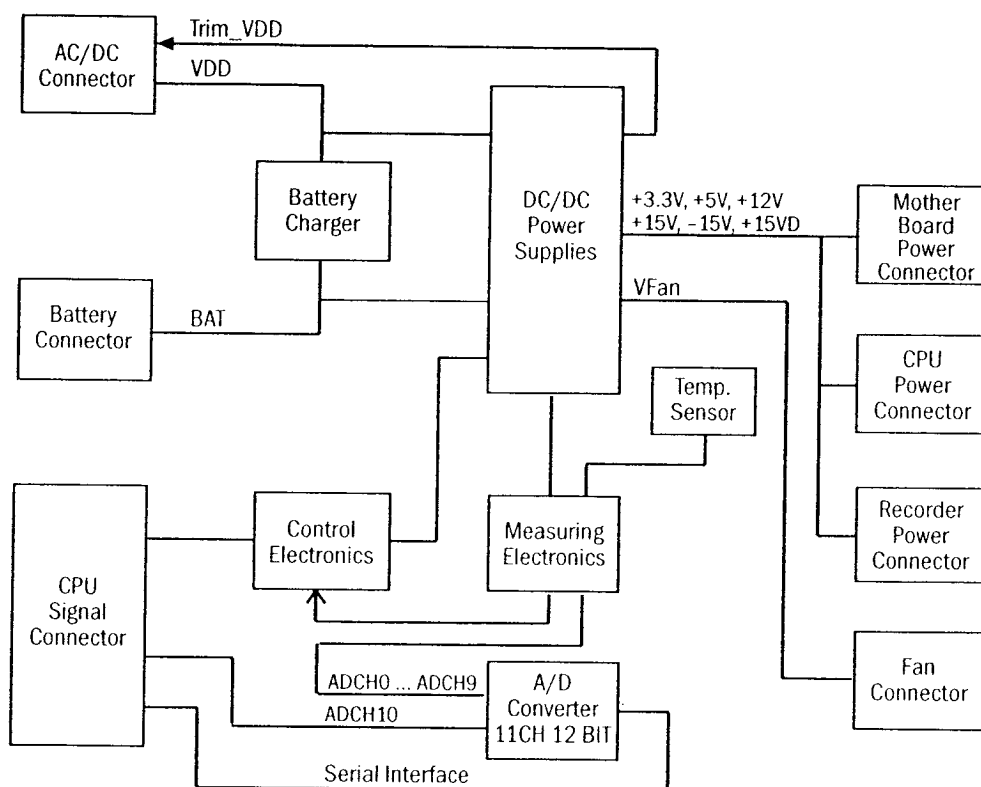

Figure 5-6. DC/DC board block diagram

5.3.3 Structure of the power supply section

The input voltages of the switching power supplies and the battery charger are connected by n-channel FETs, which are controlled by high-side driver circuits. These input switches reduce leakage current from the battery and make it possible for the CPU or control electronics to shut down a faulty power supply.

Power-on sequencing (rising order of the voltages) is controlled by the main processor. The +3.3V (the supply voltage for the CPU) is switched on first by the control electronics. +5V rises after +3.3V without CPU control. After that come other voltages. VCC_INT, +5V_INT and +2.5VREF are internal voltages of the DC/DC board.

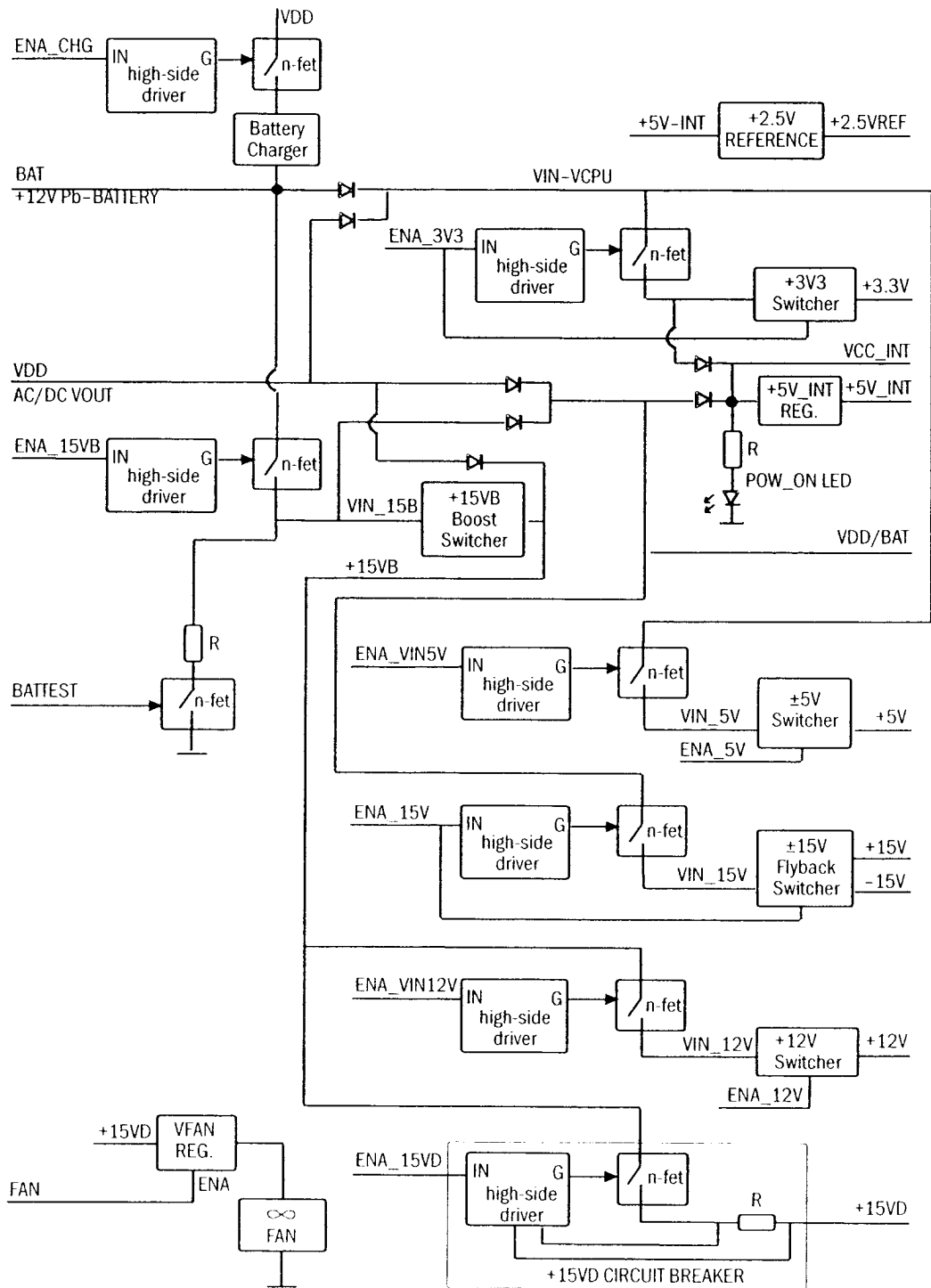

Figure 5-7. DC/DC board power supplies

5.4 Detailed description of the power supplies

Synchronous switching is used in all step-down (buck) type switching power supplies in order to improve the efficiency. In synchronous switching (or synchronous rectification), the normal schottky diode of a buck converter is bypassed by a FET conducting at the same time as the diode. This reduces diode loss remarkably.

All regulated output voltages of the DC/DC board are short-circuit protected. Protection is based on current sensing and limiting by a switcher circuit except +15VD, which is protected by a separate circuit breaker.

5.4.1 +3.3V power supply

The +3.3V switcher is a synchronous switching step-down (buck) converter. Its input voltage is taken either from VDD or battery via a diode selector. The input voltage is 10 to 16V.

The output voltage is +3.20 to +3.46V. Maximum output current is 1.8A.

5.4.2 +5V power supply

The +5V switcher is a synchronous switching step-down (buck) converter. Its input voltage is taken either from VDD or battery via a diode selector. The input voltage is 10 to 16V.

The output voltage is +4.85 to +5.25V. Maximum output current is 2.8A.

5.4.3 +12V power supply

The +12V switcher is a synchronous switching step-down (buck) converter. Its input voltage is +15VB, which is taken from VDD via a diode or directly from the boost converter. The input voltage range is 14 to 16V.

+12V switcher output voltage is +11.4 to +12.6V. Maximum output current is 1.4A.

5.4.4 +/-15V power supply

The +/-15V switcher circuit is a flyback regulator.

Input voltage for +/-15V switcher is VDD/BAT, which comes via a diode selector either from VDD or from battery. The input voltage range is 10 to 16V.

The output voltages are +14.4 to +15.6V and -15.6 to -14.4V. Both outputs can be loaded at 0.2A max.

+15V and -15V supply the analog electronics.

5.4.5 +15VD power supply

+15VD is used as a “dirty” +15V supply in the monitor. It powers the thermal printer, DC motors, pneumatic valves, and isolated switching power supplies.

On the DC/DC board, the regulated voltage is actually +15VB, which is named +15VD after circuit breaker electronics. During mains usage, +15VB is taken from VDD via a diode. When the mains voltage drops, the monitor continues operation on battery. In battery use +15VB is converted from the battery voltage by a boost type switcher. The boost converter and VDD have common control electronics. The operation is described further in the next sections.

+15VB boost converter

The input voltage range of the boost converter is 10 to 14V.

The boost converter output voltage +15VB is +14.5 to +15.4V. Maximum output current is 3.5A.

A boost converter cannot limit its short-circuit output current. To prevent the components from excessive heating in an overcurrent situation, a signal OC_15VB shuts +15VD consumption. It is also connected to the CPU to inform the CPU of exceeding the input current limit of the boost switcher. OC_15VB trip point is 6.8 to 7.9A. The output voltage will drop at a lower input-current level than that. This is meant to protect the output FET in fault condition.

VDD control

The same control circuit that adjusts +15VB boost converter also adjusts VDD when the monitor is in mains use. VDD is adjusted so that +15VB is at a little higher level than the boost regulator would regulate it at. When mains and VDD drop, +15VB falls into the lower level where the boost converter continues its regulation. To achieve adequate accuracy and to prevent the two adjustments from overlapping, the control circuits use a common reference voltage as well as a common resistor divider.

A signal TRIM_VDD is connected to AC/DC power supply to adjust VDD. VDD is increasing when TRIM_VDD is increasing. The difference between the two adjustments of +15VB is 0.2 to 0.45V, which means that +15VB is adjusted to 14.7 to 15.85V when VDD is present.

+15VD circuit breaker

To make the output voltage of the boost converter short-circuit protected, a separate circuit breaker is added on the DC/DC board. The circuit breaker consists of an n-channel FET switch, a high-side driver, and a current-measuring power resistor. When the set current limit is exceeded, the FET switches the load off. After a short period of time the driver tries to reconnect the load. If overload still exists the sequence is repeated.

The current limit is of fold-back type, which means that the trip level of the current is lower when the output voltage is near to ground. In other words, the load current must be reduced to a lower level than it was when switched off to enable reconnection. The current limit trip level is 5.1 to 7.2A. Signal OC_15VD/ becomes active when the current limit is tripped.

The FET and current measuring resistor cause a voltage drop between +15VB and +15VD. This voltage drop is allowed to be maximum 0.25V at 4A load current. +15VD voltage range is 14.25 to 15.85V at load currents 0 to 4A.

CPU power connector (X6)

PIN	SIGNAL/VOLTAGE	I/O	DESCRIPTION
X6/1	GND		
X6/2	GND		
X6/3	+3.3V	out	To CPU and 3.3V LCD display
X6/4	+3.3V	out	
X6/5	+3.3V	out	
X6/6	+3.3V	out	
X6/7	GND		
X6/8	GND		
X6/9	+5V	out	To CPU and 5V LCD display
X6/10	+5V	out	
X6/11	GND		
X6/12	GND		
X6/13	+12V	out	To LCD backlight inverter
X6/14	GND		

Mother board power connector (X2)

PIN	SIGNAL/VOLTAGE	I/O	DESCRIPTION
X2/1	VDD/BAT	out	Not utilized
X2/2	GND		
X2/3	+15VD	out	To parameter boards
X2/4	+15VD	out	
X2/5	GND		
X2/6	GND		
X2/7	+15V	out	To parameter boards
X2/8	-15V	out	To parameter boards
X2/9	GND		
X2/10	GND		
X2/11	+5V	out	To parameter boards
X2/12	+5V	out	
X2/13	+5V	out	
X2/14	+5V	out	
X2/15	GND		
X2/16	GND		

AC/DC power supply connector (X8)

PIN	SIGNAL/VOLTAGE	I/O	DESCRIPTION
X8/1	VDD_SHUTDOWN/	out	Shut AC/DC power s.
X8/2	GND		
X8/3	GND		
X8/4	TRIM_VDD	out	Adjust VDD
X8/5	VDD	in	AC/DC output voltage
X8/6	VDD	in	

5.4.6 Fan control

The supply voltage VFAN is linearly regulated from +15VD. The operating voltage range of the fan used is 10.2 to 13.8V. The fan is CPU controlled by signal FAN_ON. In the circuit used, VFAN drops to the level of 1.2 to 1.3V when FAN_ON is inactive.

Fan connector (X3)

PIN	SIGNAL/VOLTAGE	I/O	DESCRIPTION
X3/1	VFAN	out	Fan supply
X3/2	GND		

5.4.7 Battery charger operating principle

A 12V 2.6Ah sealed, lead-acid battery, with a lifetime of approximately 5 years, is used as a back-up supply. It will run the monitor for 15 minutes in case of mains dropout. It is not possible to start the monitor on battery. The battery is charged whenever VDD is present. The charger will operate without CPU control, because the CPU is out of use during monitor standby.

VDD is used as charger input voltage.

The control circuit is Unitrode UC3906, which is optimized for lead-acid batteries. The configuration used is a dual-level float charger with three charge states: a constant current bulk-charge state, a constant voltage over-charge state, and a float-charge state. A cycle begins with the charger in the bulk-charge state, sourcing the battery with a constant current I_{max} . When the battery reaches the voltage level V_{oc} , the charger goes to over-charge state. The battery voltage is kept at a constant voltage V_{oc} until the charge current has reduced to a level of $appr. I_{max}/10$ (loct). The charger enters the float-charge state, where a lower constant voltage V_{float} is supplied to the battery.

The float voltage maintains the capacity of the battery and it can be fed to the battery indefinitely. The lifetime of a lead-acid battery greatly depends on the float-voltage level. The correct level is, in turn, temperature dependent. A proper charging method requires temperature compensation of V_{float} . On the DC/DC board, the internal-reference voltage of the battery-charger circuit tracks the temperature characteristics of lead-acid cells.

If the battery voltage is below the threshold voltage (V_t) the charger enters a trickle-charge mode, where the charge current is reduced to value I_t . An overdischarged battery is charged with the trickle current (I_t) until the battery voltage reaches the level V_t above which the bulk-charge begins. The charger output short-circuit current (I_{sc}) is limited by the same resistors as the trickle current. Maximum charge current for the 12V 2,6Ah battery is 0.78A.

A CPU control signal (ICHGLOW) reduces the maximum charge current. This can be used momentarily to cut the power consumption peaks of the monitor.

Battery connector (X4)

PIN	SIGNAL/VOLTAGE	I/O	DESCRIPTION
X4/1	BAT	in	Battery voltage
X4/2	BAT	in	
X4/3	GND		
X4/4	GND		

5.4.8 Control electronics

The main functions of the control and measuring electronics are listed below:

- Buffering between CPU and DC/DC board signals.
The buffers are HCT logic to be able to accept both 5V and 3.3V logic levels in their inputs. The output is 5V cmos level.
- Power-on logic.
Pushing the on/stby switch to on position causes +3.3V and +5V supplies to rise. (+3.3V and +5V on and off sequence: +3.3V rises first and goes off last.) The CPU controls the other power supplies. Pushing the on/stby switch to standby position does not directly disable the supply voltages. The switch position information is wired also to the CPU, which controls the power supplies' switching off, also +5V and +3.3V supplies.
- Over-voltage detection.
+5V and +3.3V are rapidly pulled down by a crowbar circuitry in case of over-voltage. All the other power supplies are disabled. Over-voltage in +15VB causes VDD to be switched off by signal VDD_SHUTDOWN/. Over-voltage information goes also to the CPU by signal OV_15VB/.
- VDD detection and over-temperature detection (signal VDD/TEMP_OK).
- Monitor internal temperature measurement (signal TEMP to A/D converter).
- Battery voltage measurement (signal BATVOLT to A/D converter).
Low-battery detection. On battery use a too-low battery voltage causes all power supplies to be switched off without CPU control (HW limit). The purpose of this is to prevent the battery from overdischarging in case of CPU control malfunction.
- Switching off all power supplies in over-temperature condition by the CPU.
- Switching a power-resistor load to the battery to enable the CPU to measure approximate capacity of the battery.
- The high-charge states of the battery charger are indicated to the CPU by signal CHG_ON/.
- Controlling Cardiocap/5's front panel charge LED.
When the charger is in high-charge states (that is, not in the float charge) the LED is flashing. When in the float-charge state, the LED is continuously lit, indicating a fully charged battery. During battery use, the LED is off indicating there is no charging.

CPU connector (X7)

PIN	SIGNAL	I/O	DESCRIPTION
X7/1	ON/STBY_1	in	STBY switch end 1
X7/2	GND		STBY switch end 2
X7/3	STOP/	in	Shut +3.3V and +5V switchers
X7/4	POW_WD	in	Watchdog refresh
X7/5	EN_VIN12V	in	Enable VIN_12V
X7/6	EN_12V	in	Enable +12V
X7/7	EN_15VB	in	Enable VIN_15VB and boost conv.
X7/8	EN_15V	in	Enable +/-15V switcher
X7/9	EN_15VD	in	Enable +15VD circuit breaker
X7/10	CHG_INH	in	Disable charger input v. VCHG
X7/11	BAT_TEST	in	Connect battery test load
X7/12	VCONTRAST	in	ADCH10, scaled to 0 to 5V
X7/13	RESET/	in	+3.3V and +5V reset from CPU
X7/14	ICHGLOW	in	Reduce battery charge current
X7/15	FAN_ON	in	Enable VFAN
X7/16	OC_15VB/	out	Boost converter over-current
X7/17	OC_15VD/	out	+15VD over-current
X7/18	OV_15VB/	out	+15VB over-voltage
X7/19	CHG_ON/	out	Battery high-charge on
X7/20	CHG_LED	out	Charge LED control
X7/21	VDD/TEMP_OK	out	VDD detect / TEMP o.k.
X7/22	ADC_CS/	in	A/D converter chip select
X7/23	SSCLK	in	Serial data clock
X7/24	SSDOUT	in	Serial data in (from CPU)
X7/25	SSDIN	out	Serial data out (to CPU)
X7/26	NC_1		Not connected

5.4.9 AD converter

The analog-to-digital converter is controlled by the CPU via a slow serial data bus. The signals are SSCLK (clock), SSDOUT (CPU data out), SSDIN (CPU data in), and ADC_CS/ (chip select). The A/D converter is an 11-channel, 12-bit circuit. It uses external reference voltage. On the DC/DC board, the reference voltage is RC-filtered from +5V_INT supply. The input voltage range is 0 to +5V.

A/D channels

CHANNEL	SIGNAL/VOLTAGE	DESCRIPTION
ADCH0	VDD/BAT	
ADCH1	VIN_15VB	
ADCH2	VDD	
ADCH3	+12V	
ADCH4	+15VD	
ADCH5	+15V	
ADCH6	-15V	
ADCH7	+2.5VREF	
ADCH8	TEMP	Temperature signal
ADCH9	BATVOLT	Battery voltage signal
ADCH10	VCONTRAST	Reserved for future use

5.5 CPU board

The CPU board performs central data processing of the Cardiicap/5 monitor. The CPU board is based around an embedded AMD ELAN SC 410 (66MHz) processor. The memory chips listed below are located on the CPU board:

- 16MByte DRAM
- 8MByte Code Flash
- 8MByte Store Flash
- 2Mbyte Boot Flash
- 32kByte NV-SRAM

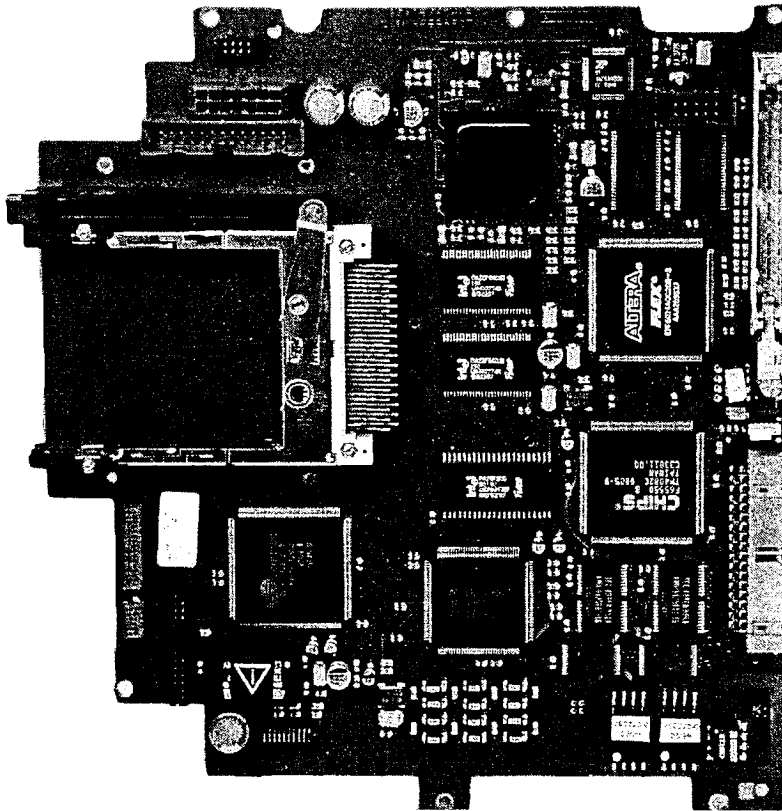

Figure 5-8. The CPU board

The CPU board manages power by controlling and monitoring the voltage levels and power consumption of the monitor. It shuts off supply voltages if over-current is detected.

The CPU board controls the Digital and Analog I/O, Serial Data interface, and Ethernet interface. In addition to the external interfaces, the CPU controls the internal Module Bus and Recorder interface. A Watchdog on the CPU board monitors the operation of the software.

The ComWheel and Matrix keyboard are directly connected to the CPU board. The Real-Time Clock, Audio generator, and Display controller are located on the CPU board. The CPU board is also equipped with two PCMCIA-compatible data-card slots for software loading and data transfer purposes.

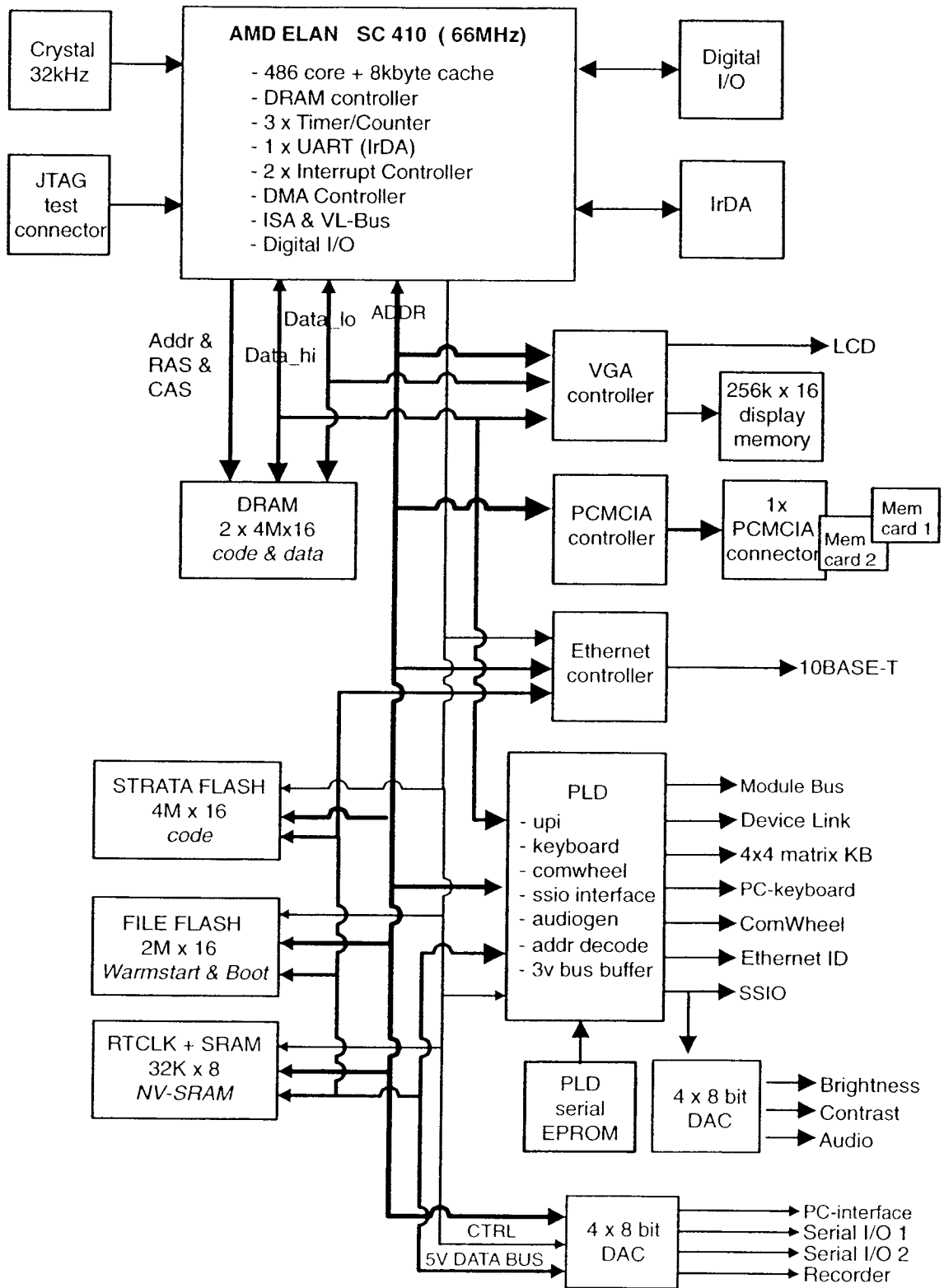

Figure 5-9. Block diagram of the CPU board

5.5.1 Synchronous serial communication

The CPU board contains two separate synchronous serial channels. Channel one handles communication with the Ethernet ID-block. Channel two is the internal serial bus of the monitor.

The synchronous serial channels are implemented with PLD to minimize the load of the main processor. Communication with the chips connected to the bus is handled by the PLD registers.

Ethernet ID-block

The Ethernet ID-block can be connected to the 9 pin D-connector on the monitor's rear panel. It contains an EPROM chip where the bedside specific ID number has been stored. The processor will read the ID number with PLD by sending the address of the memory location to the chip.

Internal synchronous serial bus

The following chips are connected to the internal synchronous serial bus:

- 8 bit x4 DAC
- 12 bit x4 DAC
- 12 bit x11 ADC

Only the 8 bit x4 DAC is located on the CPU board. It generates audio signals and controls the brightness and contrast of the display.

The 12 bit x4 DAC on the I/O board drives the Analog Output signals.

The 12 bit x11 ADC on the DC/DC board monitors the internal parameters of the monitor, such as voltages, charging currents, and temperatures.

5.5.2 Asynchronous serial channels

There are three different asynchronous serial channel groups on the CPU board:

- Serial channel implemented with PLD: Module Bus
- Serial channels of the Quart:
 - Computer Interface
 - Recorder Interface
 - Serial_I/O_1 (not in use)
 - Serial_I/O_2 (not in use)
- Serial channel integrated in Elan: Reserved for future purposes

Serial channels implemented with PLD (D19)

Module Bus

PLD and Main Software control the function of the Module Bus and the Universal Peripheral Interface (UPI). This way the interrupts generated by the serial communication will not load the main processor.

The Module Bus Reset comes from PLD pin 105.

The Module Bus is buffered to RS-485 level on the CPU board. The baud rate of the Module Bus is 500 k baud.

Serial channels of the Quart

Recorder interface

The Recorder serial interface channel uses both CTS# and RTS# handshake signals. In addition there is a reset signal for the recorder.

The Recorder serial channel has been implemented on channel D of Exar's UART ST16C654. The baud rate is 76.8 k baud.

Computer Interface

The Computer Interface serial channel is buffered to RS-232 level on the I/O board. It can be used for interfacing some external device to the monitor. The computer interface is using channel A of Exar's UART ST16C654.

Serial I/O

The channels B and C of Exar's UART ST16C654 have been reserved for future purposes. They have been wired to the I/O board connector on the CPU board.

5.5.3 Keyboards and ComWheel

Keyboard interface

An external keyboard can be connected to the monitor through the keyboard interface bus.

A PLD provides clocking for the bus and controls transmission and receipt of the messages. The keyboard interface is a synchronous serial bus. The buffering of the bus takes place on the I/O board.

Matrix keyboard

The 4x4 matrix keyboard has been implemented with a PLD. One row at a time is set active "0" and after that the state of each column is read. The state of the column is "0" if the button corresponding to that row and column is pressed.

ComWheel

Two pulse generators on the ComWheel change their states in turn when the wheel is rotated. The direction of rotation is defined by comparing the current state to the previous one. The PLD reads the state of the ComWheel and generates the I/O_INT interrupt if the state of the ComWheel has changed. The ComWheel push switch is connected to the matrix keyboard.

5.5.4 Digital I/O signals

The different I/O-signals have been split into groups according to their function:

- Defibrillator synchronization output.
- Alarm signals.
- PWR-board control signals.

Defibrillator synchronization output

Each detected QRS complex generates a 10 ms long, 5V pulse to pin 3 of the rear panel 44-pin I/O connector.

Alarm signals

In addition to audible alarms, the CPU board drives the Alarm LEDs on the monitor front panel and a NURSE_CALL signal on 44-pin I/O connector pin 5. The processor's I/O pins directly drive the Alarm LEDs. The PLD generates the NURSE_CALL signal, which is in high state when the alarm is active. In addition to the digital nurse-call signal, floating relay contacts are available on pins 11 and 12. The relay located on the I/O board connects the pins when the nurse-call signal is active.

Power supply board control signals

The control signals for the DC/DC board come directly from the processor's I/O-pins:

X5 pin	Signal name	Function
3	STOP#	Shut off +3.3V and +5V switchers
4	POW_WD	Watchdog refresh
5	EN_VIN12V	Enable VIN_12V
6	EN_12V	Enable +12V
7	EN_15VB	Enable +/- 15V circuit breaker
8	EN_15V	Enable +/- 15V switcher
9	EN_15VD	Enable +/- 15VD circuit breaker
10	CHG_INH	Disable charger input v. VCHG
11	BAT_TEST	Connect battery test load
13	PWR_RESET	+3.3V and +5V reset disables all other control signals from CPU board to power supply boards
14	ICHG_LOW	Reduce battery charge current
16	FAN_ON	Enable VFAN

The interrupts generated by the DC/DC board come directly to the processor's I/O pins:

X5 pin	Signal name	Function
16	OC_15VB#	Boost converter over-current interrupt
17	OC_15VD#	+15VD over-current interrupt
18	OV_15VB#	+15VB over-voltage interrupt
19	CHG_ON#	Battery high-charge on
21	VDD/TEMP_OK	VDD detect/Temp OK

5.5.5 Display controller

The display controller chip is a VGA-compatible chip 65550. Two 256k x 16 display memories connected to the display controller enable use of a 32-bit databus for addressing display memory. The display controller is directly connected to the VESA Local bus (VL-Bus) of the processor.

In addition to the control signals, the supply voltages (VEE_S & V_DISP) for the display are available on the display connector X7. The supply voltages for the display must be connected ON and OFF in a certain order compared to the control signals. The display-controller chip controls voltage sequencing.

Display brightness is adjusted with channel D of the 8-bit DAC. The DAC output drives the brightness-control circuit located on the Backlight board.

The voltage level for the display can be selected with jumper X14.

Jumper X14	V_DISP	Signal level
1 - 2	+5.0V	CMOS
2 - 3	+3.3V	TTL

5.5.6 Memory

DRAM

The CPU board contains two parallel 16 x 4M DRAM chips. The supply voltage for the chips is 3.3V.

When starting the monitor, the program code is loaded into the DRAM from the FLASH memory as the DRAM memory is much faster than FLASH memory, which is used as a code storage.

When switching off the monitor, the contents of the memory area reserved for the variables is copied to the FLASH memory (8Mbyte). This way the data needed for the Warm Start is easily stored.

To define if there should be Warm or Cold Start, the elapsed time since the last switch OFF is checked when the monitor is switched ON. Depending on the elapsed time, data is loaded either from the Store Flash or from the Code Flash.

An ELAN SC 410 processor generates the signals needed for controlling the DRAM chips.

FLASH

FLASH memory is used for three different purposes:

- Code Flash D10
Code Flash reserves 8 Mbyte of memory. New program can be loaded into that chip from the PCMCIA card.
- Store Flash D9
This is "Warm Start" memory used to store the contents of the DRAM memory area reserved for the variables when switching off the monitor.
- Boot Flash D9
The Boot Flash means that the uppermost block of D9 memory area is reserved for the Boot code. The contents of the Boot Flash block cannot be changed without connecting the board to the factory testing device.

5.5.7 PC and ethernet interfaces

PC card

The PC card interface, a Cirrus PCMCIA controller CL-PD6722, drives two PC cards. It is connected to the ISA bus of the processor.

The PC-Card interface accepts standard +3.3 V or +5 V cards. The controller selects the correct voltage automatically. A separate VCC and VPP switching matrix connects the voltage to the cards.

Ethernet

The Ethernet controller, a National DP83907, is connected to the ISA bus of the processor. The 10BASE-T (paired cable) Ethernet interface meets the IEEE802.3 standard.

5.5.8 Audio

Values corresponding to audio waveforms are programmed in PLD memory for generating the audio signals. The values are fed at the desired speed to a Texas 8-bit DAC converter (TLC5620).

DAC channel A generates the audio waveform and channel B adjusts the volume. The frequency range of the audio generator is 70Hz - 2500Hz.

The output amplifier is located on the I/O board.

5.5.9 Real-time clock and battery back-up RAM

An SGS-Thomson M48T35 chip containing 32k*8 RAM is used as a Real-Time Clock (RTC) on the CPU board. A lithium battery located on the chip is used to backup data stored in the RAM. The RTC integrated in the chip runs on the same battery. The battery runs the chip only in case the power supply voltage is less than 3V. The battery lifetime is approximately 10 years.

5.5.10 Control circuit (D24)

Supply voltage control

The control circuit MAX 705 watches the +3.3 V and +5 V supply voltages and resets the CPU board in case the voltages do not remain within allowed limits.

Watchdog function

The processor's I/O pin IO_CS14 is connected to the Watchdog input of MAX 705. If the state of the pin does not change at one-second intervals, the control circuit resets the board.

The purpose of the watchdog is to restart the monitor if there is a serious malfunction. This feature is necessary in two cases: 1) when the main CPU's software is not able to control the monitor and 2) when the software controls the monitor but detects a serious malfunction.

5.6 Display, input, and output

5.6.1 Display



NOTE: The LCD display backlight circuit runs on high voltage. Do not touch the inverter board when powered.

The display consists of 10.4 inch TFT LCD display unit, backlight board, and inverter board.

The CPU board drives the display. The picture data, synchronization, and +5 V supply voltage are connected from the CPU board to the display unit via the display adapter board.

The +12 V supply voltage connects to the backlight board and inverter board via the CPU board. The CPU controls the display brightness with three data bits, which adjust the backlight lamp current. The brightness data is converted to adjusting voltage on the backlight board, which controls the inverter board output and the brightness of the backlight lamps. The backlight lamps are cold cathode lamps.

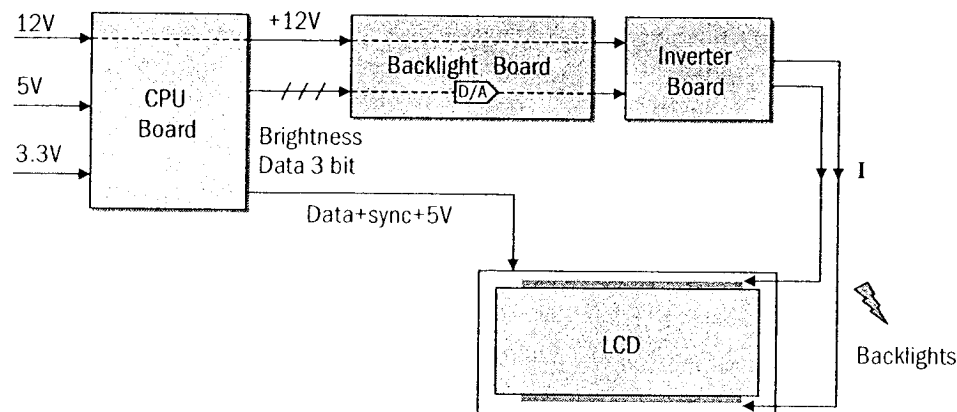

Figure 5-10. Cardiacap/5 display block diagram

5.6.2 Keyboard board

This board contains seven direct-function switches, red and yellow alarm LEDs, a green power indicator LED, and a standby switch. The standby switch is connected to the CPU and to the DC/DC board. The wire to the DC/DC board is linked through the CPU.

The power indicator LED on the board is lit constantly when VDD is available. It flashes when battery charging is active. It is connected directly to the DC/DC board.

5.6.3 Mother board

The main function of the Mother board is to connect the measuring units to the CPU and to link the supply voltages for them.

The 2.6Ah 12V back-up battery connects to the DC/DC board through the Mother board. The board contains a 10A fuse in series with the battery cable and a protection diode.

Two D25 connectors connect the airway gas and hemodynamic parameter units to the module bus. The 26-pin flat cable connector is used for expansion options. A 10-pin flat cable connector connects the module bus to the CPU board. The Mother board also provides supply voltages to the I/O board through the 16-pin Molex connector.

5.6.4 I/O board

The I/O board contains four different I/O connectors:

- 44-pin female D connector for digital/analog output.
- 9-pin male D connector for RS-232 serial I/O.
- 9-pin female D connector for connecting NET ID plug.
- 5-pin 180 DIN connector for connecting RemCo keyboard.

Data from the CPU is connected through a 40-pin flat cable connector. Power from the Mother board is connected through a 16-pin flat cable connector.

The NET function indicator LEDs are located on the board.

The audio amplifier is on the board.

A 4-channel D/A converter feeds four analog outputs.

A +5 V regulator for supplying auxiliary devices is connected to the output connector. +5 V is regulated from +15 VD.

Serial buffers convert the serial TTL data coming from the CPU to RS-232 and vice versa.

A relay connected to the analog/digital output connector (pins 11 and 12) provides a floating nurse-call signal. The digital nurse call signal coming from the CPU is on pin 5.

5.6.5 Net board

The Net board is just an adapter. The NET connector is attached on the board.

5.6.6 Parameter connector boards

Connector board	Function
Temp connector board	6.3 mm temp plug connector. Connection to the STP board.
InvBP connector board (option)	BP connectors and EMC filtering. Connection to the STP board. Two different shape of boards depending if there are gases or not.
SpO ₂ connector board	SpO ₂ connector and EMC filtering. Connection to the STP board.
ECG connector board	ECG connector, defibrillation-protection resistors, and discharge lamps.

5.7 Recorder and recorder board (N-XREC option)

You can use the optional built-in recorder to do the following:

- Record the graphical or numerical trend and print up to 24 hours of trend data.
- Record up to three real-time waveforms simultaneously.
- Display recordings of numerical information in horizontal and vertical plane.

NOTE: Thermal paper printouts may be destroyed when exposed to light, heat, alcohol, etc. Make a photocopy for your archives.

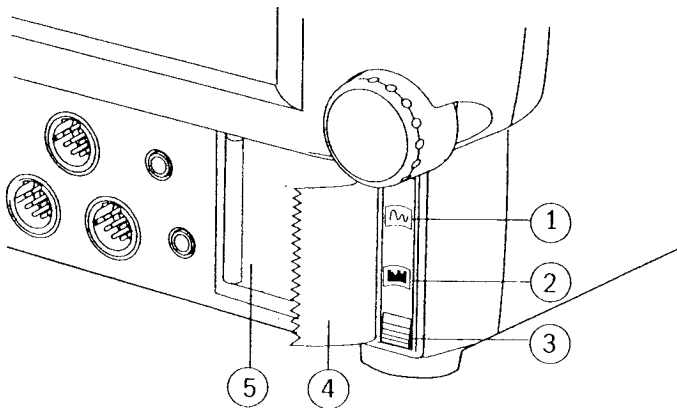

Figure 5-11. Built-in recorder

NOTE: The two-button recorder (shown) is for Cardiocap/5 monitors using software version 3.0 or higher. A one-button recorder was available previously.

- (1) **Record Waveform/Stop** key. Press to start or stop recording selected real-time waveforms. This key functions like the **Record Start/Stop** key on a one-button recorder.
- (2) **Record Trend/Stop** key. Press to start or stop recording the selected graphical or numerical trend data. Since this key is not available on a one-button recorder, use the options in the Record Trends menu (Main Menu – **Record/Print** – **Record Trends**) to print trend data.
- (3) Key to release and open the recorder paper compartment
- (4) Recorder paper
- (5) Recorder paper compartment

When the **Record Trend/Stop** key or the **Record Waveform/Stop** key on the recorder is pressed, the command to start or stop recording is transferred to the CPU through the serial bus.

The recorder board links supply voltages from the DC/DC board and data from the CPU board to the recorder. A FET circuit delays the rise. A choke and a 10,000 μ F capacitor filter the 12 V voltage. The delay limits the current peaks from the power supply.

Communication with the main CPU board takes place through +5 V CMOS-level RS232 serial interface. The recorder supply voltage of +12 VREC is switched on after +5 V is present.

Reset from the CPU bus is transferred to the recorder board.

Chapter 6. Measurement Parameters

6.1 Introduction	6-1
6.1.1 Hemodynamic parameters and related options	6-1
6.1.2 Airway gases and associated options.....	6-2
6.2 Measurement principles for hemodynamic parameters.....	6-3
6.2.1 NIBP	6-3
6.2.2 ECG	6-3
6.2.3 Impedance respiration	6-3
6.2.4 Temperature	6-3
6.2.5 Invasive blood pressure (N-XP option).....	6-4
6.2.6 Pulse oximetry, standard.....	6-4
Plethysmographic pulse wave.....	6-5
Sensor	6-5
Pulse rate	6-5
6.2.7 Pulse oximetry, Datex-Ohmeda enhanced (N-XOSAT option).....	6-5
Calibration	6-6
6.2.8 Pulse oximetry, Nellcor compatible (N-XNSAT option).....	6-7
6.3 Measurement principles for airway gases, spirometry, and NMT..	6-8
6.3.1 CO ₂ , N ₂ O, and agent measurement.....	6-8
6.3.2 O ₂ measurement.....	6-9
6.3.3 Patient spirometry measurement	6-10
Airway pressure.....	6-10
Airway flow	6-10
Compliance and airway resistance	6-11
D-lite™ flow sensor	6-11
6.3.4 NeuroMuscular Transmission (NMT) measurement	6-12
Nerve stimulation	6-12
Tetanic/Post-Tetanic Count (PTC).....	6-12
Response	6-12
Regional block	6-13
6.4 Components for NESTPR hemodynamic parameters	6-14
6.4.1 Serial communication	6-14
6.4.2 NIBP board	6-15
Pressure transducers	6-15
Signal processing.....	6-15
Software control.....	6-16
Memory	6-16
Watchdog timer.....	6-16
Valves	6-16
Power supply section.....	6-16

6.4.3	ECG board	6-17
	Analog ECG section	6-18
	ECG filtering.....	6-18
	Respiration section	6-18
	Microprocessor section.....	6-19
	Isolated section	6-19
	Power supply section.....	6-19
6.4.4	STP board	6-20
	Microprocessor unit.....	6-20
6.4.5	STP board—Pulse oximetry measurement section	6-21
6.4.6	STP board—Temperature measurement section.....	6-22
6.4.7	STP board—Invasive blood pressure measurement section.....	6-23
6.5	N-XOSAT or N-XNSAT optional pulse oximetry components.....	6-24
6.5.1	Datex-Ohmeda enhanced pulse oximetry components (N-XOSAT option).....	6-24
	Serial communications connector	6-24
	Sensor interface connector	6-24
6.5.2	Nellcor pulse oximetry components (N-XNSAT option).....	6-25
	Communication protocol jumper.....	6-25
6.5.3	SpO ₂ interface board (for N-XOSAT or N-XNSAT option).....	6-26
	RS485 drivers	6-26
	Power supply, non-isolated section.....	6-26
	Power supply, isolated section	6-26
	Opto isolation	6-27
	Microprocessor, UART, nonvolatile memory.....	6-27
	Module bus connector	6-27
	Test connector	6-27
6.6	Airway gases and spirometry components	6-28
6.6.1	Gas sampling system	6-28
6.6.2	TPX measuring unit.....	6-31
6.6.3	OM measuring unit and board	6-31
	OM board.....	6-31
6.6.4	PVX measuring unit and board (Patient Spirometry, N-XV option)	6-32
	PVX board	6-32
6.6.5	Gas unit CPU board.....	6-32
6.7	NMT components.....	6-34
6.7.1	NMT board	6-34
	Serial communication	6-34
	Stimulator.....	6-34
6.7.2	Front panel connector (NMT).....	6-35
6.7.3	Module bus connector	6-35

Table of Figures

Figure 6-1. Hemodynamic parameters measurement unit (NESTPR)	6-1
Figure 6-2. Airway gases measurement unit	6-2
Figure 6-3. Absorption of infrared light in the finger	6-4
Figure 6-4. Comparative light absorption	6-6
Figure 6-5. Extinction versus wavelength graph	6-6
Figure 6-6. TPX sensor principle	6-8
Figure 6-7. Absorbance of N ₂ O and CO ₂	6-8
Figure 6-8. Infrared absorbance of AAs	6-9
Figure 6-9. O ₂ measurement principle	6-9
Figure 6-10. Principle of response measurement	6-12
Figure 6-11. Serial communication and opto isolation	6-14
Figure 6-12. NIBP board functional block diagram	6-15
Figure 6-13. ECG board block diagram	6-17
Figure 6-14. STP board block diagram	6-20
Figure 6-15. Pulse oximetry measurement block diagram	6-21
Figure 6-16. Temperature measurement principle	6-22
Figure 6-17. Pressure measurement principle	6-23
Figure 6-18. SpO ₂ interface board block diagram	6-26
Figure 6-19. Gas sampling system (N-XC option)	6-28
Figure 6-20. Gas sampling system (N-XCO and N-XCAiO options)	6-29
Figure 6-21. Gas tubing layout	6-30
Figure 6-22. TPX measuring unit	6-31
Figure 6-23. OM measuring unit	6-31
Figure 6-24. PVX measuring unit	6-32
Figure 6-25. Signal processing	6-33
Figure 6-26. Control logic	6-33
Figure 6-27. Calibration data stored in EEPROM	6-33
Figure 6-28. NMT serial communication and opto isolation	6-34
Figure 6-29. NMT stimulator block diagram	6-34

6. MEASUREMENT PARAMETERS

6.1 Introduction

This chapter provides information about the Cardiocap/5 standard measurement features and all measurement options.

6.1.1 Hemodynamic parameters and related options

The Cardiocap/5 Parameter unit (NESTPR) provides measurement of general hemodynamic parameters.

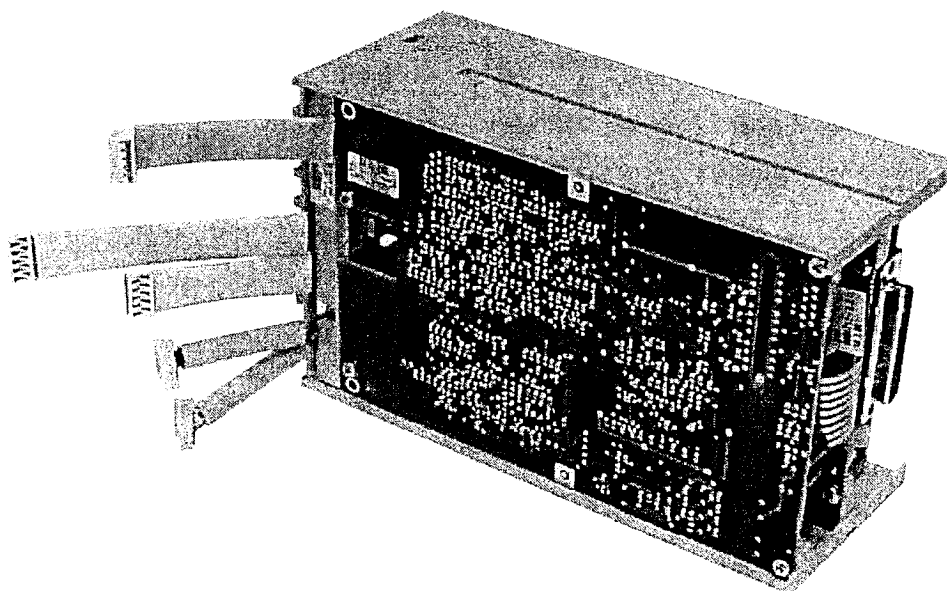

Figure 6-1. Hemodynamic parameters measurement unit (NESTPR)

NESTPR represents the measurement parameters listed below:

N = Non-invasive blood pressure (NIBP)

E = ECG

S = Pulse oximetry (oxygen saturation and pulse rate)

T = Temperature (T1)

P = Invasive blood pressure (N-XP option)—two channels (P1, P2) and a second temperature (T2)

R = Impedance respiration

The pulse oximetry options listed below require hardware and processing that is not part of the NESTPR unit:

- Datex-Ohmeda enhanced pulse oximetry (N=XOSAT option).
- Nellcor® compatible pulse oximetry (N-XNSAT option).

6.1.2 Airway gases and associated options

The Cardiicap/5 Airway Gas options (N-XC, N-XCO, N-XCAiO) provide airway and respiratory measurements through the airway gas measurement unit.

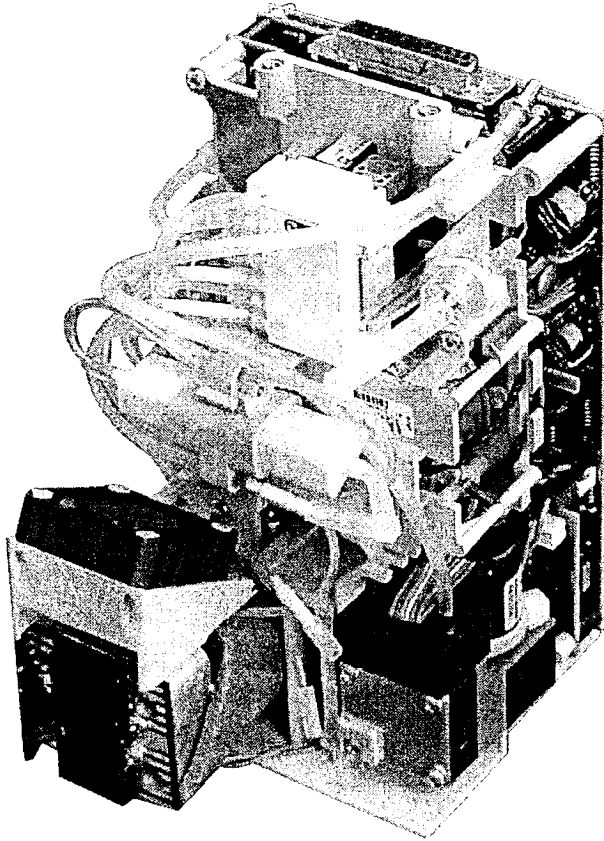

Figure 6-2. Airway gases measurement unit

The features of each option are noted in the chart below.

NOTE: One or more of the airway gas options is required for the Patient Spirometry (N-XV) and NeuroMuscular Transmission (N-XNMT) options.

Option	CO ₂	N ₂ O	O ₂	Anesthetic Agents	Anesthetic Agent id	Patient Spirometry	NeuroMuscular Transmission
N-XC	•						
N-XCO	•	•	•				
N-XCAiO	•	•	•	•	•		
N-XV *						•	
N-XNMT **							•

* Requires N-XCO or N-XCAiO.

** Requires N-XCAiO.

6.2 Measurement principles for hemodynamic parameters

6.2.1 NIBP

NIBP (Non-Invasive Blood Pressure) is an indirect method for measuring blood pressure.

The NIBP measurement is performed according to the oscillometric measuring principle. The cuff is inflated with a pressure slightly higher than the presumed systolic pressure and deflated at a speed based on the patient's pulse. Data are collected from the oscillations caused by the pulsating artery. Based on these oscillations, values for systolic, mean, and diastolic pressures are calculated.

6.2.2 ECG

Electrocardiography analyzes the electrical activity of the heart by measuring the electrical potential produced with electrodes placed on the surface of the body.

ECG reflects

- Electrical activity of the heart.
- Normal/abnormal function of the heart.
- Effects of anesthesia on heart function.
- Effects of surgery on heart function.

See the *User's Reference Manual* for electrode positions and other information.

6.2.3 Impedance respiration

Impedance respiration is measured across the thorax between three ECG electrodes. The respiration signal is made by supplying current between two electrodes and by measuring the differential current from the third electrode. The input current is 200 μ A (31 kHz). The impedance measured is the impedance change caused by breathing. When the patient is breathing or is ventilated, the volume of air in the lungs changes, resulting in impedance between the electrodes. From these impedance changes, the respiration rate is calculated and the respiration waveform is displayed on the screen.

6.2.4 Temperature

Temperature is measured by a probe whose resistance varies when the temperature changes, called NTC (Negative Temperature Coefficient) resistor.

The resistance can be measured by two complementary methods:

- Applying a constant voltage across the resistor and measuring the current that flows through it.
- Applying a constant current through the resistor and measuring the voltage that is generated across it.

The two methods are combined in the form of a voltage divider. The NTC resistor is connected in series with a normal resistor and a constant voltage is applied across them. The temperature dependent voltage can be detected at the junction of the resistors, thus producing the temperature signal from the patient. The signal is amplified by analog amplifiers and further processed by digital electronics.

6.2.5 Invasive blood pressure (N-XP option)

A catheter is inserted into an artery or vein to measure invasive blood pressure. The invasive pressure setup—consisting of tubing, a pressure transducer, and an intravenous bag of normal saline all connected together by stopcocks—is attached to the catheter. The transducer is placed level with the heart and electrically zeroed.

The transducer is a piezo-resistive device that converts the pressure signal to a voltage. The monitor interprets the voltage signal so that pressure data and pressure waveforms can be displayed.

6.2.6 Pulse oximetry, standard

NOTE: Only one pulse oximetry source at a time is allowed by the Cardiacap/5. When the N-XOSAT or N-XNSAT option is installed in the monitor, standard Cardiacap/5 pulse oximetry is not available.

A pulse oximeter measures the light absorption of blood at two wavelengths, one in the near infrared (about 900 nm) region and the other in the red region (about 660 nm) of the light spectrum. These wavelengths are emitted by LEDs in the SpO₂ sensor. The light is transmitted through peripheral tissue and is detected by a PIN diode opposite to the LEDs in the sensor. The pulse oximeter derives the oxygen saturation (SpO₂) using an empirically-determined relationship between the relative absorption at the two wavelengths and the arterial oxygen saturation, SaO₂.

To measure the arterial saturation accurately, pulse oximeters use the component of light absorption giving variations synchronous with heart beat as primary information on the arterial saturation.

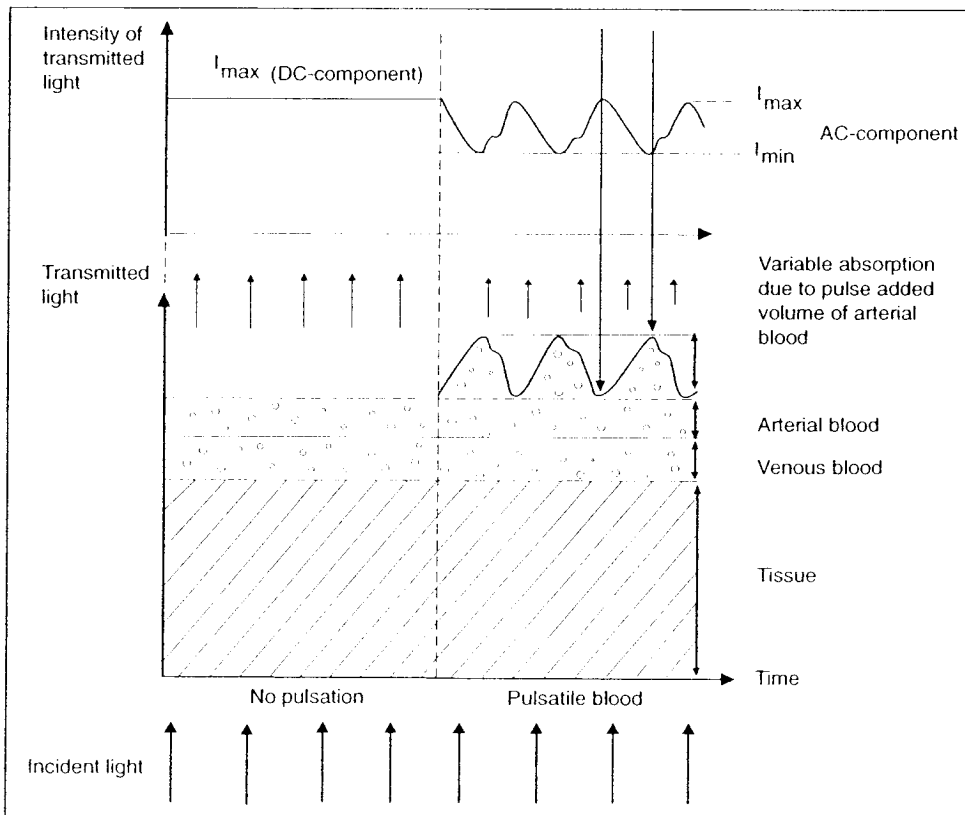

Figure 6-3. Absorption of infrared light in the finger

A general limitation of the above pulse oximetry principle is that due to the use of only two wavelengths, only two hemoglobin species can be discriminated by the measurement.

Modern pulse oximeters are empirically calibrated against fractional saturation ($SaO_2\text{frac}$) or against functional saturation ($SaO_2\text{func}$) as shown below:

$$SaO_2\text{frac} = HbO_2 / (HbO_2 + Hb + \text{Dyshemoglobin})$$

$$SaO_2\text{func} = HbO_2 / (HbO_2 + Hb).$$

Functional saturation ($SaO_2\text{func}$) is less sensitive to changes of carboxyhemoglobin and methemoglobin concentrations in blood.

The oxygen saturation percentage SpO_2 is calibrated against the functional saturation ($SaO_2\text{func}$). The advantage of this method is that the accuracy of SpO_2 measurement relative to $SaO_2\text{func}$ can be maintained even at rather high concentrations of carboxyhemoglobin in blood. Independent of the calibration method, a pulse oximeter is not able to correctly measure oxygen content of the arterial blood at elevated carboxyhemoglobin or methemoglobin levels.

Plethysmographic pulse wave

The plethysmographic waveform is derived from the IR signal and reflects the blood pulsation at the measuring site. Thus the amplitude of the waveform represents the perfusion.

Sensor

SpO_2 sensors contain the light source LEDs, which are located opposite the photodiode detector. Different kinds of sensors are available from Datex-Ohmeda, including clip-on and wrap styles.

Pulse rate

The pulse rate calculation is done by peak detection of the plethysmographic pulse wave. The signals are filtered to reduce noise and checked to separate artifacts.

6.2.7 Pulse oximetry, Datex-Ohmeda enhanced (N-XOSAT option)

NOTE: Only one pulse oximetry source at a time is allowed by the Cardiocap/5. When the N-XOSAT option is installed in the monitor, standard pulse oximetry and N-XNSAT are not available.

The Datex-Ohmeda enhanced pulse oximetry option uses a two-wavelength pulsatile system—red and infrared light—to distinguish between oxygenated (O_2Hb) and reduced (HHb) hemoglobin, each of which absorbs different amounts of light emitted from the oximeter sensor. The SpO_2 and pulse rate are determined by the oximeter through sensor signal processing and microprocessor calculations.

The SpO_2 sensor contains a light source and a photodetector:

- The light source consists of red and infrared light-emitting diodes (LEDs).
- The photodetector is an electronic device that produces an electrical current proportional to incident light intensity.

The two light wavelengths generated by the sensor light source (the red and infrared LEDs) pass through the tissue at the sensor site. The light is partially absorbed and modulated as it passes through the tissue.

Arterial blood pulsation at the sensor site modulates transmission of the sensor's light. Since other fluids and tissues present generally don't pulsate, they don't modulate the light passing through that location. The pulsatile portion of the incoming signal is used to detect and isolate the attenuation of light energy due to arterial blood flow.

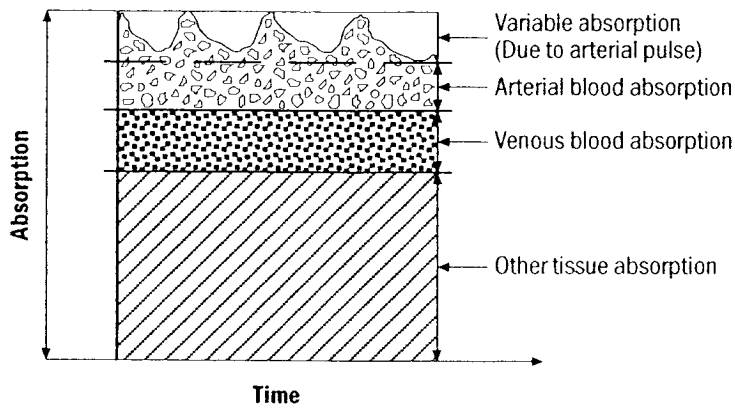

Figure 6-4. Comparative light absorption

The sensor's photodetector collects and converts the light into an electronic signal. Since O_2Hb and HHb allow different amounts of light to reach the photodetector at the selected wavelengths, the electronic signal varies according to which light source is "on" (red or infrared) and the oxygenation of the arterial hemoglobin. The oximeter uses this information to calculate the relative percentage of O_2Hb and HHb .

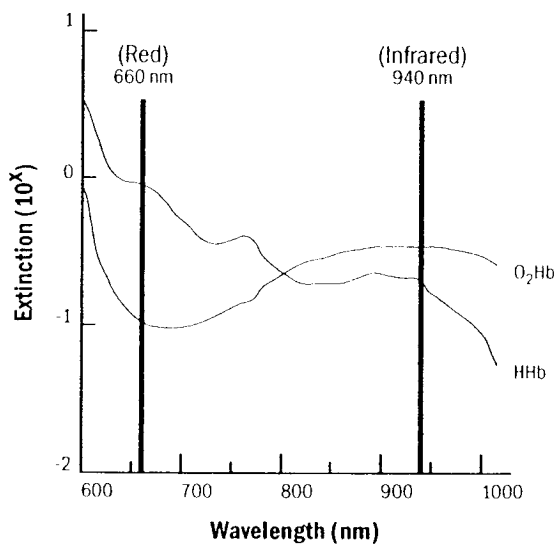

Figure 6-5. Extinction versus wavelength graph

The photodetector sends the electronic signal, which contains the light intensity information, to the oximeter. The oximeter's electronic circuitry processes the electronic signal, calculates the SpO_2 and pulse rate values, and displays them on the screen.

Calibration

Datex-Ohmeda enhanced pulse oximetry uses two wavelength ranges, 650 nm to 665 nm and 930 nm to 950 nm, both with an average power of less than 1 mW. These wavelengths are used to calculate the presence of oxyhemoglobin (O_2Hb) and reduced hemoglobin (HHb).

A CO-oximeter typically uses four or more wavelengths of light and calculates reduced hemoglobin (HHb), oxyhemoglobin (O₂Hb), carboxyhemoglobin (COHb), and methemoglobin (MetHb). Therefore, pulse oximetry readings and CO-oximetry readings will differ in situations where a patient's COHb or MetHb are increased. Increased patient COHb leads to falsely increased SpO₂ in all pulse oximeters.

Datex-Ohmeda enhanced pulse oximetry uses functional calibration, which is represented mathematically as the percentage of hemoglobin capable of carrying oxygen that is carrying oxygen.

$$\text{Functional SpO}_2 = \left(\frac{\text{O}_2\text{Hb}}{\text{Hb}_{\text{TOTAL}} - \text{COHb} - \text{MetHb}} \right) \times 100 = \left(\frac{\text{O}_2\text{Hb}}{\text{O}_2\text{Hb} + \text{HHb}} \right) \times 100$$

The calculation of SpO₂ assumes 1.6% carboxyhemoglobin (COHb), 0.4% methemoglobin (MetHb), and no other pigments. These values are based on the Datex-Ohmeda Pulse Oximeter Empirical Calibration Study. Appreciable variation from these values will influence SpO₂ accuracy.

6.2.8 Pulse oximetry, Nellcor compatible (N-XNSAT option)

NOTE: Only one pulse oximetry source at a time is allowed by the CardiCap/5. When the N-XNSAT option is installed in the monitor, standard pulse oximetry and N-XOSAT are not available.

The N-XNSAT pulse oximetry option uses the Nellcor pulse oximetry algorithm and should be used with Nellcor pulse oximetry sensors only. Refer to the *CardiCap/5 User's Reference Manual* for a list of Nellcor sensors approved for use with this option.

6.3 Measurement principles for airway gases, spirometry, and NMT

6.3.1 CO₂, N₂O, and agent measurement

TPX is a side-stream gas analyzer that measures real-time concentrations of CO₂, N₂O and anesthetic agents (Halothane, Enflurane, Isoflurane, Desflurane, and Sevoflurane). The TPX analyzer identifies anesthetic agents or mixtures of two anesthetic agents and measures their concentrations. It also detects mixtures of more than two agents and issues an alarm.

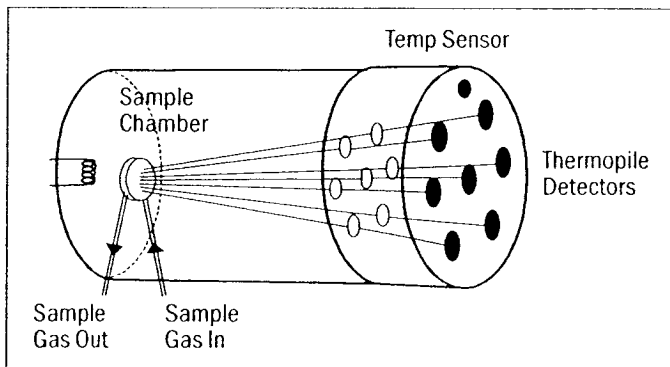

Figure 6-6. TPX sensor principle

TPX is a nondispersive infrared analyzer that measures absorption of the gas sample at seven infrared wavelengths that are selected using optical narrow band filters.

The infrared radiation detectors are thermopiles.

Concentrations of CO₂ and N₂O are calculated from absorption measured at 3 to 5 μm.

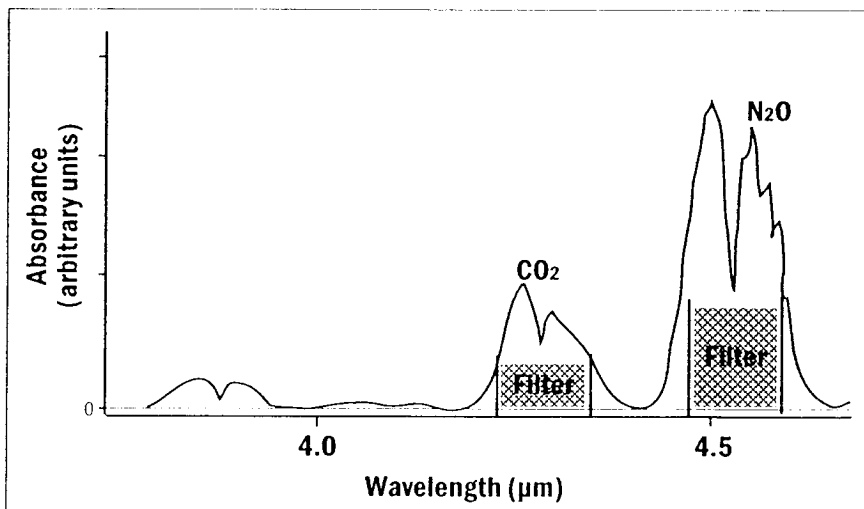

Figure 6-7. Absorbance of N₂O and CO₂

Identification of anesthetic agents and calculation of their concentrations is performed by measuring absorptions at five wavelengths in the 8 to 9 μm band, then using a set of five equations to solve the concentrations.

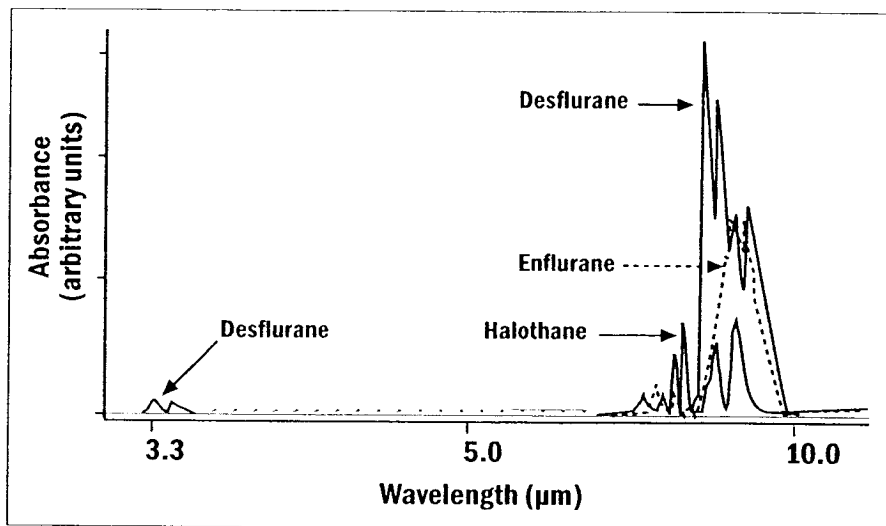

Figure 6-8. Infrared absorbance of AAs

To achieve measuring accuracy, numerous software compensation parameters are individually determined for each TPX during factory calibration.

6.3.2 O₂ measurement

The differential oxygen measuring unit uses the paramagnetic principle in a pneumatic bridge configuration. The signal picked up with a differential pressure transducer is generated in a measuring cell with a strong magnetic field that is switched on and off at a frequency of 165 Hz. The output signal is a DC voltage proportional to the difference in O₂ concentration between the two gases to be measured.

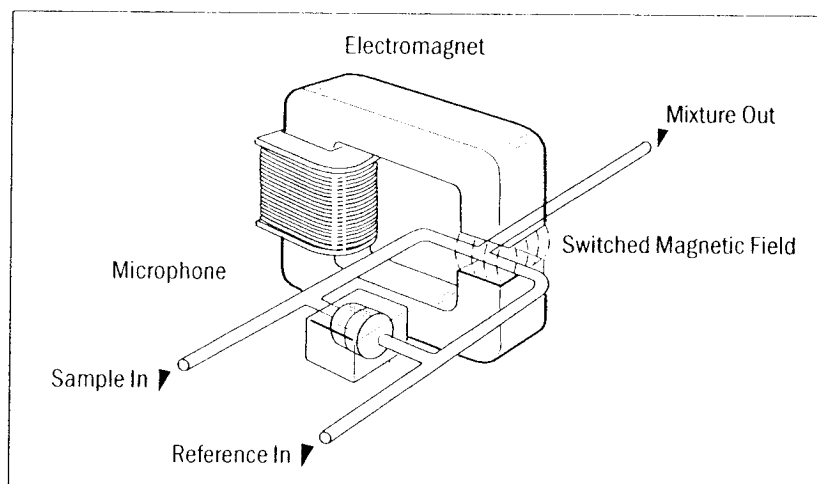

Figure 6-9. O₂ measurement principle

6.3.3 Patient spirometry measurement

In mechanical ventilation, breaths are delivered to the patient by a ventilator with a proper tidal volume, respiration rate (RR), and inspiration/expiration ratio in a time determined by the ventilator settings.

Patient Spirometry monitors patient ventilation and displays these parameters:

- Expiratory and inspiratory tidal volume (TV) in ml
- Expiratory and inspiratory minute volume (MV) in l/minute
- Expiratory spontaneous minute volume in l/minute
- Expiratory volume in first second (V1.0) in percent (%)
- Inspiration/expiration ratio (I:E)

Airway pressure

- Peak pressure (P_{peak})
- Mean airway pressure (P_{mean})—Critical care software only
- End inspiratory pressure (P_{plat})
- PEEPi, PEEPe—Critical care software only
NOTE: PEEPi = intrinsic PEEP, PEEP-PEEPe
- Positive end expiratory pressure (PEEP)—Anesthesia software only
- Real time airway pressure waveform (P_{aw})

PEEP, P_{peak} , P_{mean} , and P_{plat} are measured by a pressure transducer on the PVX board. Atmospheric pressure is used as a reference. The pressure measurement is made from the airway part that is closest to the patient between the patient circuit and the intubation tube.

Airway flow

- Real time flow waveform (V')
- Compliance (Compl)
- Airway resistance (R_{aw})
- Pressure volume loop
- Flow volume loop

The kinetic gas pressure is measured using the Pitot effect. A pressure transducer measures the Pitot pressure. The obtained pressure signal is linearized and corrected according to the density of the gas. Flow speed is calculated from these pressure values, then the tidal volume (TV) value is integrated. The minute volume (MV) value is calculated and averaged using the TV and respiratory rate values.

Compliance and airway resistance

Compliance tells how big a pressure difference is needed to deliver a certain amount of gas into the patient. Compliance is calculated for each breath from the following equation:

$$Compl = \frac{TVexp}{P_{plat} - PEEP_i - PEEP_e}$$

The airway resistance, R_{aw} , is calculated using an equation that describes the kinetics of the gas flow between the lungs and the D-lite flow sensor. The equation states that the pressure at the D-lite can at any moment of the breath be approximated using the equation

$$p(t) = R_{aw} \cdot V'(t) + V(t) / Compl + PEEP$$

where $p(t)$, $V'(t)$ and $V(t)$ are the pressure, flow and volume measured at the D-lite at a time (t) , R_{aw} is the airway resistance, $Compl$ is the compliance, and $PEEP$ is the total end-expiratory pressure.

D-lite™ flow sensor

Patient Spirometry uses a D-lite flow sensor. The adult D-lite sensor measures adults; the pediatric measures children. Single-use and reusable versions of these sensors are available.

The D-lite adapter measures kinetic pressure by a two-sided Pitot tube. Velocity is calculated from the pressure difference according to Bernoulli's equation:

$$v = \sqrt{\frac{2 \times dP}{\rho}}$$

where: v = velocity (m/second), dP = pressure difference (cmH₂O), and ρ = density (kg/m³)

Flow is then determined using the calculated velocity:

$$F = v \times A$$

where: F = flow (l/minute), v = velocity (m/second), and A = cross area (m²)

The volume information is obtained by integrating the flow signal.

6.3.4 NeuroMuscular Transmission (NMT) measurement

The NMT feature provides peripheral nerve stimulation and response measurement that supports electromyography EMG. You can also use the Cardiicap/5 NMT feature as a nerve locator for regional nerve blocking with a regional block cable, however, in this case there is no response measurement.

Nerve stimulation

There are three NMT stimulus modes: Train of Four (TOF), Double Burst 3,3 (DBS) and Single Twitch (ST).

- Train of Four stimulus generates four stimulation pulses at 0.5 second intervals. The response is measured after each stimulus and the ratio of the fourth and first response of the TOF sequence is calculated (TOF%). If the first response does not exceed a certain signal level, TOF% is not calculated due to poor accuracy.
- Double burst (3,3) stimulation includes two bursts with a 750 ms interval. Both bursts consist of three pulses separated by 20 ms intervals. The responses of both bursts are measured, and the ratio of the second and first response is calculated (DBS%). EMG responses are measured immediately after the first stimulus pulse of both bursts.
- Single Twitch stimulation generates one stimulation pulse. The response is measured after the stimulus. To prevent decurarization of the stimulated area, the measurement is automatically stopped after 5 minutes stimulation in 1-second cycle time.

Tetanic/Post-Tetanic Count (PTC)

Tetanic/PTC can measure deeper relaxation than TOF. The tetanic stimulation is produced when **Start** is chosen under **Tetanic/PTC**. The length of stimulation is 5 seconds. The stimulation generates pulses with a frequency of 50 Hz and with a selected pulse width and current. After tetanic stimulation and a three second delay, Single Twitch stimulation is produced to detect the post tetanic count (PTC). PTC describes the number of responses detected after tetanic stimulation. If there is no response, the measurement will be stopped. If responses do not fade away, a maximum of 20 responses will be calculated. If more can be detected, the PTC value is displayed only as "> 20" and measurement stops.

If the TOF, DBS, or ST measurement cycle was on when tetanic stimulation started, the cycle will continue after the PTC. After completing the PTC measurement during 1 minute TOF, DBS, or another PTC measurement is not possible. This is to avoid erroneous readings due to post-tetanic potentiation.

Response

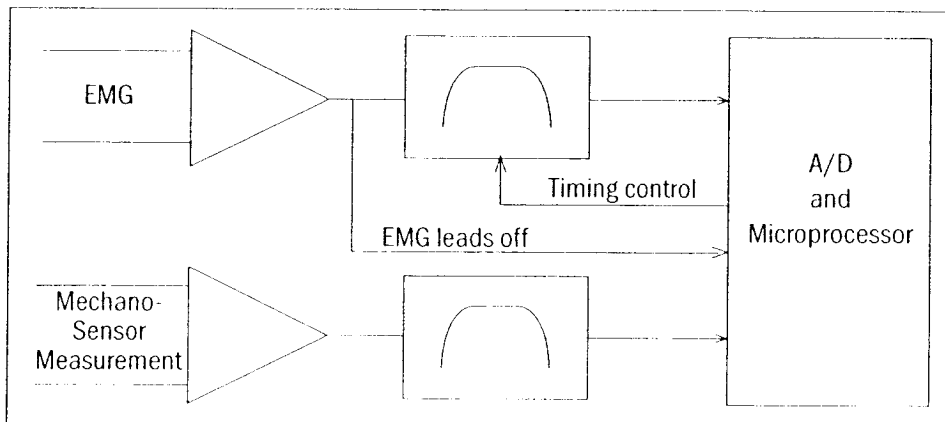

Figure 6-10. Principle of response measurement

Before each stimulation, the sequence offset, noise, and threshold for response detection is measured. Offset is a baseline of the noise measurement. Noise is calculated by the same algorithm as the response signal itself. The response detection threshold is calculated based on the noise. If the response is not greater than the threshold, it is interpreted as no response.

The EMG response is measured as integrated muscle activity. The EMG measurement starts 3 ms after the stimulation and lasts 15 ms. The 3-ms delay helps prevent the effect of stimulation artifact.

When using a MechanoSensor, response is measured as movement of the thumb, which is the area of positive signal.

Regional block

A regional block cable can be used as a nerve locator in local anesthesia. A maximum current of 5.0 mA is given every second, every other second, or every third second. The response measurement is ocular.

6.4 Components for NESTPR hemodynamic parameters

6.4.1 Serial communication

NESTPR

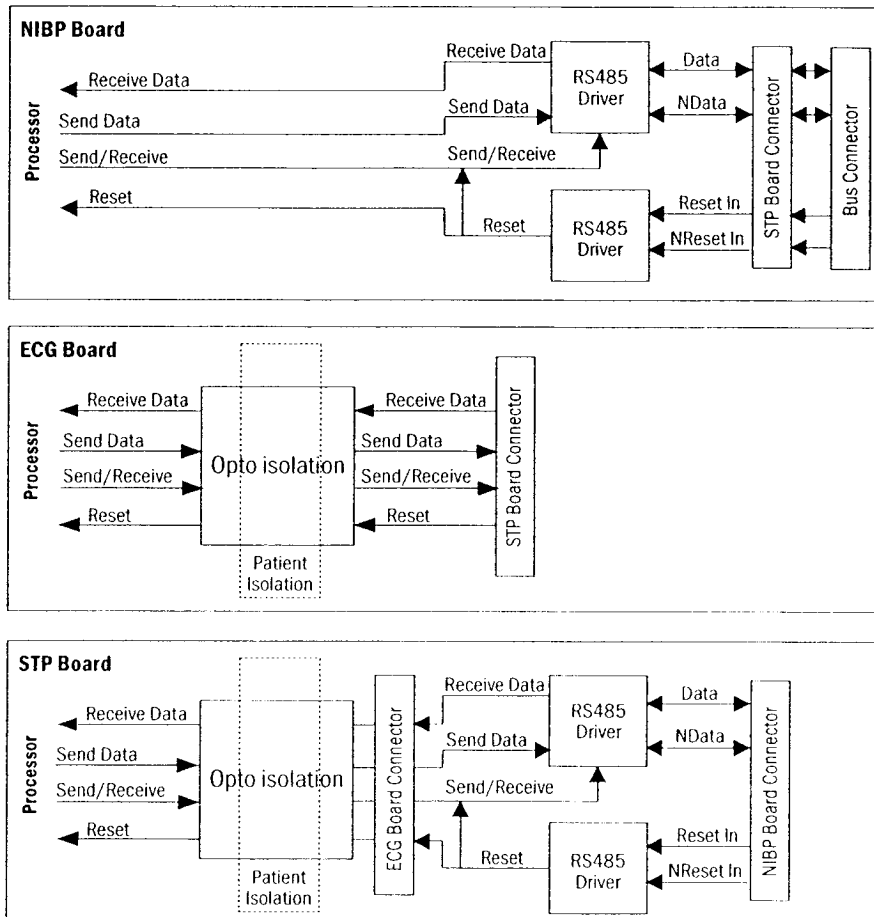

Figure 6-11. Serial communication and opto isolation

Serial communication between the NESTPR unit and the CPU is done by a RS485-type bus whose buffers get their supply voltage (+5 VDC) from the DC/DC board. In the isolation section, their supply voltage (+5 V) is obtained from the isolated power supply. The data transmission rate is 500 kbps.

The serial communication buffers are also controlled by the Reset signal so that when the Reset is active, the buffer does not transfer data. Reset is also an RS485. Additionally, an auxiliary logic power reset keeps the reset active for about 500 ms despite the state of reset in the module bus. Time constant determines the power-up reset time. Components prevent the unit from sending data during reset.

ECG board communication with the module bus is made through RXD and TXD pins.

6.4.2 NIBP board

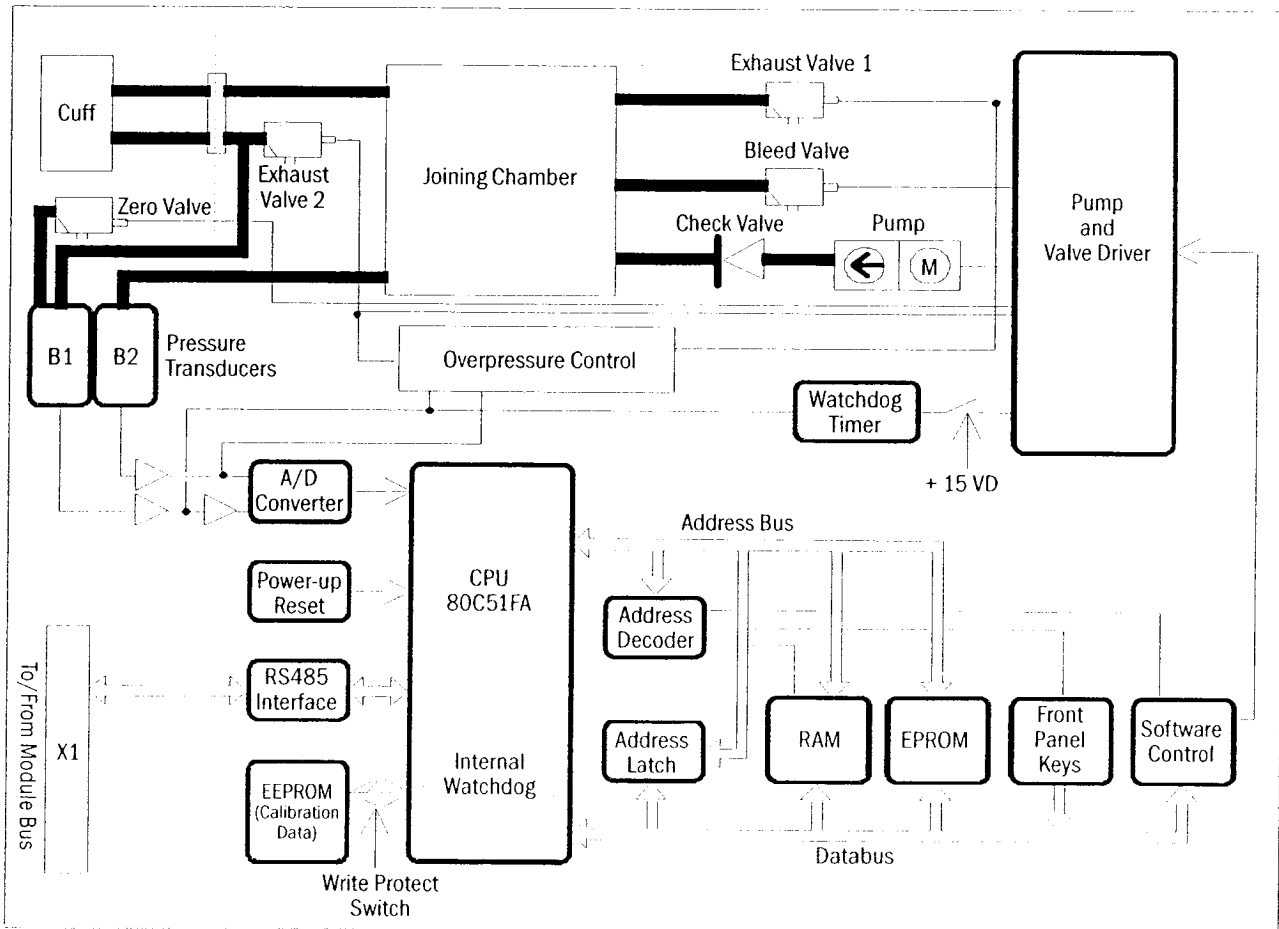

Figure 6-12. NIBP board functional block diagram

Pressure transducers

The NIBP board contains two piezo-resistive pressure transducers (B1 and B2). Transducer B1 measures the pressure of the blood pressure cuff and the pressure fluctuations caused by arterial wall movement. Transducer B2 detects the cuff hose type as well as "Cuff loose" and "Cuff occlusion" conditions. The transducers are temperature-compensated internally. They are supplied by a constant voltage and their output voltage changes up to 40 mV maximum (50 kPa, 375 mmHg).

Signal processing

The NIBP board is controlled with 80C51FA microprocessor at 16 MHz oscillator frequency. The microprocessor system is equipped with its own power-up reset in addition to the external RS485 reset line.

Two signals from the pressure transducers are amplified and sent to the A/D converter. After the converter, digitized signals are sent to the microprocessor for data processing. Before the converter, one signal adjusts the offset to the pressure safety level.

Software control

Software controls the valves and pump. In addition to ON/OFF signals for each component, a common power switch for the valves and the pump is used at pump/valve failures.

Memory

NIBP program memory (EPROM) size is $128k \times 8$. The RAM ($32k \times 8$ bit) stores variable NIBP measurement values. The EEPROM (64×16 bit) stores the calibration values for the pressure transducers, the pulse valve constants gained during measurements, the PC board identification, and the module serial number.

Watchdog timer

The NIBP board is equipped with a software-independent safety circuit to disconnect supply voltages from the pump and the valves if the cuff has been pressurized longer than preset time. The pressure limit is specified to 5 mmHg. As soon as the cuff pressure rises over 5 mmHg, a timer starts counting. The timer is adjusted to stop the pump and open the valves in 2 minutes 10 seconds in adult/child mode and in 1 minute 5 seconds in infant mode.

Valves

Exhaust valves 1 and 2 empty the cuff and the joining chamber after the measurement. Exhaust valve 1 is used as a safety valve in infant mode; it opens at 165 mmHg. Exhaust valve 2 is used as a safety valve in adult mode; it opens at 320 mmHg.

The bleed valve empties the cuff during measurement.

The zero valve connects pressure transducer B1 to open air.

Power supply section

All connections are established via a 25-pin connector (D-type, female). The unit needs a +5 V, ± 15 V, and +15 VD (dirty) power supply to operate. The pump and the valves use a separate +15 VD power line. Supply voltages are generated in the DC/DC board. The reference voltages $\pm 5 V_{ref}$ and $+10 V_{ref}$ are generated on the NIBP board.

6.4.3 ECG board

Patient signals are connected to overload protection circuits (resistors and gas-filled surge arresters) and analog switches to instrumentation amplifiers. The signals are amplified by 480 and limited by slew rate. Then they are A/D-converted, analyzed, and transferred to the module bus in digital form.

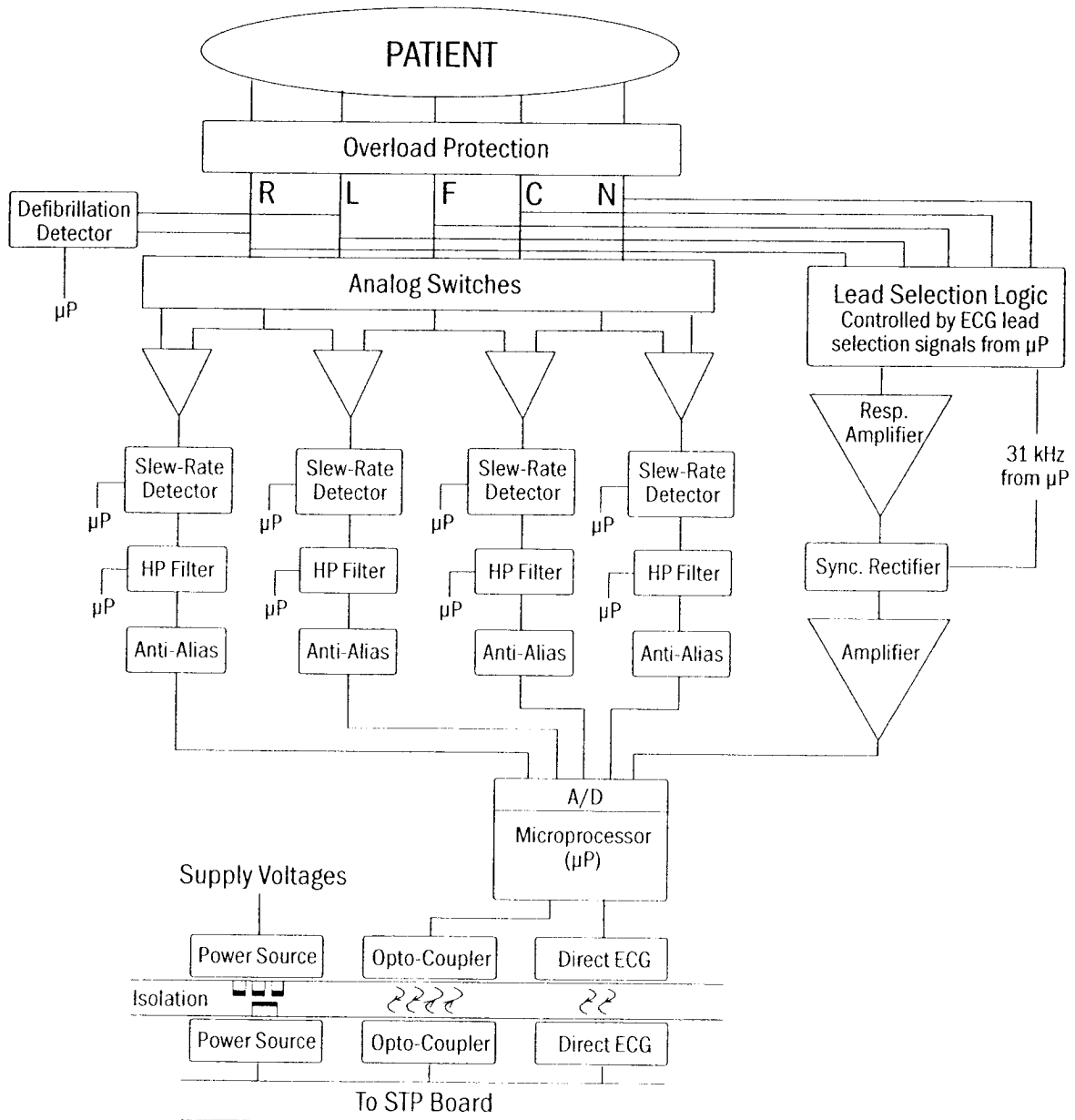

Figure 6-13. ECG board block diagram

Analog ECG section

The ECG cable is connected to connector pins E1 to E6 on the input board, which contains an overload protection circuit.

Analog switches connect leads to amplifiers. The state of the switches depends on the cable type.

Lead-off, noise, and pacemaker are detected by a slew rate detector.

Lower frequency is determined by a high-pass (HP) filter 0.5 Hz (monitor bandwidth) or 0.05 Hz (diagnostic or ST bandwidth).

ECG filtering

The Cardiicap/5 monitor has three ECG filtering modes:

MONITORING	0.5 to 30 Hz (with 50 Hz reject filter) 0.5 to 40 Hz (with 60 Hz reject filter)
DIAGNOSTIC	0.05 to 100 Hz
ST FILTER	0.05 to 30 Hz (with 50 Hz reject filter) 0.05 to 40 Hz (with 60 Hz reject filter)

Filtering reduces high-frequency noise and low-frequency (for example, respiratory) movement artifacts.

The monitoring filter is used in normal monitoring. The diagnostic filter is used if more accurate diagnostic information is needed. The ST filter gives more accurate information of ST segment, but reduces high-frequency noise.

The high-pass filters 0.5 Hz and 0.05 Hz are done with hardware. The monitor sends a command to the NESTPR unit determining which corner frequency (0.5 Hz or 0.05 Hz) is to be used.

The 50 Hz and 60 Hz reject filters are low-pass filters with zero at 50 Hz or 60 Hz correspondingly and they are done with software. They are for the mains supply filtering. When these filters are used, 3 dB value for low-pass filter is 30 Hz or 40 Hz.

Software filters are not used in diagnostic mode. Then, the upper frequency is limited by hardware and the -3 dB frequency is 100 Hz.

Respiration section

Analog switches control the current supply source of the impedance respiration measurement. The lead selection for the 3-lead cable can be seen from the following table:

Selected lead	Current source between	Signal measured from
I	R - L	F
II	R - F	L
III	L - F	R

Position on body surface	IEC Standard coding	AAMI standard coding
right arm	R = red	RA = white
left arm	L = yellow	LA = black
left leg	F = green	LL = red

When the 5-lead cable is used, the current source is between L-F and the signal is measured from the N, independently on the lead selection.

The respiration amplifier consists of the operational amplifiers and the components around them. An analog switch controls the gain of the first stage of the preamplifier.

The synchronous rectifier consists of the analog switches, which detect the respiration signal from 31 kHz amplitude modulated raw signal.

The amplifier stage consists of the differential amplifier and the last amplifier. The differential amplifier consists of the operational amplifiers and the components around them. This stage is AC-coupled on both sides for minimizing the offset voltages.

The last amplifier amplifies the signal derived from the differential amplifier stage.

The respiration signal is zeroed at the beginning of the measurement. Zeroing is also used for fast recovery of the measurement after the motion artifact. This is done in the amplifier section.

NOTE: The respiration measurement is switched OFF for 20 seconds when defibrillation is detected at the defibrillation detector.

Microprocessor section

The microprocessor contains RAM and EPROM. The processor uses external EEPROM memory. The microprocessor's internal 8-channel A/D converter converts the ECG signals to digital form.

Isolated section

See *STP board* later in this chapter.

The patient isolation of ECG is 5 kV.

WARNING: Do not touch battery-operated monitor during defibrillation procedure.

Power supply section

See *STP board* later in this chapter.

There is a test connector (X20) on the board for voltages +5 VREF, +5V, +12V, GND and -12V.

6.4.4 STP board

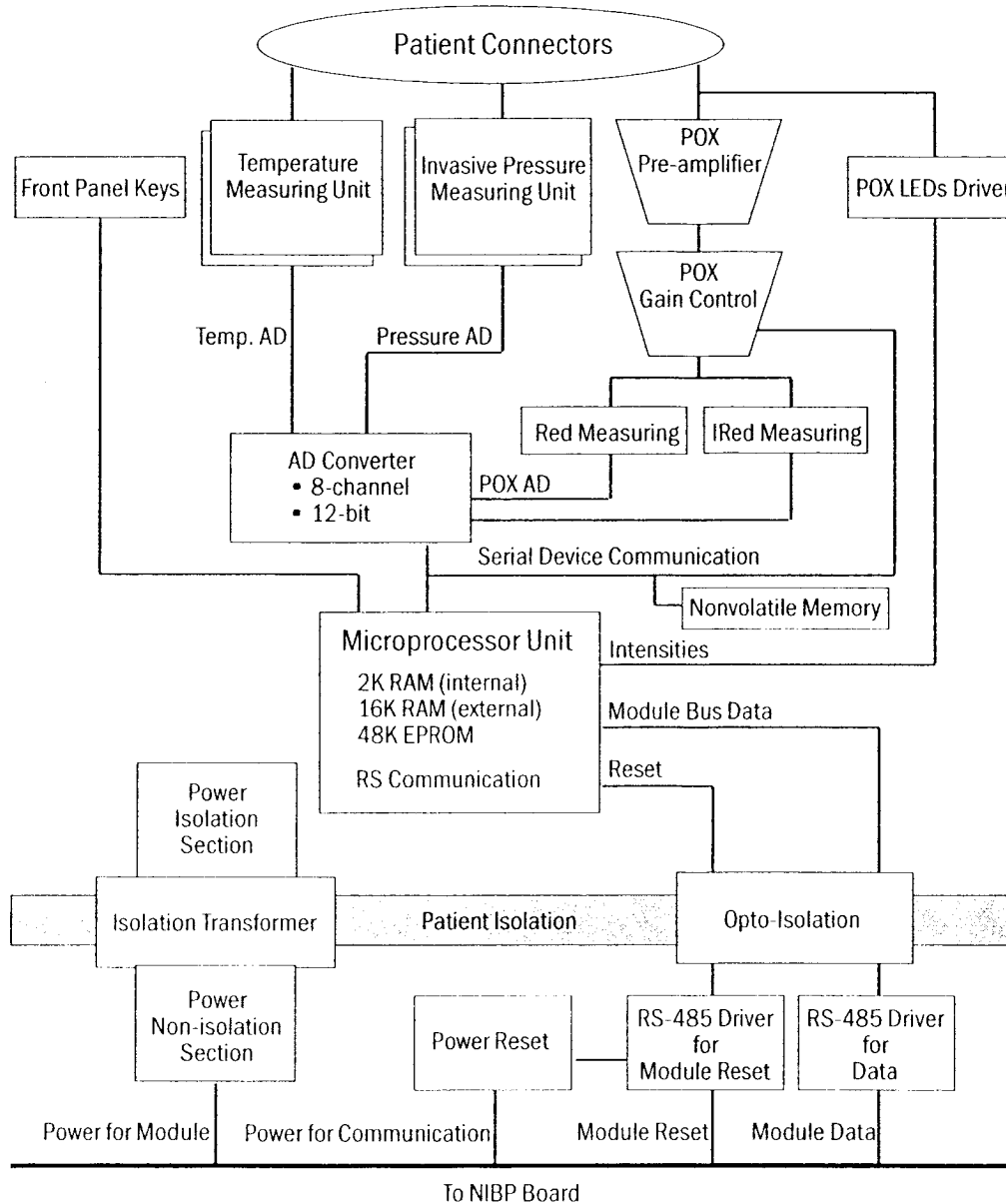

Figure 6-14. STP board block diagram

Microprocessor unit

The STP board uses an Intel 80C196KC-16 processor with three A/D converters, external memories, an 8-bit data bus, a 16 MHz oscillator, an open collector reset, and a watchdog timer. The processor's internal UART communicates with the CPU board. High speed I/O obtains the pulse control sequence for pulse oximetry measurement. The oscillator provides its timing clock.

Isolation section

The outputs of the two opto isolators are analog signals in the isolated section, however, the signal is processed on logical high-low level. Reset line is an open collector type with a pull-up resistor, allowing the processor to use its internal watchdog function.

Power supply section

Isolated supply voltages of the boards are developed from +15 V dirty voltage from the DC/DC board. The power supply is a switched mode circuit, where the FET transistor switch is controlled by an oscillator using a bipolar timer. The frequency of the oscillator is about 30 kHz and the pulse ratio is 50%. Control of the FET switch is slowed to suppress spurious interference.

A special pulse transformer is used in the circuit. In the secondary circuit, normal linear regulators are used except for +5 V (low drop type linear regulator).

6.4.5 STP board—Pulse oximetry measurement section

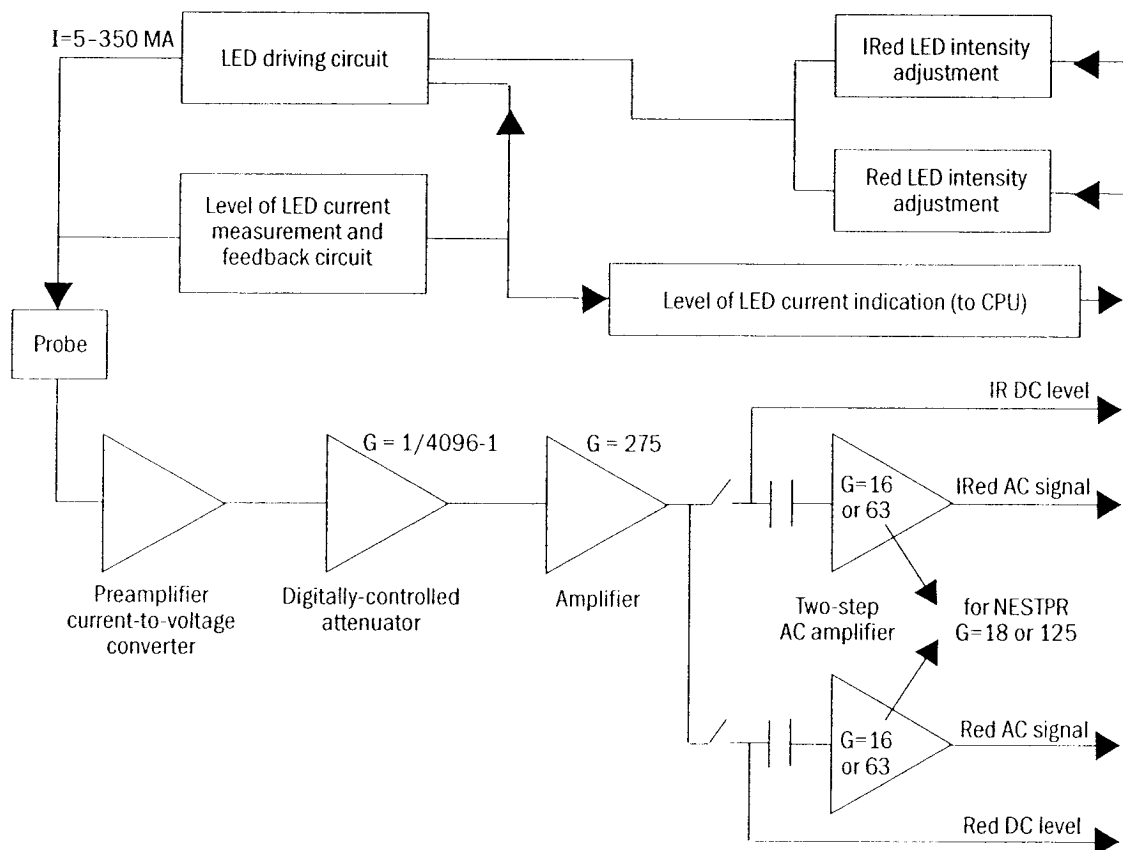

Figure 6-15. Pulse oximetry measurement block diagram

LED control signals

The processor sends pulse-width modulated signals, IRED intensity and RED intensity, that are converted to DC voltage and filtered. Switches send either RED or IRED intensity forward to the amplifier in the LED driving circuit.

LED driving circuit

The differential amplifier circuit measures the voltage difference that corresponds to the LED current. Its output is sent back to the processor in 0 to 5 V level. There are feedback circuits from LED current measurement and LED intensity control.

Background light is measured by picking up a sample from the signal. The sample is modified to 0 to 5 V level and sent to the processor.

Measured signal preamplification

The preamplifier is a current-to-voltage converter with gain selection. The higher gain is used for measuring thin tissue.

Digitally controlled amplifier

The D/A converter is a digitally-controlled amplifier after which there is another constant amplifier.

Red and infrared channel separation

Switches separate red and infrared channels. The operational amplifier functions as a buffer and after this, an infrared DC signal is sent to the processor. A capacitor separates out the AC signal, which is sent to the processor after amplification. There is a switch to choose the amplification constant.

6.4.6 STP board—Temperature measurement section

The value of NTC resistor in the probe depends on the patient's temperature, which is measured with the following principle.

The temperature signal is produced by voltage dividers, part of which is the temperature probe used on the patient. The output is amplified by the calibrated amplifier whose offset voltage makes its output spread on both sides of zero. A wider output range (measurement range) means better resolution.

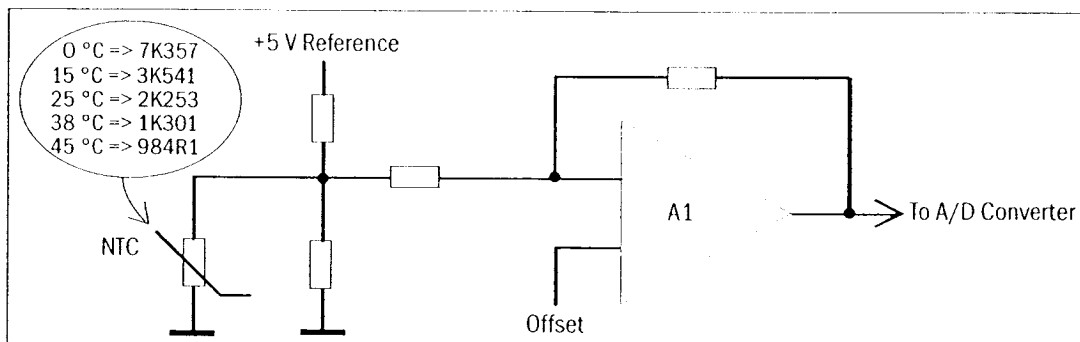

Figure 6-16. Temperature measurement principle

6.4.7 STP board—Invasive blood pressure measurement section

Isolated +5 V voltage is supplied to the pressure transducer. From the bridge connection a differential voltage, which depends on pressure and supplied voltage, is calculated (see the formula below).

$$U_{out} = U_{in} \times \text{Pressure} \times 5 \text{ V}$$

where $U_{in} = 5 \text{ V}$

$$U_{out} = 25 \text{ V} \times \text{Pressure [mmHg]}$$

Pressure amplification is realized in the instrumentation amplifier. Gain of the amplifier is set so that the level of the signal transferred to the A/D converter stays within the measurement range even when there are circumstantial offsets or offsets caused by the transducer. A filter before the amplifier attenuates high frequency disturbances.

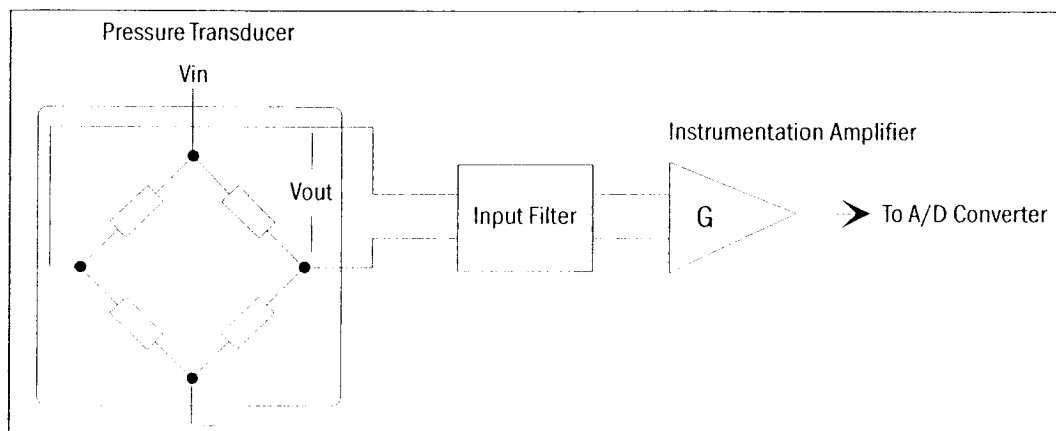

Figure 6-17. Pressure measurement principle

6.5 N-XOSAT or N-XNSAT optional pulse oximetry components

6.5.1 Datex-Ohmeda enhanced pulse oximetry components (N-XOSAT option)

The Datex-Ohmeda enhanced pulse oximetry option (N-XOSAT) consists of the following parts:

- Sensor connector board and cable assembly
- Datex-Ohmeda pulse oximetry board (OSAT board)
- SpO₂ interface board

The measured SpO₂, pulse rate values and status information are transmitted through the connector board/cable assembly to the pulse oximetry board, then transferred to the SpO₂ interface board. Communication between the pulse oximetry board and the SpO₂ interface board is established through an RS-232C serial interface. The SpO₂ interface board transmits the measurement information to the module bus of the monitor through an RS485 serial interface.

Serial communications connector

The OSAT board includes a bi-directional (2-wire) serial communications port. The serial interface connector is a 14-pin, dual row header. The pin assignments are shown below.

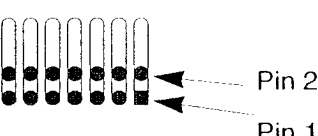
Pin	Description	Pin	Description	Pin Numbering
1	+5IN	2	COMMON	 <p>Connector viewed from solder side of board.</p>
3	COMMON	4	NO CONNECT	
5	COMMON	6	NO CONNECT	
7	UNUSED	8	TX- TRANSMIT	
9	RX- RECEIVE	10	CTS	
11	RESET (Active Low)	12	COMMON	
13	NO CONNECT	14	COMMON	

Sensor interface connector

The sensor interface connector is a 10 pin, dual row header. The pin assignments are shown below.

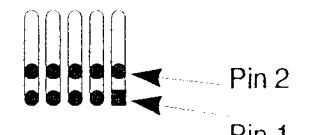
Pin	Description	Pin	Description	Pin Numbering
1	DETECTOR ANODE	2	DETECTOR RETURN	 <p>Connector viewed from solder side of board.</p>
3	ID RESISTOR COMMON	4	LED ANODES	
5	NO CONNECT	6	ID RESISTOR # 1	
7	NO CONNECT	8	RED CATHODE	
9	IR CATHODE	10	NO CONNECT	

6.5.2 Nellcor pulse oximetry components (N-XNSAT option)

The Nellcor compatible pulse oximetry option (N-XNSAT) consists of the following parts:

- Sensor connector board and cable assembly
- Nellcor pulse oximetry board (NSAT board)
- SpO₂ interface board

Sensors can be plugged into the monitor directly or used with sensor extension cables available from Nellcor. Sensors plug into a 9-pin female connector (D-type) on the front of the monitor. This connector is mounted on a small PC board, the connector board. This two-board system consumes approximately 1.3 W of power.

- The Nellcor pulse oximetry board is a surface-mounted PC board manufactured by Nellcor. It contains the signal processing electronics and software that are based on Nellcor stand-alone pulse oximeters. It is used with an internal preamplifier.
- The connector board/cable assembly consists of the patient connector, the connector board, and the cable that connects to the pulse oximetry board. The connector board contains the sensor interface connector, a differential preamplifier, and EMI protection. It provides analog signals to the pulse oximetry board from the oximeter sensor through a preamplifier interface cable.

The measured SpO₂, pulse rate values, and status information are transferred from the pulse oximetry board to the SpO₂ interface board. Communication between the pulse oximetry board and the SpO₂ interface board is established through an RS-232C serial interface. The SpO₂ interface board transmits the measurement information to the module bus of the monitor through an RS485 serial interface.

Communication protocol jumper

Jumpers on the Nellcor pulse oximetry board determine the interface used for communication. A jumper should always be installed on J6 (interface selection).

NOTE: New, replacement boards may have jumpers installed on J5 (baud rate selection) and J6. The jumper on J5 should be removed before installing the board.

6.5.3 SpO₂ interface board (for N-XOSAT or N-XNSAT option)

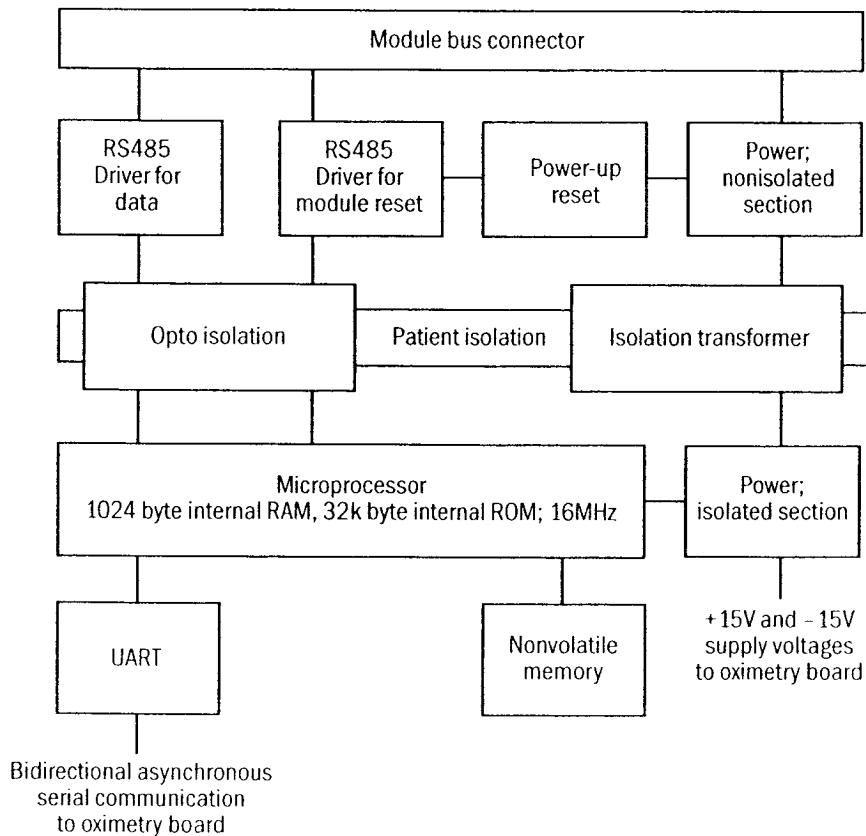

Figure 6-18. SpO₂ interface board block diagram

NOTE: Two switches located on the board are not used and have no function with the Cardiicap/5.

RS485 drivers

The SpO₂ interface board contains drivers for data and for module reset functions. They drive the RS485-type serial communication bus between the pulse oximetry unit and the Central Unit. Data transmission speed of the bus is 500 kbps.

In addition to RS485 bus RESET, a Power-up reset keeps the RESET pin of the CPU active during power up for about 500 ms despite the state at the RS485 bus RESET. This is used to prevent the sending of RS485 data during the RESET of the module.

Power supply, non-isolated section

The power supply is a half bridge type, switched mode circuit, where the driver FETs are controlled by a quartz oscillator. The load of the half bridge is the primary of the isolation transformer. The voltage, +15 Vdirty from the Central Unit, is used as the supply voltage of the switched mode circuit.

Power supply, isolated section

The secondary voltages of the isolation transformer are rectified, filtered, and regulated. The voltages can be measured from the test connector (X11).

Opto isolation

The serial communication bus signals between the pulse oximetry board and the Central Unit are transferred through the patient isolation section by high speed opto couplers.

Microprocessor, UART, nonvolatile memory

The microprocessor, with on-chip memory, converts and transfers data from the pulse oximetry board to the monitor.

The UART provides bidirectional asynchronous serial communication between the pulse oximetry board and interface board CPU.

Nonvolatile memory stores identification information, such as serial number, control number, date, etc.

Module bus connector

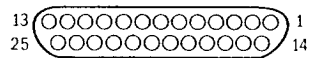

Pin No	I/O	Signal
1	I	RESET_RS485*
2	I	-15 VDC
3	I	+15 VDIRTY*
4	I	+15 VDC
5	I/O	-DATA_RS485*
6	I/O	DATA_RS485*
7	-	Ground & Shield*
8	I	-RESET_RS485*
9	I	CTSB
10	O	RTSB
11	I	RXDB
12	O	TXDB
13	-	Ground & Shield*

Pin No	I/O	Signal
14	I	+32 VDIRTY
15	I	GroundDIRTY*
16	I	CTSC
17	O	RTSC
18	I	RXDC
19	O	TXDC
20	-	ON/STANDBY
21	-	BITOIN
22	-	RXDD_RS232
23	-	TXDD_RS232
24	I	+5 VDC
25	I	+5 VDC

*Used in the OSAT or NSAT pulse oximetry unit

Test connector

Pin No	Voltage	Name	Note
1	+5V	+5VTEST	Supply voltage to the SpO ₂ interface board
2	+5V	+5Vn	Supply voltage to the pulse oximetry board
3	+15V	+15Vn	Supply voltage to the pulse oximetry board
4	-	GND	FGND
5	-	-15V	-15Vn
6	-	-	N/C

6.6 Airway gases and spirometry components

Airway gas measurement involves the following components:

- Gas sampling system
- TPX measuring unit
- OM measuring unit and OM board
- PVX measuring unit and PVX board for Patient Spirometry (N-XV option)
- CPU board

6.6.1 Gas sampling system

The gas sampling system draws a gas sample to the analyzers at a fixed rate. It also removes water and impurities from the gas sample. A sample line is connected to the water trap. The pump draws gas through the sampling line to the gas measuring units. After the measurements, the gas is exhausted from the sample gas out connector.

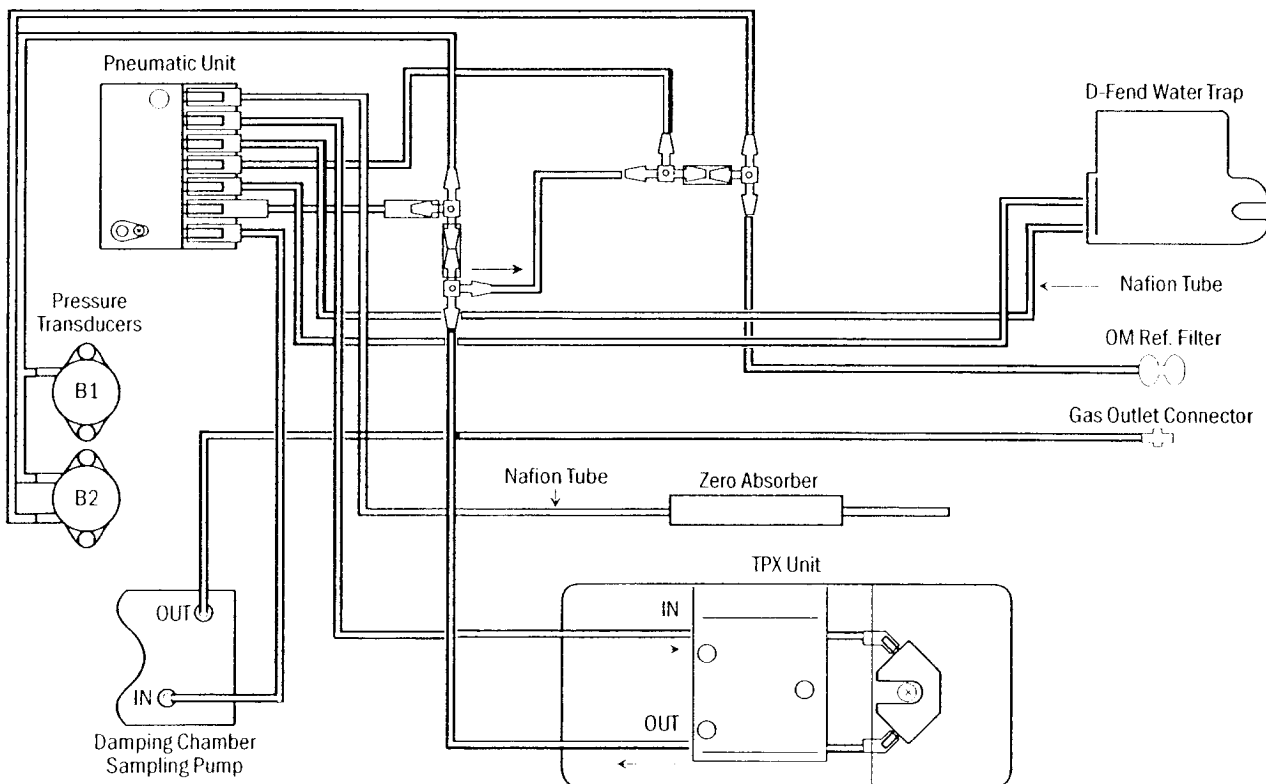

Figure 6-19. Gas sampling system (N-XC option)

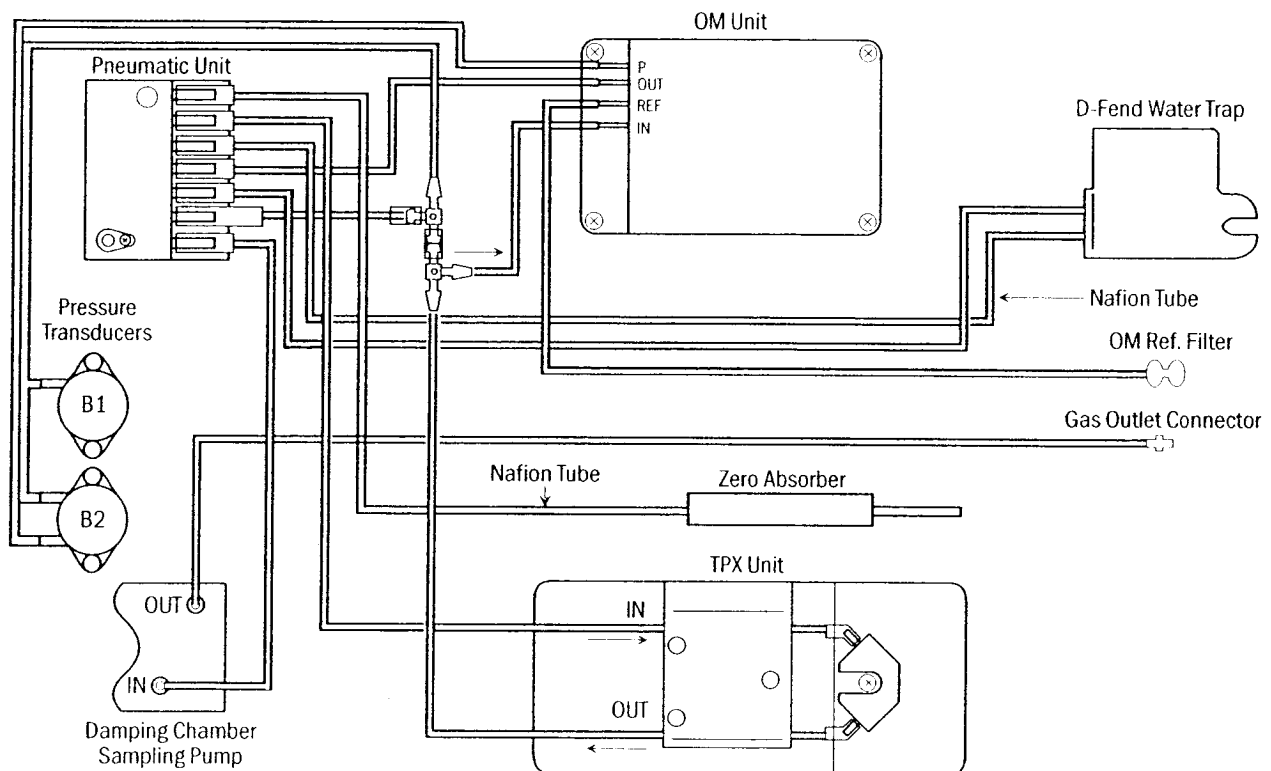

Figure 6-20. Gas sampling system (N-XCO and N-XCAiO options)

D-fend™

The sample is drawn through a sampling line to the water trap, where it is separated into a main flow and a side flow. The main flow is drawn through into the analyzers. A hydrophobic filter separates this flow from the patient side. The side flow creates a slight subatmospheric pressure within the D-fend water trap, causing fluid removed by the hydrophobic filter to collect in the bottle.

Zero valve

The main flow passes through a magnetic valve before proceeding to the analyzers. This valve is activated to establish the zero points for the TPX and OM units. When the valve is activated, room air is drawn into the internal system and the gas sensors.

Nafion™ tube ¹⁾

A Nafion tube between the water trap and the zero valve balances the sample gas humidity with that of ambient air. The tube prevents errors caused by the effect of water vapor on gas partial pressure when humid gases are measured after calibration with dry gases.

Gas analyzers

After passing through the zero valve and Nafion tube, the gas passes through the TPX and the OM units. The oxygen sensor has two inputs. One input accepts the main flow and the other draws in room air for reference. Both gas flows exit from a single port.

¹⁾ Nafion is a trademark of Perma Pure Inc.

Sample flow differential pressure transducer

The sample flow differential pressure transducer measures pressure drop across the OM inlet restrictor and calculates sample flow from the pressure difference.

Working pressure transducer

The working pressure transducer measures absolute working pressure between the TPX unit and the OM unit. It is used for the "Occlusion," "Check D-fend," "Replace D-fend," and "Check sample gas outlet" messages.

Pneumatic unit

The pneumatic unit contains a zeroing valve, an occlusion valve, and tubing connections. A series of restrictors and chambers form a pneumatic filter to prevent pressure oscillations from the pump to reach the measuring units. Zeroing and occlusion valve connections to room air include a dust filter.

Occlusion valve

The valve is activated when the sampling line becomes occluded. The main flow is diverted to the side flow of the D-fend water trap to remove the occlusion quickly.

Sampling pump and damping chamber

The gas sampling pump is a membrane pump that is run by a brushless DC motor. Sample flow is measured with a differential pressure transducer across a known restriction. The motor is automatically controlled to maintain a constant flow, even when the D-fend water trap ages and starts to get occluded. It also enables use of sample tubes with varying lengths and diameters.

The damping chamber is used to even out the pulsating flow and silence the exhaust flow.

NOTE: The flow is never reversed towards the patient.

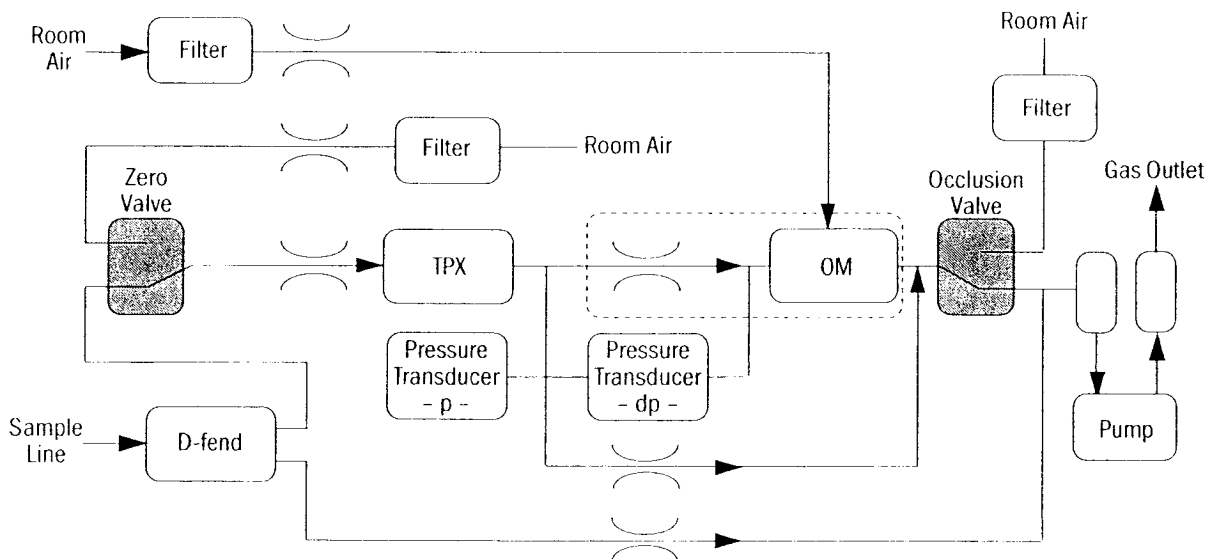

Figure 6-21. Gas tubing layout

6.6.2 TPX measuring unit

The TPX unit is a non-dispersive infrared analyzer, measuring absorption of the gas sample at seven infrared wavelengths, which are selected using optical narrow band filters. The IR lamp is a 4W filament, surrounded by thermal isolation. A hole in the isolation passes the radiation to a conical, 4 mm long measuring chamber.

From the sample chamber, radiation goes into seven tubular light guides that have reflective inner surfaces. A thermopile detector with an optical filter in front of it is at the other end of each light guide.

The temperature sensor measures the temperature of the TPX unit and is used for temperature compensation.

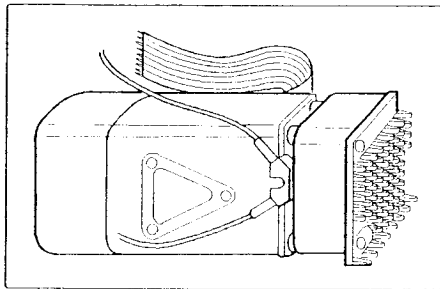

Figure 6-22. TPX measuring unit

6.6.3 OM measuring unit and board

Oxygen measurement is based on paramagnetic susceptibility. The gas and the reference gas (usually room air) are conducted into a gap in an electromagnet. A strong magnetic field is switched on and off at a frequency of approximately 165 Hz. An alternating differential pressure is generated between the sample and reference inputs due to forces acting on the oxygen molecules in a magnetic field gradient.

The pressure is measured with a sensitive differential transducer, rectified with a synchronous detector, and amplified to produce a DC voltage proportional to the oxygen partial pressure difference of the two gases.

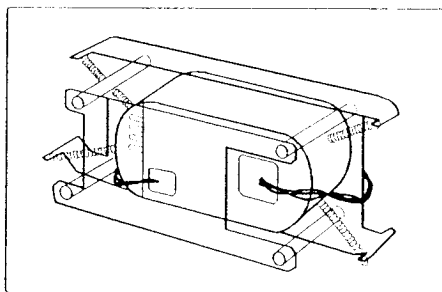

Figure 6-23. OM measuring unit

OM board

The Oxygen board contains the specific electronics for the oxygen sensor. Sample flow measurement and sampling system pressure sensors are on this board. It also contains EEPROMs that store calibration data of both the TPX and OM sensors.

6.6.4 PVX measuring unit and board (Patient Spirometry, N-XV option)

NOTE: Never apply overpressure or negative pressure of more than 300 cmH₂O to the flow and volume tubing. Differential pressure maximum is 25 cmH₂O on one port at a time (when connecting tubes, for example).

Patient Spirometry provides patient respiration monitoring capabilities using D-lite and Pedi-lite flow sensors. When Patient Spirometry is used, a special sensor (D-lite) replaces the normal airway adapter in the patient circuit. Double lumen tubing is attached to the two connectors on the adapter and on the monitor front panel.

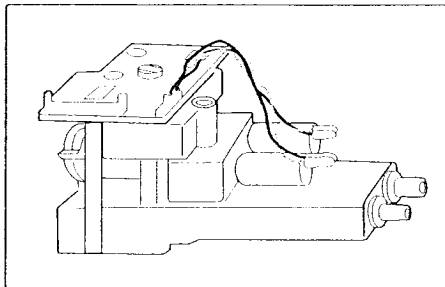

Figure 6-24. PVX measuring unit

The measurement unit consists of airway connections, two pressure transducers, valves, and preamplifiers. The preamplifiers connect to the A/D converter on the main monitor CPU.

Measurement is based on measuring the kinetic gas pressure and is performed using the Pitot effect. A pressure transducer measures the Pitot pressure. The signal is linearized and corrected according to the density of the gas. Flow speed is calculated from the pressure and TV is integrated from it.

The breathing flow of a patient passing through the D-lite adapter creates a pressure difference. This pressure difference is measured by pressure transducer B1. Overpressure and negative pressure in airways are measured by pressure transducer B2.

PVX board

The Spirometry board connects to the Oxygen board. It contains pressure sensors for airway pressure and flow measurement differential pressure, and the preamplifiers for them. An EEPROM stores spirometry calibration data.

6.6.5 Gas unit CPU board

The gas unit CPU board contains the processor, memory, and A/D converters that are common to the whole unit. The board also contains TPX sensor preamplifiers and drivers for the valves, fan, pump, and lamp. The unit connects to the module bus through an RS485 serial channel.

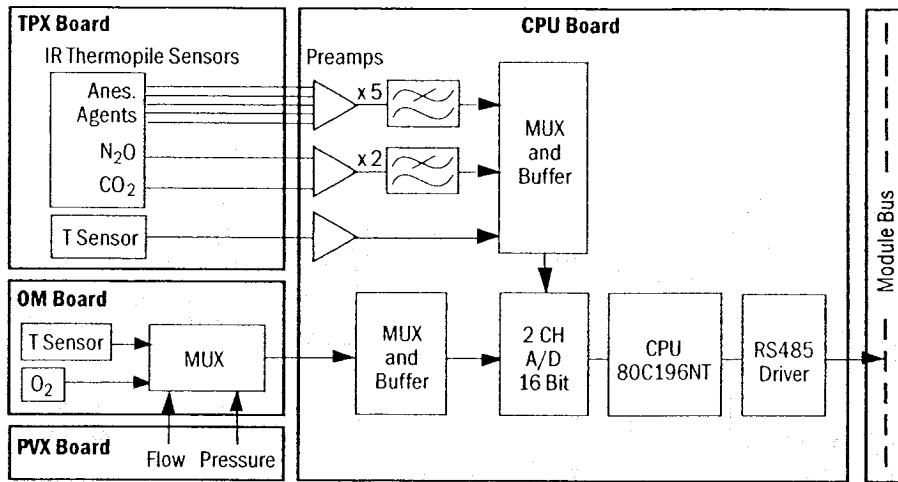

Figure 6-25. Signal processing

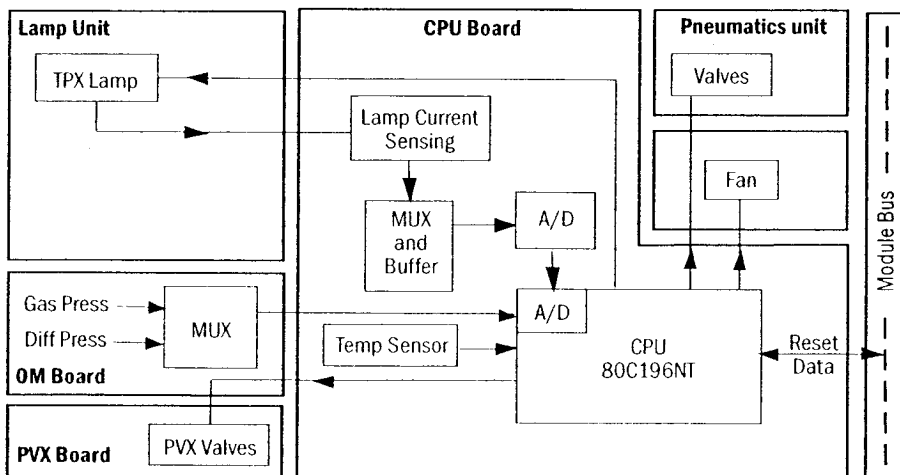

Figure 6-26. Control logic

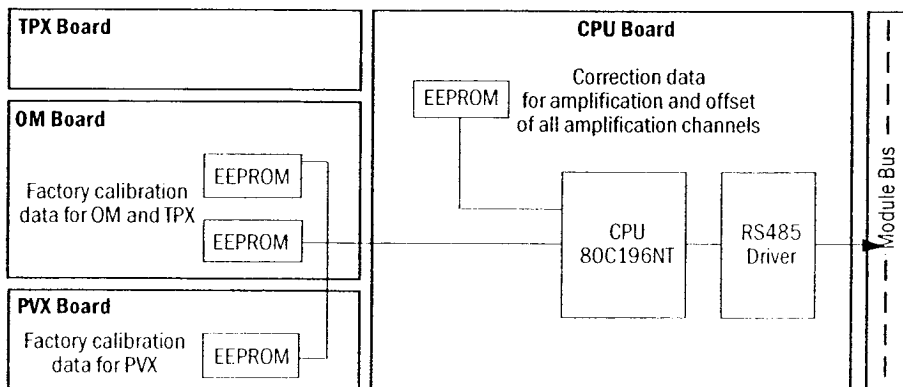

Figure 6-27. Calibration data stored in EEPROM

6.7 NMT components

6.7.1 NMT board

The NMT circuit board consists of the following functional sections:

- Constant current stimulator.
- Measuring electronics for the EMG signals.
- Microprocessor for stimulation and measurement control, and for counting measurement results.
- Serial communication.

The serial bus speed is 500 kbps and the bus itself is half duplex (data can be transferred in both directions but only one way at a time).

Serial communication

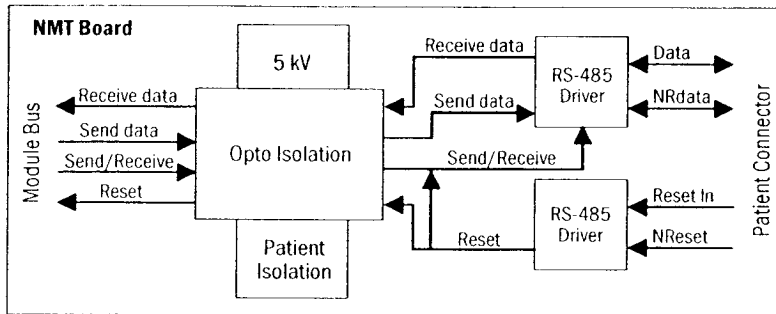

Figure 6-28. NMT serial communication and opto isolation

Stimulator

The constant current stimulator generates pulses whose amplitude is independent of the load. The main components of the stimulator are a transformer, a capacitor and a transistor. The transformer produces a high voltage which charges the capacitor and the transistor adjusts the pulse width and amplitude of the current.

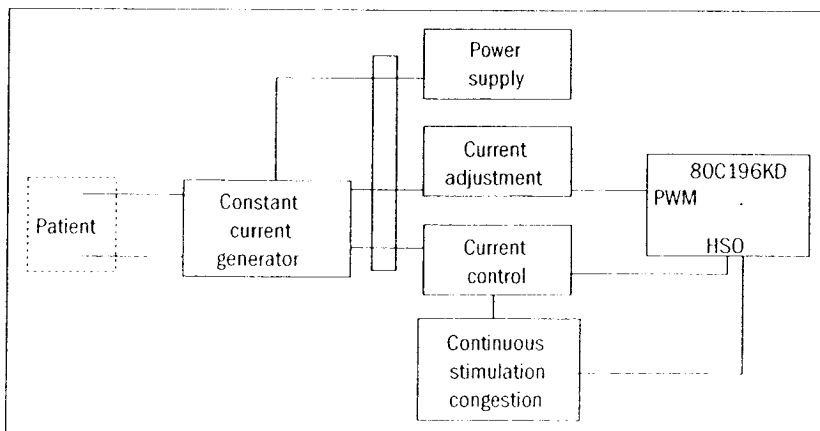

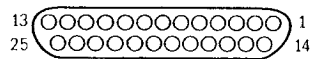

Figure 6-29. NMT stimulator block diagram

6.7.2 Front panel connector (NMT)

NMT connector	Pin No.	Signal
	1	EMG signal +
	2	EMG signal -
	3	Not used
	4	Stimulus +
	5	Stimulus -
	6	Ground
	7	Not connected
	8	Sensor identification
	9	+5 V
	10	Mechanical signal

6.7.3 Module bus connector



Pin No.	I/O	Signal
1	I	RESET_RS485
2	I	-15 VDC
3	I	+15 VDIRTY
4	I	+15 VDC
5	I/O	-DATA_RS485
6	I/O	DATA_RS485
7	-	Ground & Shield
8	I	-RESET_RS485
9	I	CTSB
10	O	RTSB
11	I	RXDB
12	O	TXDB
13	-	Ground & Shield
14	I	+32 VDIRTY
15	I	GroundDIRTY
16	I	CTSC
17	O	RTSC
18	I	RXDC
19	O	TXDC
20	-	ON/STANDBY
21	-	PWM_ECG
22	-	RXDD_RS232
23	-	TXDD_RS232
24	I	+5 VDC
25	I	+5 VDC

Chapter 7. Service Procedures

7.1 General service information	7-1
Tools.....	7-2
7.2 Monitor software installation	7-1
“Cold start” instructions	7-1
“Warm start” instructions.....	7-1
7.3 Replacement procedures	7-2
7.3.1 Disassembling the frame assembly.....	7-2
7.1.2 Mother board removal	7-2
7.1.3 ECG, NIBP, and STP board replacement	7-3
NESTPR unit removal	7-3
ECG board replacement	7-3
NIBP board replacement.....	7-3
STP board replacement	7-3
7.1.4 Backplate unit removal.....	7-3
7.1.5 Gas unit CPU board, pump, and fan replacement.....	7-4
Airway-gas unit removal	7-4
Gas unit CPU board replacement	7-4
Pump unit replacement	7-4
Fan replacement.....	7-4
7.1.6 AC/DC unit replacement.....	7-5
7.1.7 DC/DC board replacement.....	7-5
7.1.8 Recorder unit replacement	7-5
7.1.9 Inverter board and Backlight board replacement.....	7-5
Inverter board replacement	7-5
7.1.10 CPU battery replacement	7-6
7.1.11 CPU board replacement	7-7
7.1.12 LCD display, LCD display backlight, and keyboard replacement.....	7-7
LCD display removal	7-7
Replacing LCD display backlights.....	7-7
Replacing the keyboard.....	7-7
7.1.13 Enhanced pulse oximetry (N-XOSAT) or SpO ₂ interface board replacement	7-8
7.1.14 Nellcor pulse oximetry (N-XNSAT) or SpO ₂ interface board replacement.....	7-9
7.1.15 NMT board or NMT cable assembly replacement	7-9
7.4 Adjustments and calibration	7-10
7.4.1 Pressure safety-level detection "OFFSET"	7-10
7.4.2 NIBP calibration check	7-11
Using a manometer to check NIBP calibration.....	7-11
7.4.3 NIBP calibration	7-12
7.4.4 Temperature calibration	7-13
7.4.5 Invasive pressure calibration.....	7-13

7.4.6	General checks for gas system components.....	7-14
	Oxygen measuring (OM) unit.....	7-14
	TPX measuring unit.....	7-14
	PVX measuring unit.....	7-14
	Gas unit CPU board.....	7-14
7.4.7	Gas sampling system leak test.....	7-15
7.4.8	Flow rate checks and adjustments.....	7-15
	Flow rate checks.....	7-15
	Flow rate adjustment.....	7-15
7.4.9	Spirometry leakage test and calibration.....	7-16
7.4.10	Gas calibration.....	7-17
	Calibration adjustments.....	7-18
	Autozeroing intervals.....	7-18

Table of Figures

Figure 7-1.	CPU battery replacement.....	7-6
Figure 7-2.	SpO ₂ interface board.....	7-8
Figure 7-3.	NIBP board.....	7-10
Figure 7-4.	Calibration switch.....	7-12
Figure 7-5.	Attaching the regulator.....	7-17
Figure 7-6.	Connecting a sampling line and feeding gas.....	7-17

7. SERVICE PROCEDURES

7.1 General service information

Field service of the Cardiocap/5 monitor is limited to replacing faulty circuit boards, mechanical parts, or a real-time clock battery. Some boards may be returned to Datex-Ohmeda for exchange.

For service advice from Datex-Ohmeda, please provide the unit serial number, full type designation, and a detailed fault description.

CAUTION: Only trained personnel with the appropriate tools and equipment shall perform the tests and repairs outlined in this chapter. Unauthorized service may void warranty of the unit.

CAUTION: Electrostatic discharge through the PC boards may damage the components. Before replacing PC boards, wear a static-control wrist strap. Handle all PC boards by their non-conductive edges and use anti-static containers when transporting them.

CAUTION: When reassembling the monitor, make sure all cables and tubing are reconnected properly and are not pinched between other components.

7.2 Monitor software installation

“Cold start” instructions

Follow these installation instructions if the monitor has been off for more than 15 minutes:

1. Insert the service software PC card into the data card slot closest to the display.
2. Power on the monitor. Both LEDs illuminate and the screen remains blank for approximately two minutes while loading.
3. When the normal monitoring screen is displayed, remove the card.

“Warm start” instructions

Follow these instructions if the monitor has been off for less than 15 minutes:

1. Insert the service software PC card into the data card slot closest to the display.
2. To perform a factory reset, push the ComWheel and select:
Install/Service (16-4-34)
Service (26-23-8)
Monitor
Factory Reset

Both LEDs illuminate and the screen remains blank for approximately two minutes while loading.

3. When the normal monitoring screen is displayed, remove the PC card.

7.3 Replacement procedures

NOTE: Reassembly is essentially the reverse of disassembly. When reassembling the unit, make sure that the cables and tubes, if any, are not pinched between the boards.

Tools

- Screwdriver (pozidrive)
- Hexagon driver (3.0 mm)
- Pliers
- Cable tie

7.3.1 Disassembling the frame assembly

1. Remove the 4 hexagon and 13 pozidrive screws that hold the back cover.
2. To pull the front-cover unit apart from the inner-parts unit, remove the 4 screws that hold the front-cover unit and the inner-parts unit together.
 - Turn the monitor on its side and disconnect the NIBP and gas sampling line tubes.
NOTE: The foremost NIBP tube is connected to the upper NIBP connector. Notice the correct order of the main stream and sidestream tubes. The Nafion™ tube connects to the outer D-Fend connector.
 - Disconnect all patient connector cables from the front panel.
 - Disconnect 2 cables (blue flat cable and black 4-terminal cable) from the PVX board.
 - Disconnect 3 flat cables and white network cable from the CPU board.
 - Disconnect the power cable from the CPU board by pinching the retainers with a screwdriver.
 - Disconnect the recorder power cable.
3. Lay the front cover unit so that the weight of the unit does not stress the ComWheel. Protect the LCD screen from scratches.

NOTE: When reassembling the frame, be sure the gasket between the front cover and the back-cover frame is placed properly.

CAUTION: When reassembling the monitor, make sure all cables and tubing are connected properly.

7.3.2 Mother board removal

The mother board is removed together with the metal bracket. The Mother board needs to be moved out of the way to get access to the parts located in the inner-parts unit.

To remove the mother board, disconnect the following cables:

1. Disconnect the DC/DC-Mother board (red & black color) cable from the Mother board.
2. Disconnect the Battery-Mother board (red & black color) cable from the Mother board.
3. Disconnect the I/O-Mother board flat cable from the Mother board.
4. Disconnect the I/O-CPU board flat cable from the CPU board.
5. Disconnect the expansion unit-Mother board cable (if N-XNSAT, N-XOSAT, or NMT is installed).
6. Remove the 4 screws that hold the Mother board and the metal bracket to the inner-parts unit. Twist straight the metal clamp that holds the Mother board on the inner-parts unit.
7. Move the Mother board with the metal bracket out of the way.

7.3.3 ECG, NIBP, and STP board replacement

The NESTPR unit must be removed before you can replace the ECG, NIBP, or STP boards.

NESTPR unit removal

You may separate the display from the frame to gain better access to the NESTPR unit, but it is not necessary. To remove the unit without separating the display:

1. Disconnect the 5 patient-connector cables from the front panel.
Important: For reassembly, note the connection of temperature cable T1 (black wires) and, for monitors with two temperature measurements, temperature cable T2 (yellow wires). T2 is not connected for monitors that have only one temperature measurement.
2. Disconnect the NIBP tubes from the module.
NOTE: The foremost NIBP tube is connected to the upper NIBP connector.
3. Carefully lift the unit up.

ECG board replacement

1. Remove 4 screws from the ECG board and disconnect the flat cable from the STP board.
2. Detach the ECG board.

NIBP board replacement

1. To access the NIBP board, remove the ECG board.
2. Remove 4 screws from the corners of the NIBP unit.
3. Disconnect the ribbon cable from the EST board.
4. Disconnect the NIBP tubes from the adapter.
NOTE: Notice the correct tube connections; lower one to the inner one.
5. Pull the NIBP board carefully out.

STP board replacement

1. Detach the ECG board.
2. Disconnect NIBP tubes from the both sides of the plastic strut. Remove the plastic strut carefully from the NESTPR unit's frame.
3. Disconnect the ribbon cable from the STP board
4. Remove 4 screws from the corners of the STP board and detach the STP board.

7.3.4 Backplate unit removal

The backplate unit contains the fan, speaker, and I/O board

1. Remove the 3 screws that hold the backplate unit to the AC/DC unit.
2. Push the backplate unit forward and bend the retainers in both sides to loosen the unit.
3. Carefully pull out the backplate unit.
4. Disconnect the CPU-NET board cable from the I/O board.
5. Disconnect the fan power cable from the DC/DC board.
6. To remove the sample gas outlet tube, unfasten the lock washer from the gas outlet connector (X6) and pry the connector out of the cover.

7.3.5 Gas unit CPU board, pump, and fan replacement

The airway gas unit must be removed before you can replace the gas unit CPU board, the pump, or the fan.

Airway-gas unit removal

1. Move the backplate unit out of the way to access the airway gas unit (see *Backplate unit removal*).
2. Unfasten the 3 screws and washers that hold the locking chock and remove the chock.
3. If installed, disconnect the hook-and-loop strap.
4. Disconnect the 2 tubes from the rear of the airway gas unit.
5. Grip the airway gas unit and pull it out sideways.

Gas unit CPU board replacement

1. Remove 4 screws from the corners of the OM board.
2. Disconnect the following cables from the gas unit CPU board:
 - pump cable
 - pneumatics-unit cable
 - fan cable
 - TPX IR-lamp power cable
 - TPX unit ribbon cables (both)

NOTE: Use pliers to disconnect ribbon cables from the gas unit CPU board. Be careful not to bend the ribbon cable connectors.

3. Detach the gas unit CPU board from the OM board.
4. After replacing the gas unit CPU board:
 - Perform the sampling-system leak test.
 - Perform the gas calibration.

Pump unit replacement

1. Remove the screw that holds the pump unit to the airway gas unit frame. (The screw is located between the pump and the TPX unit.)
2. Disconnect the pump cable from the gas unit CPU board. Pass the cable under the pneumatic unit by lifting it.
3. Lift the pump unit off the frame.
4. Cut off the cable tie (Panduit) that holds the pump.
5. Unplug the pump hoses.

Fan replacement

NOTE: You need to detach the pump unit to access the fan power cable.

1. Detach the fan by carefully bending the fastening springs.
2. Disconnect the fan power cable from the CPU board.

7.3.6 AC/DC unit replacement

1. Remove the 3 screws that hold the AC/DC unit to the backplate unit.
2. Disconnect AC/DC-DC/DC cable from the DC/DC board.
3. Disconnect the ground wire.
4. Lift the AC/DC unit carefully up.

7.3.7 DC/DC board replacement

You may move the AC/DC unit out of the way first to improve access to the DC/DC board.

1. Disconnect the DC/DC-AC/DC board cable from the DC/DC board.
2. Disconnect the DC/DC-Mother board (red & black color) cable from the Mother board.
3. Disconnect the DC/DC-Battery cable from the DC/DC board.
4. Disconnect the Fan power cable from the DC/DC board.
5. Remove the 3 screws from the heat sink from the backside of the inner-part unit.
6. Remove the 6 screws that hold the board to the holder plate from the corners of the DC/DC board.

7.3.8 Recorder unit replacement

1. Press the recorder paper compartment release key on the front panel side.
2. Take the paper roll out.
NOTE: Be careful not to stain the thermal printer head.
3. Loosen the 2 screws in the bottom of the compartment.
4. Grab the recorder compartment and pull firmly.

NOTE: If the recorder unit is stuck in the frame, remove the recorder unit's metal cover from the backside of the front-cover unit and push the recorder out.

7.3.9 Inverter board and Backlight board replacement

1. Disconnect the CPU-Backlight board cable from the Backlight board.
2. Remove the 3 screws that hold the Backlight board to the front-cover unit.
3. Disconnect the Backlight-Inverter board cables (2 pieces) from the Inverter board.
4. Remove the Inverter and Backlight boards together.

Inverter board replacement

Remember to reassemble all the washers and the O-ring or nylon spacers. Be careful not to drive the screws so tight that you break the Inverter board.

7.3.10 CPU battery replacement



CAUTION: Discard the lithium battery according to local regulations.

Before replacing the battery, determine the monitor software version. Look on the small sticker on the rear of the monitor. The software version follows the dash after the part number (for example, in 898716-1.0, the monitor software is version 1.0; in 898716-2.4, it is version 2.4). If you cannot determine the software version from the sticker, look at the Service View screen: Press the ComWheel and select **Monitor Setup - Install/Service (16-4-34) - Service (26-23-8)**.

- For version 1.0, you must upgrade to the latest monitor software (see the *Spare Parts* chapter).
 - For version 2.4 or earlier, after replacing the battery you must reconfigure the monitor and, if the N-XNET or N-XDNET option is installed, load the N-XNET or N-XDNET software (see *Spare Parts*).
 - For version 2.5 or later, replace the battery as described below.
1. Turn off the monitor and disconnect the power cord. Remove the cover. Use a screwdriver to carefully detach the battery from the D12 circuit on the CPU board. Align and install the new battery as shown below.

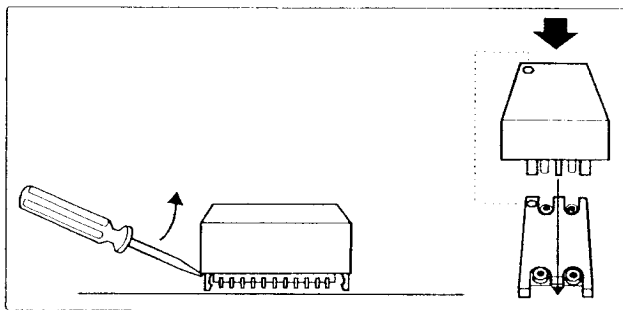

Figure 7-1. CPU battery replacement

2. Reassemble the monitor.
3. Turn on the monitor and enter the Service View screen: Press the ComWheel and select **Monitor Setup - Install/Service (16-4-34) - Service (26-23-8)**.
4. If your monitor software is version 2.5 or later, go to step 7 (perform a factory reset).
For version 2.4 or earlier, determine the frame (F-MX or F-MXG) and parameters for your monitor:
If your monitor frame is F-MXG (monitor with D-fend), select **Modules - Gas Unit - General** and determine which parameters are available.
NOTE: p&V means the same as Spirometry in Module Configurations.
5. Return to the Service View screen, select **Monitor - Configurations**, and choose the **Frame** and **Set** that correspond to your monitor.
 - There are two F-MX configurations and twelve F-MXG configurations.
 - CO₂ and N₂O are active at the same time (only CO₂ is shown in the Set configurations).
AA and ID are also active at the same time (only AA is shown in the Set configurations).
6. If applicable, load the N-XNET or N-XDNET option.
7. Perform a factory reset (from the Service View menu, select **Monitor - Factory Reset**).
8. Set the time and user configurations. See the *User's Reference Manual*.
9. Turn off the monitor for 5 minutes. Turn it on and check that the time and user configurations are **OK**.

7.3.11 CPU board replacement

Important: The new CPU board does not contain software or Network options. You must load the software after you replace the board. Refer to the *Spare Parts* chapter.

1. Disconnect the following flat cables from the CPU board:
 - CPU - REC cable
 - CPU - ComWheel cable
 - CPU - Keyboard cable
 - CPU - Display board cable
2. Remove the 6 screws that hold the CPU board to the front-cover unit.
3. Carefully remove the CPU board.

After removing the CPU board, you can access the LCD display, backlights, and keyboard.

7.3.12 LCD display, LCD display backlight, and keyboard replacement

LCD display removal

1. To remove the CPU board (and access the LCD display), disconnect the following flat cables from the CPU board:
 - CPU - REC cable
 - CPU - ComWheel cable
 - CPU - Keyboard cable
 - CPU - Display board cable

Then, remove the 6 screws that hold the CPU board to the front cover unit and carefully remove the board.

2. Remove the 2 screws that hold the display-adapter board.
NOTE: These two screws are not used if a foam backing is present.
3. Remove the 4 screws and nylon spacers that hold the LCD to the front-cover unit.
4. Lift the LCD-display unit away.

Replacing LCD display backlights

After removing the LCD display, you can replace one or both of the two LCD display backlights.

1. Remove the 2 screws that hold the backlight holder and carefully lift the holder up.
2. Replace the backlight(s).

Replacing the keyboard

After removing the LCD display, you can replace the keyboard.

Important: For reassembly, note the location of each button before replacing the keyboard.

1. Remove the 6 screws that hold the keyboard to the front-cover unit.
NOTE: Buttons are loose and may fall as you remove the keyboard.
2. Replace the keyboard and reinstall the buttons in the correct locations.
3. Install the 6 screws that secure the keyboard to the front cover unit.

7.3.13 Enhanced pulse oximetry (N-XOSAT) or SpO₂ interface board replacement

1. Disconnect the Mother board cable from the SpO₂ interface board.
2. Remove the 3 screws that secure the assembly cover to the front panel.
3. Remove the 4 screws that secure the SpO₂ interface board to the assembly cover.
4. To remove the pulse oximetry board cover from the SpO₂ interface board, gently bend the tabs to an upright position and lift the cover off.
5. Remove the 4 screws that secure the OSAT pulse oximetry board to the SpO₂ interface board and gently lift to separate the boards.
6. Disconnect the OSAT board cable from the SpO₂ interface board.
7. Disconnect the connector board/cable assembly from the OSAT pulse oximetry board.

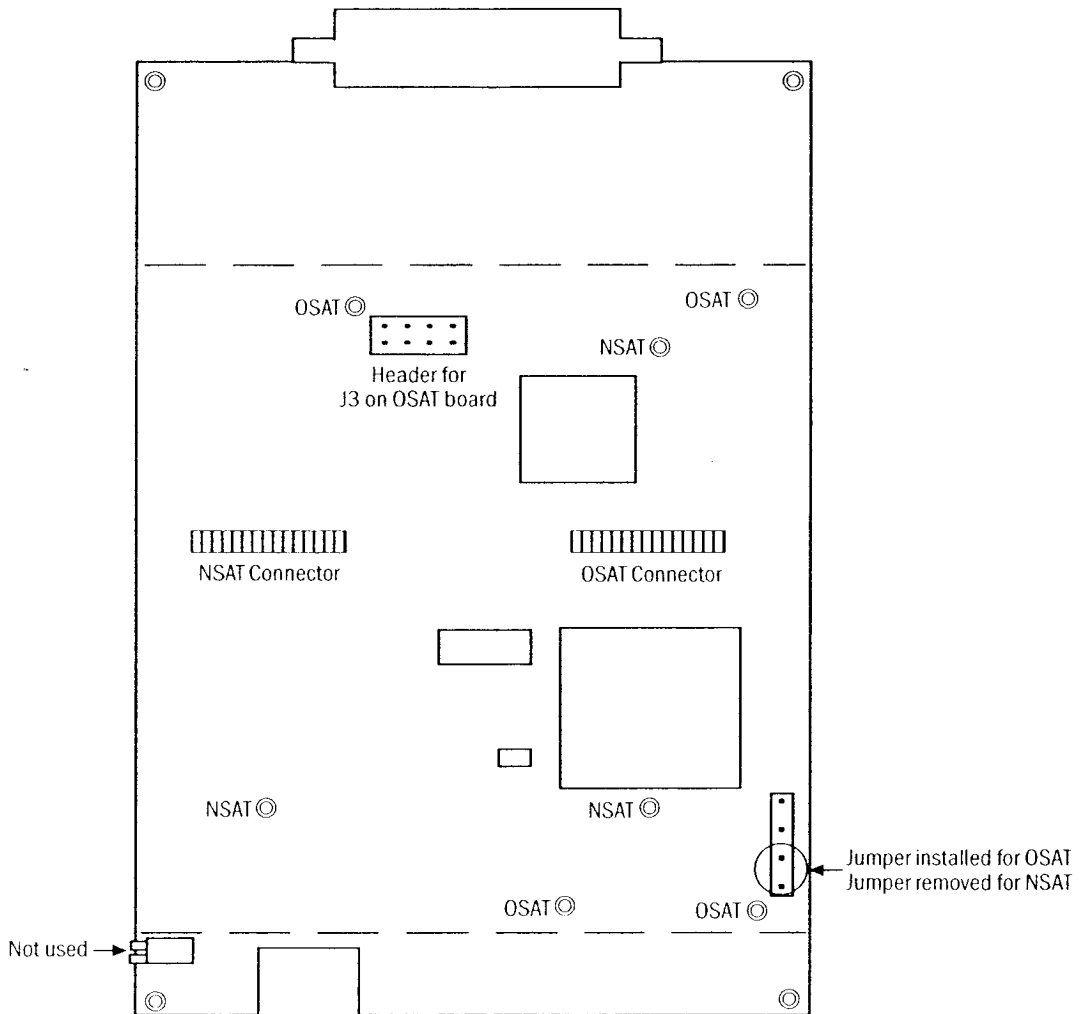

Figure 7-2. SpO₂ interface board

Installation notes (refer to figure 7-2):

- When installing the SpO₂ interface board, be sure the jumper for OSAT is installed. Transfer each standoff bushing from the old board to the new board at the four locations designated "OSAT" in figure 7-2.
- When installing the OSAT board, connect the connector board/cable assembly to the OSAT board and connect the OSAT board cable to the OSAT connector on the SpO₂ interface board. Then, align the connector J3 pins on the OSAT board with the matching header on the SpO₂ interface board. Gently press down to connect the two boards.

7.3.14 Nellcor pulse oximetry (N-XNSAT) or SpO₂ interface board replacement

1. Disconnect the Mother board cable from the SpO₂ interface board.
2. Remove the 3 screws that secure the assembly cover to the front panel.
3. Remove the 4 screws that secure the SpO₂ interface board to the assembly cover.
4. To remove the pulse oximetry board cover from the SpO₂ interface board, gently bend the tabs to an upright position and lift the cover off.
5. Remove the 3 screws that secure the NSAT pulse oximetry board to the SpO₂ interface board and gently lift to separate the boards.
6. Disconnect the NSAT board cable from the SpO₂ interface board.
7. Disconnect the connector board/cable assembly from the NSAT pulse oximetry board.

Installation notes (refer to figure 7-2):

- When installing the SpO₂ interface board, be sure the jumper on the SpO₂ interface board is **not** installed. Transfer each standoff bushing from the old board to the new board at the three locations designated "NSAT" in figure 7-2.
- When installing the NSAT board, verify that a jumper is installed on J6 (and a jumper is not installed on J5). If a jumper is installed on J5, remove it before installing the board. Then, connect the connector board/cable assembly to the NSAT board and connect the NSAT board cable to the NSAT connector on the SpO₂ interface board.

7.3.15 NMT board or NMT cable assembly replacement

1. Disconnect the Mother board cable from the NMT board (at the top of the NMT assembly located inside the front panel).
2. Remove 3 screws that secure the NMT assembly to the front panel.
3. Remove the 4 screws that secure the NMT board to the assembly cover and remove the board.
4. Disconnect the NMT input board/connector cable from X2 and X3 on the NMT board.
NOTE: Replace the old NMT board or NMT cable assembly with the new one in the steps that follow.
5. Connect the NMT input board/connector cable to the NMT board:
 - Connect the 10-pin connector to X2.
 - Connect the 3-pin stimulus connector to X3.
6. Position the NMT board in the assembly cover and install the 4 screws that secure it to the cover.
7. Position the NMT assembly over the front panel and install the 3 screws that secure it to the front panel. Be sure the NMT shield is correctly positioned under the NMT board against the front panel.
8. Connect the Mother board cable to the NMT board.

7.4 Adjustments and calibration

You use service menus to perform procedures in this section. Once you have entered the Service View menu, you can enter and exit the specific service menus at which you make the adjustments.

To enter the Service View menu, from which you access all other service menus:

1. Press the ComWheel and select **Monitor Setup**.
2. Select **Install/Service** and enter the password (16-4-34).
3. Select **Service** and enter the password (26-23-8)
The Service View menu is displayed.

NOTE: Refer to the *Service Menus* chapter for illustrations and detailed explanations of the service menus and screens.

7.4.1 Pressure safety-level detection "OFFSET"

The pressure safety-level adjustment trimmer is located on the NIBP board beside the calibration protection gear wheel. To access the pressure safety-level adjustment trimmer, you must detach the NIBP board from the NESTPR unit frame.

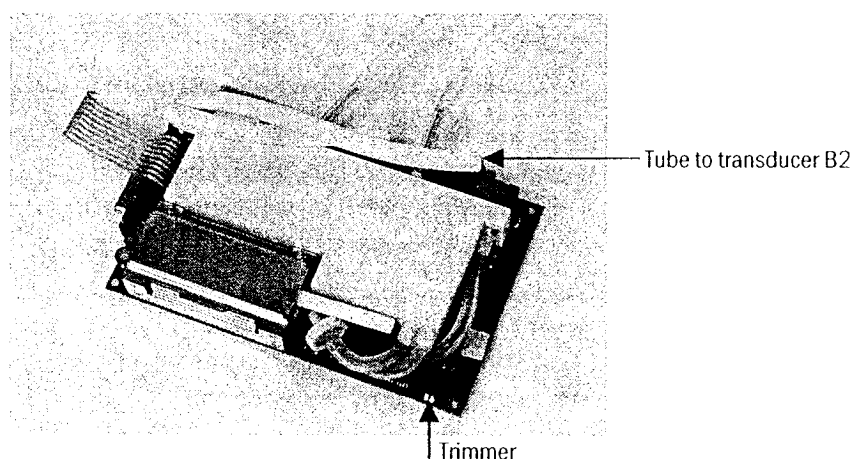

Figure 7-3. NIBP board

Tools

- Troubleshooting extension cable (884298)
1. Connect the NIBP board to the NESTPR connector on the mother board using the troubleshooting extension cable.
 2. Switch on the monitor.
 3. To enter the NIBP Pneumatics menu from the Service View menu, select:
Modules
NIBP
Pneumatics
 4. Apply 5 mmHg pressure to pressure transducer B2 with a precision manometer and adjust the trimmer to change the AD5 value on the screen from negative to positive.

7.4.2 NIBP calibration check

NIBP pressure measurement electronics are calibrated at the factory. The processor maintains zeroing pressure automatically. If the zero point of the pressure transducer drifts more than specified, an error message is given and the NIBP board should be recalibrated or replaced.

Checking the primary pressure channel calibration

1. To check the primary pressure channel calibration, press the **NIBP** key and select **NIBP Setup** to open the NIBP Setup menu.
2. If an NIBP hose is connected, disconnect it to expose atmospheric pressure to the pressure transducers.
3. Select **Calibration Check**.
Autozeroing is performed at start. The primary pressure is displayed. The zero-offset value should be zero.
4. Reconnect the NIBP hose and pressurize to 200 mmHg.

Using a manometer to check NIBP calibration

1. To enter the NIBP Calibration service menu from the Service View menu, select:
Modules - NIBP - Calibrations.
2. Set **Calibration Check** to **ON**.
3. Connect an external precision manometer to the NIBP connector.
4. Manually pump the following pressures to the NIBP tubing and check the difference between the manometer and monitor pressure display for pressure channels B1 and B2:

Pressure	Maximum Error	Example
0 mmHg	± 9 mmHg (= zero offset)	- 2
100 mmHg	$100 + \text{zero offset} \pm 2$ mmHg	98 ± 2
200 mmHg	$200 + \text{zero offset} \pm 3$ mmHg	198 ± 2

If the error for pressure channel B1 is larger than specified above, recalibrate.

The error for pressure channel B2 may be twice as large because it does not effect blood pressure measurement accuracy. When the B2 error is larger than specified above, however, recalibration is recommended to ensure the best possible operation.

7.4.3 NIBP calibration

A hole in the middle of the monitor bottom plate provides access to a gear wheel for the Temperature and NIBP calibration protection switches. Turning the gear wheel moves a slide that operates the switches.

CAUTION: Turning the gear wheel more than 1/4 turn can damage the calibration switch.

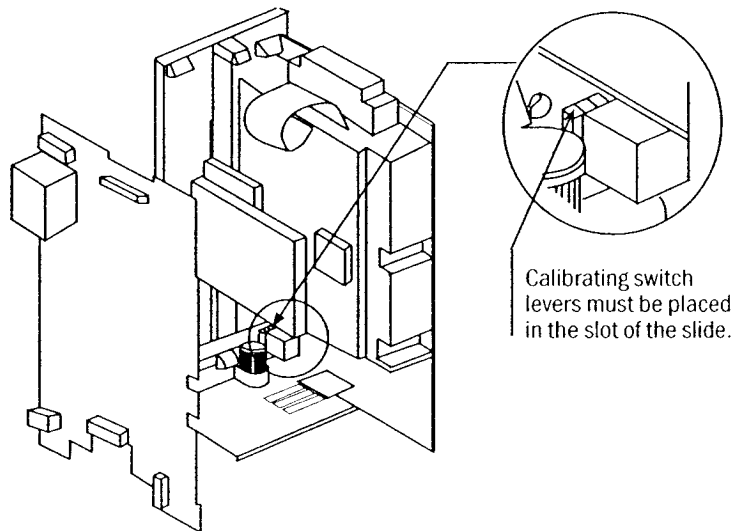

Figure 7-4. Calibration switch

1. Detach the NIBP hoses from the front panel connector to enable proper zeroing.
2. To enter the NIBP Calibration service menu from the Service View menu, select **Modules – NIBP – Calibrations**.
3. If **Protection** is **OFF** and **Calibration** is highlighted, go to step 7. Otherwise, continue with step 4.
4. Place the monitor on its left side. Insert a medium-sized, flat-head screwdriver into the hole that accesses the gear wheel for the calibration protection switches (see Figure 7-4).
5. Turn the gear wheel approximately 1/4 turn counterclockwise until **Protection** is highlighted on the screen. Select **Protection OFF** and push the ComWheel.
6. Turn the gear wheel approximately 1/4 turn clockwise until **Calibration** is highlighted. The "Calibration not protected" message appears in the NIBP digit field.
7. With **Calibration** highlighted, push the ComWheel to start the calibration. The "Zeroing" message will appear. After successful zeroing, the pressure adjustment bar will appear.
8. Connect an external mercury manometer with pump to the NIBP connector through both tubes of the hose (transducers B1 and B2 must be calibrated simultaneously). Pump up to about 200 mmHg pressure, according to the manometer, to the NIBP tubing. Calibration is possible in the range of 150 to 300 mmHg.
9. Verify that both pressure values on the screen match the manometer reading. If not, adjust by turning the ComWheel. When the values are equal, push the ComWheel to confirm the calibration. When the calibration data has been saved, the "Calibrated" message will appear.
10. Place the monitor on its left side. Insert a medium-sized, flat-head screwdriver into the hole that accesses the gear wheel for the calibration protection switches (see Figure 7-4).

11. Turn the gear wheel approximately 1/4 turn counterclockwise until **Protection** is highlighted. Choose **Protection ON** and push the ComWheel. Turn the gear wheel approximately 1/4 turn clockwise until **Calibration** and **Protection** become faint.
12. Perform the *NIBP calibration check* (earlier in this chapter) to verify the new calibration.

7.4.4 Temperature calibration

Always calibrate the temperature:

- When measured test values deviate more than ± 0.1 °C.
- After replacing the STP board.

NOTE: 25 °C and 45 °C test plugs are needed for the temperature calibration.

Tools

- Temperature calibration test plugs, 25 °C and 45 °C (884515)

1. To enter the STP Calibrations service menu from the Service View menu, select **Modules – ESTP : STP – Calibrations**
2. Place the monitor on its left side. Insert a medium-sized, flat-head screwdriver into the hole that accesses the gear wheel for the calibration protection switches (see Figure 7-4).

CAUTION: Turning the gear wheel more than 1/4 turn can damage the calibration switch.

3. Turn the gear wheel approximately 1/4 turn counterclockwise until **Protection** is highlighted on the screen. Select **Protection OFF** and push the ComWheel.
4. Turn the gear wheel approximately 1/4 turn clockwise to highlight **Calibrate T1** and choose **Calibrate T1** (or highlight **Calibrate T2** and choose **Calibrate T2**).
5. Insert a calibration plug (25 °C) into the appropriate connector (T1 or T2). Push the ComWheel.
6. Remove the plug and insert a calibration plug (45 °C) into the same connector. Push the ComWheel.
7. To reset the protection, turn the gear wheel approximately 1/4 turn counterclockwise until **Protection** is highlighted. Select **Protection ON** and push the ComWheel. Turn the gear wheel approximately 1/4 turn clockwise until **Calibration** and **Protection** become faint.

7.4.5 Invasive pressure calibration

Calibrate invasive pressure when the pressure transducer (probe) is replaced with a different type of transducer and when the STP board is replaced.

1. To enter the ESTP : STP Calibrations service menu from the Service View menu, select **Modules – ESTP : STP – Calibrations**
2. Connect a pressure transducer to the P1/P2 connector.
3. Choose **Calibrate P1** or **Calibrate P2**.
4. Expose the transducer to ambient pressure.
5. Push the ComWheel to start zeroing.
6. Connect a pressure manometer with a pump to the transducer dome. Pump a pressure of 100 mmHg to 300 mmHg to the transducer. The recommended pressure is 200 mmHg.
7. Turn the ComWheel to adjust the pressure on the display to match the pressure reading on the manometer, then push the ComWheel. A tolerance of ± 1 mmHg is allowed.

The "Calibrated" message will be displayed.

7.4.6 General checks for gas system components

These faults can occur in the sampling system:

- Leaks or blockages in the tubing.
- Sampling pump or magnetic valves failure.
- Diminished flow rates because of dirt accumulation in the internal tubing.

The following checks should help in localizing the fault. Whenever you suspect the sampling system and always after you work on the sampling system, check and (if necessary) adjust the flow rate.

CAUTION: The special internal sample tube is mechanically fragile. Sharp bends will cause leaks.

Oxygen measuring (OM) unit

CAUTION: Because of the complex and sensitive construction of the oxygen measuring unit, no repairs should be attempted inside the unit. If a fault is found in the measuring unit, the entire airway gas measurement unit should be replaced. Send the faulty unit to Datex-Ohmeda for repair.

In cases of no response to O₂ or strong drift, check the tubing for loose connections, blockages, and leaks.

CAUTION: To avoid permanent damage to the pressure transducer, never apply overpressure to the oxygen measuring unit.

If the O₂ signal is noisy, check the measurement unit suspension.

TPX measuring unit

If liquid enters the TPX measuring unit due to the failure of the water trap filter, contact Datex-Ohmeda Technical Services.

CAUTION: The TPX measuring unit can only be calibrated and repaired at the factory. In case of failure, the entire airway gas unit should be replaced and sent to Datex-Ohmeda for repair.

PVX measuring unit

The PVX unit can be replaced in case of failure.

NOTE: Never apply overpressure or negative pressure of more than 300 cmH₂O to the flow and volume tubing. Also never apply differential pressure of more than 25 mmHg on one PVX connection at a time.

Gas unit CPU board

Due to the complexity of the large-scale integrated circuitry, few faults in the CPU digital electronics can be located without special equipment. Check only that socketed ICs are properly installed.

7.4.7 Gas sampling system leak test

1. To enter the Gases service menu from the Service View menu, select **Modules – Gas Unit – Gases**
2. Prevent the monitor from performing the normal occlusion functions, such as controlling the valves, by turning the pump OFF, then ON again from the menu.
3. Open the rear cover and block the reference gas connector.
4. Connect a flow cassette with high-flow resistance (50/1.1) to the end of the sampling line.
5. Check the Amb-Work value that is displayed. When the value exceeds 170 mmHg, connect the other port of the flow cassette to the sample-gas-out connector and switch the pump off.
6. Wait until pressure inside the sampling system stabilizes, then check the Amb-Work value. The value, or pressure inside the sampling system, should not drop more than 6 mmHg in one minute.
7. If the pressure drops more, first ensure the connections you have made and then repeat the test.

7.4.8 Flow rate checks and adjustments

NOTE: Let the monitor run for 15 minutes before measuring flow rates.

A flowmeter with a low flow resistance and that is capable of measuring low flow rates is required for measuring flow rates. A sampling line of normal length must be connected to the monitor, as its length has a considerable affect on the flow.

If any flow rates are not correct, replace the D-fend water trap. Then, recheck the incorrect flows.

Flow rate checks

You check and adjust the sampling flow rate from the Gases service menu.

1. To enter the Gases service menu from the Service View menu, select **Modules – Gas Unit – Gases**
2. Wait until the **Sample Flow** value shown in the Gases service menu is near 200 ml/minute.
3. Connect a flowmeter to the 3-meter sampling line (use a 2-meter line for the N-XCAiO and N-XV options). Check that the sample flow reading on the flowmeter is within 180-220 ml/minute.
4. Connect the flowmeter to the reference gas connector on the front panel to check the reference flow of the oxygen measuring unit. Check that the reference flow reading on the flowmeter is within 31 to 45 ml/minute.

Flow rate adjustment

NOTE: Before adjusting the sampling flow, make sure there are no leaks in the sampling system.

To adjust the sampling flow rate:

1. In the Gases service menu, select Sample gain adj.
2. Turn the ComWheel counterclockwise to increase the sampling flow (clockwise to decrease). A 0.050 change in the Gain value changes the flow by approximately 10 ml/minute.
3. After you change the gain, wait until the Sample Flow value on the screen is near the original. Then, check that the sample flow (flowmeter reading) is within 180-220 ml/minute.
4. In the service menu, set the Zero valve to ON. The Sample Flow value should not change more than 20 ml/minute (30 ml/minute if the absorber is connected).
5. After adjusting the sample flow rate, connect the flowmeter to the reference gas tube. Check that the reference flow of the oxygen measuring unit (flowmeter reading) is within 31 to 45 ml/minute. This flow rate is not adjustable.

7.4.9 Spirometry leakage test and calibration

1. To enter the Spirometry service menu from the Service View menu, select **Modules – Gas Unit – Spirometry**.
2. Connect a spirometry tube to the monitor front panel connector. Connect a D-lite sensor to the tube.

Spirometry leakage test

3. Block the D-lite sampling line port with, for example, a luer stopper.
4. Grasp the D-lite and tightly occlude both ends, using your fingers or both hands to create pressure inside the D-lite.
5. Check that the **Aw Pressure** value on the Service Data screen is near 5 cmH₂O.
 - For a heavy leak, no pressure will be generated.
 - For a small leak, a pressure difference is measured, interpreted as flow, and displayed on the screen. The pressure waveform (**Aw Pressure** value) decreases slowly. The flow waveform (**Flow** value) goes above or below the zero line, depending on which connector is leaking.
6. If a leak is present, check all connectors and try again.
7. Unblock the D-lite sampling line port.

Spirometry calibration

The PVX measuring unit is calibrated at the factory. Spirometry calibration is not regularly needed in routine clinical use, but is recommended each year as part of the Planned Maintenance procedures. Perform the calibration with adult values using the D-lite and with pediatric values using the Pedi-lite. Use a calibration pump or a spirometry tester (884202). Readings are observed and adjusted from the Spirometry Service Data screen. Calibration values are saved to the EEPROM on the PVX board.

To improve accuracy, the endotracheal tube and all accessories normally in use should be attached during the calibration.

8. Connect a sampling line to the sampling line port on the flow sensor (D-lite or Pedi-lite).
9. Attach a 1-liter calibrated syringe (spirometry tester) to the flow sensor.
10. In the Spirometry service menu, select **Zero PVX** to zero the flow.
11. Select the **Sensor Type** (adult for D-lite or pediatric for Pedi-lite).
12. Pump air in, simulating a normal breathing rate, until the readings stabilize.
13. Observe the tidal volumes (**TVol Exp** and **TVol Insp** values). If both values are 1000 ml ±6% (D-lite) or 300 ml ±6% (Pedi-lite), calibration is not needed.
14. If calibration is needed, adjust the **Exp Flow Gain** and **Insp Flow Gain** values in proportion to the difference between the measured values and the spirometry tester reading:
 - Select **Exp Flow Gain**, continue to pump air in, and turn the ComWheel to increase or decrease the gain until the **TVol Exp** reading is within the specified range. Press the ComWheel to store the adjusted value.
 - Select **Insp Flow Gain**, continue to pump air in, and turn the ComWheel to increase or decrease the gain until the **TVol Insp** reading is within the specified range. Press the ComWheel to store the adjusted value.

7.4.10 Gas calibration

Perform a gas calibration every 6 months or whenever there are indications of errors in the gas readings. The time of the last calibration is shown near the bottom of the Gas Calibration menu.

Gas calibration is not available during the first five minutes of monitoring and during a gas sampling warning.

NOTE:

- During gas calibration, % units are always used for CO₂ regardless of selected measuring units.
- Anesthetic agent is always calibrated with Desflurane.

Calibration equipment and use

- Use *only* Datex-Ohmeda calibration gas to calibrate the gas measurement. Otherwise, the calibration will not succeed.
- The calibration gas container may be used until the pressure indicator reaches the red zone.
- If separate gas containers are used, each gas must be calibrated separately.
- If you use an older brass regulator, the feeding pressure should be adjusted between 5 and 7 psi. The use of an old regulator with the new aerosol containers requires an adapter available from Datex-Ohmeda. For ordering details, see the Datex-Ohmeda *Supplies and Accessories Catalog*.

NOTE: The calibration procedure for Critical Care and Anesthesia monitors is the same except that users of Critical Care monitors select **Ventilation** (not **Airway Gas**) from the Parameters menu.

1. Power on the monitor. For maximum accuracy, let the monitor warm up for 30 minutes.
2. Attach the regulator to the gas container.

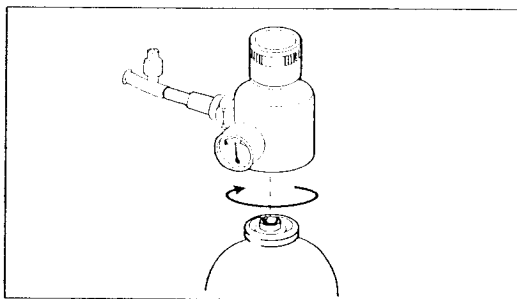

Figure 7-5. Attaching the regulator

3. Attach a new sampling line to the water trap. Connect the loose end of the sampling line to the regulator on the gas container.

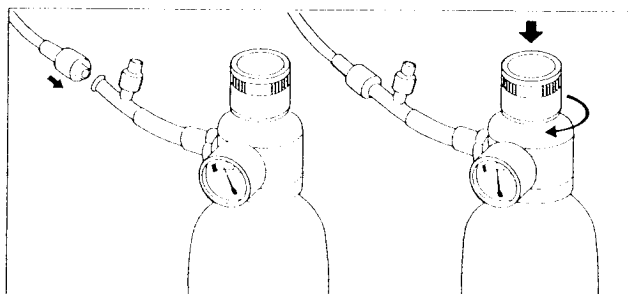

Figure 7-6. Connecting a sampling line and feeding gas

4. To enter the Gas Calibration menu, press the ComWheel and select **Parameters – Airway Gas**.
The **Gas Calibration** menu item remains gray (inactive) until the ‘Calibrating gas sensor’ message is no longer displayed.
5. Select **Gas Calibration**.
6. Wait until the ‘Zero ok’ and then ‘Feed gas’ messages appear on the screen after each gas.
If the ‘Zero error’ message is displayed, press the **Normal Screen** key and repeat the calibration procedure. If the problem persists, the unit may require service.
7. Open the regulator and feed the calibration gas until ‘Adjust’ appears, then close the valve.
NOTE: When the monitor is in automatic agent ID mode and it detects a calibration gas and no anesthetic agent (when using the Datex-Ohmeda Quick Cal calibration gas, for example), the ‘Cal gas found’ message is displayed. If the identification sensor fails, the ‘Agent id inop’ message is displayed.
8. Check that the displayed gas values match the values on the calibration gas container.

Calibration adjustments

Calibration adjustments may be required if the gas values displayed during calibration do not match the values on the calibration gas container.

If adjustments are required:

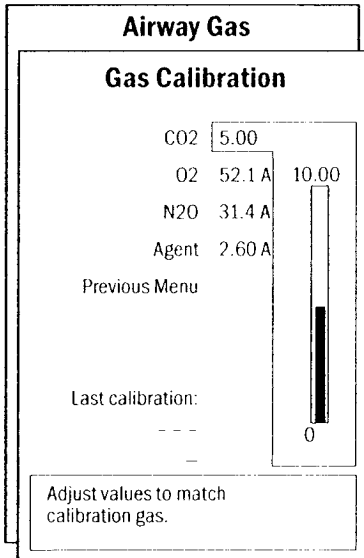

1. Select **Gas Calibration** in the Airway Gas menu.
2. Turn the ComWheel to highlight the first gas to be adjusted and press the ComWheel.
3. Turn the ComWheel until the displayed value matches the desired value. Press the ComWheel to confirm the adjustment.
4. Repeat steps 2 and 3 for each gas.

Autozeroing intervals

Autozeroing intervals after startup are as follows: every 5 minutes for the first 15 minutes, then every 15 minutes for the next 45 minutes, and every hour thereafter. Autozeroing may also occur after agent selection.

Chapter 8. Service Menus	8-1
8.1 Introduction	8-1
8.2 Entering the Service View menu	8-1
8.2.1 Service View menu and data	8-2
8.2.2 Service menu structure	8-3
8.3 Monitor menu	8-4
8.3.1 Voltages menu and data	8-4
8.3.2 Communication menu and data	8-5
Communication - Remote Access menu	8-6
8.1.3 Configuration menu	8-7
8.1.4 Watchdog Tests menu	8-8
8.1.5 Country Settings menu	8-9
8.4 Keyboard menu and data	8-10
Service Data screen	8-10
8.5 Modules menu	8-11
8.6 Gas Unit menu	8-12
8.6.1 General menu and data	8-12
General Service Data screen	8-12
8.6.2 Gases menu and data	8-13
Gases Service Data screen	8-13
8.6.3 Spirometry menu and data	8-14
Spirometry calibration	8-15
Spirometry Service Data screen	8-15
8.7 ESTP : ECG service menu and data	8-16
Service Data screen	8-16
8.7.1 ECG Setup menu	8-17
8.8 ESTP : STP service menu and data	8-18
Service Data screen	8-18
8.8.1 STP Calibrations menu	8-19
8.9 NIBP service menu, data, and checks	8-20
Service Data screen	8-20
8.9.1 NIBP Demo menu	8-21
8.9.2 NIBP Calibration menu	8-22
Active leak test	8-22

8.9.3	NIBP Safety Valve menu and data	8-23
	Safety Valve Data screen	8-23
	Safety valve test (adult/infant)	8-23
8.9.4	NIBP Pulse Valve menu and data	8-24
	Pulse Valve Data screen	8-24
	Pulse valve test	8-24
8.9.5	NIBP Buttons/Leds menu and data	8-25
	Buttons/Leds Data screen	8-25
8.9.6	NIBP Pneumatics menu and data	8-26
	Pneumatics Data screen	8-26
	Watchdog BEEP check	8-26
	Interval 20 mmHg -> 185 mmHg check	8-27
8.9.7	NIBP Watchdog menu and data	8-27
	Watchdog Data screen	8-27
	Watchdog timer tests (adult and infant)	8-27
8.10 NMT menu and data		8-28
	NMT Service Data screen	8-28
8.10.1	NMT Setup Menu	8-30
8.11 M-NSAT menu and data (N-XNSAT or N-XOSAT options)		8-31
8.12 More Modules menu		8-32
8.12.1	Memory Module menu and Module Status data	8-33
	Module Status screen	8-33
8.12.2	Memory Module menu and Communication data	8-34
	Communication screen	8-34
8.13 Service Log menu		8-35
	Error History	8-35
	Event History	8-36
	Alarm History	8-36

Table of Figures

Figure 8-1.	Service menu structure	8-3
-------------	------------------------------	-----

8. SERVICE MENUS

8.1 Introduction

This chapter contains illustrations and descriptions of the service menus that are accessed from the Service View menu. You use the service menus to check monitor functions and troubleshoot during possible failures.

The Cardiocap/5 service menu structure is similar to the service menu structure used in other Datex-Ohmeda monitors. As a result, some items in the menus are not used in the Cardiocap/5. The service data values displayed in the menu illustrations may differ depending on the monitor configuration.

NOTE: There is no service menu for the recorder (N-XREC option).

8.2 Entering the Service View menu

To enter the Service View menu:

1. Press the ComWheel and select **Monitor Setup**.
2. Select **Install/Service** and enter the password (16-4-34).
3. Select **Service** and enter the password (26-23-8).

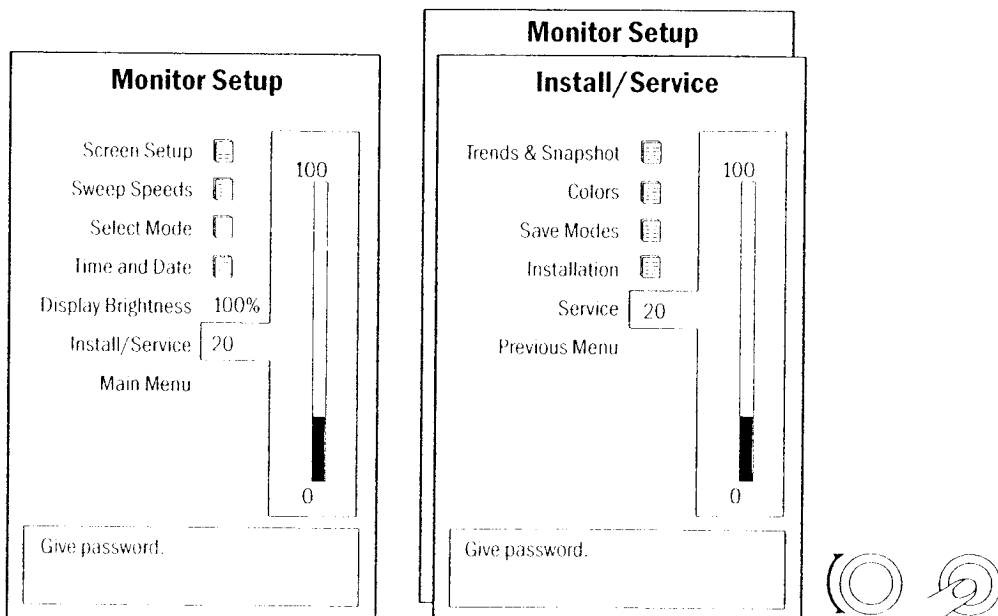

8.2.1 Service View menu and data



Scroll Vers Select this option, then turn the ComWheel to scroll the field on the right side. **-More-** indicates there are more lines to be viewed.

Record Vers Prints the software versions and other information on the recorder paper.

Sw version / Unit id screen

The field on the right shows the monitor software version, serial number (not in illustration), monitor configuration, and the release dates of different parts of the monitor. It also shows control numbers of measuring boards and serial numbers of measurement units (if available).

8.2.2 Service menu structure

NOTE: Menu items marked with * are not used in Cardiocap/5.

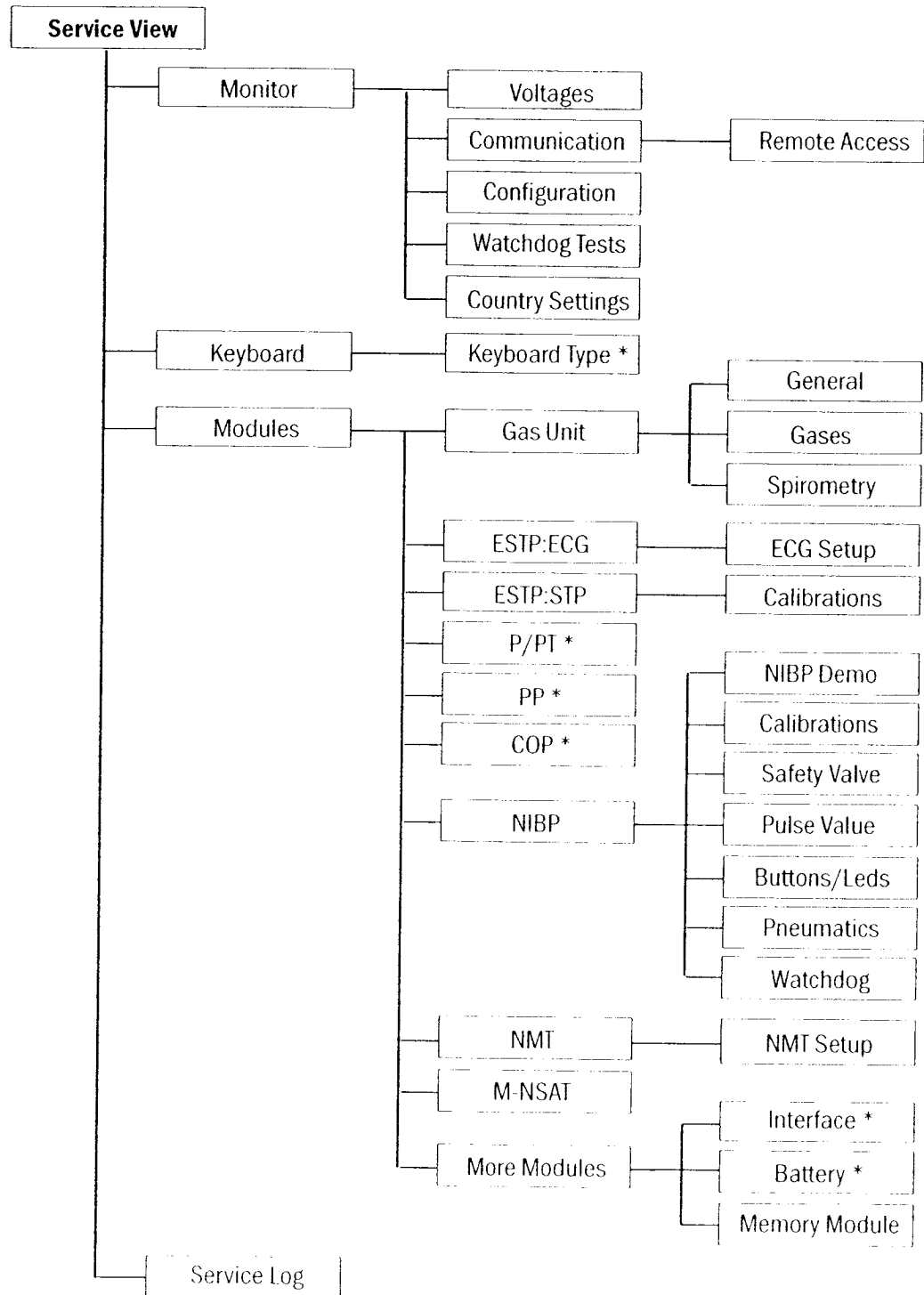
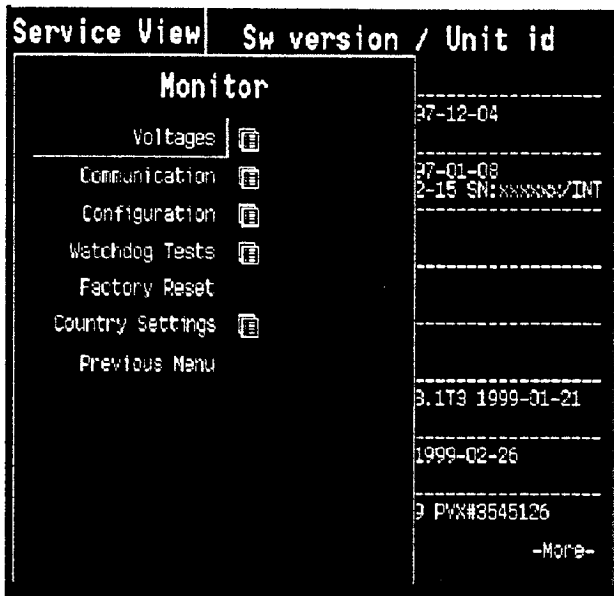

Figure 8-1. Service menu structure

8.3 Monitor menu



To enter this service menu from the Service View menu, select **Monitor**.

Factory Reset Restores factory default settings and clears data memories. Select this option if monitor software is replaced or if the SRAM/Timekeeper IC or its battery is replaced.

8.3.1 Voltages menu and data

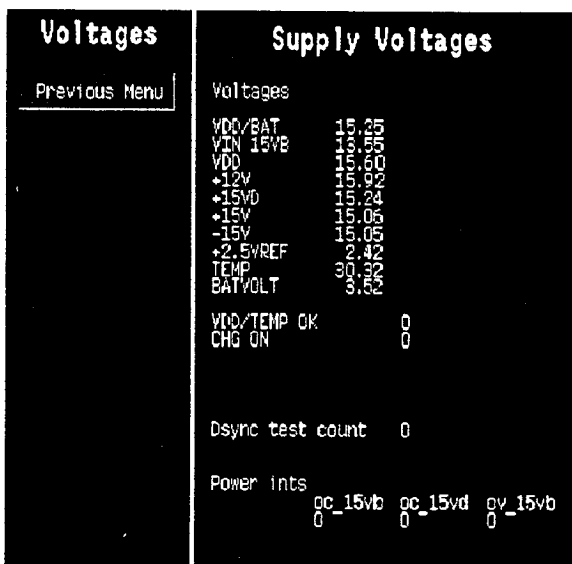

To enter this service menu from the Service View menu:

1. Select **Monitor**.
2. Select **Voltages**.

Voltages Voltages measured by the CPU board. These values are used during the planned maintenance and service checks to check each supply voltage. The numbers shown here are directive only. To get accurate voltage values these must be measured according to the instructions for the *Planned Maintenance Check* in chapter 3.

Temp (C) The internal temperature measured by the temperature sensor on the DC/DC board.

8.3.2 Communication menu and data

This service menu shows information about external communication.

Communication	Network
Network	Statistics
Computer If.	Packets In Out
Remote Access	Bytes 0 0
Previous Menu	Data errors
	CRC Frame Transm.
	0 0 0
	Hardware errors
	Intern. Missed FIFO Overrun
	0 0 0 0
	Location ID 0
	Address 004097010A3F
	Connections

To enter this service menu from the Service View menu:

1. Select **Monitor**.
2. Select **Communication**.

Network (with N-XNET or N-XDNET option) Shows information about communication with the Datex-Ohmeda Network.

- **Statistics In** shows the number of received data packets and data bytes
- **Statistics Out** shows the number of transmitted data packets and data bytes.
- **Data errors** shows the number of received erroneous data packets.

Computer If. Shows information about communication through the I/O board RS-232 serial connector (X2).

Interface status shows whether the interface through the connector is opened, active, or closed.

- **Opened** indicates that the hardware and software for the interface is running but there is no connection, or that there have been errors in using the interface.
- **Active** indicates that the interface is operating normally.
- **Closed** indicates that the necessary hardware is not present.

Communication – Remote Access menu

Use the Remote Access menu to set the interface with an external PC that runs the Virtual Support™ software, a service tool for remote diagnostics.

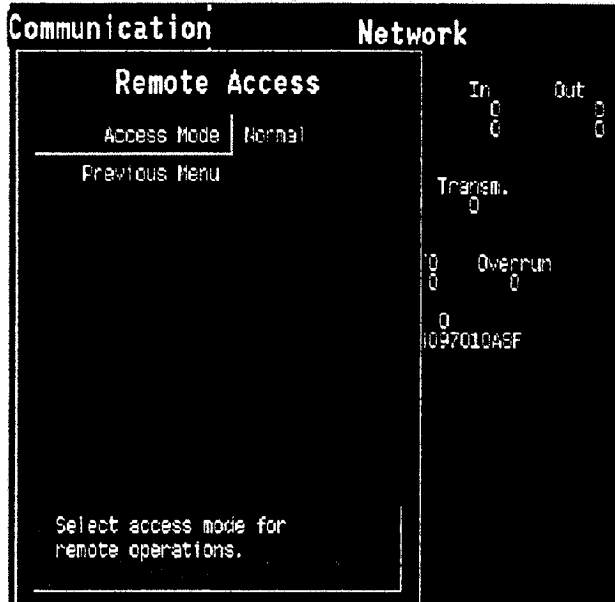

To enter this service menu from the Service View menu:

1. Select **Monitor**.
2. Select **Communication**.
3. Select **Remote Access**.

Access Mode When set to **Normal** (the default), the PC can only read service menu data from the monitor.

When set to **Extended** (future option), the PC can also activate the monitor's service menu functions.

NOTE: Patient monitoring is not possible when **Extended** is selected. The **Access Mode** returns to **Normal** if the monitor is restarted or if the service menu is closed.

8.3.3 Configuration menu

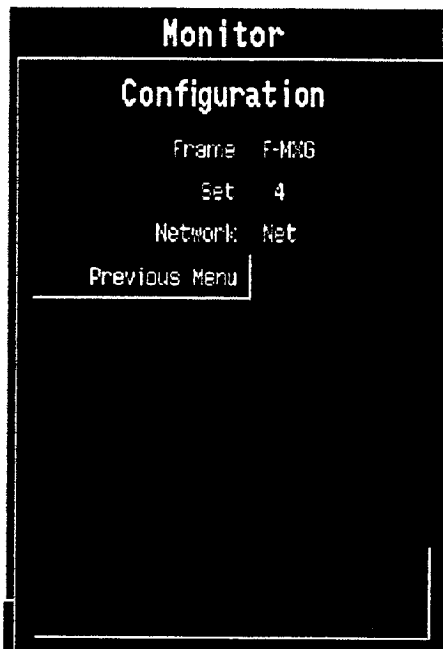

To enter this service menu from the Service View menu:

1. Select **Monitor**.
2. Select **Configuration**.

- Frame** Chooses the correct frame configuration: **F-MX** or **F-MXG**.
- Set** Chooses the parameter configuration that corresponds to the monitor hardware. The lower part of the menu screen shows the parameters included in each set.
- Network** Shows the network setting for the monitor:
- Network (Net)
 - Network and DataCard (Net+DC)
 - Neither (NONE)

8.3.4 Watchdog Tests menu

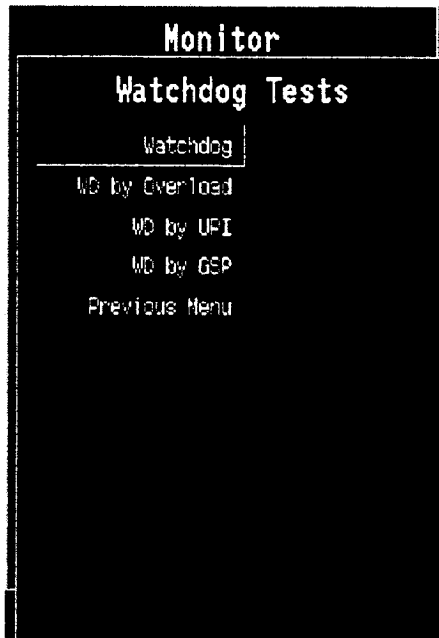

To enter this service menu from the Service View menu:

1. Select **Monitor**.
2. Select **Watchdog Tests**.

- Watchdog** This test ensures that the watchdog functions properly. This test shows running seconds with an accuracy of 0.1 seconds.
- When the safety element is working properly, the monitor restarts 1.5 seconds after the start of the test.
- In case of a malfunction, **>20 s** is displayed and the test will interrupt. In this case, the fault is in the safety element on the CPU board.
- WD by Overload** This test ensures the functionality of a feature in which the software controls the monitor and detects an overload situation in the main CPU.
- When the feature is working properly, the monitor will restart 15 seconds after the start of the test.
- WD by UFI** Not used in Cardiicap/5.
- WD by GSP** Not used in Cardiicap/5.

8.3.5 Country Settings menu

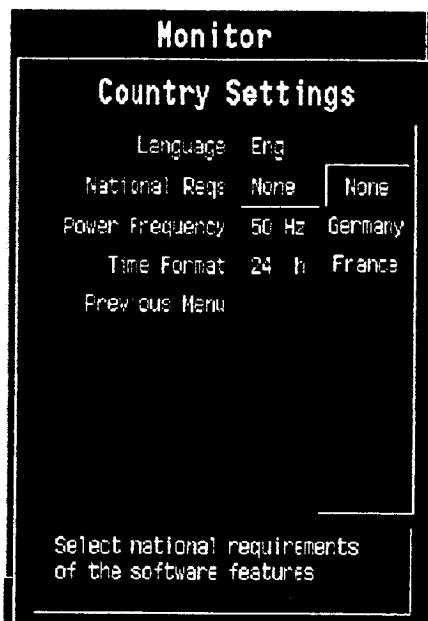

To enter this service menu from the Service View menu:

1. Select **Monitor**.
2. Select **Country Settings**.

Language	Sets the language used in this monitor.
National Reqs	Sets specific software features to fulfill national requirements in Germany or France.
Power Frequency	Sets the power frequency (50 Hz or 60 Hz). This setting is used to filter out possible power frequency interference from the parameter measurements.
Time format	Sets the time format of the real-time clock (24 h/12 h).

8.4 Keyboard menu and data

The Keyboard menu is used to test the alarm indicator LEDs and function keys.

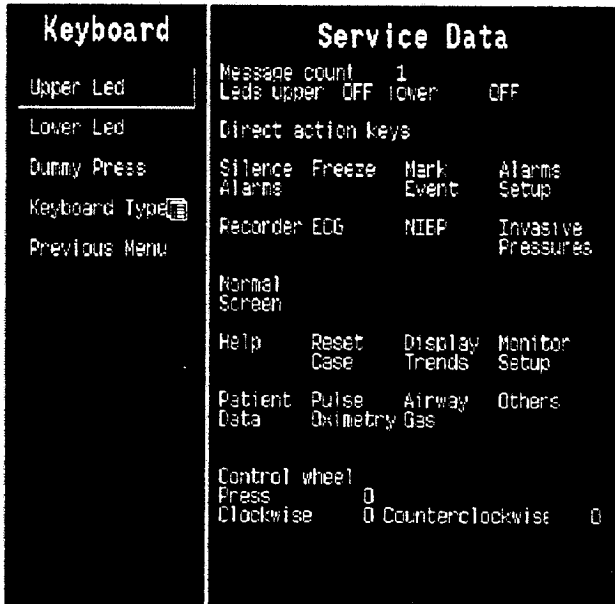

To enter this service menu from the Service View menu, select **Keyboard**.

- Upper Led** Checks upper alarm indicator LED (red).
- Lower Led** Checks lower alarm indicator LED (yellow).
- Dummy Press** Tests the function keys. See the description for *Direct action keys* below.
- Keyboard Type** Not used in Cardiicap/5.

Service Data screen

Service Data counts whenever a function is selected.

- **LEDs upper** and **LEDs lower**—indicate state of Silence Alarms LEDs.
- **Direct action keys**—items change their color when the corresponding function key is pressed. If the color does not change, the key may be mechanically damaged. Only the following checks are used in Cardiicap/5: Silence Alarms, Trends, ECG, NIBP, and Normal Screen.
- **Control wheel**— **Press** counts when the ComWheel is pushed. **Clockwise** and **Counterclockwise** count when the ComWheel is turned.

NOTE: Counters in this page are automatically zeroed when you return to the previous menu.

8.5 Modules menu

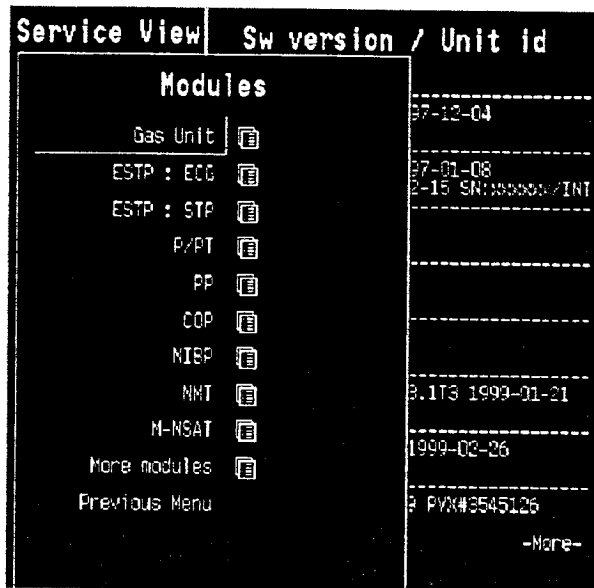

To enter this service menu from the Service View menu, select **Modules**.

The modules menu provides access to the measurement parameter menus used for the Cardiocap/5:

- Gas Unit
- ESTP: ECG
- ESTP: STP
- NIBP
- NMT
- M-NSAT (for N-XNSAT or N-XOSAT pulse oximetry option)
- More Modules

Each of these menus and screens are illustrated and described in the sections that follow.

NOTE: The **P/PT**, **PP**, and **COP** selections in the Modules menu are not used in Cardiocap/5.

8.6 Gas Unit menu

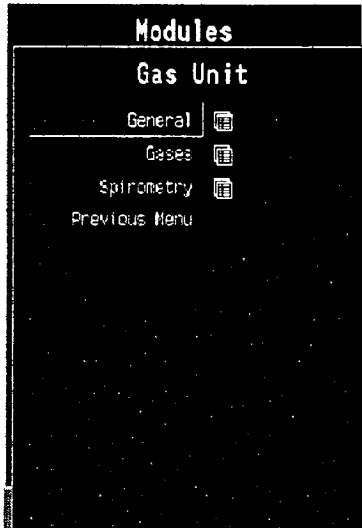

To access this menu from the Service View menu:

1. Select **Modules**.
2. Select **Gas Unit**.

8.6.1 General menu and data

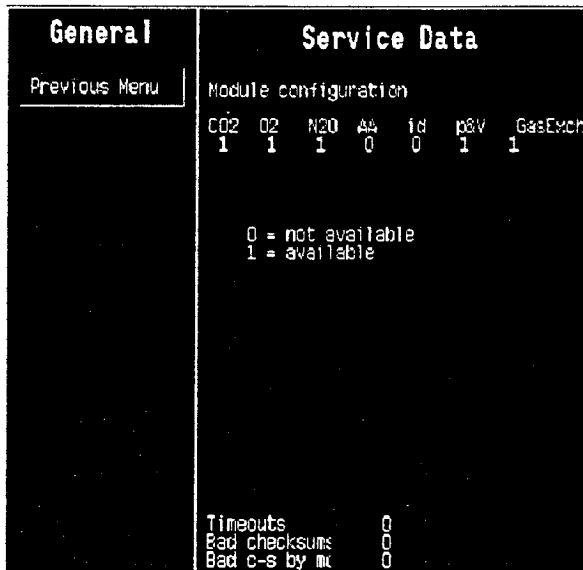

To access this menu from the Service View menu:

1. Select **Modules**.
2. Select **Gas Unit**.
3. Select **General**.

General Service Data screen

Module configuration

Shows the available measurement options (the measurement options that are detected by the measurement unit).

Timeouts, **Bad checksums**, and **Bad c-s by mod** are cumulative numbers that indicate the following:

- **Timeouts** - how many times the measurement unit did not respond to an inquiry from the CPU.
- **Bad checksums** - how many times communication from the measurement unit to the CPU broke down.
- **Bad c-s by mod** - how many communication errors the measurement unit detected.

Counting starts at power on and is reset to zero at power off. Nonzero values do not indicate a failure, but continuous counting (more than 50 per second) indicates a serial communication failure. Also, other measurement units can cause these numbers to rise.

8.6.2 Gases menu and data

Gases		Service Data			
Calibrate ID		OFF			
Noise Meas		%	noise-%	mV	Gain
Sample gain adj		O2	20.89	0.00	1.020
Fall time Meas		CO2	0.03	0.00	0.994
Pump ctrl		N2O	-0.05	0.00	1.024
Zero valve ctrl		AA1	0.00	0.00	1.000
Occl valve ctrl		AA2	---	---	---
Record Data		ID	None		
Previous Menu		ID unrel.	U		
		Sample Flow	201.4	Zero	1.9 ml/min
		Gain	1.000		
		Ambient	768	Amb-Work	68 mmHg
		OFF	Fall time	CO2	---
			CO2-O2	Delay	---
					ms
		Pump	ON	27.33	% 5625 mV
		Lamp	ON	33.42	% 1050 mA
		Fan	ON		
		Zero valve	MEAS	Occl valve	MEAS
		Temp	TPX	32.6	CPU 30.9 OM 27.1
		Time after power on			46 min

To access this menu from the Service View menu:

1. Select **Modules**.
2. Select **Gas Unit**.
3. Select **Gases**.

Calibrate ID	Not used in Cardiocap/5.
Noise Meas	Activates the noise measurement.
Sample gain adj	Adjusts the sampling pump gain (that is, adjusts the sample flow measurement).
Fall time Meas	Activates the fall time measurement.
Pump ctrl	Sampling pump manual control.
Zero valve ctrl	Zero valve manual control.
Occl valve ctrl	Occlusion valve manual control.
Record Data	Prints the shown service data and board information (id, serial number and software id.) onto the optional recorder, N-XREC.

Gases Service Data screen

O₂, CO₂, N₂O, AA	% field—real-time concentrations. noise-% field—standard deviation of concentration.
O₂, CO₂, N₂O, AA channels A-E	MV field—signal is scaled to mV. Gain field—user gain scaled as (User gain)/(Factory gain).
ID	Shows the identified agent.
ID unrel.	The shown value tells how unreliable the identification is. With pure agent the value is normally < 50.

Sample Flow	Calculated from differential pressure and adjusted by the measurement unit. Zero —value as measured during initialization when the pump is off. Gain —sample flow measurement can be calibrated by adjusting the gain.
Ambient	Ambient pressure is measured every 30 min.
Amb-Work	Ambient pressure—sampling system internal pressure.
Fall time	CO ₂ and O ₂ in ms. For N ₂ O and AA, same as CO ₂ .
CO₂-O₂ Delay	In ms. No delay between CO ₂ , N ₂ O, and agents.
Pump	Can be toggled ON/OFF. PWM output 0-100% is shown. Pump voltage is also shown.
Lamp	The state, PWM control, and current of the lamp are shown.
Fan	The state of the fan is shown.
Zero and Occl valve	Can be toggled between measurement state (MEAS) and zeroing/occlusion states (ZERO/OCCL).
Temp	Temperatures measured by the measurement unit from TPX, CPU, and OM.
Time after power on	Elapsed time in minutes after power on.

8.6.3 Spirometry menu and data

Spirometry	Service Data Adult
Sensor Type	Aw Pres Zero 217
Zero PVX	Aw Pres Gain 1133
Exp Flow Gain	Flow zero 88
Insp Flow Gain	Adult Exp Gain 1020
Valves	Insp gain 1050
VCO ₂ Gain	Common Offset 0
VO ₂ Gain	Valves MEAS
Y deadspace	zeroing enabled
N ₂ injection	Aw Pressure (cmH ₂ O) 0.0
Record Data	Ref. Condition BTPS
Previous Menu	Conv. factor Exp 0.974
	from ATP Insp 0.987
	Flow (l/min) 0.0
	TVol Exp (ml) ---
	TVol Insp (ml) ---
	MVol Exp (l/min) ---
	MVol Insp (l/min) ---
	VCO ₂ Gain 1041
	VO ₂ Gain 1057
	Y deadspace (ml) 5.0
	N ₂ injection 0
	Ambient press (mmHg) 768

To access this menu from the Service View menu:

1. Select **Modules**.
2. Select **Gas Unit**
3. Select **Spirometry**.

Sensor Type	Selects Adult or Pediatric.
Zero PVX	Starts zeroing the pressure sensors. Effects Aw Pres Zero and Flow Zero values.
Exp Flow Gain	Adjusts the exp flow sensor gain.
Insp Flow Gain	Adjusts the insp flow sensor gain.
Valves	Selects Measurement or Zeroing.
VCO₂ Gain	Adjusts the VCO ₂ gain.

V02 Gain	Adjusts the VO ₂ gain.
Y deadspace	Adjusts the Y-deadspace.
N2 injection	Selects On (1) or Off (0); setting is zero (0) during normal operation.
Record Data	Prints the shown service data and board information (id. serial number and software id.) to the recorder (N-XREC option).

Spirometry calibration

Spirometry calibration is not needed in routine clinical use, but is recommended as part of the yearly Planned Maintenance procedures. Use a calibration pump or spirometry tester to check the calibration. Check the **TVol Exp** and **TVol Insp** readings on the Spirometry Service Data screen and, if calibration is needed, adjust the flow gains accordingly. Gain scaling is 1.000 when factory settings are in effect. Calibration values are sent to the measurement unit during adjustment.

When you select **Exp Flow Gain**, **Insp Flow Gain**, **VC02 Gain**, **V02 Gain**, **Y deadspace**, or **N2 injection**, a box for adjusting the value appears. Turning the Comwheel adjusts the value. Pressing the ComWheel permanently stores the adjusted value in the measurement unit's EEPROM.

Spirometry Service Data screen

- **Aw Press Zero** and **Flow Zero** are the result of zeroing in the user service menu. They can be adjusted in the factory calibration menu, but not permanently stored.
- **Aw Press Gain** is the value used in the software. It can be adjusted, but not permanently stored.
- **Adult** (or Pediatric) sensor according to selected measurement mode (sensor).
Exp Gain and **Insp Gain** apply to the selected sensor. Exp and Insp Flow Gains are scaled as (user gain)/(factory gain). They can be adjusted in the user service menu.
- **Common Offset** is the compensation factor for the pressure-difference reading of the difference sensor when applying an equal pressure on both sides of the sensor.
- **Valves** can be changed between MEASUREMENT and ZEROING.
- **Zeroing**—automatic zeroing is either ENABLED or DISABLED (factory service menu only).
- **Aw Pressure** shows the real-time value of airway pressure.
- **Ref. Condition** shows the reference conditions in which results are located. With calibration pump or spirometry tester, the results are always in ATP. If breathing is detected (EtCO₂ > 1.0 %), results are according to Flow & Vol Setup selection.
- **Flow** shows the flow measurement value.
- **TVol Exp**, **TVol Insp**, **MVol Exp**, and **MVol Insp**—the values shown on this screen are the same as the values shown on the main display.
- **VC02 Gain** and **V02 Gain**—Not used in Cardiocap/5.
- **Y-deadspace** is the geometric volume in ml between the Y-piece and the D lite. Default is 5 ml for a standard Y-piece (as delivered with Siemens 900C ventilators). Used for VCO₂ and VO₂ delay time corrections.
- **N2 injection**—set it to 1 during laboratory tests with a spirometry tester and injection of N₂ gas (for scientific validations use only). At power on and during normal use, the value is always zero.
- **Ambient press** shows the ambient pressure in mmHg.

8.7 ESTP : ECG service menu and data

ECG Module	Service Data
ECG Setup 	Power freq 50 Hz
Power Freq	Filter low 0.05 Hz high 30 Hz
Filter Low	Cable type 5 lead
Filter High	Quick zero OK ON ON
Previous Menu	Cable OFF
	Electrode RA LA LL V RL
	OFF OFF OFF OFF OFF
	Pacer count 3
	Button OFF
	Resp Available OFF
	Measurement ON
	Amp zero OFF
	Value ---
	Timeouts 0 RAM OK
	Bad checksums 0 ROM OK
	Bad c-s by mod 0 EEPROM OK

To enter this service menu from the Service View menu:

1. Select **Modules**.
2. Select **ESTP : ECG**.

Power Freq Sets power frequency; 50 Hz/60 Hz.

Filter Low Sets filter low frequency; 0.05 Hz/0.5 Hz.

Filter High Sets filter high frequency; 30 Hz (40 Hz if power freq is 60 Hz) / 100 Hz or 150 Hz

Service Data screen

Power freq and Cable type show the values chosen or detected.

Filter low and high defines the selected filter (Monitor/Diagnostic/SI).

Quick zero is ON when the signal in any of the three internal amplifiers goes beyond scale, and therefore, a capacitor connected to the related channel discharges overvoltage. At least one **Quick zero** value is OFF when using a 3-lead cable; all three are OFF when using a 5-lead cable. **Quick zero** also takes place when the lead is changed in 3-lead measurement.

Cable shows ON when an ECG cable is connected.

Electrode shows ON when each of these electrodes are connected.

Pacer count is a running number for pacemaker users.

Button is not used in Cardiicap/5.

Resp Available indicates that ECG hardware is capable of measuring impedance respiration.

Measurement shows ON when the respiration measurement is ON.

Amp Zero shows ON when zeroing of the respiration amplifier takes place.

Waveform **Value** will be updated in one-second intervals.

For definitions of **Timeouts**, **Bad checksums**, **Bad c-s by mod**, **RAM**, **ROM**, and **EEPROM**, see *NIBP service menu, data, and checks* later in this chapter.

8.7.1 ECG Setup menu

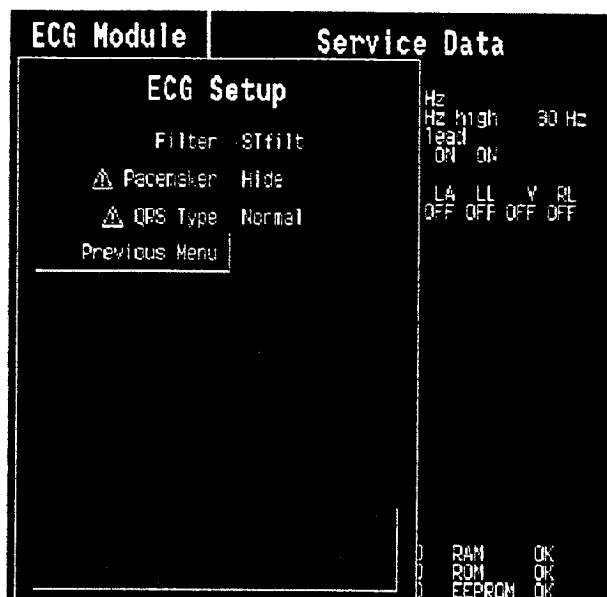

To enter this service menu from the Service View menu:

1. Select **Modules**.
2. Select **ESTP : ECG**.
3. Select **ECG Setup**.

- Filter** Filters the ECG signal high-frequency noise and slow-respiratory artifacts.
- Monit** (monitor) filter is used in routine monitoring. It effectively filters the artifacts caused by the electrosurgery unit and respiration.
- Diagn** (diagnostic) filter is used if more accurate waveform information is needed (of P-wave or AV block, for example). The diagnostic filter is more susceptible to high frequencies and baseline wander than the monitor filter.
- STfilt** (ST filter) permits more accurate information of ST segment. It filters the high-frequency artifacts caused by electrosurgery unit but catches the slow changes in ST segment. The ST filter is more susceptible to baseline wander than the monitor filter.
- Pacemaker** Selects how to display the pacing pulse of a cardiac pacemaker. The selections are **Show**, **Hide**, **ON R** and **Sensit**.
- Hide** filters the pacing pulse away from ECG data.
- Show** filters the pacing pulse away from ECG data but the pulse is displayed as a constant height marker.
- ON R** does not filter pacing pulses away from ECG data. This improves ECG monitoring with A-V pacemaker patients, as QRS complexes are counted even if the pacing pulse hits the QRS complex. During asystole pacing pulses may be counted as heartbeats.
- Sensit** uses more sensitive pacemaker detection. Pacemaker spike is displayed on ECG.
- QRS Type** QRS detection and HR calculation may be affected by the shape of the QRS complex.
- Normal** QRS Type detects a heartbeat between 40 and 120 ms.
- Wide** QRS Type detects a heartbeat between 40 and 220 ms.

8.8 ESTP : STP service menu and data

ESTP Module	Service Data			
Calibrations	Gain	P1	P2	T1 T2
Record Data	Zero	-1	-15	105 109
Temp Test	Cable	OFF	OFF	OFF OFF
Previous Menu	Probe	OFF	OFF	OFF OFF
	Value	---	---	---
	Buttons	OFF	OFF	OFF
	SpO2	---	Ined int.	250
	Modpr	---	Red int.	250
	Hr	---	DC gain	45
	Cable	ON	IDC	1962
	Probe	ON	RDC	1956
	Probe off		AC gain	0
			Pre gain	1
	Temp error		ON	ON
	Temp test		OFF	
	Protect key		OFF	
	Protect mode		ON	
	Configuration		STP	
	Timeouts		0	RAM OK
	Bad checksums		0	ROM OK
	Bad c-s by mod		0	EEPROM OK

To enter this service menu from the Service View menu:

1. Select **Modules**.
2. Select **ESTP : STP**.

Record Data Records, or prints, the service data shown and board information (ID, serial number and software ID) on the recorder paper.

Temp Test Activates the automatic temperature test for temperature channels T1 and T2. The result appears in the service data screen. NOTE: Select **Temp Test** twice to start the test.

Service Data screen

Gain is a coefficient to compensate gain error. Usually, P1 and P2 values are between 17,000 and 25,000; the T1 and T2 values are between 13,000 and 14,300. Calibrate if any gain value is outside the range.

Zero indicates the offset compensation value of each parameter in the A/D converter. Typically, P1 and P2 values are within ± 1000 ; the T1 and T2 values are between -150 and +300. Calibrate if any zero value is outside the range.

Cable shows ON when a corresponding cable is connected to the front panel.

Probe shows ON when a corresponding probe is connected to the **Cable**.

Value shows the measured numeric values simultaneously. Pressure values are real time values shown in mmHg. Temperature values are shown in degrees Celsius.

Buttons is not used with Cardiicap/5.

SpO₂ shows the measured beat-to-beat SpO₂ value.

Modpr is a modulation % that indicates AC/DC ratio in the measured signal.

Hr is a pulse rate calculated from every beat.

Cable and **Probe** can be either OFF or ON. They indicate the Probe Off state. Under **Probe**, an SpO₂ message field displays status messages, such as OK, Pulse search, No probe, Probe Off, No pulse, Artifact, Poor signal, or Check probe.

red int. (infrared intensity) range is 40 to 255 and **Red int.** (red intensity) range is 40 to 255.
 NOTE: Balance between LEDs is adjusted by changing the infrared/red intensity.

DC gain shows the adjusted DC signal gain.

IDC is the value of the infrared signal and **RDC** is the DC value of the red signal.

AC gain is the gain of infrared and red AC signals. AC gain values can be 1 (high gain) or 0 (low gain).

Pre gain is a preamplifier gain for infrared and red signals. Pre-gain values can be 1 (normal operation) or 0 (signal levels are very low and extra gain is taken into use).

Temp error shows the status of the temperature test: ON (errors found) or OFF (no errors found).

Protect key is normally OFF. It turns to ON when the button at the bottom of the module is pressed.

Protect mode is normally ON. It turns to OFF when Protection is switched to OFF for temperature calibration in the STP Calibrations service menu.

Configuration shows the chosen module configuration: TP, ST, or STP.

For definitions of **Timeouts**, **Bad checksums**, **Bad c-s by mod**, **RAM**, **ROM**, and **EEPROM**, refer to *NIBP service menu, data, and checks* later in this chapter.

8.8.1 STP Calibrations menu

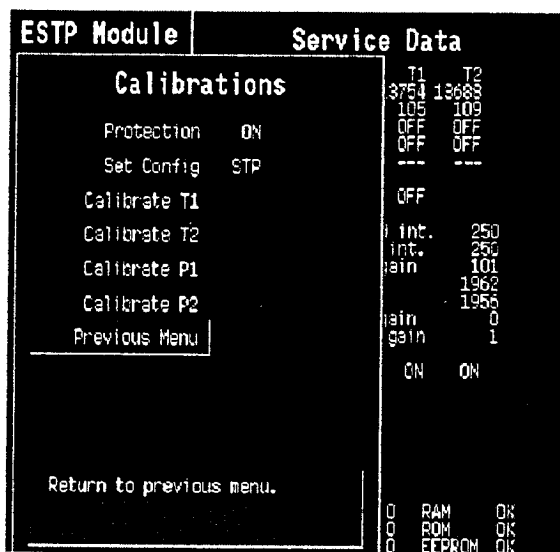

To enter this service menu from the Service View menu:

1. Select **Modules**.
2. Select **ESTP : STP**.
3. Select **Calibrations**.

Protection Protects the configuration and temperature calibrations. Can be set ON (protected) and OFF only when protect button at the bottom of the module is pressed.

Set Config Sets the configuration to TP, ST, or STP. The setting is possible only when Protection is OFF. This setting should be checked if the STP board is replaced.

Calibrate T1 / Calibrate T2

Calibrates temperature channels T1 or T2. Calibration is possible only when Protection is OFF. Accurate test plugs of 25 °C and 45 °C values are required. See *Temperature calibration* in the *Service Procedures* chapter.

Calibrate P1 / Calibrate P2

Calibrates the invasive blood pressure channels P1 and P2. A pressure transducer (with an appropriate cable) and a pressure manometer are required. See *Temperature calibration* in the *Service Procedures* chapter.

8.9 NIBP service menu, data, and checks

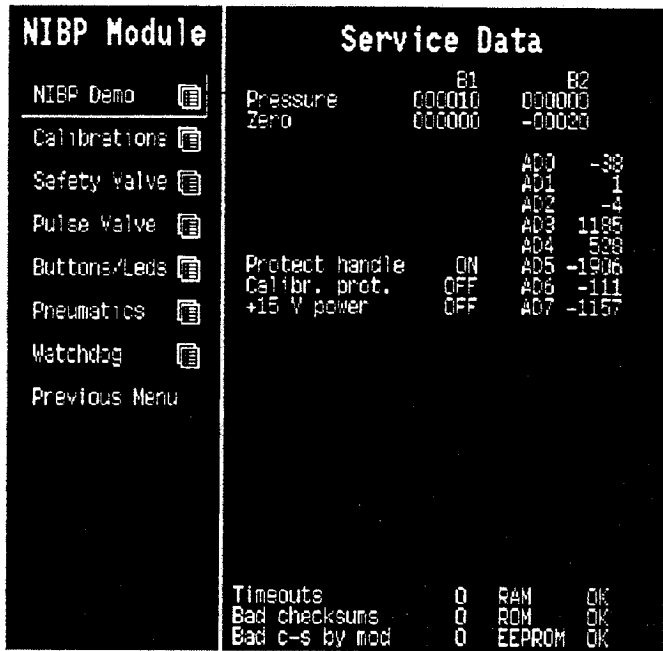

To enter this service menu from the Service View menu:

1. Select **Modules**.
2. Select **NIBP**.

The submenus shown in this menu (**NIBP Demo**, **Calibrations**, etc.) are described later in this section.

Previous Menu Closes this menu and displays the previous menu.

Service Data screen

Pressure Measured pressure multiplied by 10.

Zero Pressure at auto zeroing multiplied by 10 and changes between +20 and -20 mmHg. Absolute pressure is the sum of **Pressure** and **Zero**.

Protect handle Hardware protection for EEPROM memory (always ON during normal operation). If it is OFF, data cannot be read from or written to EEPROM; only the calibration protection can be set or reset by software. You can change the protection setting in the **Calibration** menu by turning the gear wheel (located inside a small hole in the bottom of the monitor) to enable **Protection ON/OFF**.

Calibr. prot. Software calibration protection. It should be OFF to enable calibration.

+15 V power The condition of the +15 V dirty supply voltage for the pump and valves. It exists (ON) or not (OFF), depending on service menu function. The supply voltage can be turned ON by selecting the previous Menu and then the desired menu again.

AD0 ... AD7 The values of each of the eight A/D converter channels.

Timeouts, **Bad checksums**, and **Bad c-s by mod** are cumulative numbers that indicate the following:

Timeouts—how many times the module did not respond to an inquiry from the monitor.

Bad checksums—how many times communication from the module to the monitor failed.

Bad c-s by mod--how many communication errors the module detected.

Counting starts at power up and resets to zero at power off. Nonzero values do not indicate a failure, but continuous counting (more than 50 per second) indicates a serial communication failure or that the module is not installed. Other modules can cause communication errors that cause these numbers to rise.

RAM	The state of RAM memory.
ROM	Indicates whether the checksum in EPROM is in accordance with the one the software calculated.
EEPROM	Indicates if the values stored in permanent memory are valid. The state is either OK , Fail , or ? (communication error or module is not installed).

8.9.1 NIBP Demo menu

This service menu is used for demonstrating the oscillometric method of NIBP measurement. The menu shows the real-time pressure signals that are measured from the NIBP cuff. The measurement result is shown in the adjoining digit field.

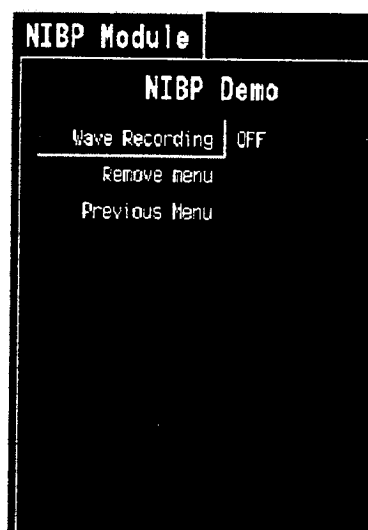

To enter this service menu from the Service View menu:

1. Select **Modules**.
2. Select **NIBP**.
3. Select **NIBP Demo**.

Wave Recording Selects the recording option. If ON is selected, the pressure signals are recorded in real time onto the recorder paper.

Remove menu Widens the displayed waveform area.

Previous Menu Closes this menu and displays the previous menu. If **Remove menu** was selected, you can also just press the ComWheel.

8.9.2 NIBP Calibration menu

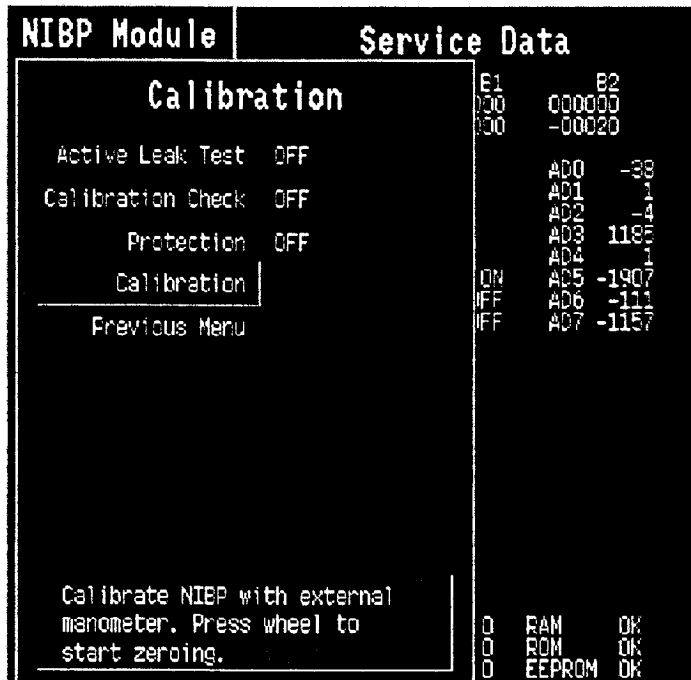

To enter this service menu from the Service View menu:

1. Select **Modules**.
2. Select **NIBP**.
3. Select **Calibrations**.

- Active Leak Test** Tests for leaks.
- Calibration Check** Checks the calibration.
For details, see *NIBP calibration check* in the *Service Procedures* chapter.
- Protection** Software calibration protection (ON/OFF). When calibrating, Protection should be OFF. To change the Protection, you must activate the menu item by turning the gear wheel (located inside a small hole in the bottom of the monitor).
For details, see *NIBP calibration* in the *Service Procedures* chapter.
- Calibration** Calibrates NIBP. This selection is available only when Protection is OFF.
For details, see *NIBP calibration* in the *Service Procedures* chapter.

Active leak test

1. Wrap an adult cuff around a stable cylindrical object (to simulate an arm) and connect the cuff to the monitor.
2. Select **Active Leak Test ON**. Pressure of 260 mmHg is pumped into the cuff automatically.
3. Wait for several seconds until the pressure stabilizes. If the pressure reading drops more than 5 mmHg per minute, detect and fix leaking point(s).
4. Cancel the test by selecting **Active Leak Test OFF**.

8.9.3 NIBP Safety Valve menu and data

Safety Valve		Safety Valve Data			
ADULT		B1	B2		
Start Test		Pressure	000000	000000	
Previous Menu		Zero	000000	-00020	
			AD0	-38	
			AD1	1	
			AD2	-4	
			AD3	1185	
			AD4	1	
		Protect handle	ON	AD5	-1907
		Calibr. prot.	OFF	AD6	-111
		+15 V power	ON	AD7	-1157
			B1	B2	
		Max press	0	0	
		2 s after stop	0	0	
		Timeouts	0	RAM	OK
		Bad checksums	0	ROM	OK
		Bad c-s by mod	0	EEPROM	OK

To enter this service menu from the Service View menu:

1. Select **Modules**.
2. Select **NIBP**.
3. Select **Safety Valve**.

Start Test Starts the Safety Valve Test; changes to **Stop Test** after you start the test.

Safety Valve Data screen

See *NIBP service menu, data, and checks* earlier in this chapter for information on Pressure, Zero, Protect handle, Calibr. prot., +15 V power, AD0 to AD7, Timeouts, etc.

Max. press and **2 s after stop** show the measured values at Safety Valve test.

Max. press The pressure at which the safety valve opens. It is normally 310 ± 15 mmHg for adult and 150 mmHg ± 15 mmHg for infant.

2 s after stop The pressure at 2 seconds after the pump has stopped. It is normally >280 mmHg for adult and >120 mmHg for infant. If the value is less, check leakage by the active leak test.

Safety valve test (adult/infant)

Wrap an adult cuff around a pipe and connect the cuff to the monitor. Choose **Start Test** and push the ComWheel. The test ends automatically or when you select **Stop Test**.

8.9.4 NIBP Pulse Valve menu and data

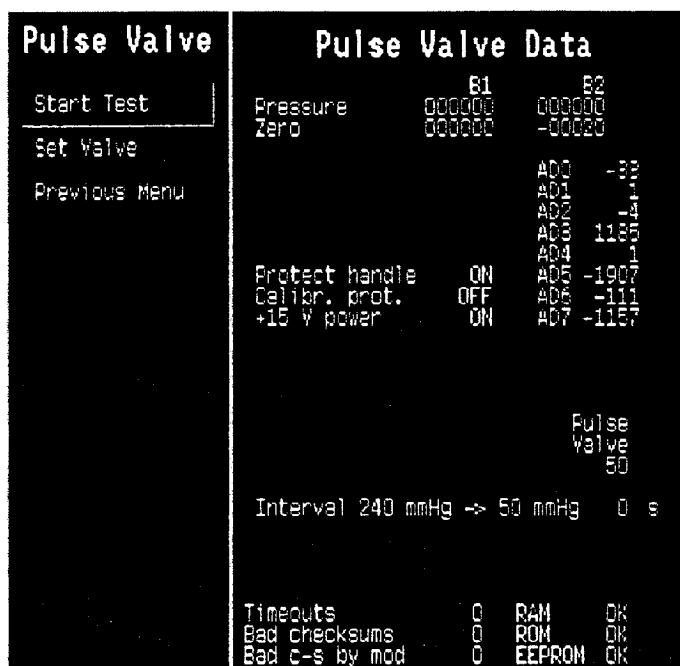

To enter this service menu from the Service View menu:

1. Select **Modules**.
2. Select **NIBP**.
3. Select **Pulse Valve**.

Start Test Starts the Pulse Valve test; changes to **Stop Test** after you start the test.

Set Valve Lets you adjust the opening of the pulse valve.

Pulse Valve Data screen

See *NIBP service menu, data, and checks* earlier in this chapter for information on Pressure, Zero, Protect handle, Calibr. prot., +15 V power, AD0 to AD7, Timeouts, etc.

Pulse valve test

1. Wrap an adult cuff around a pipe and connect the cuff to the monitor.
2. Choose **Start Test** and push the ComWheel.

The pressure rises beyond 240 mmHg and stops. The pulse valve opens. The time it takes for the pressure to go from 240 mmHg to 50 mmHg is counted and displayed on the screen.

3. To stop the test, select **Stop Test**.

The valve can be adjusted between 0 (fully closed) and 255 (fully open). To adjust, choose **Set Valve** and push the ComWheel. Adjust the pulse-valve value by turning the ComWheel, then push it to set the value.

The **Interval 240 mmHg -> 50 mmHg** time should be less than 60 seconds when the valve is 150, and less than 10 when fully opened (255). When fully closed (0), the system should be airtight and the pressure does not drop. Depending on an individual, the pulse valve may remain closed up to 100, approximately.

If the measured time deviates much from those above, then the pulse valve or its tubes are faulty.

8.9.5 NIBP Buttons/Leds menu and data

Buttons/Leds		Buttons/Leds Data			
Auto	ON	Pressure	B1 000000	E2 000000	
Manual	ON	Zero	000000	-00000	
STAT	ON			AD0	-98
Measur.	ON			AD1	-100
Previous Menu				AD2	-101
				AD3	1188
		Protect handle	ON	AD4	-100
		Calibr. prot.	OFF	AD5	-111
		+15 V power	ON	AD6	-1157
				AD7	-1157
		Auto On/Off	OFF	Set Cycle Time	OFF
		STAT On/Off	OFF	Start Cancel	OFF
		Timeouts	0	RAM	OK
		Bad checksums	0	ROM	OK
		Bad c-s by mod	0	EEPROM	OK

To enter this service menu from the Service View menu:

1. Select **Modules**.
2. Select **NIBP**.
3. Select **Buttons/Leds**.

The Auto ON/OFF, Manual ON/OFF, STAT ON/OFF, and Measur. ON/OFF menu selections have no effect.

Buttons/Leds Data screen

See *NIBP service menu, data, and checks* earlier in this chapter for information on Pressure, Zero, Protect handle, Calibr. prot., +15 V power, ADO to AD7, Timeouts, etc.

The **Auto On/Off** and **Start Cancel** fields are not used with Cardiocap/5.

8.9.6 NIBP Pneumatics menu and data

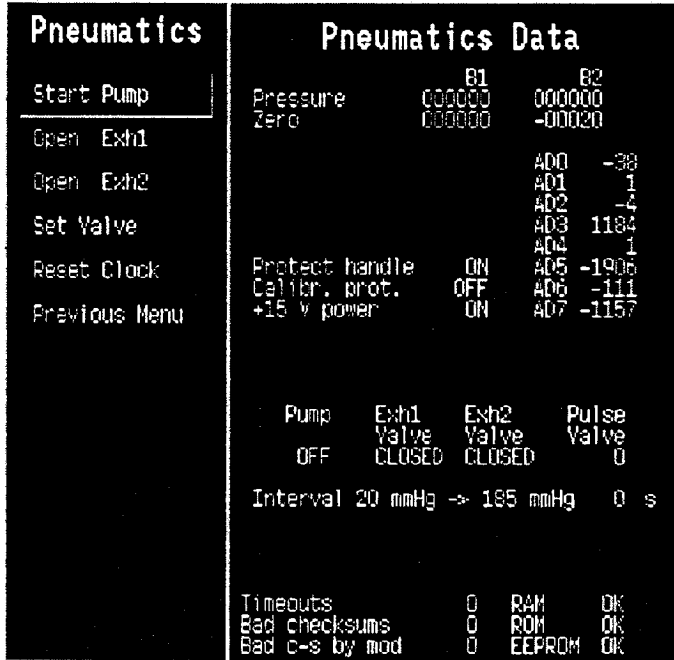

To enter this service menu from the Service View menu:

1. Select **Modules**.
2. Select **NIBP**.
3. Select **Pneumatics**.

- Start Pump** Starts the pump; changes to **Stop Pump** when the pump is on.
- Open Exh1** Opens exhaust valve 1; changes to **Close Exh1** when the valve is open.
- Open Exh2** Opens exhaust valve 2; changes to **Close Exh2** when the valve is open.
- Set Valve** Adjusts the pulse-valve opening between 0 (fully closed) and 255 (fully open). To adjust, push the ComWheel, turn it to adjust the value shown on the screen, and push it to set the value.
- Reset Clock** Zeros the time on the display.

Pneumatics Data screen

See *NIBP service menu, data, and checks* earlier in this chapter for information on Pressure, Zero, Protect handle, Calibr. prot., +15 V power, AD0 to AD7, Timeouts, etc.

Pump shows the state of the pump (ON/OFF).

Exh1 Valve and **Exh2 Valve** show the states of exhaust valve 1 and exhaust valve 2 (OPEN/CLOSED).

Pulse Valve shows how much the valve is opened (0 to 255) during Valve Setting.

Watchdog BEEP check

Connect a manometer to the front panel and pump in pressure. When the AD5 value changes from a negative value to a positive value (at about 5 mmHg), a beep sounds. This is the watchdog threshold pressure. Beyond this pressure the watchdog is active and cuts pressure at about 2 minutes (adult).

Interval 20 mmHg -> 185 mmHg check

1. Wrap an adult cuff around a pipe and connect the cuff to the monitor.
2. Select **Start Pump** at different combinations of the valves open/closed and push the ComWheel.
The time it takes for the pressure to go from 20 mmHg to 185 mmHg is counted and displayed. When all valves are closed, the pump should pump the pressure in about 1 to 4 seconds.
3. To stop the pump, choose **Stop Pump** and push the ComWheel.

8.9.7 NIBP Watchdog menu and data

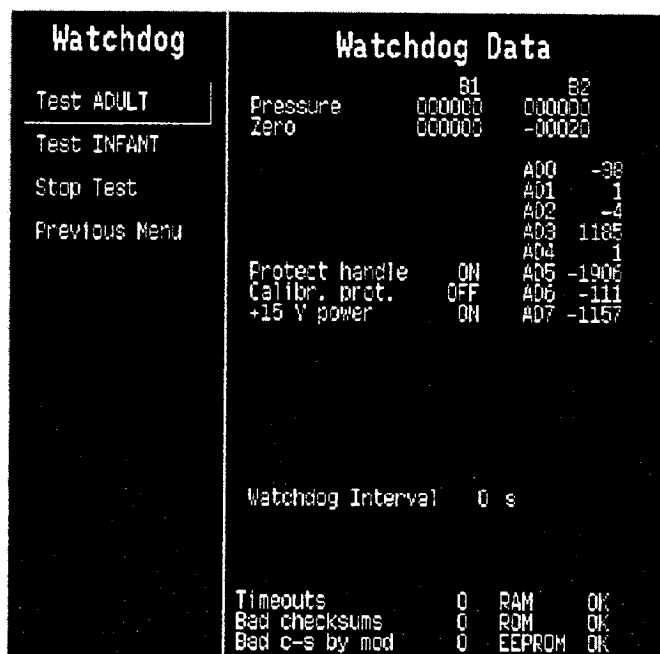

To enter this service menu from the Service View menu:

1. Select **Modules**.
2. Select **NIBP**.
3. Select **Watchdog**.

Test ADULT Tests the watchdog timer in adult mode (120 to 140 seconds).

Test INFANT Tests the watchdog timer in infant mode (about 60 to 70 seconds).

Stop Test Stops the test.

Watchdog Data screen

See *NIBP service menu, data, and checks* earlier in this chapter for information on Pressure, Zero, Protect handle, Calibr. prot., +15 V power, AD0 to AD7, Timeouts, etc.

Watchdog Interval shows the time the +15 Vdirty stays on during the test.

Watchdog timer tests (adult and infant)

Choose **Test ADULT** and push the ComWheel. Watchdog interval starts counting seconds and continues counting as long as the +15 Vdirty is on. The time should be 120 to 140 seconds.

Choose **Test INFANT** and push the ComWheel. Watchdog interval starts counting seconds and continues counting as long as the +15 Vdirty is on. The time should be 60 to 70 seconds.

8.10 NMT menu and data

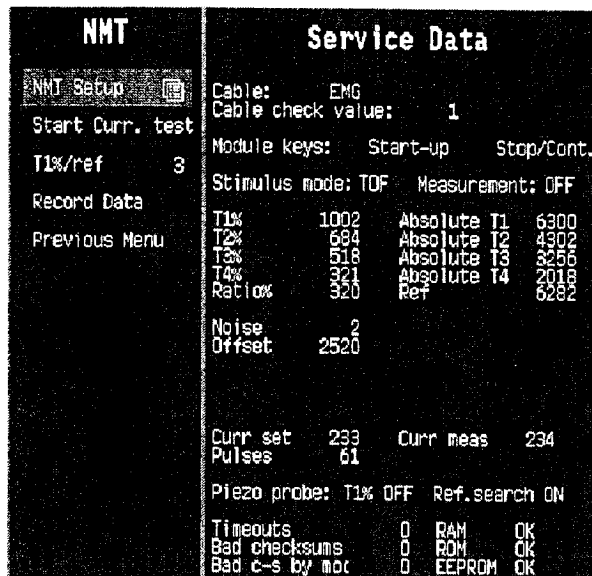

To access this menu from the Service View menu:

1. Select **Modules**.
2. Select **NMT**.

- Start Curr. test** A test that checks the difference between a given current and the measured current.
Connect a 3 kΩ resistance between the stimulus electrodes before starting the test. All currents that are checked will be displayed on the service data screen. After the current value, the test status is shown.
If the test is not passed, factory calibration is needed. Contact Datex-Ohmeda.
- T1%/ref** NMT MechanoSensor setting. Always use a setting of 3 for normal monitoring. Settings 1 and 2 are for research purposes only.
- Record Data** Prints the displayed service data and circuit board information (id., serial number, and software id.) to the optional Recorder.

NMT Service Data screen

- Cable** The type of cable being used.
- Cable check value** The bit amount. You can check the value for each cable using this chart:

EMG	-100 to +100
Cable OFF	> 1950
Piezo	900 to 1100
Regional block	600 to 800

- Module Keys** Not applicable to the Cardiocap/5.
- Stimulus mode** The stimulus mode selected in the NMT Setup menu.
- Measurement** Indicates status (ON/OFF).

T1%, etc.	The measured response. A value of 1000 corresponds to 100%. Each is a ratio of the Absolute T1, etc. to the Reference (Ref). As drugs are administered, the typical response for T1 lessens, then drops more rapidly for each successive measured response (T2%, T3%, then T4%).
Ratio%	The common label for TOF/DBS%.
Absolute T1, etc.	The voltage measured from the A/D converter. The area-under-the-curve of the response to stimulation as the muscle-relaxant anesthetic is being administered.
Ref	(Reference) The area-under-the-curve calculation from the response of the NMT stimulation before the administration of inhibiting anesthetics.
Noise	The interference just before the measurement. A typical value is < 10. Represents the measurement of the area-under-the-curve of the response when no stimulus is given, but the circuitry noise is picking up some response. The noise factor varies from sensor to sensor.
Offset	An average of the noise measurement; the voltage baseline. An offset of 2520 is 2520 mV, or 2.5 V. This is the measureable baseline voltage of the sensor and varies from sensor to sensor.
Curr set	The selected current, a value of 700 corresponds to 70 mA.
Curr meas	The measured current, a value of 700 corresponds to 70 mA.
Pulses	Pulses the module has produced.
Piezo probe T1%	Information related to MechanoSensor settings.
Ref. search	Information related to MechanoSensor settings.
Timeouts, Bad checksums, and Bad c-s by mod	are cumulative numbers that indicate the following: Timeouts --how many times the NMT unit did not respond to an inquiry from the monitor. Bad checksums --how many times communication from the NMT unit to the monitor failed. Bad c-s by mod --how many communication errors the NMT unit detected. Counting starts at power on and is reset to zero at power off. Nonzero values do not indicate a failure, but continuous counting (more than 50 per second) indicates a serial communication failure or that the NMT unit is not installed. Also, communication errors from other modules can cause these numbers to rise.
RAM	The state of RAM memory.
ROM	Indicates whether the checksum in the EPROM is in accordance with the value calculated by the software.
EEPROM	Indicates if the values stored in permanent memory are valid. The state is either OK, Fail or ? (module not installed or a communication error).

8.10.1 NMT Setup Menu

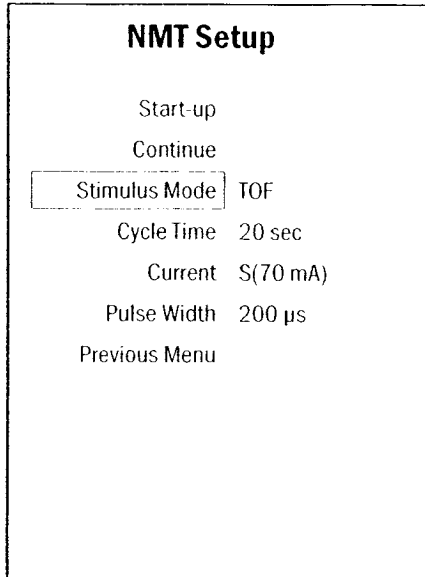

To access this menu from the Service View menu:

1. Select **Modules**.
2. Select **NMT**.
3. Select **NMT Setup**.

Start-up	Starts an NMT measurement.
Continue	Continues an NMT measurement.
Stimulus Mode	Selects the mode of stimulation: TOF (train of four), DBS (double burst stimulation), or ST (single twitch).
Cycle Time	<p>Sets the time intervals for the selected Stimulus Mode. For TOF and DBS, the selections are Manual, 10, 12, 15, or 20 seconds, and 1, 5, or 15 minutes. The ST cycle times are 1, 10, and 20 seconds.</p> <p>When the cycle time is less than one minute, the Count must be below the Count limit in two successive measurements before the Recovery Note is enabled. To give the note, the number of Counts must exceed or match the limit twice in one minute. The note disappears when two measurements are below the limit again.</p> <p>If the cycle time is one minute or more, or if the measurement is done manually, at least one Count must be below the chosen limit before the Recovery Note is enabled. To give the note, one Count must exceed or match the Count limit. The note disappears when one measurement is below the limit again.</p>
Current	Sets the stimulus current, which is either supramaximal (automatic start-up search) or manually selected from 10 mA through 70 mA at 5 mA intervals.
Pulse Width	Increases or decreases the effect of the stimulation. Selections are 100 µs, 200 µs, and 300 µs.

8.11 M-NSAT menu and data (N-XNSAT or N-XOSAT options)

M-NSAT	NSAT Data
Previous Menu	
	PR 60
	SpO ₂ % 9900
	NoProbe 0
	PulseSearch 0
	NoPulse 0
	CheckProbe 0
	MP-203 Error No
	QUART Error No
	I/O Error No
	Timeouts 0
	Bad checksums 0 ROM OK
	Bad c-s by mod 0

To enter this service menu from the Service View menu:

1. Select **Modules**.
2. Select **M-NSAT**.

PR	Pulse rate value [bpm] calculated from pleth.
SpO₂%	Oxygen saturation value multiplied by 100.
NoProbe	Not applicable to the Cardiocap/5.
PulseSearch	
NoPulse	
CheckProbe	
MP-203 Error	Yes if an error message is sent by the SpO ₂ board. NOTE: MP-203 Error is used to represent any version of the Datex-Ohmeda or Nellcor SpO ₂ board.
QUART Error	Yes if an error is detected in the QUART data communications device located in the SpO ₂ interface board.
I/O Error	Yes when a communication error occurs between the SpO ₂ board and the SpO ₂ interface board.
Timeouts, Bad checksums, and Bad c-s by mod	are cumulative numbers that indicate the following: Timeouts —how many times the unit did not respond to an inquiry from the monitor. Bad checksums —how many times communication from the SpO ₂ unit to the monitor failed. Bad c-s by mod —number of communication errors detected by the SpO ₂ unit. Counting starts at power on and is reset to zero at power off. Nonzero values do not indicate a failure, but continuous counting (> 50 per second) indicates a serial communication failure or that the SpO ₂ unit is not installed. Also, communication errors from other modules can cause these numbers to rise.
ROM	Indicates whether the checksum in the EPROM is in accordance with the checksum calculated by the software. The state is OK , Fail or ? (unit not installed or communication error).

8.12 More Modules menu

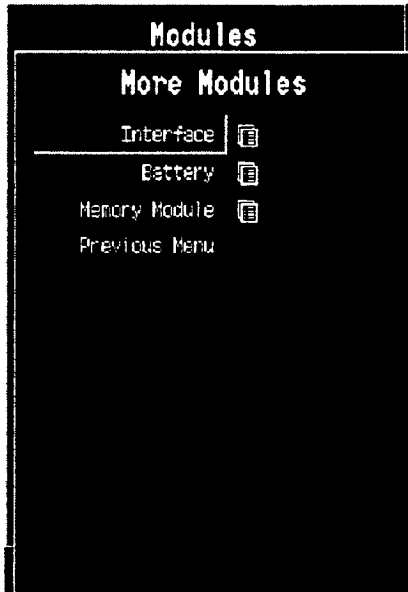

To enter this service menu from the Service View menu:

1. Select **Modules**.
2. Select **More Modules**.

NOTE: The **Interface** and **Battery** selections in the More Modules menu are not used in Cardiicap/5.

8.12.1 Memory Module menu and Module Status data

Memory Module	Module Status	
Module Status	Module present	YES
Communication	Module active	YES
Previous Menu	ROM	OK
	RAM	OK
	PCMCIA	OK
	EEPROM	OK
	SLOT1	SLOT2
	Card type	MENU DATA
	File system	ATA ATA
	Card size	5959 kB 5059 kB
	Card used	2916 kB 12 kB
	Card full	NO NO
	Card empty	NO NO
	Read error	NO NO
	Write error	NO NO

To enter this service menu from the Service View menu:

1. Select **Modules**.
2. Select **More Modules**.
3. Select **Memory Module**.

Module Status screen

NOTE: All values can be '-' to indicate "No data is available."

Module present	Indicates whether the module is firmly attached to the monitor (YES or NO).
Module active	Indicates whether module services are available (YES or NO).
ROM	Status of the memory module's ROM memory (OK or ERR).
RAM	Status of the memory module's RAM memory (OK or ERR).
PCMCIA	Status of the memory module's PCMCIA controller (OK or ERR).
EEPROM	Status of the memory module's EEPROM memory (OK or ERR).
SLOT1, SLOT2	The foremost slot and the rearmost slot, respectively.
Card type	The type of card (MENU or DATA). If duplicated card is inserted, type DUPL.
File system	The memory card file system (ATA is the only supported file system). If a non-ATA card is used, UNKNOWN is shown. If the card is poorly attached, LOOSE is shown.
Card size	The total amount of disk space in the card in kilobytes.
Card used	The total amount of used disk space in the card in kilobytes.
Card full	Indicates whether all disk space in the card is used (YES or NO).
Card empty	Indicates the lack of menu files in the MENU card or no files in the DATA card. Possible values are YES and NO.
Read error	Indicates whether reading from the card failed (YES or NO).
Write error	Indicates whether writing to the card failed (YES or NO).

8.12.2 Memory Module menu and Communication data

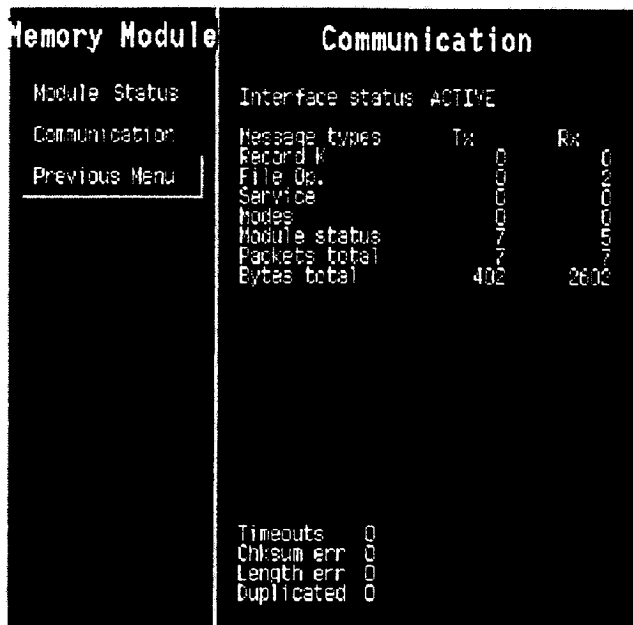

To enter this service menu from the Service View menu:

1. Select **Modules**.
2. Select **More Modules**.
3. Select **Memory Module**.
4. Select **Communication**.

Communication screen

Interface status

The status of the data link between the monitor and the memory module. If memory module is properly attached, the status should always be ACTIVE. If status blinks between ACTIVE and CLOSED, a communications error has occurred: remove module briefly, and insert it back into the monitor frame to check if the error disappears.

Message types The type of data packets sent (Tx) and received (Rx) since the last monitor start:

Record K—communication between the Monitor and Record Keeper.

File Op.—operations of Patient data.

Service—Memory Module operations.

Modes—User Mode operations.

Module status—number of sent/received data packets that relate to the memory module status.

Packets total—total number of data packets sent/received since last monitor start.

Bytes total—total number of data bytes sent/received since last monitor start.

Transmission errors since the last monitor start:

Timeouts—The number of time-outs that occurred in memory module data transmission.

Chksum err—The number of checksum errors in data packets from memory module.

Length err—The number of data packets with erroneous length from the memory module.

Duplicated—The number of duplicate data packets from the memory module.

8.13 Service Log menu

The service log contains information about the monitor errors and events that occurred since the last factory reset or service log reset. The service log is saved in the main CPU board's SRAM memory.

NOTE:

- **Cold start** is a start-up with a power-off time of more than 15 minutes. The trend memory is cleared and monitoring starts with the user default settings.
- **Warm start** is a start-up with a power-off time of less than 15 minutes. The trend information and possible temporary settings are still available.

Scroll Last Er Scrolls the error (event) information.

Scroll Counters Scrolls the error or event counters.

Record Log Prints the service log information on paper (with the recorder option, N-XREC).

Reset Log Clears the service log content (recommended after a performed maintenance).

Reset Run Time Resets the monitor's run-time counter. The counter is located in the main CPU board's SRAM and basically counts the amount of time the monitor has been on since leaving the factory.

Error History

```

Service Log
-----
Event History
Alarm History
Scroll Last Er
Scroll Counters
Record Log
Reset Log
Previous Menu

Error History
-----
Last errors:
Fast cold start (off 15 s < 20 s)
1999-Oct-20 15:06:13
GSP watch-dog time-out
1999-Oct-20 15:05:57
Fast cold start (off 15 s < 20 s)
1999-Oct-20 15:05:37
GSP watch-dog time-out
1999-Oct-20 15:05:20
Fast cold start (off 15 s < 20 s)
1999-Oct-20 15:05:01
-More-

Error counters:
Fast cold start (off 15 s < 20 s)
Count 13 last 1999-Oct-20 15:06:13
GSP watch-dog time-out
Count 5 last 1999-Oct-20 15:05:57

Last log reset: 1997-Dec-22 13:56:03

```

To enter this service menu from the Service View menu, select **Service Log**.

- Last errors** Shows the last monitor errors and the time of their occurrence.
- Error counters** Contains counters for each different (detected) monitor error. The time of occurrence of the last error is shown beside each counter.
- Fast cold start** Gives the number of erroneous cold starts when power was off < 20 seconds. The cause can be a failing lead-acid battery or a software problem that was solved by the hardware watchdog circuitry.
- Last log reset** Shows the date and the time of last service log reset.

Event History



To enter this service menu from the Service View menu:

1. Select **Service Log**.
2. Select **Event History**.

- Running hours** Shows how many hours the monitor has been on **since** the date and the time of the last run-time reset.
- Last events** Shows the last events and the time of their occurrence.
- Event counters** Contains counters for each different (detected) event. The time the last event occurred is shown beside each counter.
- Last log reset** Shows the date and the time of the last service log reset.

Alarm History

Shows the monitor alarm log. The alarm log is reset if the monitor is in standby for more than 15 minutes.



To enter this service menu from the Service View menu:

1. Select **Service Log**.
2. Select **Event History**.
3. Select **Alarm History**.

Chapter 9. Spare parts

9.1 General service parts	9-1
9.1.1 Service kits and tools.....	9-1
9.1.2 Software upgrades	9-1
9.2 F-MX (hemodynamic) and F-MXG (hemodynamic with gas)	9-2
9.2.1 Mechanical spare parts.....	9-2
Push buttons	9-2
9.2.2 Electronic spare parts.....	9-4
9.2.3 Connector boards and PVX unit	9-8
9.2.4 Interconnect cables	9-9
9.3 Parameter unit (NESTPR) and invasive pressures option (N-XP)	9-10
9.4 Airway gas options (N-XC, N-XCO, N-XCAiO)	9-11
9.4.1 Service kits.....	9-11
9.4.2 Airway gas spare parts.....	9-12
9.5 Recorder option (N-XREC)	9-13
9.6 NMT and pulse oximetry options.....	9-14
9.6.1 Service kits.....	9-14
9.6.2 NMT option (N-XNMT).....	9-14
9.6.3 Pulse oximetry options (N-XOSAT and N-XNSAT)	9-15

9. SPARE PARTS

Use the **Order Number** when ordering parts. Item numbers are used only to identify parts shown in the illustrations.

NOTE: Remanufactured or exchange parts may be available for some measurement units or boards. Request information when you order the part.

9.1 General service parts

9.1.1 Service kits and tools

Item/Description	Order Number
Service Kit, Hardware <i>Includes:</i> Connector lock screw, M3 (5) EMI seal (5) Screw, hexagon M4x16 (5) Screw, pozidrive M3x6 (25), M3x10 (5), M3x12 (5), M4x6 (5), M4x20 (5) Screw, pozidrive plastite M2.5x10 (5), M3x8 (15) Screw, pozidrive zinc 2x5 mm (5) Sleeve, 6 x 2.5 mm (for display unit) (2) Spacer, nylon (for Inverter board) (5) Standoff bushing (5) Washer, ext-lk M3 SST (5) Washer, securing, AS/3 CM (5) Washer, fiber, 0.125 ID x 0.312 OD (5)	6050-0005-751
Service Kit, PCA Drawings (Drawings, schematics, and components)	6050-0005-946
Troubleshooting extension cable	884298
Temperature calibration test plugs (25 °C and 45 °C)	884515

9.1.2 Software upgrades

Item/Description	Order Number
U-XANE Software upgrade, English, Dutch, French, German	6050-0005-724
U-XANE Software upgrade, English, Italian, Portuguese, Spanish	6050-0005-725
U-XANE Software upgrade, Danish, English, Finnish, Norwegian, Swedish	6050-0005-726
U-XANE Software upgrade, English, Polish	6050-0006-859
U-XCCA Software upgrade, Dutch, English, French, German	6050-0005-727
U-XCCA Software upgrade, English, Italian, Portuguese, Spanish	6050-0005-728
U-XCCA Software upgrade, Danish, English, Finnish, Norwegian, Swedish	6050-0005-729
U-XCCA Software upgrade, English, Polish	6050-0006-857
U-XNET Network software upgrade	6050-0005-733
U-XDNET Data card and Network software upgrade, English	6050-0005-730
U-XDNET Data card and Network software upgrade, French	6050-0005-731
U-XDNET Data card and Network software upgrade, German	6050-0005-732

9.2 F-MX (hemodynamic) and F-MXG (hemodynamic with gas)

9.2.1 Mechanical spare parts

Item	Description	Order Number
1	Recorder hole cover plate (plastic)	895711
2	Recorder hole cover plate (metallic)	895712
3	Front cover	6050-0005-758
4	Rubber pad	895174
5	D-fend housing unit, complete	894737
6	D-fend body connector	875052
	O-ring for D-fend body connector	65312
	Lock ring for D-fend body connector	63813
7	Shield for display cable	6050-0005-865
8	Back cover unit	6050-0005-757
9	Rear foot, base (included in Item 8)	Order Item 8
10	Rubber pad	65141
11	Label set <i>Includes</i> equipotentiality sticker (shown), battery (not shown), and patent sticker (not shown)	6050-0005-677
12	Dust filter	896113
13	Back mounting	896199
14	Rear panel label, F-MX	896927
	Rear panel label, F-MXG	896928
Not shown	Cover for memory card slots	6050-0005-866

Push buttons

Button (Silence Alarms)	Order Number
Danish, Silence Alarms	896958
Dutch, Silence Alarms	896839
English, Silence Alarms	896836
Finnish, Silence Alarms	896843
French, Silence Alarms	896838
German, Silence Alarms	896837
Italian, Silence Alarms	896841
Norwegian, Silence Alarms	896845
Polish, Silence Alarms	6050-0006-503
Portuguese, Silence Alarms	896842
Spanish, Silence Alarms	896840
Swedish, Silence Alarms	896844

Button (Normal Screen)	Order Number
Danish, Normal Screen	896877
Dutch, Normal Screen	896870
English, Normal Screen	896867
Finnish, Normal Screen	896874
French, Normal Screen	896869
German, Normal Screen	896868
Italian, Normal Screen	896872
Norwegian, Normal Screen	896876
Polish, Normal Screen	6050-0006-498
Portuguese, Normal Screen	896873
Spanish, Normal Screen	896871
Swedish, Normal Screen	896875

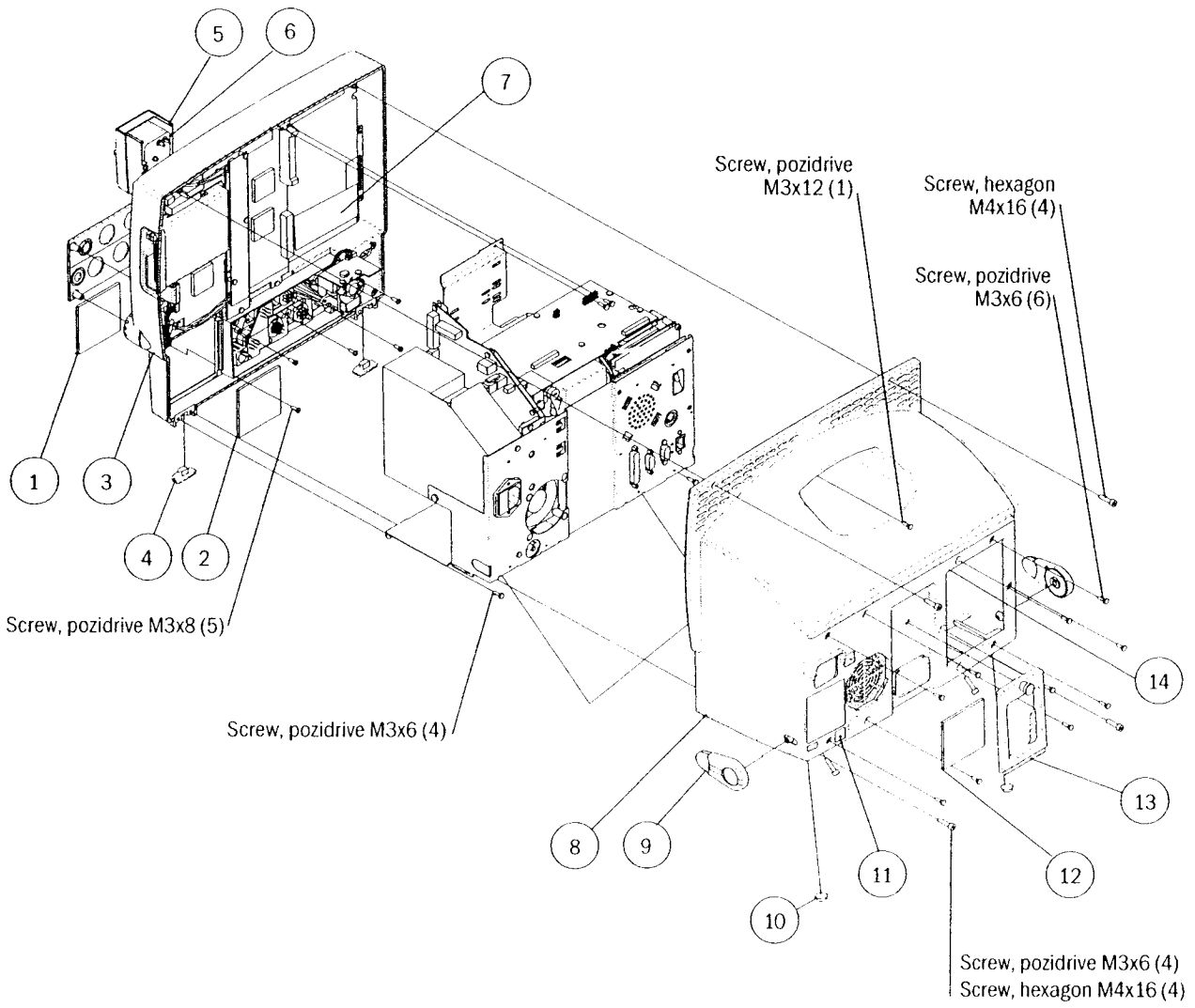

9.2.2 Electronic spare parts

Item	Description	Order Number
15	Potential equalization connector	6027-0000-018
16	Fuse T2AH	511200
17	AC/DC unit	6050-0005-749
18	Mother board	6050-0005-753
19	DC/DC board (ID 895830)	897498
20	NIBP cuff hose connector	64654
21	NIBP adapter, F-MX	895173
	NIBP adapter, F-MXG	895172
22	Parameter unit, NESTPR (ID 895828)	898957
23	Battery 3Ah 12V (ID 17013)	897507
24	Airway gas unit, N-XC (ID 896227)	898954
	Airway gas unit, N-XCO (ID 896228)	898955
	Airway gas unit, N-XCAiO (ID 896226)	898956
25	Fan unit	895823
26	I/O board (ID 895821)	897503
27	Net board	895820
28	Loudspeaker unit (ID 895879)	897504

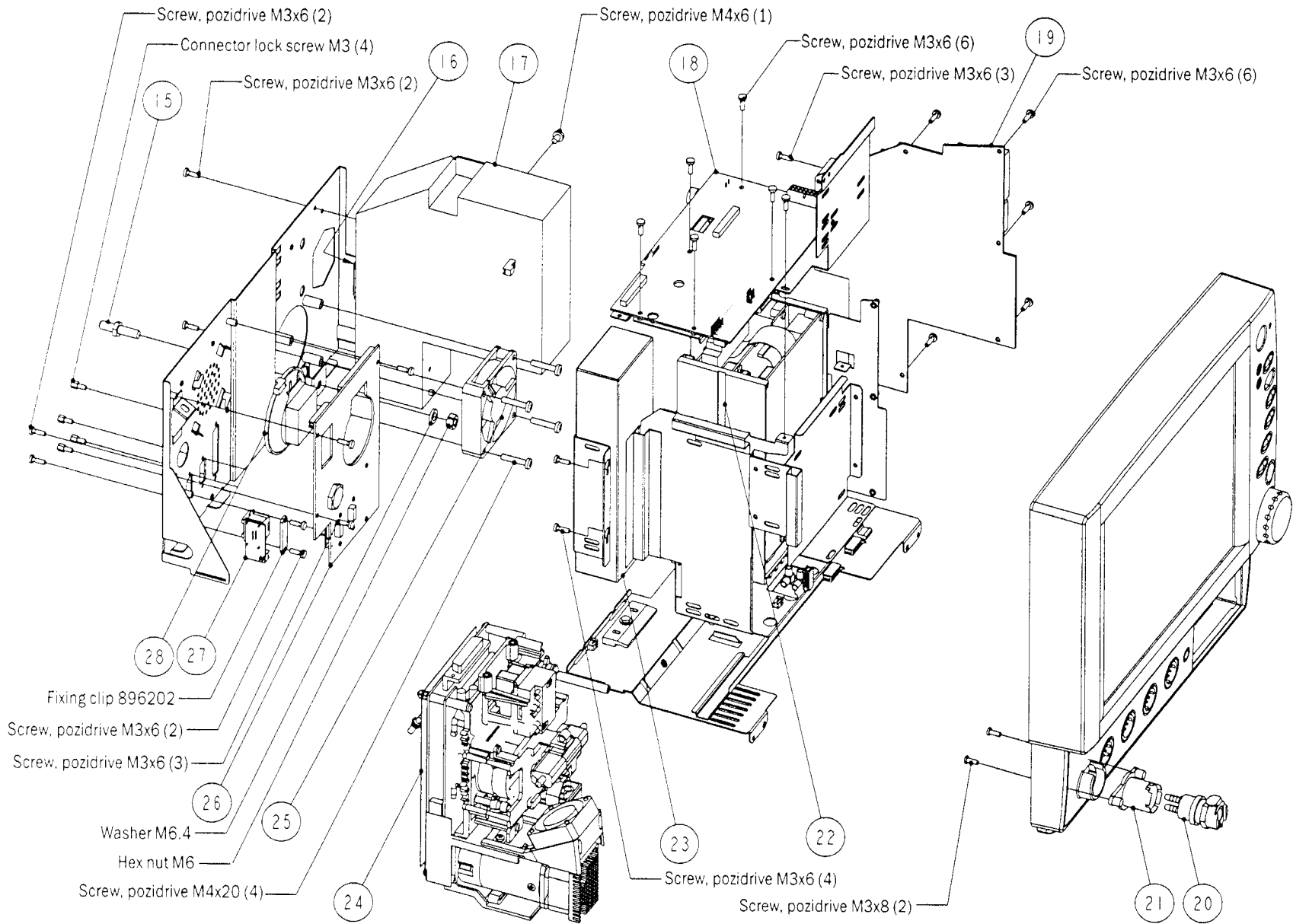

Electronic spare parts (continued)

Item	Description	Order Number
29	EMI Seal	Order Hardware Kit 6050-0005-751
30	LCD display shield (included in item 31)	Order Item 31
31	LCD display unit, complete with display shield (28) (ID 894745)	897500
32	Backlight for LCD display (includes 2 bulbs)	572791
33	Service Kit, Display adapter board and mounting foam	6050-0006-020
34	Inverter board	6050-0005-752
35	Backlight board (ID 896222)	897502
36	Lithium battery for SRAM on CPU board (ID 197230)	897506
37	<p>CPU board (ID 895196)</p> <p>NOTE: The appropriate software service kit(s) are required when replacing the CPU board (and may be required when replacing the battery, depending on the monitor software level):</p> <ol style="list-style-type: none"> 1. Service Kit, Cardiocap/5 Monitor Software: Dutch English French German 2. Service Kit, Cardiocap/5 Monitor Software: English Italian Portuguese Spanish 3. Service Kit, Cardiocap/5 Monitor Software: Danish English Finnish Norwegian Swedish 4. Service Kit, Cardiocap/5 Monitor Software: English Polish 5. Service Kit, Cardiocap/5 N-XNET Software (order if N-XNET is installed) 6. Service Kit, Cardiocap/5 N-XDNET Software (order if N-XDNET is installed) 	<p>897499</p> <p>XANE: 6050-0005-821 or XCCA: 6050-0005-819</p> <p>XANE: 6050-0005-992 or XCCA: 6050-0005-993</p> <p>XANE: 6050-0005-994 or XCCA: 6050-0005-995</p> <p>XANE: 6050-0006-860 or XCCA: 6050-0006-858</p> <p>6050-0005-820</p> <p>6050-0005-822</p>
38	ComWheel switch, rotary	6050-0005-748
39	Keyboard	6050-0005-756
40	ComWheel knob	896291

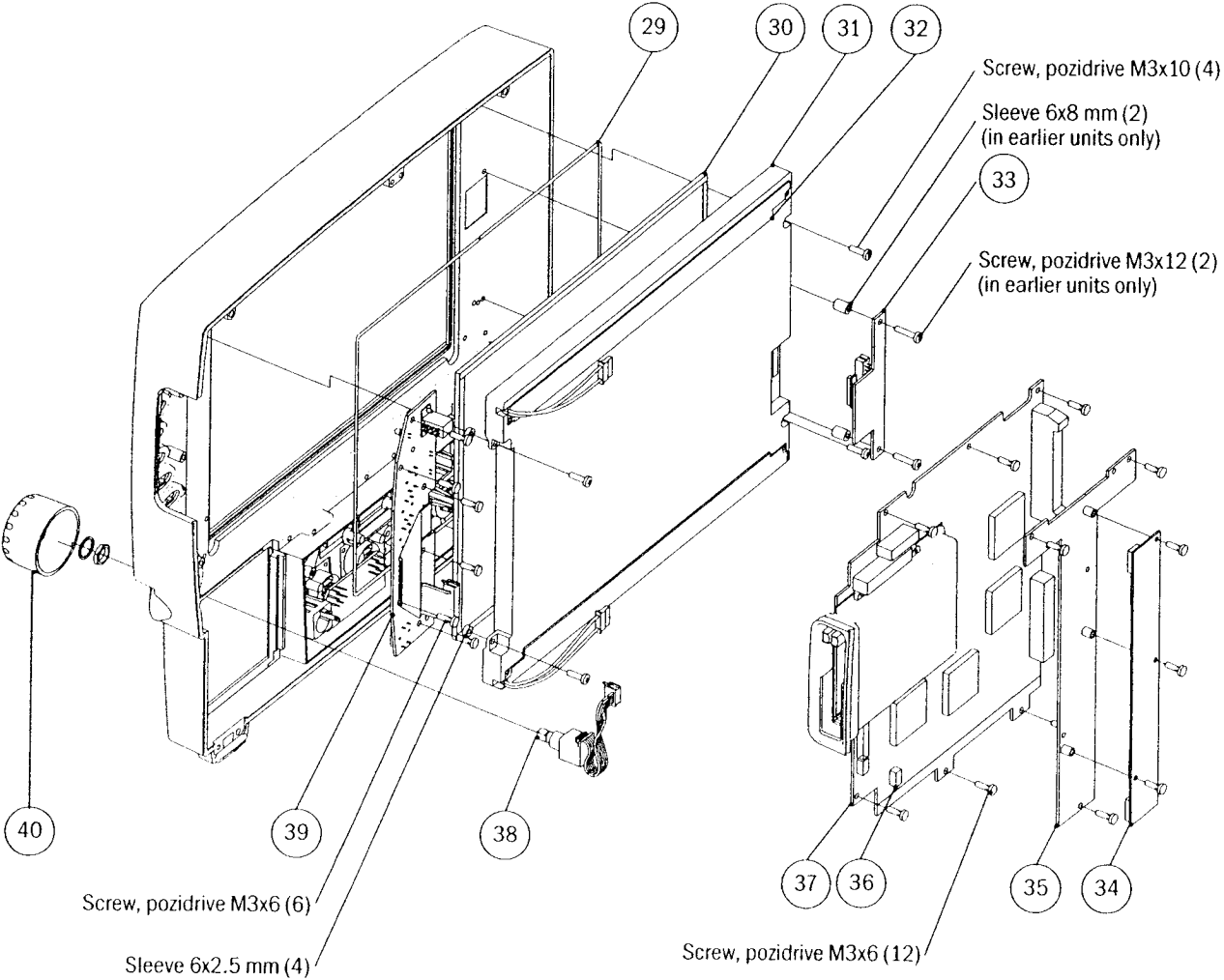

9.2.3 Connector boards and PVX unit

Item	Description	Order Number
41	Temperature connector board/cable assembly	895826
42	PVX unit for spirometry (ID 895771)	898958
43	Invasive blood pressure connector board/cable assembly, F-MX	895871
	Invasive blood pressure connector board/cable assembly, F-MXG	895163
44	Service Kit, SpO ₂ connector board/cable assembly, standard	895824
	Service Kit, SpO ₂ connector board/cable assembly, N-XNSAT option	6050-0006-010
	Service Kit, SpO ₂ connector board/cable assembly, N-XOSAT option	6050-0006-014
45	ECG connector board/cable assembly	895160
46	Service Kit, NMT connector board/cable assembly	6050-0006-011

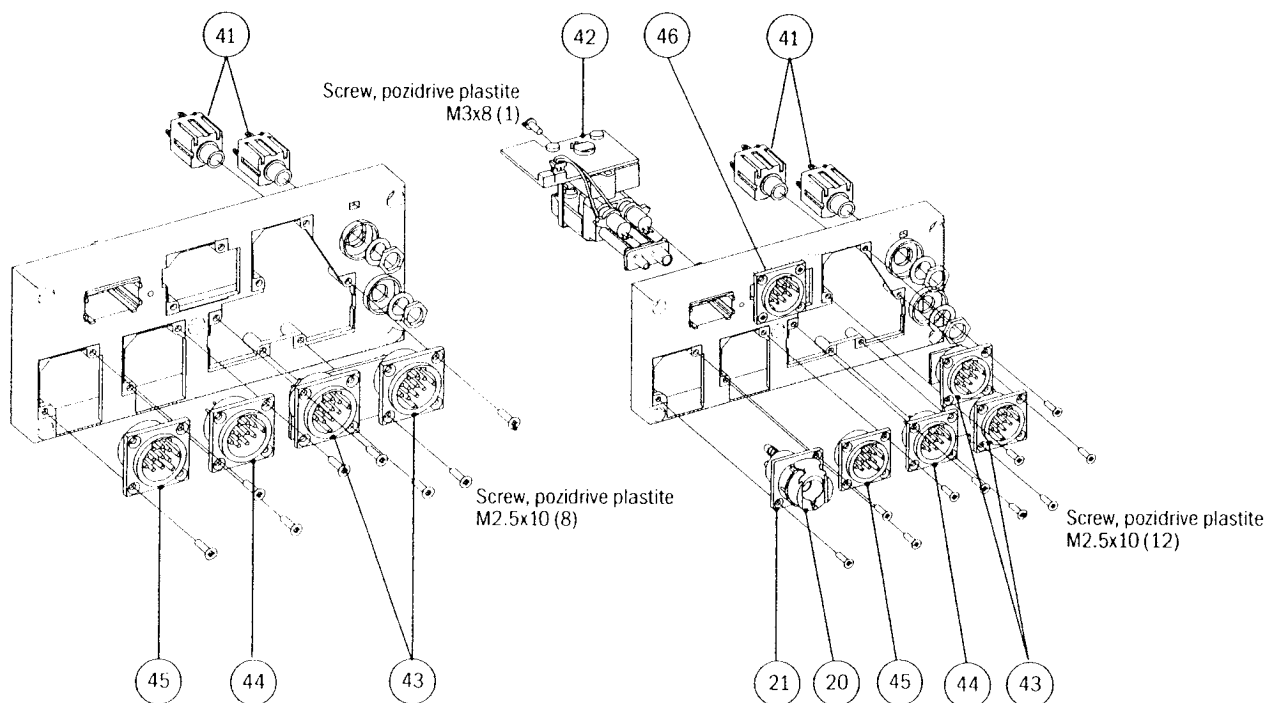

9.2.4 Interconnect cables

Item	Description	Order Number
50	AC/DC - DC/DC	904810
51	DC/DC - CPU (data)	896221
52	DC/DC - CPU (power)	895876
53	DC/DC - Mother board	895877
54	CPU - Mother board	896214
55	CPU - Backlight board	896218
56	CPU - NET board	896220
57	CAiO - PVX (valves)	896022
58	CAiO - PVX (data)	896023
59	Battery - Mother board	896477
60	Backlight board - Inverter board	896217
61	Interface board - Mother board NMT board - Mother board	6050-0005-947
62	NSAT SpO ₂ board - SpO ₂ Interface board OSAT SpO ₂ board - SpO ₂ Interface board	8001925

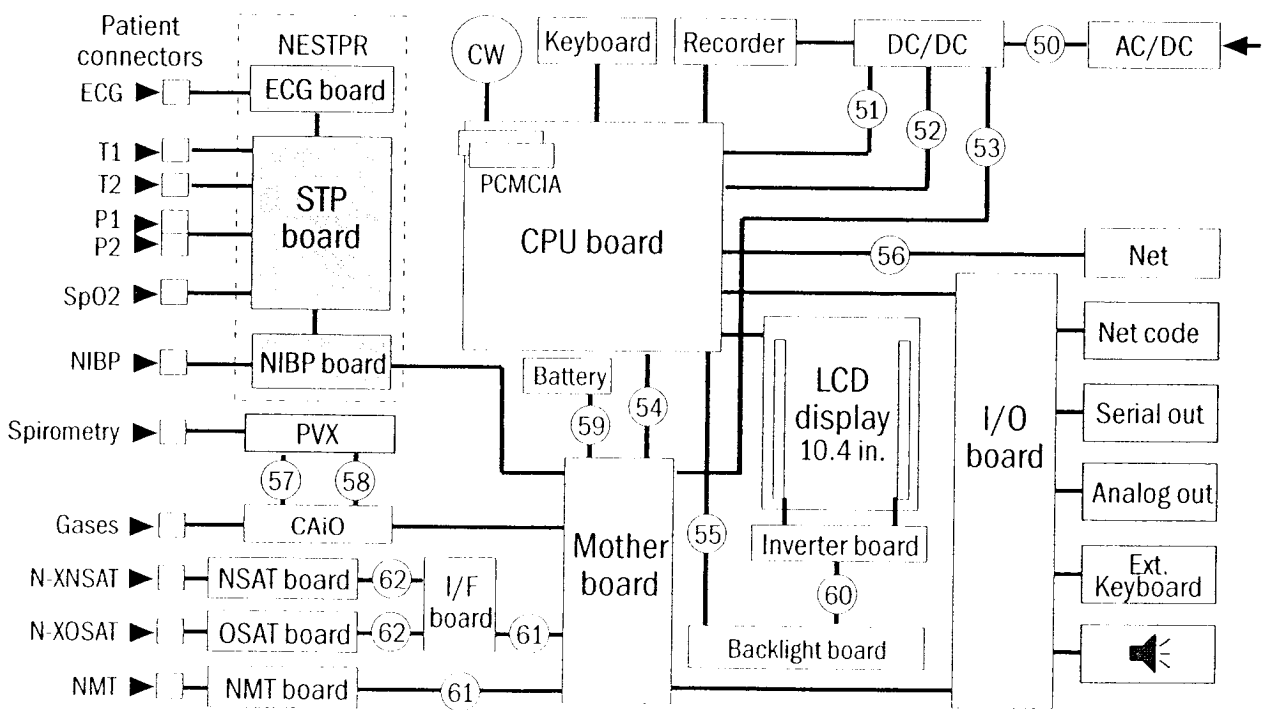

9.3 Parameter unit (NESTPR) and invasive pressures option (N-XP)

Item	Description	Order Number
70	ECG/Resp board	889988
71	Left side plate	895857
72	Star shaft	895855
73	Star plate	895856
74	ECG cable	895818
75	SpO2 cable	895815
76	Invasive pressure cable	895816
77	Temperature cable with T1 (black wires) and T2 (yellow wires) connectors	895817
78	Ribbon cable	890874
79	Strain relief	895958
80	STP board	8002574
81	Right side plate	895858
82	NIBP unit	888272
83	Damping chamber	888240
Not shown	NIBP filter	57142

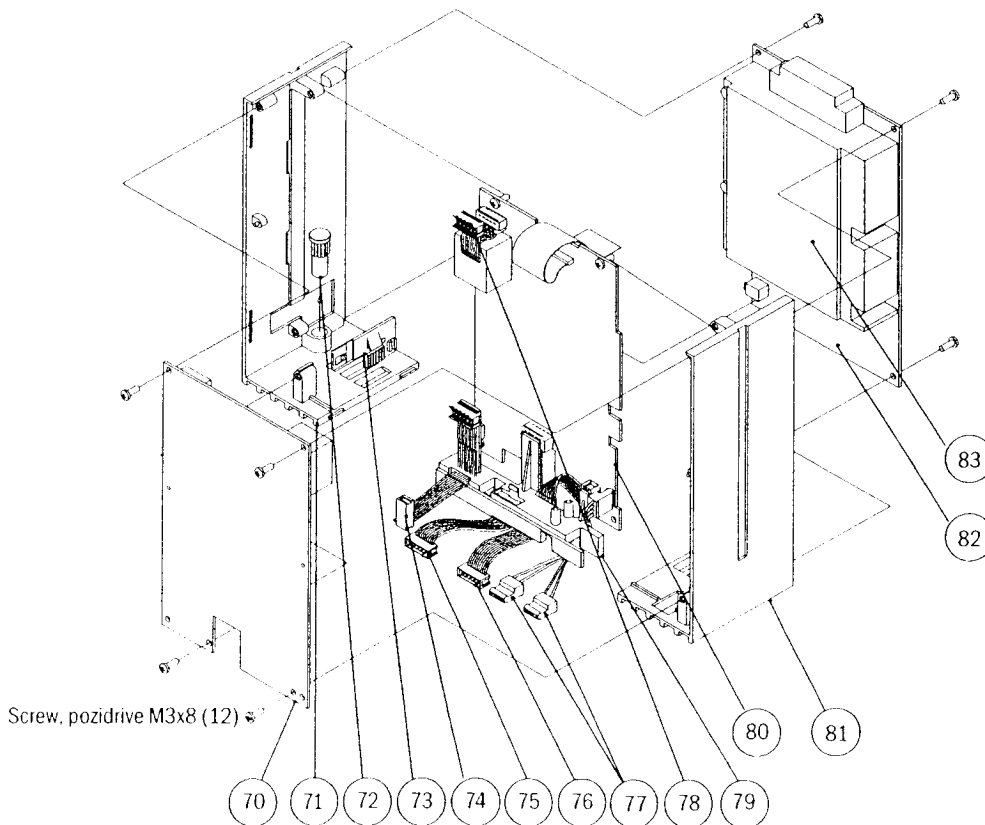

9.4 Airway gas options (N-XC, N-XCO, N-XCAiO)

9.4.1 Service kits

Item/Description	Order Number
Service Kit, Planned Maintenance, Anesthesia <i>Includes:</i> Nafion tubing Zero filter Occlusion filter OM reference filter Fan filter D-fend O-ring PM (Planned Maintenance) sticker Installation guide	8001760
Service Kit, Planned Maintenance, Critical Care <i>Includes:</i> Nafion tubing Zero filter Occlusion filter OM reference filter Fan filter D-fend O-ring PM (Planned Maintenance) sticker Installation guide	8001761
Service Kit, Gas Unit Maintenance (for securing bench) <i>Includes:</i> Foam pad Hook/loop strap Tubing sleeves	6050-0005-893

9.4.2 Airway gas spare parts

Item	Description	Order Number
85	Nafion tube 300 mm	733382
86	Fan unit	896529
87	Occlusion/zero filter (2 pcs/package)	886136
88	Luer connector, male (sampling gas outlet)	895716
89	Sleeve	891035
90	Gas unit CPU board	884313
91	Cable tie 90mm	64001
92	OM reference filter (3)	86901
93	Cable tie 150mm	64000
94	Pump unit	57313
95	Mounting plate	895190
96	Wall plate	895690

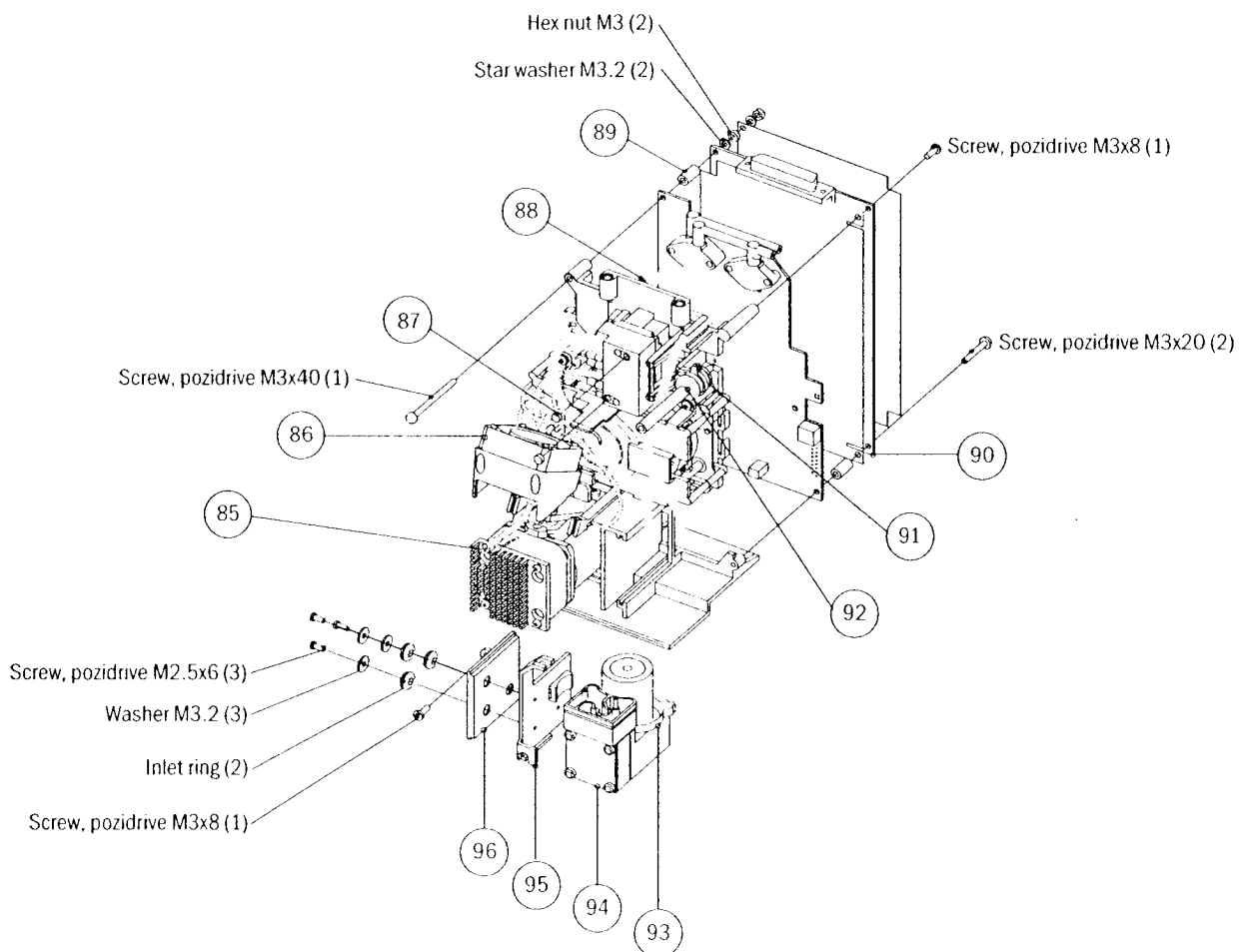

9.5 Recorder option (N-XREC)

Item	Description	Order Number
98	Paper holder for recorder	Not available
99	Service Kit, Recorder unit, 1 button	6050-0005-755
	Service Kit, Recorder unit, 2 button (for monitors with software version 3.0 or later)	6050-0006-009
100	Recorder board (including recorder box) for 1-button or 2-button recorder	6050-0005-754
101	Recorder board (does not include recorder box) for 1-button or 2-button recorder	895192

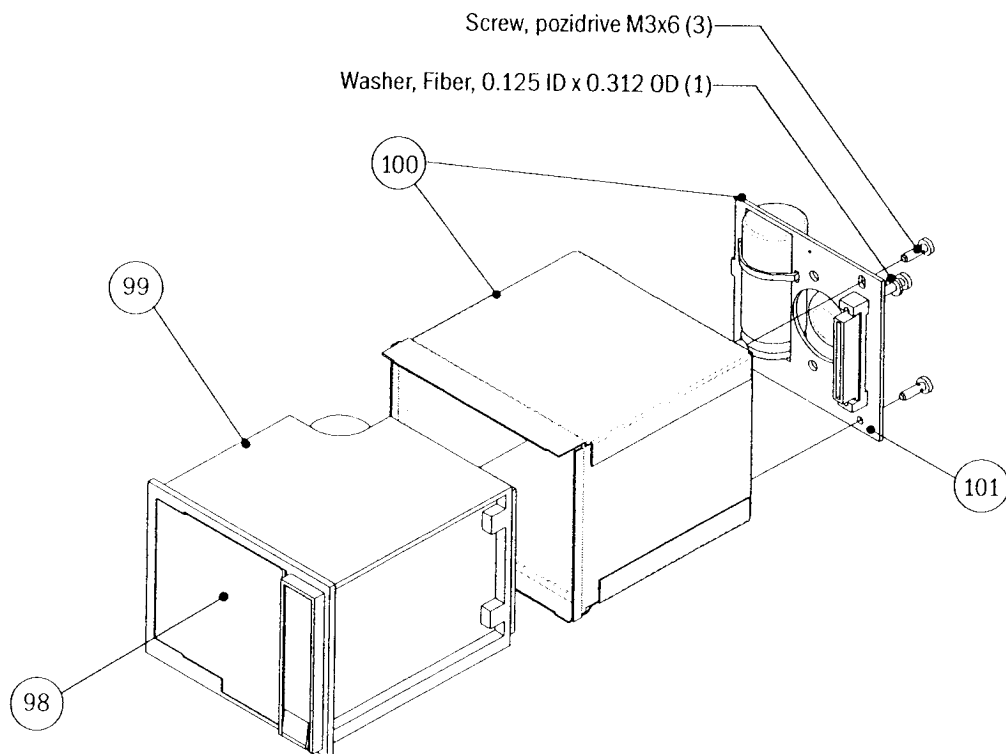

9.6 NMT and pulse oximetry options

9.6.1 Service kits

Item/Description	Order Number
Service Kit, Options Enclosure <i>Includes:</i> EMC shield Options cover	6050-0006-013

9.6.2 NMT option (N-XNMT)

Item	Description	Order Number
105	EMC shield	Order Options Enclosure Kit: 6050-0006-013
106	NMT board	887487
107	EMC cover for NMT microprocessor	886320
108	Options cover	Order Options Enclosure Kit: 6050-0006-013

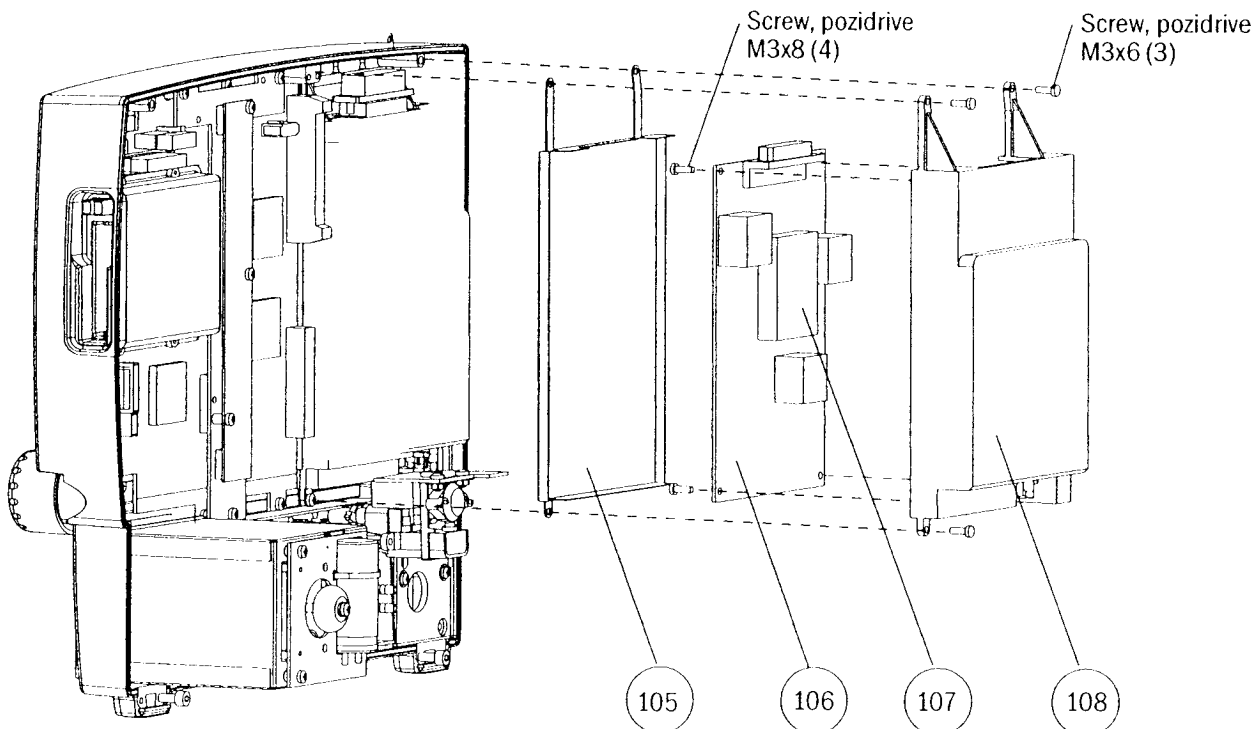

9.6.3 Pulse oximetry options (N-XOSAT and N-XNSAT)

Item	Description	Order Number
110	SpO ₂ Interface board	6050-0006-012
111	Service Kit, Nellcor MP404 SpO ₂ measurement board, N-XNSAT	6002-0000-164
112	Service Kit, SpO ₂ measurement board, N-XOSAT	6050-0005-648
113	EMC cover for NSAT or OSAT board	884701

