

System SIRECUST SIRECUST 1280/1281 Bedside Monitors Service Manual

EP

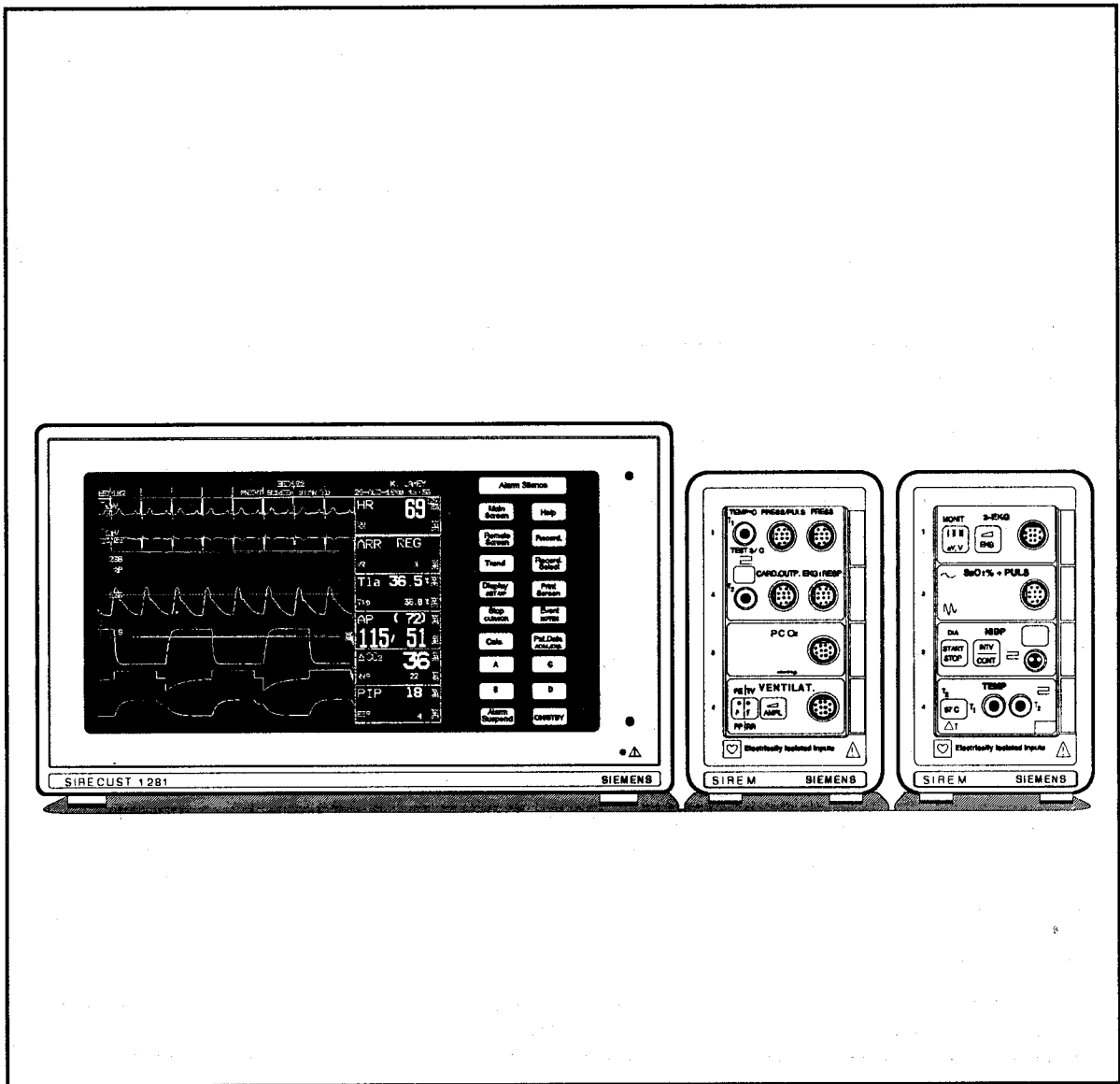

Copyright © SIEMENS AG 1990

All rights reserved.

Reproduction in any manner, in whole or in part, in English or in other languages, except for brief excerpts in reviews or scientific papers, is prohibited without prior written permission of SIEMENS AG.

Copyright © SIEMENS AG 1990

Alle Rechte vorbehalten.

Nachdruck, auch auszugsweise oder in Übersetzung, ist ohne Genehmigung der SIEMENS AG verboten.

Copyright © SIEMENS AG 1990

Droits de reproduction réservés.

Ce document, à l'exception de quelques passages pour des revues ou articles scientifiques, ne peut être reproduit, traduit, en tout ou partie, que sur autorisation écrite de SIEMENS AG.

Copyright © SIEMENS AG 1990

Es propiedad © SIEMENS AG, 1990

Todos los derechos reservados.

Se prohíbe la reproducción en parte o completa en español o en cualquier otra lengua, con excepción de breves pasajes para reseñar o para documentos científicos, sin previo permiso de Siemens AG.

**System SIRECUST
1280/1281 Bedside Monitor
Service Manual**

SIRECUST 1280/1281 BEDSIDE MONITOR - SERVICE MANUAL

TABLE OF CONTENTS

Chapter 1. INTRODUCTION

Chapter 1 contains general information about the monitors and about the manual.

Chapter 2. MONITOR OPERATIONS

Chapter 2 contains brief descriptions of monitor operations, both as a standalone system and as a sub-system of a SIRENET network.

Chapter 3. INTERNAL MONITOR FUNCTIONS

Chapter 3 details operation of sub-systems within the monitor from a functional block diagram perspective.

Chapter 4. REMOVING/INSTALLING SYSTEM COMPONENTS

Chapter 4 lists step-by-step procedures for disassembling and reassembling the monitor, and for removing and installing replaceable components and sub-assemblies.

Chapter 5. FUNCTIONAL VERIFICATION

Chapter 5 outlines procedures for verifying proper operation of monitors, in accordance with SIEMENS specifications, and references appropriate service procedures in the event of a possible malfunction.

Chapter 6. TROUBLESHOOTING

Chapter 6 provides a logical procedure for isolating and identifying causes of possible malfunctions, and refers service personnel to appropriate Sections in the Manual for procedures to correct the malfunction.

Chapter 7. CALIBRATION/ADJUSTMENT

Chapter 7 describes recommended procedures for calibrating and adjusting the monitors circuits to maintain optimum performance of the monitor in accordance with SIEMENS specifications.

TABLE OF CONTENTS (Continued)

Appendix A. REPLACEMENT PARTS

Appendix A is a listing of replacement parts, and references assembly drawings to indicate positioning of the parts within the monitor.

Appendix B. WIRING/SCHEMATIC DIAGRAMS

Appendix B consists of an overall monitor wiring diagram and a set of schematic diagrams for the printed circuit boards contained within the monitor.

Appendix C. PC BOARD JUMPER SETTINGS

Appendix C consists of a set of drawings which show the positioning of jumpers on the printed circuit boards.

Appendix D. GLOSSARY OF SIGNALS

Appendix D is a listing of the signals found on each of the printed circuits within the monitor.

Appendix E. SUPPLEMENTAL INFORMATION

Appendix E contains descriptions of buildable test equipment and a description of the Self-test ERROR Codes and Messages provided by the monitor. It is also a place within the Manual for retaining supplemental information that is distributed to the field from time to time.

Appendix F. FUNCTIONAL VERIFICATION/PERFORMANCE CHECKLISTS

Appendix F contains forms for recording results of periodic maintenance and functional verification.

CHAPTER 1

INTRODUCTION

TABLE OF CONTENTS

1.1.	Service Manual Overview	1
1.1.1.	Structure of the Manual	1
1.2.	Safety Summary	1
1.3.	SIRECUST 1280/1281 Monitors	2
1.3.1.	General Overview	2
1.3.2.	Alarm Handling	2
1.3.3.	Monitor Control	2
1.3.4.	Monochrome vs Color Displays	2
1.3.5.	The SIRENET Network	3
1.3.6.	Standalone Operation	3
1.4.	Parameter Cartridges	3
1.5.	Technical Data	3
1.6.	Maintenance Recommendations	4
1.6.1.	Cleaning and Disinfecting	4
1.6.2.	Optimizing Monitor Performance	4

LIST OF FIGURES

Figure 1-1:	Technical Data	3
Figure 1-1:	Technical Data (Continued)	4

1. INTRODUCTION

1.1. Service Manual Overview

This Manual contains information to enable qualified service personnel to service SIRECUST 1280/1281 monitors at the replaceable module level. In light of the state-of-the-art technology used in SIEMENS equipment, proprietary nature of the software, and specialized equipment required in the replacement of some individual components, SIEMENS recommends troubleshooting and repair only to the board or replaceable part level. Replaceable parts are items that can be replaced with minimal or no desoldering of circuit components. Replacement of components other than those listed in Appendix A should be performed at SIEMENS service depots.

1.1.1. Structure of the Manual

The Manual has been structured to facilitate rapid and effective servicing of SIRECUST 1280/1281 monitors.

Chapter 1. Introduction: provides general information about the monitors and about the manual.

Chapter 2. Monitor Operations: contains brief descriptions of monitor operations, both as a standalone system and a sub-system of a SIRENET network.

Chapter 3. Internal Monitor Functions: details operation of sub-systems within the monitor from a functional block diagram perspective.

Chapter 4. Removing/Installing System Components: lists step-by-step procedures for disassembling and reassembling the monitor, and for removing and installing replaceable parts and sub-systems.

Chapter 5. Functional Verification: outlines procedures for verifying proper operation of monitors, in accordance with SIEMENS specifications, and references

appropriate service procedures in the event of a possible malfunction.

Chapter 6. Troubleshooting: provides a logical procedure for isolating and identifying causes of possible malfunctions, and refers service personnel to appropriate Sections in the Manual for procedures to correct the malfunction

Chapter 7. Calibration/Adjustment: describes recommended procedures for maintaining optimum performance of the monitor.

Appendix A. Replacement Parts List

Appendix B. Wiring/Schematic Diagrams

Appendix C. PC Board Jumper Settings

Appendix D. Glossary of Signals

Appendix E. Supplemental Information

Appendix F. Functional Verification/Performance Checklists

1.2. Safety Summary

CAUTION statements identify conditions or practices that can result in damage to equipment or other property.

CAUTION: *Printed circuit boards in this monitor contain components which are easily damaged by static-electricity. Open the monitor only in a static-protected environment. Observe proper servicing procedures to prevent damage to the equipment resulting from static discharge.*

WARNING statements identify conditions or practices that can result in personal injury.

WARNING: *Do not operate this product in the presence of flammable gasses or liquids. If this device is used where flammable anesthetics, skin cleansers, or disinfectants are employed, the possibility of an explosion cannot be excluded. This*

product must be operated only in strict conformance with local fire prevention regulations.

1.3. SIRECUST 1280/1281 Monitors

1.3.1. General Overview

SIRECUST 1280 and 1281 units are eight-channel bedside patient monitors having 12" screens that incorporate two different display techniques for presentation of waveforms and alphanumeric. An X-Y-Z display function draws waveforms as continuous lines, while a conventional raster mode produces letters, symbols, and graphics. Through the use of individual cartridges designed to convert human physiological vital signs into electrical signals, the monitors acquire, process, display, store and transmit a variety of waveforms, measured values and derived patient parameters. Up to eight physiological waveforms and twenty-one calculated parameters can be displayed simultaneously.

1.3.2. Alarm Handling

The monitor provides audible and visual alarm indications. An alarm condition exists whenever a parameter value is outside a defined range, and for specific technical situations such as loss of electrode contact with a patient or the occurrence of artifact in a monitored signal. The three audible alarm levels are:

Advisory	- low frequency tone
Serious	- high frequency tone
Life-threatening	- distinctive two tone

In a multi-bedside environment, the variable alarm tone makes it possible to differentiate among the different alarm grades. Two different keys are available for handling audible alarms: one key silences an individual alarm and another suspends all alarms.

1.3.3. Monitor Control

A state-of-the-art TouchScreen User Interface with menu-driven function selection controls the many functions of the monitor. At the bedside, operating commands are entered through the TouchScreen in the form of specific KEY sequences.

The TouchScreen contains both fixed keys and program keys. Fixed keys are defined for essential functions that must always be quickly accessible. Specific program keys appear on the screen depending on the function involved. All functions are menu driven. Monitor operations can also be controlled from a central station if the monitor is connected into a SIRENET network.

Refer to the System SIRECUST 1280/1281 Bedside Patient Vital Signs Monitor Operating Instructions for the installed software version, Order No. A91004-M3331-L079-XX-7600, for a detailed description of monitor operations and key sequences.

1.3.4. Monochrome vs Color Displays

SIRECUST 1280 and 1281 monitors differ only in the color capability for displaying waveforms. The "1" in 1281 designates a multi-color display capability. A liquid crystal shutter in front of the monochrome CRT, enables SIRECUST 1281 monitors to display waveforms in four (4) colors -- red, green, yellow, and orange. SIRECUST 1280 monitors display waveforms only in yellow-green.

1.3.5. The SIRENET Network

As part of a centralized patient monitoring system, SIRECUST 1280/1281 bedside units can be connected to a central station and SIREDOC recorders via a high speed communication link, the SIRENET network. Within the SIRENET network, each device is interconnected to all other devices in the network.

1.3.6. Standalone Operation

Beginning with software version VE0, the bedside monitor can directly initiate SIREDOC recordings without being connected into the SIRENET and a central station. Up to two SIREDOC recorders (S60 and/or S220) can be connected to a standalone bedside monitor.

1.4. Parameter Cartridges

Monitors have been designed to support up to two remote cartridge units, called SIREMs, each of which can accommodate up to four (4) physiological parameter cartridges. Patient data are digitized inside the cartridges, and then transmitted to the SIREM via infrared signals through "windows" in the back plates of the

cartridges. The small compact size of a SIREM allows it to be placed close to the patient, while the monitor is mounted elsewhere at a more convenient location for easy accessibility by the nurse or other staff members. Refer to the Operating Instructions (see Section 1.3.3) for a description of all patient parameter cartridges.

NOTE: Software versions up to and including VE0 support only 1 SIREM in a single monitor.

1.5. Technical Data

Refer to Figure 1-1 for technical data pertaining to System SIRECUST 1280 monochrome and 1281 color monitors.

TECHNICAL DATA: SIRECUST 1280/1281 MONITORS	
Line Voltage Requirements	90 to 132 VAC or 180 to 264 VAC, @ 48 to 62 Hz
Power Consumption (including 1 SIREM configured with 1 LIM cartridge, 1 Pressure cartridge, and 1 pCO ₂ cartridge)	155 W, SIRECUST 1280 (monochrome) 175 W, SIRECUST 1281 (color)
Protective Class	VDE 0750 Class 1, IEC 601-1 Class CF, UL544, CSA 22.2 number 125
Leakage current (housing)	≤100 μ A @ 121 VAC 60 Hz (in accordance with UL544); ≤500 μ A @ 242 VAC 50 Hz (in accordance with IEC 601-1)
Operating Temperature	Operation: +10°C to +40°C Storage: -40°C to +75°C
Cooling	Convection (no fan)
Relative Humidity	Operation: 30% < R.H. < 95% Storage: 10% < R.H. < 100%
Color	Housing: gray-white. Front panel: gray-brown. Rear: silver-metallic
Dimensions	10.5 in (266 mm) H x 17.25 in (439 mm) W x 14.25 in (360 mm) D
Weight	36 lb. (16.5 kg)

Figure 1-1: Technical Data

TECHNICAL DATA: SIRECUST 1280/1281 (Continued)General Display Functions

Display Screen Size	12 in (30 mm) diagonal, 9 in (233 mm) x 7 in (170 mm) usable area
Deflection Speed	6.25, 12.5, 25, and 50 mm/s
Depiction mode	"paper mode"
Trend	4 pages; up to 23 different parameters over 24 hours
Brightness	Manually adjustable, automatic adjustment to ambient lighting

SIRECUST 1280 - Monochrome display

Raster Resolution	600 x 400 pixels
X-Y Resolution/channel	1920 pixels (horizontal) x 2040 pixels (vertical)
Bandwidth	100 HZ at 13 mm, 50 mm/s
Depiction color	Yellow-green

SIRECUST 1281 - Color Display

Raster Resolution	480 x 320 pixels
X-Y Vertical Resolution/channel	1920 pixels (horizontal) x 2040 pixels (vertical)
Bandwidth	100 HZ for curves 1 and 2, at 14 mm amplitude and 50 mm/s; 50 Hz for curves 3 thru 8, at 50 mm/s
Depiction Colors	Red, green, yellow, and orange

Figure 1-1: Technical Data (Continued)

1.6. Maintenance Recommendations**1.6.1. Cleaning and Disinfecting**

Refer to the Operating Instructions, SIEMENS Order No. A91004-M3331-L079-XX-7600 for recommendations regarding regular cleaning and disinfecting.

1.6.2. Optimizing Monitor Performance

To assure optimum performance of SIRECUST 1280/1281 monitors, SIEMENS recommends that a complete operational check be performed annually. Follow the procedures of Chapter 5, Functional Verification, and Chapter 7, Calibration/Adjustment, Sections 7.1 and 7.2. Record results on the form provided in Appendix F.

CHAPTER 2

MONITOR OPERATIONS

TABLE OF CONTENTS

2.	OVERVIEW OF MONITOR OPERATIONS	1
2.1.	Power OFF/ON	1
2.2.	Control Keys	2
2.2.1.	Fixed Keys	2
2.2.2.	Parameter Keys	2
2.2.3.	Program Keys	2
2.3.	Screen Formats	2
2.3.1.	Help Screen	2
2.3.2.	Main Screen	2
2.3.2.1.	Message Area	2
2.3.2.2.	Menu Area	2
2.3.2.3.	Keypad Area	3
2.3.2.4.	Waveform Area	3
2.3.2.5.	Parameter Key and Display Area	3
2.3.2.6.	Limits Display Area	4
2.3.3.	Trend Screen	4
2.3.3.1.	Message, EKG Waveform, Heart Rate Parameter Areas	5
2.3.3.2.	Trend Graph/Menu Areas	5
2.3.4.	Remote Screen	5
2.4.	TouchScreen Calibration	6

LIST OF FIGURES

Figure 2-1.	Main Screen Display	1
Figure 2-2.	Main Screen Display with All Areas Activated	3
Figure 2-3.	Trend Screen Display	4
Figure 2-4.	Touch Screen Calibration Display	5

2. OVERVIEW OF MONITOR OPERATIONS

This Chapter is intended to be used as only a brief overview to assist qualified service personnel in servicing the monitor. For detailed instructions and monitor operations consult the Operating Instructions and Supplement for the installed software version, SIEMENS Art. No. A91004-M3331-L079-XX-7600.

2.1. Power OFF/ON

1. Plug the monitor main power input cable into a hospital-grade power outlet of proper operating voltage.

NOTE: Refer to Chapter 3, Section 3.8 and the procedures outlined in Chapter 4, Section 4.1., if necessary to verify or change the operating line voltage for which the monitor has been configured.

When viewed from the back of the monitor, the main power input cable plugs into the connection near the bottom right corner. A rocker switch located just above the power input socket controls main power OFF/ON.

2. Toggle the main power switch ON.

The green POWER INDICATOR LIGHT in the lower right corner on the front panel illuminates. The unit performs a self-test and displays a series of messages, e.g.

- TESTING DISPLAY BOARD PROMS
- TESTING GDC MEMORY
- TESTING FRONT END BOARD PROM
- TESTING FRONT END BOARD RAM

The exact sequence and number of messages is software dependent. Upon successful completion of the self-test, the main screen display appears. Figure 2-1 depicts a typical main screen display.

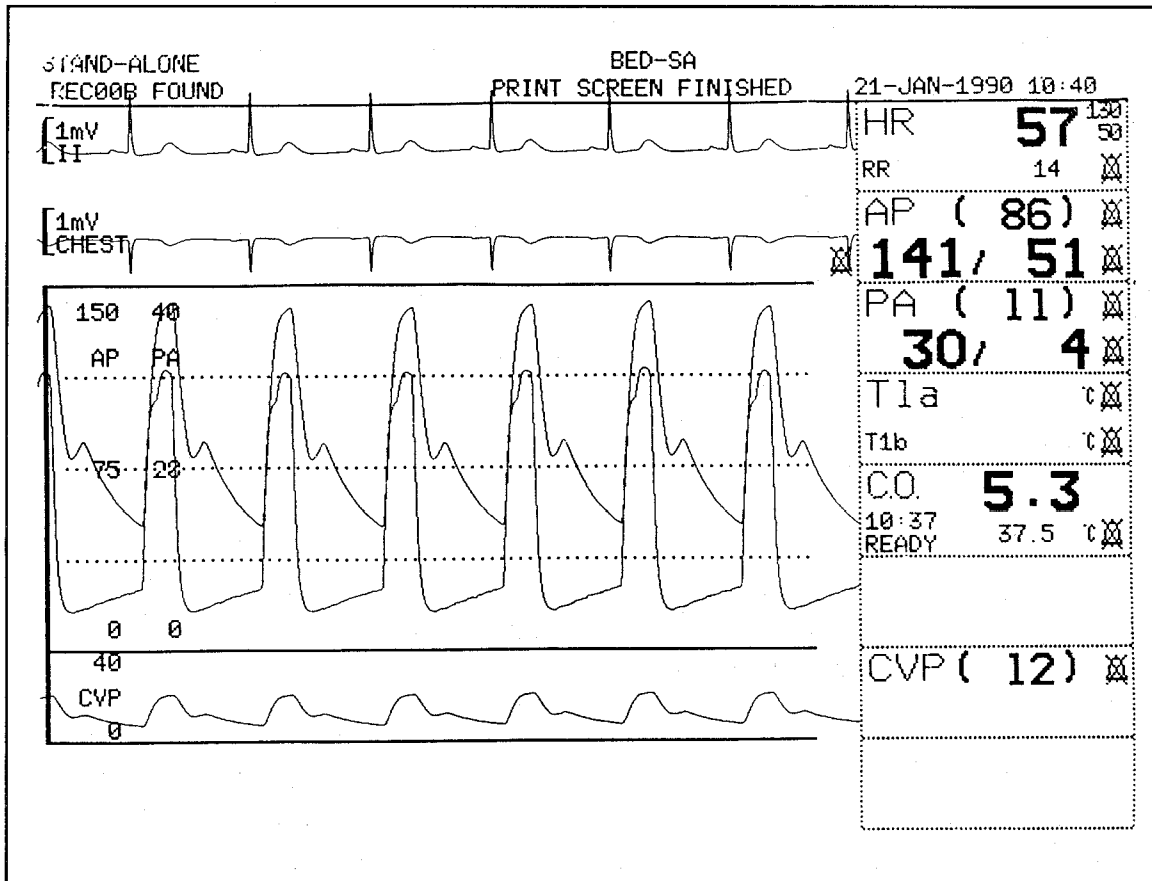

Figure 2-1. Main Screen Display

2.2. Control Keys

Three types of keys are used for operating the monitor --

- Fixed Keys
- Parameter Keys
- Program Keys

Control keys are positions on the front panel that are touch sensitive. Activate a key by direct, firm, finger pressure in the center of the key. The monitor responds with a short beep to acknowledge that pressing the key position on the Touch-Screen has successfully generated a control signal input.

2.2.1. Fixed Keys

Frequently used functions such as ALARM SILENCE or PRINT SCREEN are activated by fixed keys located on the front panel to the right of the screen.

Fixed key functions are independent of the current display.

NOTE: CALC., C, and D are inactive keys with software versions VE and below. Pressing them produces no response in the monitor.

2.2.2. Parameter Keys

Parameter fields function as keys to access the entry menu into a parameter's menu tree. Pressing the key causes it to flash briefly. Refer to Section 2.3.2.5. for additional information.

2.2.3. Program Keys

Program keys appear when their parent menu is accessed, and control all functions within the menu. Their function and position vary with different menus.

2.3. Screen Formats

Three screen formats are available -- Main Screen, Trend Screen, and Remote

Screen. A Help Screen can also be accessed to assist in operating the monitor.

To access a specific screen format, press the key with the same name, MAIN, TREND, REMOTE or HELP, located in the fixed key area on the right side of the front panel.

2.3.1. Help Screen

The Help screen explains the Touch-Screen and menu-driven operation of the monitor.

2.3.2. Main Screen

The Main Screen is the monitor's default screen, and is divided into six areas. When all areas are activated at the same time the screen appears as illustrated in Figure 2-2. The areas are --

1. Message area
2. Menu area
3. Keypad area
4. Waveform area
5. Parameter key and display area
6. Limits display area

2.3.2.1. Message Area

The message area is always active, and occupies the narrow band across the top edge of the screen. It displays the following information:

- systems and alarm messages
- bed numbers
- time, and date.
- diagnostic messages (when activated under the field service menu)

2.3.2.2. Menu Area

When activated, the parameter menu area for the Main screen occupies 30%-40% of the left side of the screen. It overlays part of the waveform display area, and contains program touch keys for accessing parameter functions. When not activated,

the area extends the waveform display area. See Section 2.3.2.4.

2.3.2.3. Keypad Area

The keypad, when activated, appears in the waveform field and overlays all waveforms except the real-time EKG waveform at the top of the screen. Refer to Section 2.3.2.4. Enter numerical data, such as alarm limits, on the keypad. Always press the ENTER key to complete an entry.

2.3.2.4. Waveform Area

The waveform area can display up to eight waveforms and is the largest of the display areas, occupying up to approximately 70% of the screen. The actual size of the waveform area varies with activation/deactivation of the menu and keypad

areas.

From top to bottom, the waveform area is divided into three smaller areas --

- Real-time EKG area: occupying the top portion,
- Pressure area: occupying the middle portion, and
- General waveform display: occupying the bottom portion.

The size of the individual areas can vary depending on the actual number and kind of patient parameters being monitored.

2.3.2.5. Parameter Key and Display Area

The parameter key and display area is

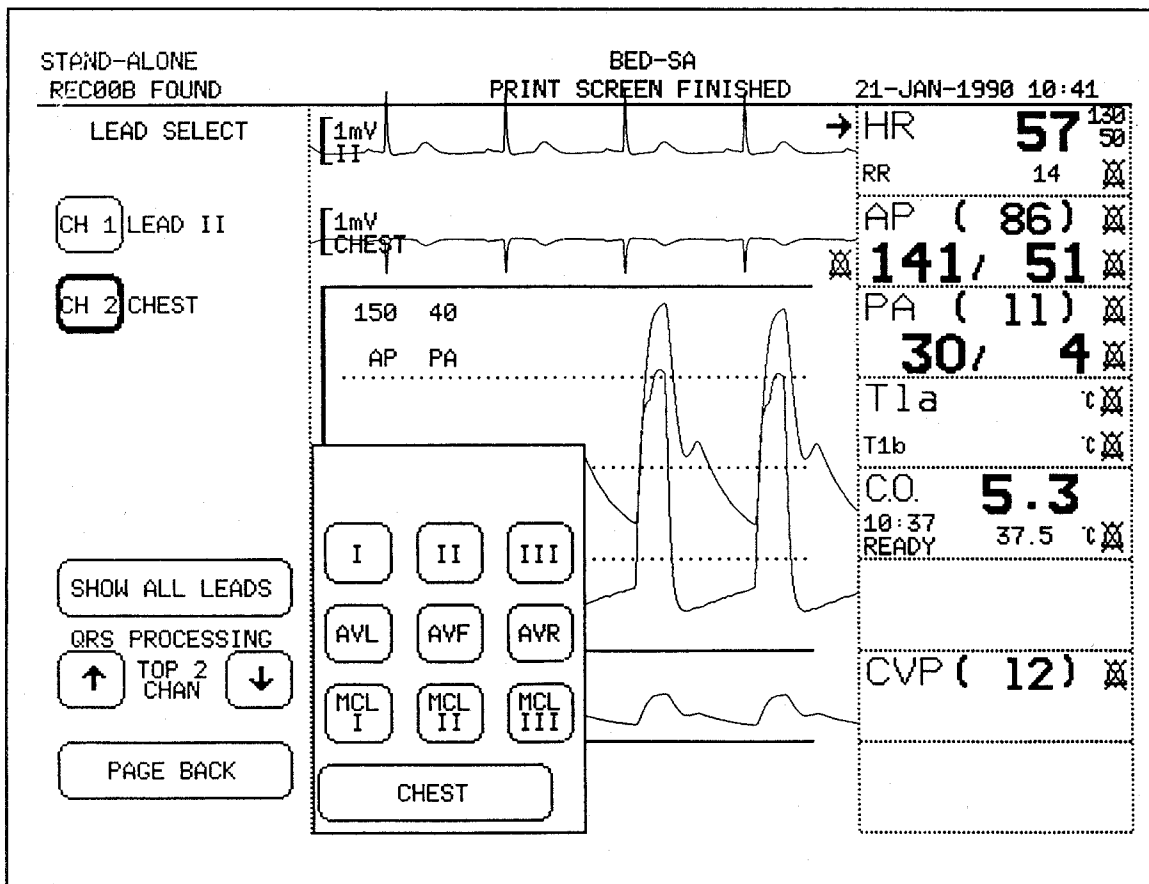

Figure 2-2. Main Screen Display with All Areas Activated

located on the right-hand side of the screen immediately adjacent to the fixed key area, and is divided into four, six, or eight boxed areas referred to as parameter fields. An entire parameter field acts as a key to access the parameter's menu. Each waveform is displayed next to its specific parameter. An arrow next to a field indicates that the parameter menu corresponding to that is active.

Fields may contain symbols and messages. Content varies from parameter to parameter as well as within a parameter, depending on selections made. Figure 2-2 illustrates the locations of the various areas on the display screen.

NOTE: With VF0 software, if more than one parameter is contained in a field, the "primary" parameter display is larger than the "secondary" parameter display.

2.3.2.6. Limits Display Area

Limits display areas for up to two sets of alarm limits have been incorporated into the parameter key and display boxes. Limits are displayed whenever an alarm has been enabled. For pulsatile pressures, a third limits display appears in the waveform field immediately adjacent to the systolic pressure label. Crossed-bell symbols replace limits when alarms have been disabled.

2.3.3. Trend Screen

The trend screen contains six display areas, as shown in Figure 2-3. They are --

- Message area
- Real-time EKG waveform area

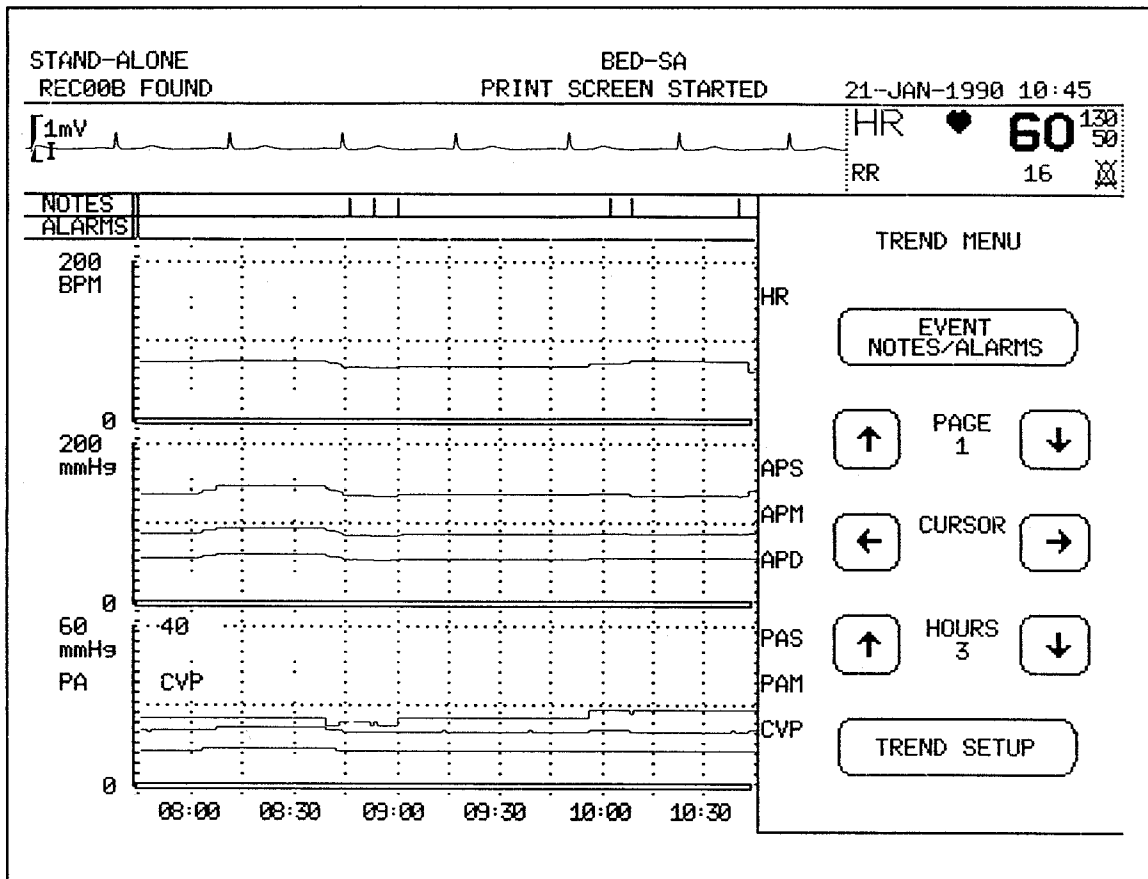

Figure 2-3. Trend Screen Display

- Heart rate parameter area
- Trend graph area
- Trend menu area
- Notes/alarm area

2.3.3.1 Message, EKG Waveform, Heart Rate Parameter Areas

The message, real-time EKG waveform, and heart rate parameter areas of the trend screen are identical to the corresponding areas of the Main screen.

2.3.3.2 Trend Graph/Menu Areas

The trend graph area replaces all except the real-time EKG waveform in the waveform area of the main screen, and

the trend menu replaces the parameter area except for the heart rate parameter field. Trend menus cannot be deactivated and removed from the trend screen.

2.3.4. Remote Screen

The remote screen function enables patient data from a remote bed to be displayed at a local monitor. The screen has several display modes --

- Entire screen of a remote bed
- Portions of the main screen of a remote bed and the local bed
- Cluster screen

Refer to Chapter 8 in the Operating Instructions manual for a detailed discussion of the remote screen function.

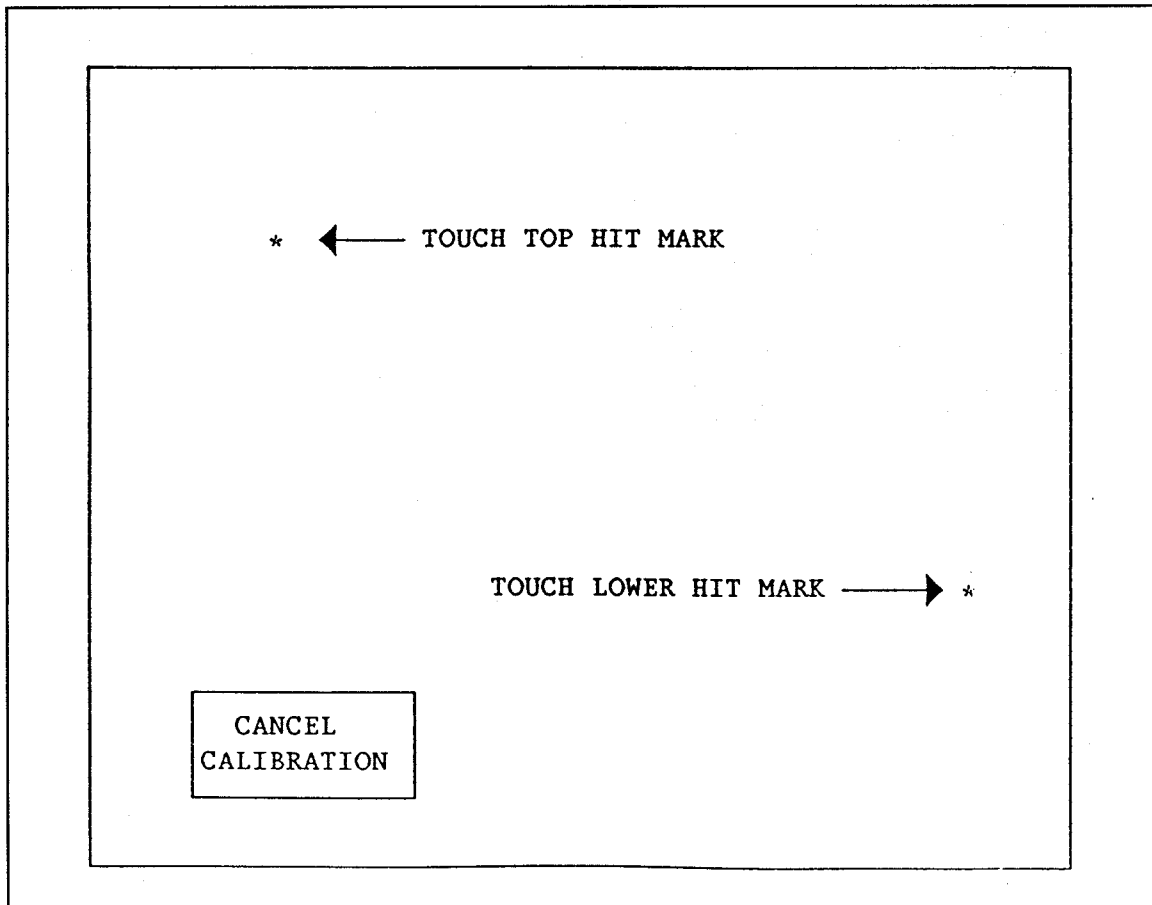

Figure 2-4. Touch Screen Calibration Display

2.4. TouchScreen Calibration

The calibration process identifies specific screen positions to the software, so that the software can correctly relate positions on the TouchScreen to specific operator commands when the operator touches the screen. See Figure 2-4. This procedure is considered to be an operational calibration to be performed at the bedside, and should rarely be required in normal monitor operations. Refer to Troubleshooting, Chapter 6, if monitor fails to retain TouchScreen calibration.

NOTE: Fixed keys are inactive during TouchScreen calibration.

1. After the monitor completes its start-up self-tests, exert gentle finger pressure anywhere on the left half of the display screen before you touch any other option of the screen, to initiate the calibration program.
2. Touch each mark on the resulting display as directed by the prompts that appear on the screen.

NOTE: Press CANCEL CALIBRATION at anytime to abort the calibration program.

The message CALIBRATION FINISHED appears briefly at the end of the calibration process, and the display changes to the main screen display.

CHAPTER 3

INTERNAL MONITOR FUNCTIONS

TABLE OF CONTENTS

3.	INTERNAL MONITOR FUNCTIONS	1
3.1.	Introduction	1
3.2.	Front End Board	3
3.2.1.	PROM/RAM Interface	3
3.2.2.	Parameter Cartridge Timing	3
3.2.3.	SIREM Power Control	4
3.3.	Display Processor	4
3.3.1.	Registers	7
3.3.2.	Timing	7
3.3.3.	Interrupts	7
3.3.4.	Arbiter	8
3.3.5.	Graphics Controller	8
3.3.6.	System Synchronization	8
3.3.7.	Reset	8
3.3.8.	Select Lines	9
3.4.	Curve Board	9
3.4.1.	Waveform Generation	9
3.4.1.1.	Vertical Deflection Control	9
3.4.1.2.	Horizontal Deflection Control	9
3.4.2.	Timing	11
3.4.3.	Blanking Circuit	11
3.4.4.	Registers	11
3.4.5.	Curve Board Display Signal	12
3.4.6.	Network Controller	12
3.5.	Deflection Board	12
3.5.1.	Horizontal Deflection - 1280 Monochrome Monitors	12
3.5.2.	Horizontal Deflection - 1281 Color Monitors	15
3.5.3.	Vertical Deflection - 1280 Monochrome Monitors	15
3.5.4.	Vertical Deflection - 1281 Color Monitors	15
3.5.5.	Power-saving Circuitry	16
3.6.	Z-Amp Board	16
3.6.1.	High-voltage Power Supply	16
3.6.2.	Z-Amp (Intensity)	17
3.6.3.	Blanking Circuit	17
3.7.	Operator Interface Board	18
3.7.1.	Microcomputer	18
3.7.2.	TouchScreen	18
3.7.3.	Ambient Brightness Monitor	21

TABLE OF CONTENTS (Continued)

3.8.	Power Supply	23
3.8.1.	Main Inverter	23
3.8.2.	Auxiliary Inverter	24
3.9.	Monitor Display	25
3.9.1.	Color Shutter	26
3.10.	Option Boards	27
3.11.	Clock Board	27
3.12.	Master Option Board	27
3.12.1.	68008 Processor and Associated Circuitry	27
3.12.2.	Direct-Memory-Access Control	27
3.12.3.	Addressing and Controlling Data Exchange	28
3.12.4.	RAM/ROM and Real-Time Clock Circuitry	28
3.12.5.	Sub-Option Board Locations	31
3.13.	Analog Sub-Option Board	32
3.13.1.	Functional Operation	33
3.13.2.	Location vs. Signal Priority	33
3.14.	RS-232 Serial Sub-Option Board	33
3.14.1.	Functional Operation	33
3.15.	4-Channel Analog Option Board	35
3.16.	Memory Extension Board	37
3.17.	Motherboard	37
3.18.	Line Driver Board	37
3.19.	Memory Backup	37
3.20.	Operational Support Equipment	37
3.20.1.	Remote Cartridge Unit (SIREM)	37
3.20.2.	LIM Cartridge	39

LIST OF FIGURES

Figure 3-1.	SIRECUST 1280/1281 Monitors: Basic Block Diagram	1
Figure 3-2.	SIRECUST 1280/1281 Monitors: Board and System Component Interconnections	2
Figure 3-3.	Channel Conversion Memory Map	4
Figure 3-4.	Front End Board Block Diagram	5
Figure 3-5.	Display Processor Block Diagram	6
Figure 3-6.	VME BUS Timing	7
Figure 3-7.	Curve Board Timing (Monochrome Display)	10
Figure 3-8.	Curve Board Timing (Color Display)	10
Figure 3-9.	Curve Board Block Diagram	13
Figure 3-10.	Deflection Board - Block Diagram	14
Figure 3-11.	Z-amplifier Board Block Diagram	19
Figure 3-12.	Operator Interface Board Block Diagram	20
Figure 3-13.	TouchScreen Circuit Function	21
Figure 3-14.	Power Supply - Block Diagram	22
Figure 3-15.	Positioning X4	23
Figure 3-16.	Typical Waveform Screen	25
Figure 3-17.	Combined XYZ and Raster	26
Figure 3-18.	Master Option Board Block Diagram	29
Figure 3-19.	Analog Sub-Option Board Block Diagram	30
Figure 3-20.	RS-232 Serial Sub-Option Board Block Diagram	30
Figure 3-21.	Master Option Board: Sub-Option Board Locations	31
Figure 3-22.	Monitor with SIREM and LIM	38

LIST OF TABLES

Table 3-1.	A140/A280 Power Supply Test Points	24
Table 3-2.	Sub-Option Board Location/SDL Connector/Output Relationships	32
Table 3-3.	MOB Output Table	32
Table 3-4.	MOB SDL Connector Signal Assignments	32
Table 3-5.	ASO Input/Output Connector Table	34
Table 3-6.	Input/Output Connector Table	34
Table 3-7.	MOB Jumper Table	35
Table 3-8.	SSO Input/Output Connector Table	36

3. INTERNAL MONITOR FUNCTIONS

3.1. Introduction

Sensors develop electrical signal analogs for a variety of patient vital signs (physiological functions). The electrical signals are digitized and converted into infrared signals by specialized physiological parameter cartridges, and conveyed via SIREM units (refer to Section 3.20.) to the input circuits contained on the Front End Board in SIRECUST 1280/1281 monitors. Sub-systems within the monitors process the signals to develop visual displays of the information contained in the signals. The monitor sub-systems also initiate visual

and audible alarms when indicators of patient vital signs are outside of pre-defined limits, and provide digital as well as analog electrical signal outputs for use with equipment external to the monitor.

Basically, then, monitors have three functional sub-systems -- processing and display of information relative to patient vital signs, provision for human control of monitor operations, and a system for supplying power to all circuits. Figure 3-1 is a block diagram illustrating the basic system functions, and depicts, in part, which boards form each of the three basic sub-systems. Figure 3-2 illustrates the interconnection of boards and system components in the monitors.

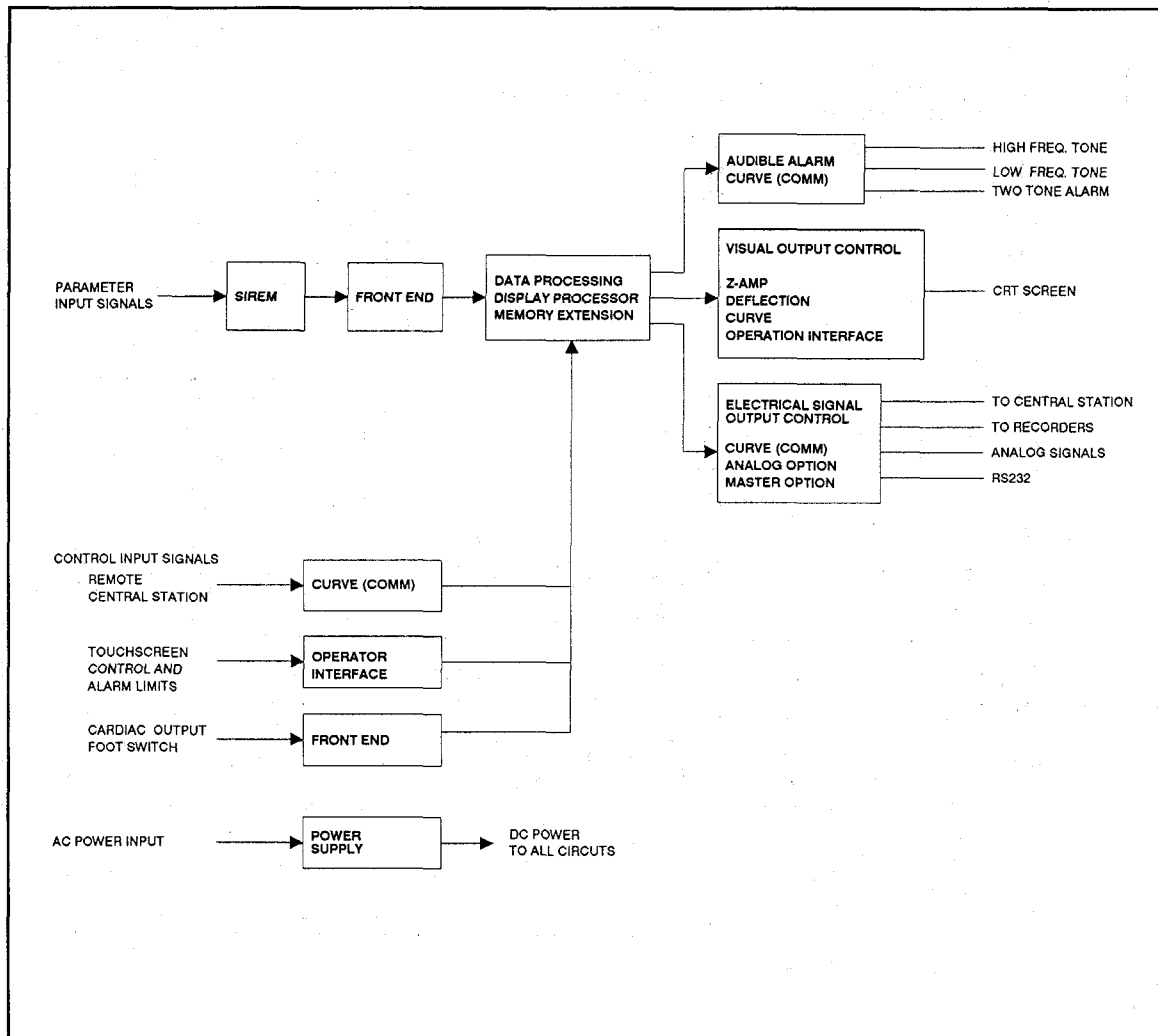

Figure 3-1. SIRECUST 1280/1281 Monitors: Basic Block Diagram

System SIRECUST 1280/1281 Bedside Monitor - Service Manual

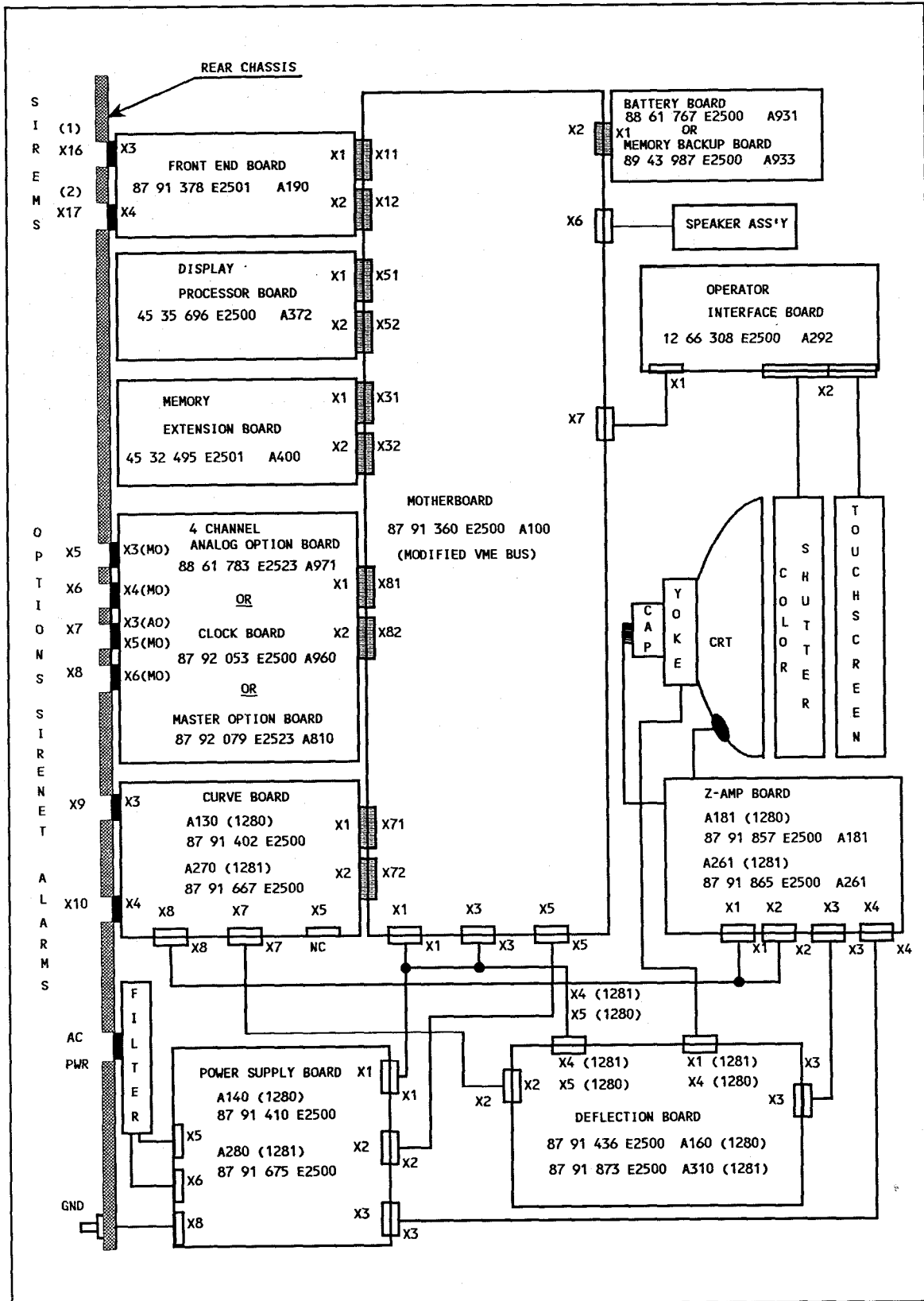

Figure 3-2. SIRECUST 1280/1281 Monitors: Board and System Component Interconnections

3.2. Front End Board

The Front End Board contains circuitry for data collection and control of the physiological parameter cartridges via SIREMs. It generates the time clocks for data exchange between the SIREMs and the Display Processor, and converts the serial data streams from the SIREMs into parallel data streams. It is also the interface for the +15 V_{DC} needed by the SIREM to power cartridges. Refer to Figure 3-4 and the schematic diagram in Appendix B.

The four main sections of the board are:

- dual access RAM (D-RAM) (J57, J59, J68, J69) for storage and retrieval of data from the parameter cartridges,
- logic and timing generation circuits for parameter cartridge communication,
- parameter cartridge power control,
- additional static RAM (J43, J44) and EPROMs J17, J18, J33, and J34, (see NOTE:) for the main CPU.

NOTE: Software versions up to and including VCx use EPROMS on A190 Rev.1 and Rev 2. Front End Boards, Art. No. 87 91 378 E2501. For software versions VEx and subsequent versions, EPROMS in positions J17, J18, J33, and J34 on the Memory Extension Board supplant use of EPROMS on the Front End Board. See Section 3.16.

3.2.1. PROM/RAM Interface

The PROM/RAM interface consists of a 2K x 8 bit static RAM and 16 Kbytes of dual access D-RAM. The D-RAM is configured for dual access using the system address bus and the bus arbiter located on the Display Processor Board. D-RAM is used for storage of configuration codes for transmitting to the parameter cartridges and for storage of auxiliary and data bits received from the cartridges.

The PROM and SRAM are accessed by the system BUS, whereas D-RAM may be accessed by either the system BUS or by internal logic. Access to PROM and SRAM is controlled by an address decoder and timer. Access to D-RAM by internal circuits is gained by arbiting for the system BUS for address access to D-RAM. When D-RAM is accessed by internal logic, the data is passed on the internal data BUS (D100-D115) while the system data BUS is disabled.

3.2.2. Parameter Cartridge Timing

Timing is synchronized to the 50 Hz DISPLAY field rate by the field bit signal. Parameter cartridge timing generation can be divided into three basic sections:

- a prescaler which divides the 4 MHz clock to generate the six micro-second clock needed by cartridges,
- a conversion timing generator which generates all the timing associated with each conversion, and
- the conversion address counter.

Operation of a parameter cartridge is controlled by configuration control words CCA-CCD, and by control bits U/LA-U/LD which direct the CC words to the upper or lower cartridge pairs. The CC words and U/L control bits are read from predetermined locations in the D-RAM and transmitted to the appropriate cartridge. Data and Aux words are received and stored in predetermined locations in D-RAM. Each 20 ms period is divided into 96 conversions of 208.25 μ s each. The 96 conversions are mapped into D-RAM according to the channel conversion memory map. "Ping," "Pong," and memory mapping assure synchronous software access to the data. Refer to the Front End Board memory map in Figure 3-3. The serial CC and data/aux bit streams are transmitted to and received from the SIREMs using differential drivers and receivers.

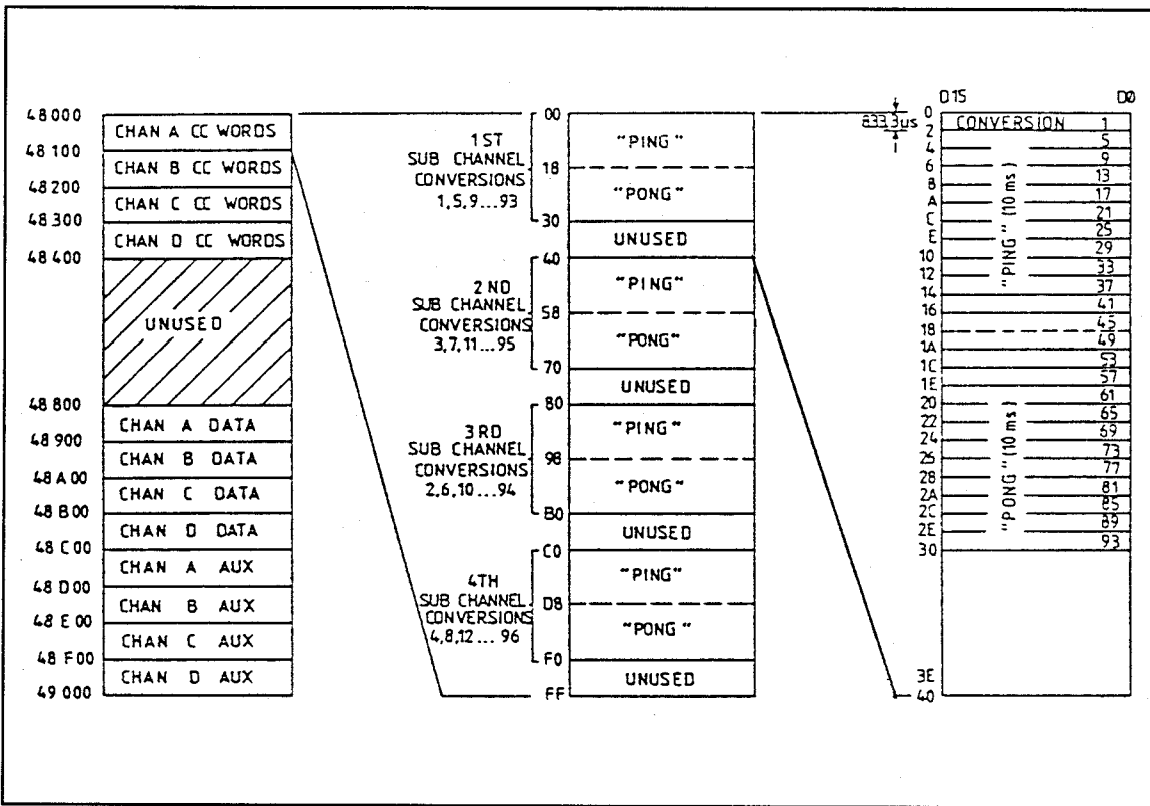

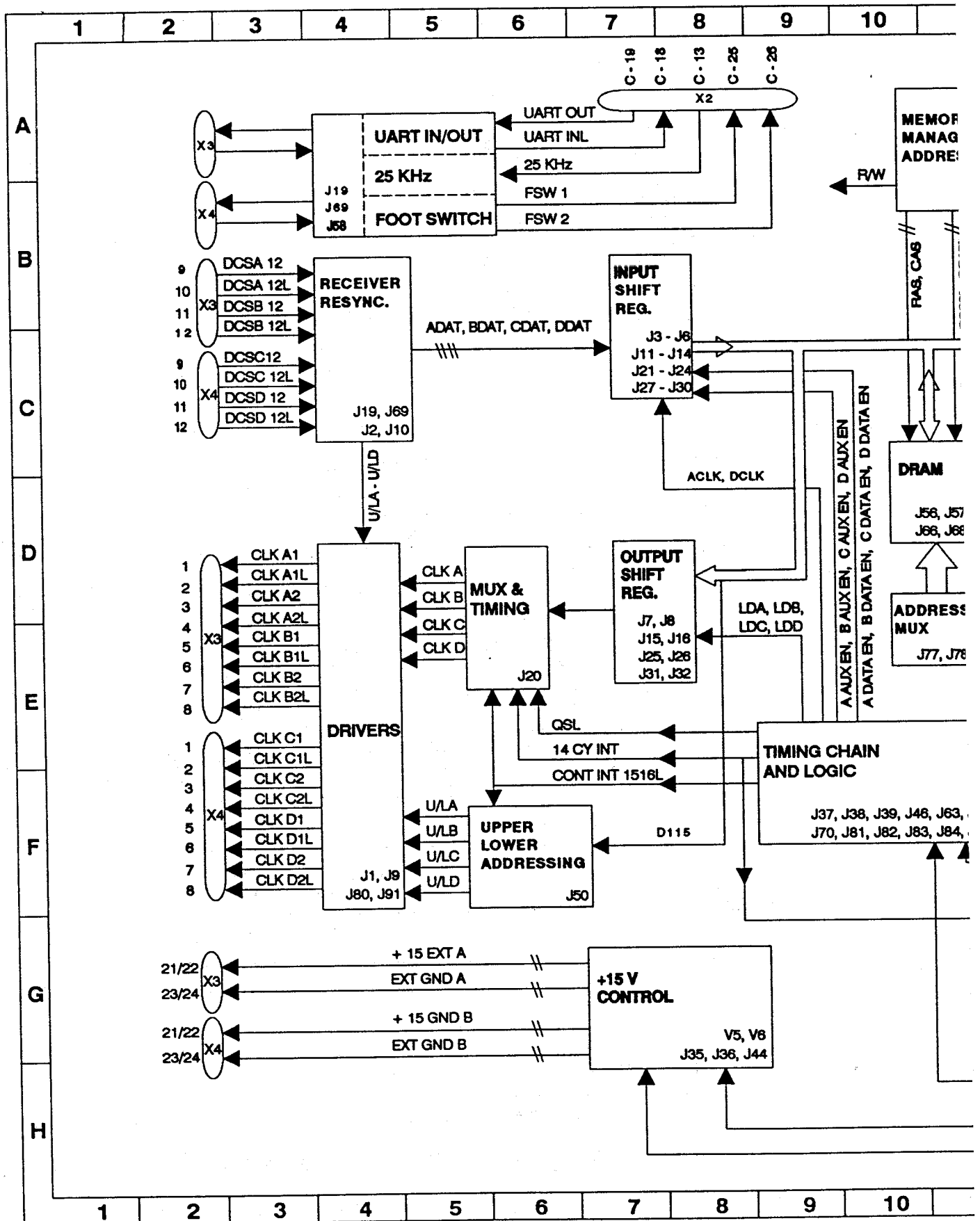

Figure 3-4. Front End Board Block Diagram

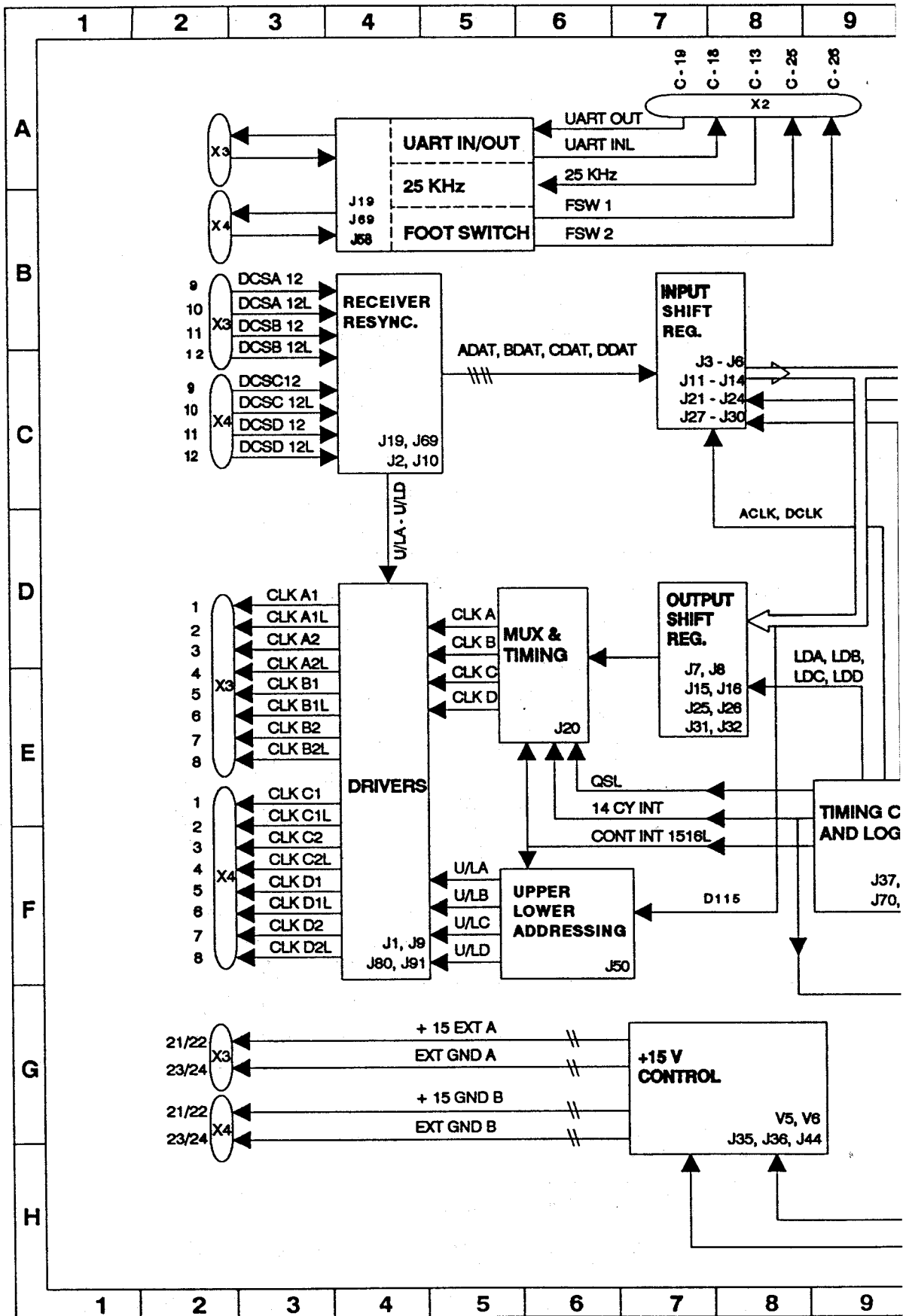
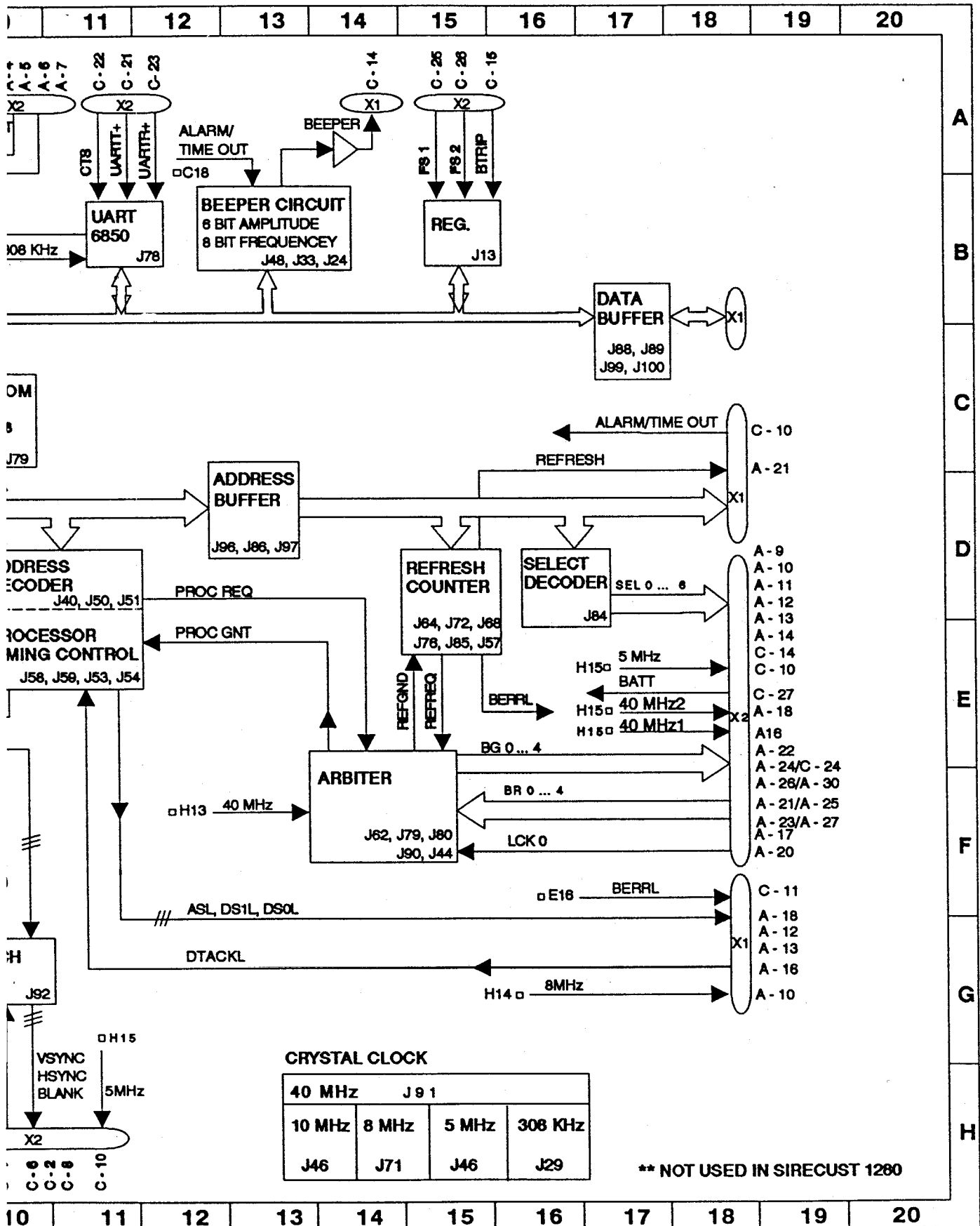

Figure 3-4. Front End Board Block Diagram



CRYSTAL CLOCK

40 MHz J91			
10 MHz J46	8 MHz J71	5 MHz J46	308 KHz J29

** NOT USED IN SIRECUST 1280

To initiate a cycle the 68000 activates its address strobe and data strobes. For a byte cycle only one of the data strobes will be activated. For a word cycle both data strobes will be activated. Since the 68000 is an asynchronous device, the 68000 will wait for an acknowledgement.

The acknowledgement signal is called DTACK. For an external BUS cycle, the address strobe, data strobes, and DTACK signal are synchronized through the arbiter and passed to the external BUS.

3.3.1. Registers

The display board has several registers which control different tasks. The BEEPER circuit contains a 6 bit amplitude register and an 8 bit frequency register. A filter and power amplifier drive the speaker. An input to the BEEPER circuit, called the watch dog alarm, is activated by other processors in the system in the case that a processor crashes. Another register, J13, on the internal BUS brings in inputs

from the battery board called AC LOW, and also one signal from either of the cardiac output module foot switches on the two SIREM units.

A 19.2 kBaud UART link, J78, on the internal BUS of the 68000 interfaces with the 68705 processor on the Operator Interface Board.

3.3.2. Timing

Refer to Figure 3-6. Main timing for the unit is a 40 MHz crystal, Y1, with a tolerance of ± 0.01 percent. The 40 MHz is bus-sed on the Motherboard to control all system timing on other boards. 40 MHz is divided down to 10 MHz for the 68000, to 8 MHz for a system clock, to 308 kHz for the UART, and to 5 MHz for the graphics controller. See Section 3.3.5

3.3.3. Interrupts

Seven interrupts come into the board. Six are general purpose interrupts and

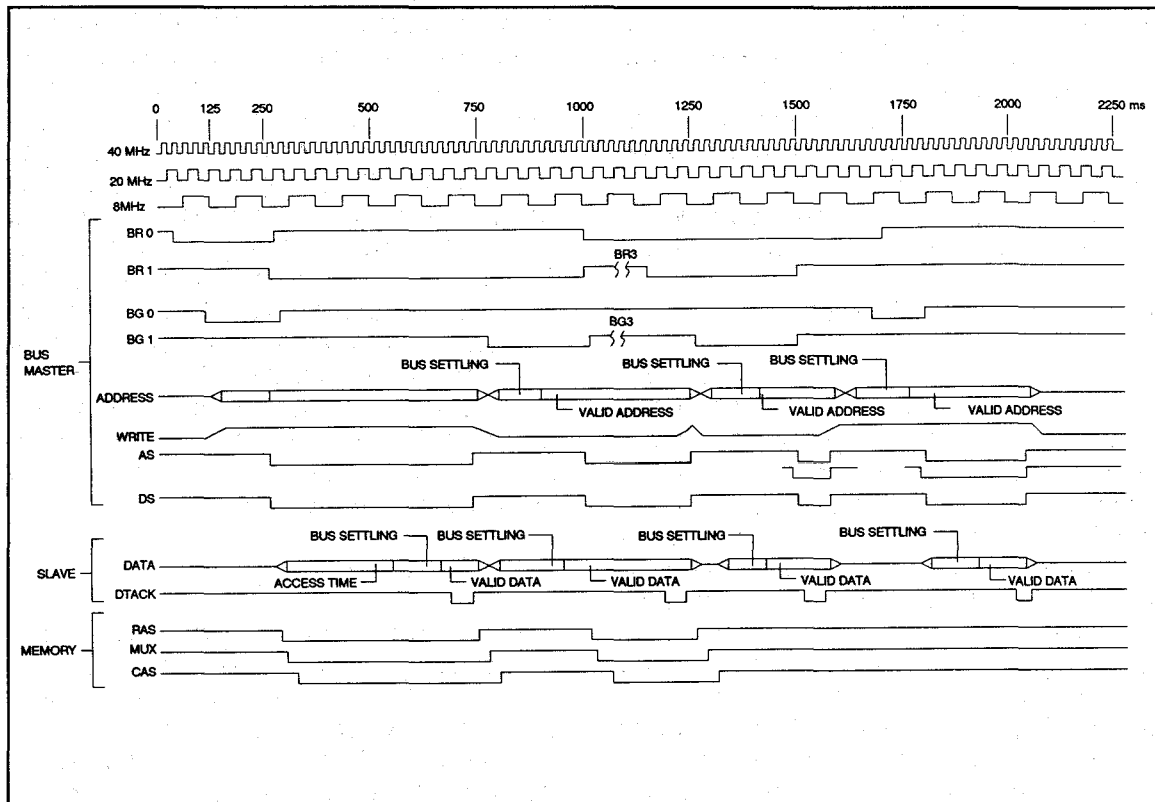

Figure 3-6. VME BUS Timing

one is for ac power fail, AC LOW. The interrupts are prioritized and sent to the processor as one of three levels. Level seven is the highest and is reserved for the ac power fail interrupt. Level five is a timing interrupt from the curve board. All other interrupts are level three. Register J26, associated with the interrupts, supplies the interrupt vector during an interrupted acknowledge cycle.

3.3.4. Arbiter

The Motherboard is a modified (low power) VME bus for multiprocessor application. An arbiter arbitrates up to five BUS masters external to the board, the on-board 68000, and refresh. A refresh counter requests a cycle every 15 μ s and performs a system wide refresh on the BUS. The refresh counter is also used as the arbiter's time out. If the refresh circuit does not receive a grant within its 15 μ s, a timeout BUS error is generated. The five external BUS requests are arbitrated in a priority manner. Arbitration takes 50ns. A signal, BUS LOCK, is used for multiple processors on the BUS. The lock signal is used for a read-modify-write cycle and is activated between the read and the write cycle. Since the read and write of a read-modify-write cycle are arbitrated separately, the lock signal inhibits other processors from gaining arbitration while a read-modify-write cycle is in progress.

3.3.5. Graphics Controller

The graphics controller, J32, is a NEC 7220 and controls the basic video timing as well as the bit map for the raster display. The graphics controller interfaces to a 16K x 16 bit DRAM, J7 ... J10 and J15 ... J18, (J7 ... J10 are not used in monochrome monitors) and to a 64K x 16 bit SRAM, J60 and J61. The graphics controller refreshes the video screen by supplying the proper address to the dynamic RAMs which then provide the data to the shift registers. The output of the shift registers is the dot information for the raster display. The dot rate (pixel

rate) is 40 MHz. The 7220 also performs the update for the screen. After given a command by the 68000 through an 8 bit BUS, the graphics controller performs read-modify-write cycles to the dynamic RAM. Communication between the 68000 and the graphic controller is an 8 byte FIFO contained in the graphic controller. The graphic controller video timing consists of two SYNC signals and a BLANKING signal. The SYNC signals, horizontal sync and vertical sync, are provided by the graphic controller. Since this system uses a vertical raster, the horizontal sync signal is actually used to synchronize the vertical raster lines. The video timing signals, along with the pixel information, are sent to the curve board to generate a picture.

3.3.6. System Synchronization

In a network of several bedside and central computers synchronization of the time base of all system units is important. Even with crystal accuracy of 0.01%, over a long period the time reference in the different units would drift apart. Therefore, the clock to the graphic controller is intercepted with a system synchronizer, J25. The system synchronization is under control of the 68000. By writing to this register, the 68000 can lengthen the overall timing of the graphic controller by slowing down the clock during vertical sync. System synchronization is implemented over the SIRENET link with a broadcast message from the network controller that tells the 68000 exactly when a 300 ms cycle ends. The 68000 then adjusts the timing to the graphic controller to match the 300 ms interval. This is essentially a software phase lock loop.

3.3.7. Reset

A reset signal broadcast on the Motherboard during power-up resets the 68000. The 68000 may also execute a reset instruction which causes a reset to the Motherboard but allows the 68000 to continue to run. Reset may also be

initiated by the Battery/Memory Backup Board when the main power voltage drops below 4.7 volts.

3.3.8. Select Lines

An area of the memory map, containing decoded register lines called select lines, is reserved to control each of the boards. Each of 7 select lines is decoded to 4 kBytes. The lines are wired to the 7 slots in the Motherboard (not counting the display processor's Motherboard slot). The select lines are decoded from the external address BUS, so that other BUS masters may access the select address space by providing the proper address.

3.4. Curve Board

The curve board is divided into two separate functions. Refer to Figure 3-9. One third of the board is used for the SIRENET communication link, and the other two thirds of the board drive the display. The communications function of the board is based on the Intel 8344 microcontroller.

Basic timing for the curve board is a 10 ms raster followed by a 10 ms curve time in the 1280 and 5 ms raster followed by 5 ms curve time in the 1281. See the signal Y-AMPL in Figure 3-7 and Figure 3-8. The curve time contains 8 curve sweeps. The raster has 600 lines by 400 dots resolution in the 1280, and 480 lines by 320 dots in the 1281. Each curve is approximately 1 ms long. Since the total time for both curves and raster is 20 ms the screen refresh rate is 50 Hz providing a flickerfree display.

This board is also used to generate a color picture through control of the Color Shutter. Refer to Section 3.9.1.

The display layout always defines the right side of the screen as the parameter value section. This means that the curve display area must be reduced to 3/4 of the screen, leaving the right hand side of

the screen for parameter boxes. The vertical bandwidth for both color and monochrome is 500 kHz, which translates to 100 Hz bandwidth/13 mm amplitude at 50 mm per second for all 8 waveforms (monochrome only).

3.4.1. Waveform Generation

The waveform (or curve) portion of the board generates X and Y deflection signals for the deflection amplifier, as well as a blank and intensity signal for the Z amplifier. Refer to Sections 3.5 and 3.6.

3.4.1.1. Vertical Deflection Control

Vertical (Y) deflection control originates in two sources. The first source is a vertical ramp generator used for raster. The second source is an 11 bit DAC, J33, used for sweeping waveforms out of curve memory. Curve memory is a 16K x 12 bit DRAM, J32, J43, and J52. The address for the DRAMs originates in either the system BUS or the display counters. When curves are swept on the screen, the counters are loaded to a sweep start address. Half way through the sweep, the counter may be reloaded with a second sweep start address. Amplifiers which drive the deflection yoke for vertical deflection are contained on the Deflection Amplifier Board. See Section 3.5.3, 3.5.4.

3.4.1.2. Horizontal Deflection Control

Horizontal (X) deflection control originates in four sources. The first source is the horizontal ramp generator for the raster, which is 10 ms long for monochrome and 5 ms long for color. The other two sources are two different horizontal ramp generators, so that curves with different X resolutions may be swept out in the color monitor. This is required because the color monitor requires twice the display speed for the green and red display. The X sweep speed is optimized for EKG and pressure waveforms. Pressure waveforms are limited to 50 Hz and can therefore be swept faster than the EKG waveforms.

With 100 Hz resolution, EKG waveforms are swept slower to allow time for deflection of the beam. In color monitors only the two top channels are designed for 100 Hz resolution. Amplifiers which drive the deflection yoke for horizontal deflection are contained on the Deflection Amplifier Board. See Section 3.5.1, 3.5.2.

3.4.2. Timing

Main timing for the curve portion of the board is accomplished by means of a programmable timing chain consisting of a static RAM with counters that connect to the RAM's address lines. The eight signals from the programmable timing chain are RASTER X-Y, RETRACE X-Y, MIDPT, two curve BLANK signals, and three color shutter control signals. Refer to Figure 3-7 and Figure 3-8. At start-up the programmable timing chain is loaded from the 68000 and then verified. The timing chain may be modified while the unit is running, to modify the blank signals for screen formatting. While the timing chain is being programmed the display is turned OFF. The programmable timing chain operates at 25 kHz, which provides for a signal resolution of 40 μ s.

The timing chain is split into two four-bit registers, each of which are delayed by 20 μ s. By ORing the two signals, a resolution of 20 μ s is available on the curve blank signal. Timing for the dynamic main curve memory is at a 2 MHz rate. Words going to the DAC are strobed at that rate. The 40 MHz clock is used for the memory control timing. Two interrupts are generated from the curve board. Interrupt 4 is generated from the video timing signal, V SYNC. Interrupt 5 is generated by RETRACE X-Y from the programmable timing chain.

3.4.3. Blanking Circuit

The blanking circuit has two outputs. The first, BLANKING, is a 40 MHz blanking signal used to blank the CRT. This signal is derived from the pixel information

generated on the Display Processor Board during raster time, and is derived from the curve blank signal during curve time. The blanking signal during curve time may be a signal from the programmable timing chain, i.e. to blank the parameter boxes, or may be from the dynamic RAM data when it is equal to all 1's to form a blanking bar for the fixed display mode.

The second signal on the blanking circuit is the intensity signal, Z, which controls the brightness of the CRT. Intensity comes from an 8 bit DAC which is driven by a 4 byte memory. The 4 bytes are used for raster intensity, right hand curve intensity, left hand curve intensity, and the intensity bit. The intensity bit is the twelfth data bit of the dynamic RAM curve memory, and is used to intensify individual pixels of the curve waveform.

Blanking signals from the Curve Board drive circuitry on the Z-Amp Board, which controls the intensity of the electron stream in the CRT. Refer to Section 3.6.2.

3.4.4. Registers

Eight registers are decoded by the curve portion of the board.

- Registers 0 and 1, J62 and J73: are sweep start address counters. The last two bits enable the blanking circuit for menus and blank an entire channel.
- Register 2, J74: controls which of the 3 horizontal ramp generators are used, and controls the wrap around of the sweep start counters.
- Register 3, J34 and J46: loads intensity registers.
- Register 4, J76: clears interrupts 4 and 5.
- Register 5, J63: controls loading of the programmable timing chain; con-

trols output of alarm, pace, and sync output signals, and enables the midpoint loading of the sweep counters for split screen displays.

- Register 6, J58: interrupts the 8344
- Register 7, J96: loads the data into the programmable timing chain.

3.4.5. Curve Board Display Signal Calibration

The display is a dual screen format, raster and XYZ. Since the raster display provides reference lines to the XYZ waveforms, trim pots on the curve board adjust the relative alignment of the curves to the raster screen. Refer to Chapter 7, Calibration/Adjustment, for detailed calibration procedures.

3.4.6. Network Controller

The network controller 8344, J48, has its own ROM and RAM -- 8 kBytes of ROM and 2 kBytes of RAM for communication with SIRENET. An additional 2 Kbyte RAM is used to communicate between the 8344 and the system BUS. The RAM has an ownership bit which allows either the 8344 or the system to gain access to the RAM. The ownership bit is controlled through interrupts. The 8344 has an SDLC serial communications link that runs at 2 Mbps. The clock and data are combined with a Manchester encoder to reduce the number of wires for communication to one differential pair. The Manchester decoder runs at 40 MHz. The 8344 has a timeout alarm (watch dog timer) which sets the audible alarm. This signal is used when the 8344 decides that the main processor 68000 is no longer communicating with the 8344. The timing for the BUS cycles that are used for the shared RAM comes from the timing of the curve portion of the board. The 8344 has its own crystal operating at 12 MHz. There are two SDL connectors on the board. The first connector, X3, contains the differential COMM link lines

as well as a bed number and sync line. The second SDL connector, X4, contains the alarm and pace sync-in, and duplicates the sync-out line from X3.

3.5. Deflection Board

Refer to the block diagram in Figure 3-10, and schematics B-2.6 and B-2.7 in Appendix B.

Control of the X and Y deflection amplifiers originates on the Curve Board. The +/- horizontal and vertical signals from the curve board are conducted by coax wires to the horizontal and vertical amplifiers on the Deflection Board. See Section 3.4.1.

3.5.1. Horizontal Deflection - 1280 Monochrome Monitors

In the 1280 monochrome monitor, the +/- horizontal signals are applied to differential amplifier J6. The output and also the yoke are referenced to +5 V_{DC}. The output from J6 is amplified by J8 and applied to the high current buffers, V46 and V48, which drive the horizontal yoke to +/- 19 volts.

Overall horizontal linearity correction is provided by R31 and J5 circuitry, which is in series with the yoke and high current buffers, and linearity centering by R53. Thermistor R39 compensates for temperature variations inside the monitor to keep picture size constant.

R34, in series with the signal input to J8, controls horizontal gain. R72 provides for adjustment of horizontal position by controlling the average $\pm V_{DC}$ drive level on the signal input to J8.

The voltage and high power buffer amplifiers in the 1280 form a system that saves power. High power buffer V48 normally operates on a positive voltage that can vary from +19 volts to ground. If current sensing circuits sense a negative voltage swing, buffer amplifier V49 is switched on

System SIRECUST 1280/1281 Bedside Monitor - Service Manual

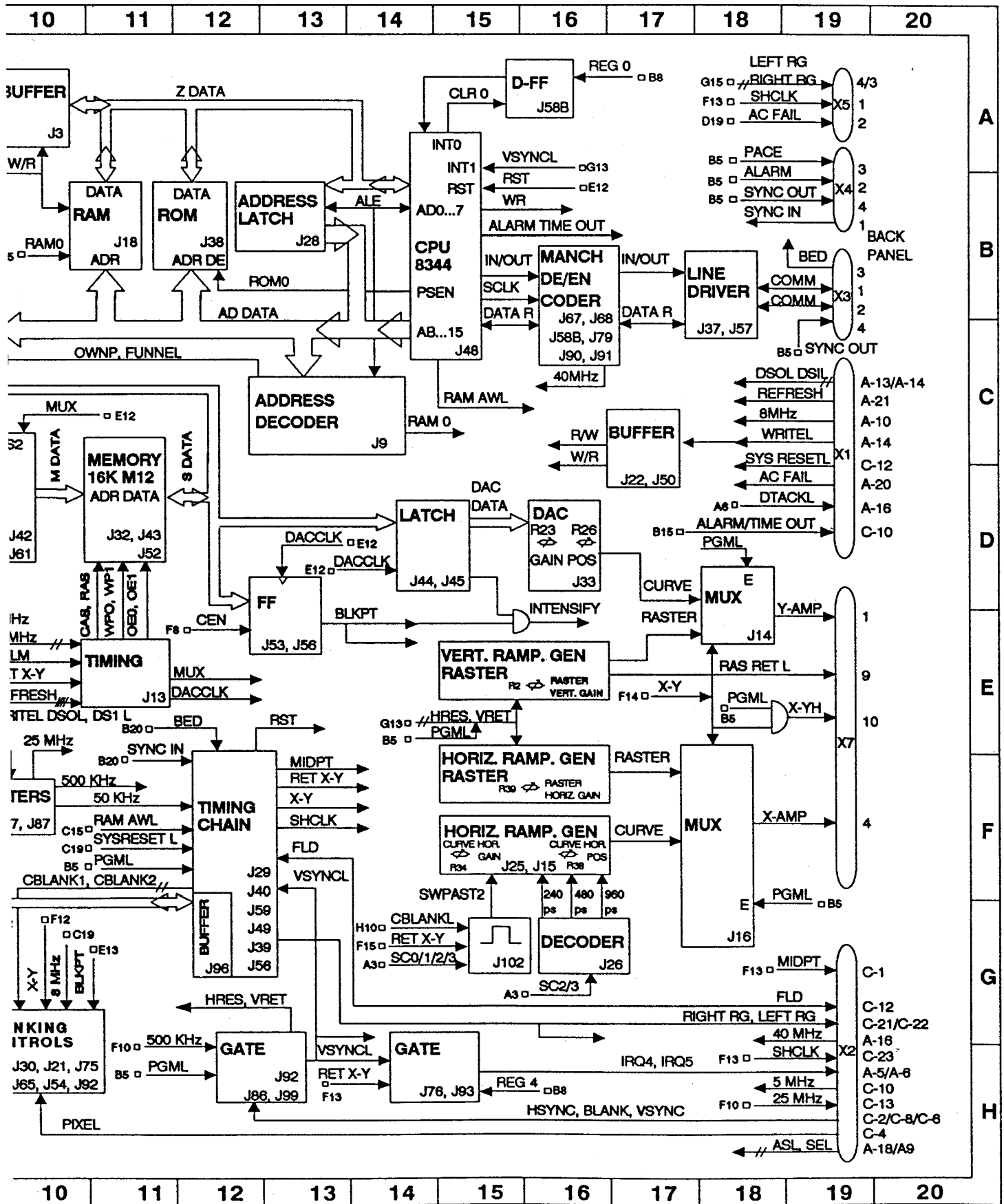

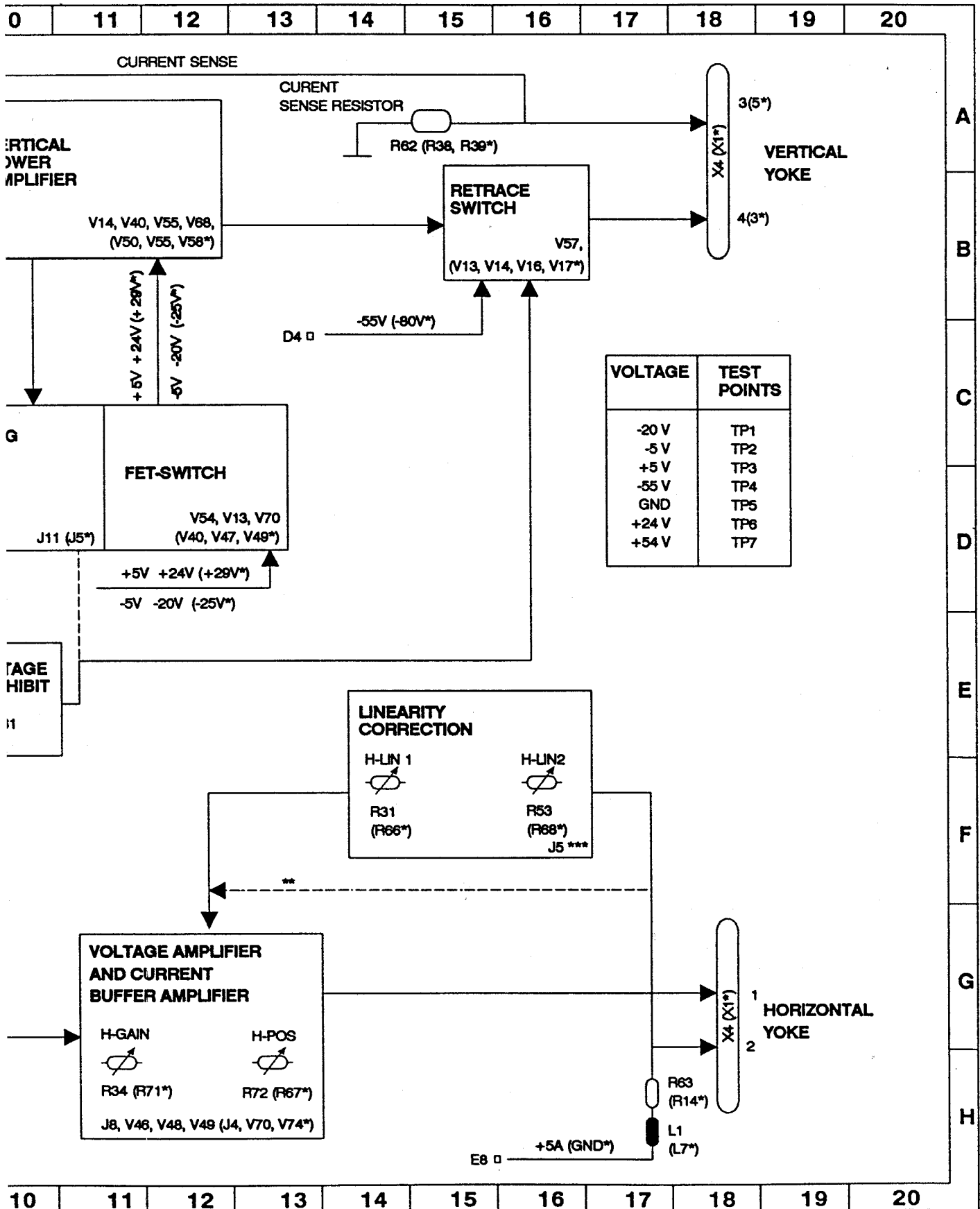

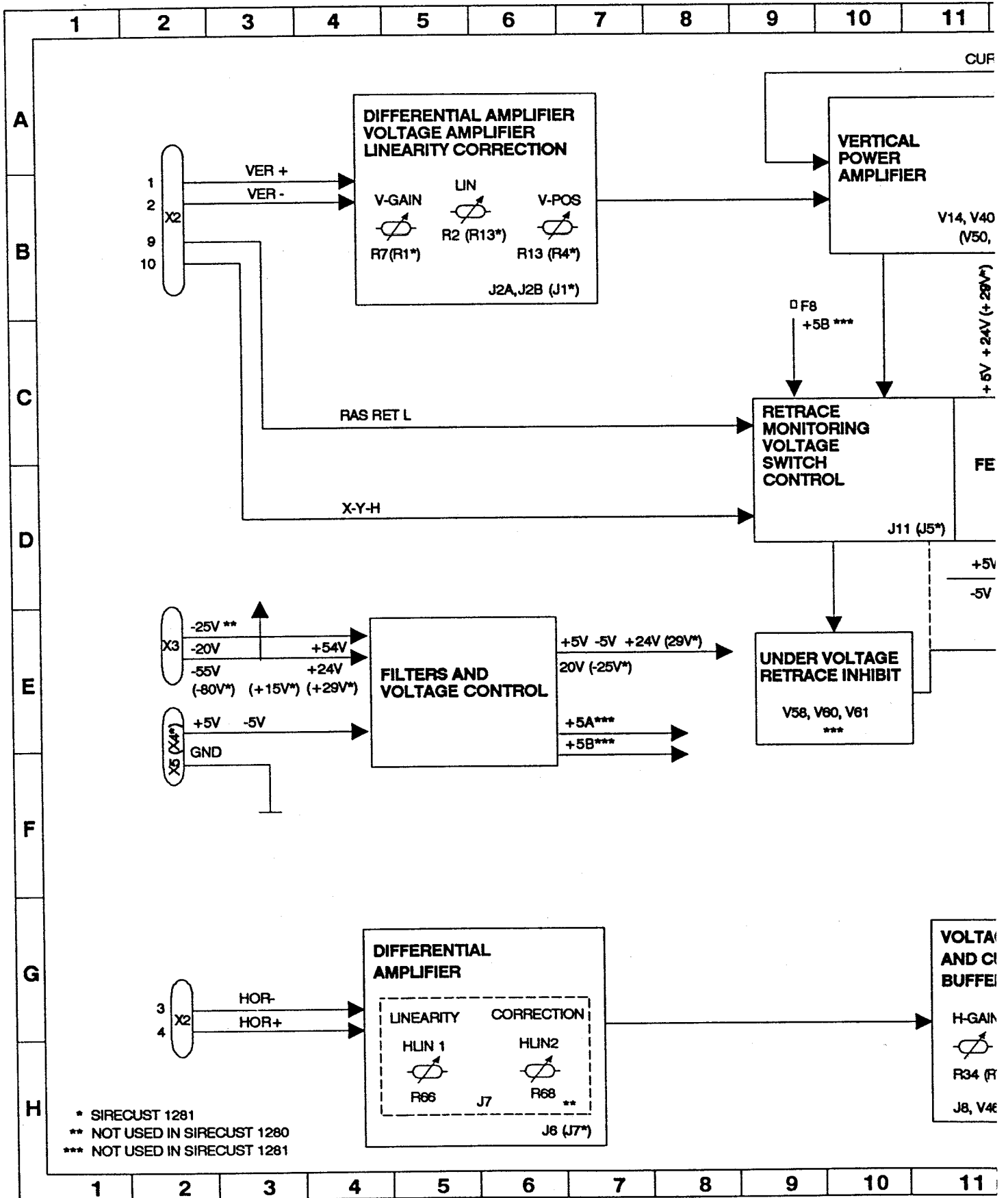

Figure 3-10. Deflection Board Block Diagram

allowing the full negative swing to -19 volts. This saves power since the -19 volts is used only when needed.

3.5.2. Horizontal Deflection - 1281 Color Monitors

In the 1281 color monitor, the +/- horizontal signals are applied to differential amplifier J7. The yoke and J7 are both referenced to 0 V_{DC}. The output from J7 is applied to J8 which regulates output by comparing yoke current to input voltage using current sampling resistor R74. J8 drives the high current buffer circuit, V70 and V74. XY-H controls V65, which switches the supply voltage to V70 between +29 V_{DC} and +40 V_{DC} depending on whether the monitor is in raster mode or in curve mode.

Linearity correction is managed by R66, R68 and J9, which provide feedback to the differential signal input at pin 6 of J7. R71 in series with the signal input to J8 controls horizontal gain. R67 provides for adjustment of horizontal position by controlling the average $\pm V_{DC}$ drive level on the signal input to J8.

3.5.3. Vertical Deflection - 1280 Monochrome Monitors

In the 1280 monochrome monitor, vertical deflection amplifier circuitry, J2A and J2B, amplifies the +/- vertical signals from the curve board. Through current gain amplifiers, the output signal drives the high current amplifiers V14, V40, V55 and V68, and applies a ± 20 V signal at up to 8 amps to the vertical deflection yoke. Logic signal RAS-RET L from the curve board drives 3.5 μ s monostable multi-vibrator circuitry which initiates retrace during raster mode through retrace FET switch V57.

The vertical amplifier acts as a linear amplifier during the curve mode and as a switched linear amplifier during raster mode. During raster retrace, the linear amplifier is disconnected from its +24 V_{DC}

supply by FET switch V13, and the yoke is connected directly to the -54 V_{DC} supply line by the FET switch, V57.

The yoke is connected to the -54 V_{DC} line for a time determined by the 3.5 μ s monostable circuit, which provides time for the yoke current to build up to the required 10 A. After the monostable timeout period the switched supplies to the linear amplifier are reconnected and the amplifier operates in a normal linear mode.

The voltage is controlled by the amplifier's feedback circuitry so that the current in the yoke will be directly proportional to the yoke analog input from the curve board. Current in the yoke is compared to a ramp waveform produced by the curve board to generate the raster. An error amplifier amplifies the error and corrects the voltage applied to the yoke so that the two remain equal. The correction signal is applied to the analog input from the curve board after the input enters the board, and is then applied to the error amplifier.

Linearity correction is managed by R2 and J1, which provide feedback to the differential signal input at pin 6 of J2B. R7 in series with the signal input to J2B controls vertical gain. R13 provides for adjustment of vertical position by controlling the average $\pm V_{DC}$ drive level on the signal input to J2B.

3.5.4. Vertical Deflection - 1281 Color Monitors

In the 1281 color monitor, vertical deflection amplifier J1 amplifies the +/- vertical signals from the curve board. Through current gain amplifiers, the output signal drives the high current amplifiers V50, V55, and V58, which supply the vertical deflection current to the yoke. Logic signal RAS-RET L from the curve board drives is gated through FET switches V7 and V8 to initiate retrace during raster mode through retrace FET switches V16 and V17.

The vertical amplifier acts as a linear amplifier during the curve mode and as a switched linear amplifier during raster mode. During raster retrace, FET switch V17 disconnects the linear amplifier from its +29 volt supply and FET switch V16 connects the yoke directly to the -80 volt supply.

The voltage is controlled by the amplifier's feedback circuitry so that the current in the yoke will be directly proportional to the yoke analog input from the curve board. Current in the yoke is compared by V24 to a ramp waveform produced by the curve board to generate the raster. An error amplifier amplifies the error and corrects the voltage applied to the yoke so that the two remain equal. The correction signal is applied to the analog input from the curve board after the input enters the board, and is then applied to the error amplifier.

Linearity correction is managed by the feedback circuit, R13 and J3, which correct the differential signal input at pin 5 of J1. R1 in series with the signal output from J1 controls vertical gain by limiting the current drive to current amplifier V24. R4 provides for adjustment of vertical position by controlling the bias current on current amplifier V24.

3.5.5. Power-saving Circuitry

The power output stages of the vertical amplifiers are powered from $\pm 5 V_{DC}$ or from the +24(mono)/+29(color) and -20 V_{DC} depending on the required output voltage of the amplifier to the yoke. When the output of the amplifier is less than +5 volts current to the yoke is being supplied by the +5 V_{DC} power supply. When the output voltage of the amplifier is required to be higher than 5 volts the output transistor saturates and draws more base current. This activates an FET switch which connects +24/+29 V_{DC} to the current amplifier. In this way the base-emitter voltage across the output transistors are normally kept lower than

+24/+29 V_{DC} , resulting in lower power dissipation by the amplifier. The minus supplies of the amplifier work similarly, switching between -5 V_{DC} and -20 V_{DC} as required by the output voltage of the amplifier to the yoke.

An additional power saving switch is used during the raster mode. Since the output voltage of the amplifier in raster mode is never required to be less than +5 volts and never greater than +20 volts, the amplifier is switched between the +24/+29 V_{DC} and +5 V_{DC} supply lines instead of between the +24/+29 V_{DC} and -20 V_{DC} supplies. A digital signal originating on the curve board, XY-H, controls switching. The signal goes LOW to enter the raster mode. Also during raster mode an FET switch turns the +5 V_{DC} supply to the amplifier OFF.

N Channel FETs are used throughout the amplifier for power switching. Since they require a more positive voltage on their gate than on their source to turn ON, a voltage higher than the +24/+29 V_{DC} supply is required to operate the control circuit for the +24/+29 V_{DC} FET supply switch. This is provided by the +54 V_{DC} supply and a floating 10 volt regulator that maintains a voltage that is always 10 volts higher than the switched +24/+29 V_{DC} supply line.

The FETs that switch the +24/+29 V_{DC} supply, connect the yoke, and switch the yoke to the -54 V_{DC} supply, are driven by buffer amplifiers that provide a turn ON delay to each of the FETs. This prevents both FETS from overlapping, reducing reliability, and drawing more power.

3.6. Z-Amp Board

Refer to the block diagram in Figure 3-11 and schematic diagram in Appendix B.

3.6.1. High-voltage Power Supply

The high-voltage power supply circuitry supplies 15 kV at 1.5 mA to the CRT

anode, $+600 V_{DC}$ to the accelerator grid, $-55 V_{DC}$ ($-80 V_{DC}$ on color monitors) to $+400 V_{DC}$ to the focus grid (adjusted by R40), $-300 V_{DC}$ to the intensity circuit, and $+54 V_{DC}$ ($+78 V_{DC}$ on color monitors, used in intensity circuit and regulated by V34 to $+54 V_{DC}$ for the other circuits on the board). It is powered from the $+15 V_{DC}$ and $-54 V_{DC}$ supplies ($+15 V_{DC}$ and $-80 V_{DC}$ supplies on color monitors) on the main power supply board.

The high-voltage supply is a pulse width modulated flyback switching power supply. It is synchronized to the display processor board by a 25 kHz clock.

The 15 kV anode supply is developed in a times-three capacity multiplier, A1. The input to the multiplier comes from a high voltage flyback transformer, T1, that develops $5 kV_{PP}$. $+15 V_{DC}$ is applied to the primary of the flyback transformer, T1, for a time determined by the pulse width modulator circuit. The time, $0 \mu s \leq \text{time} \leq 20 \mu s$, depends on the desired output voltage. At the end of that time the FET switch that applied the voltage, V36, turns OFF. The voltage across the primary of the transformer flies up to a positive voltage of approximately 90 volts. At the same time the output voltage on the secondary of the transformer flies up to approximately $4,000 V_{DC}$. The extra 1 kV required on the output of the transformer to obtain $5 kV_{PP}$ is obtained when the FET switch at the transformer is connected.

The pulse width modulator signal is derived from comparator J6 which compares a 25 kHz sawtooth waveform to a DC error voltage. As the DC voltage varies, the width of the output pulse from the comparator changes.

An error voltage is obtained by comparing a divided-down voltage from the multiplier output to an on-board 5 volt reference. The output of the multiplier is adjusted by potentiometer R63.

A 15 volt under-voltage detector circuit, V24, R36, R51, and V17, disables the power supply until the $+15$ volt supply is >13 V. This prevents the circuit from latching up and drawing excessive current from the $+15$ V supply.

The under-voltage detect circuit also controls slow turn-ON circuitry which causes the $+5 V_{DC}$ reference to slowly ramp up to 5 volts after the power supply reaches operating voltage levels. This prevents excessive current from being drawn when power is first applied.

The $+54 V_{DC}$ supply voltage is developed by a square-wave generator, V26 and V25, which level shifts and half-wave rectifies a -54 volt (-80 volt in color monitors) square-wave voltage to produce $+54 V_{DC}$ ($+78 V_{DC}$ in color monitors). The square-wave is synchronized to the 25 kHz clock from the curve board.

$300 V_{AC}$ from a tap on the secondary of the high voltage flyback transformer, T1, is half-wave rectified and filtered to produce the $-300 V_{DC}$ supply voltage.

3.6.2. Z-Amp (Intensity)

The intensity amplifier is a linear amplifier having a band width of approximately 500 kHz. The 0 to -5 volt input signal from the curve board (see Section 3.4.3), VIDEO IN, is amplified by V10, V12, and V13 to produce a 2 to 50 volt output signal, E2, applied to the cathode of the CRT. 0 volts at the input to V10 produces $+2 V_{DC}$ at the cathode for the brightest intensity. High voltage arc protection is provided by the spark gap, F2, to prevent internal arcing in the CRT from causing damage to the amplifier transistors.

3.6.3. Blanking Circuit

A blanking circuit, J1 and J2, which drive C-MOS FETs V6 and V14, produces a $55 V_{PP}$ signal to the control grid of the CRT from a TTL input from the curve board. A

"0" on the input causes the output signal to be at its lowest state and a "1" causes the output signal to be at its highest state. The actual DC level control current output is determined by the intensity potentiometer, R3, which can shift the output voltage over a 100 volt range in order to adjust the overall intensity on the screen. This amplifier typically passes 25ns pixel pulses with rise and fall times of 10ns. It uses V6 and V14 to produce fast rise time output pulses. Retrace timing is adjusted by R1 and R2.

Intensity adjustment is done by shifting the 0 to +50 volt pulse output from the C-MOS FETS to a lower voltage. First a highly stable +100 V_{DC} reference is established using a zener diode which is biased by the -300 V_{DC} supply. The desired voltage level shift, obtained from a resistive voltage divider across the +100 V_{DC} reference voltage, creates the desired intensity. Spark gap F1 provides high voltage arc protection for the circuit.

3.7. Operator Interface Board

The Operator Interface Board is the primary interface and control element for the TouchScreen and the Color Shutter in 1281 monitors. See the block diagram in Figure 3-12 and schematic diagram in Appendix B.

Also, a light-sensitive diode monitors ambient brightness and the board sends a signal to the monitor CPU to vary the CRT brightness. See Section 3.7.3.

3.7.1. Microcomputer

The Operator Interface Board microcomputer (J9) is a MC68705R3, which has 3776 bytes of EPROM, four 8-line ports (one is input only and three are I/O, each line determined individually), and 112 bytes of RAM. It communicates with the Display Processor Board through its interrupt input (RX IN), PA0 (TX OUT), and PB2 (CTS), and with operator input

devices (TouchScreen) and the ambient light sensor through its various ports. Some boards (A292) are equipped with a watchdog timer, J12, that monitors pin 14 of the 68705 microcomputer and resets the microcomputer if no pulses exist at J14 for a period of one minute.

3.7.2. TouchScreen

The TouchScreen is the primary user input device, and interfaces with the Operator Interface Board through connector X2. A +5 V_{DC} regulated reference voltage is generated on the board by J8 and the +15 V_{DC} from the power supply for use with the TouchScreen and the ambient light sensor and for their A/D conversion. A 1.25 V_{DC} TouchScreen drive voltage is derived from a resistive voltage divider across the +5 V_{DC}. The TouchScreen has very low resistance and can draw current of more than 100 mA. Therefore, an Op Amp-Transistor high current driver is used in conjunction with the 1.25 V_{DC} reference voltage.

Since the +5 V_{DC} reference is used both in the sensor circuitry and as VRH (the positive reference for the A/D converter in the microcomputer), the system is exceptionally stable.

The TouchScreen consists of two conducting membranes, one for up-down (Y) and one for left-right (X). See Figure 3-13. The two membranes are separated by tiny silicone dots. Each membrane has a low resistance. A pair of power MOSFETs alternately connect one end of each membrane to ground and the other end to 1.25 V_{DC}. In this application power MOSFETs are used for their low "ON" resistance and not for their power handling capability.

With no pressure on the TouchScreen, the X to Y signal across the two membranes is high. This keeps the X switches ON and the Y switches OFF. The X signal to amplifier J3 is near ground and the voltage to the microprocessor's A/D

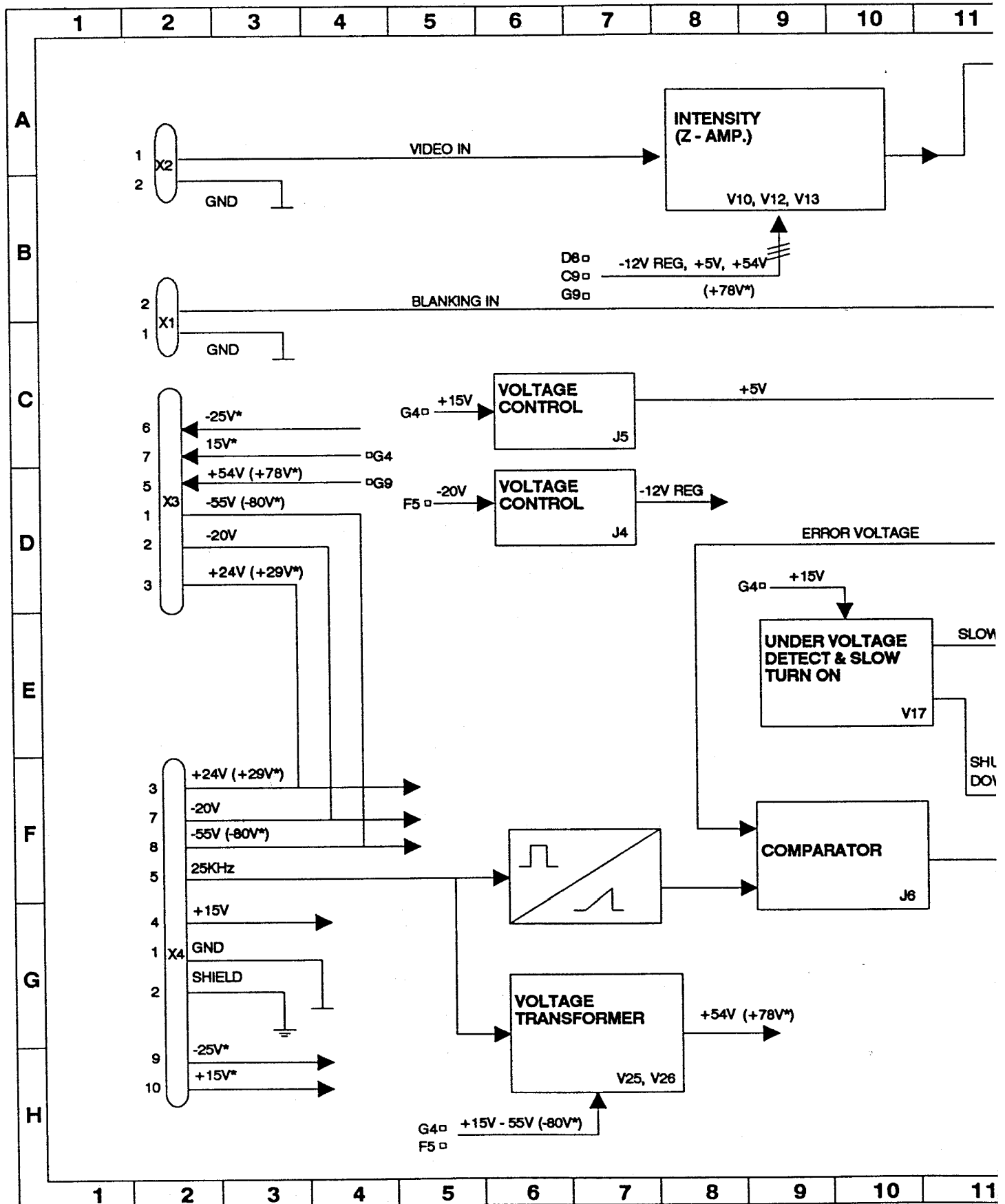
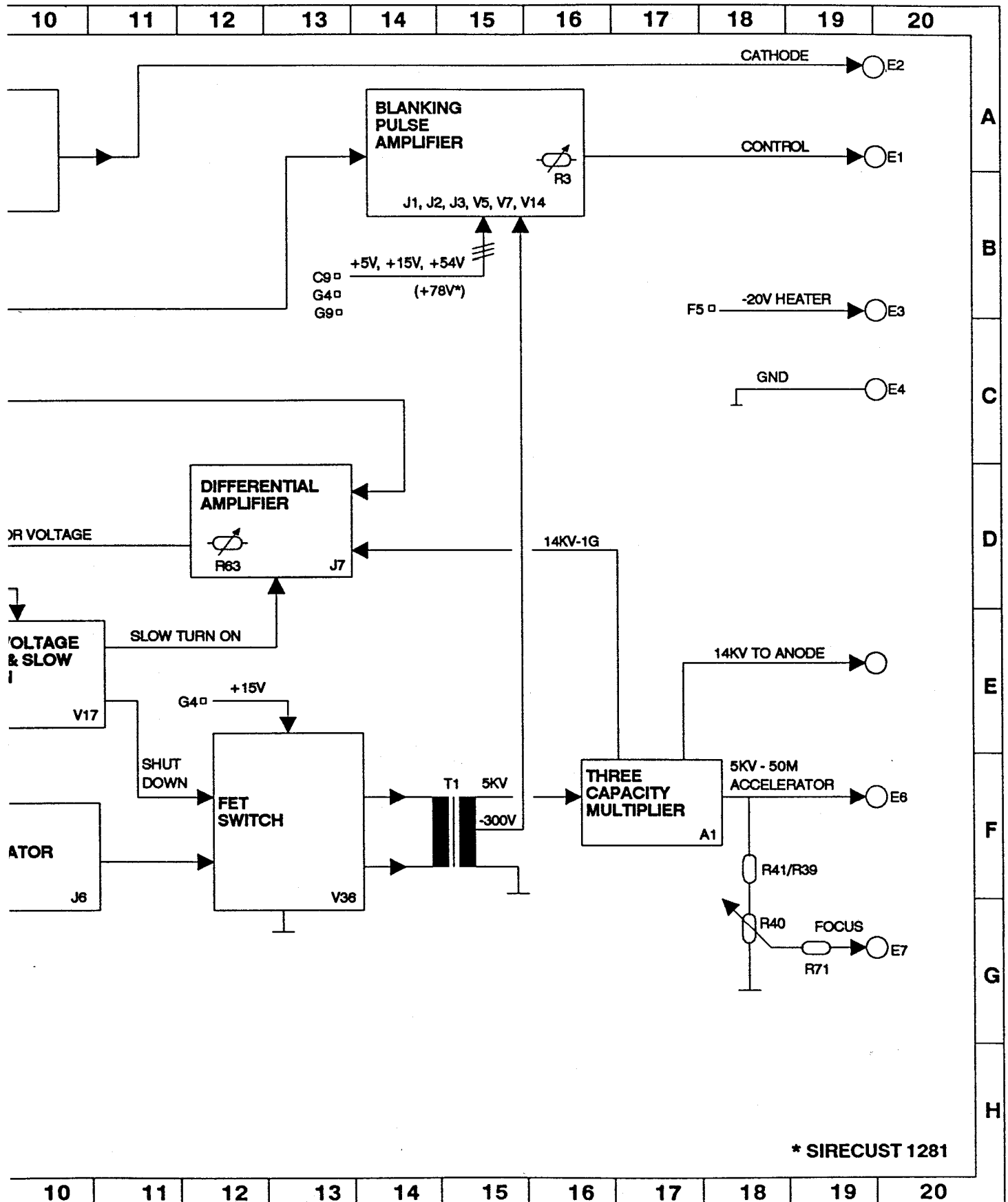
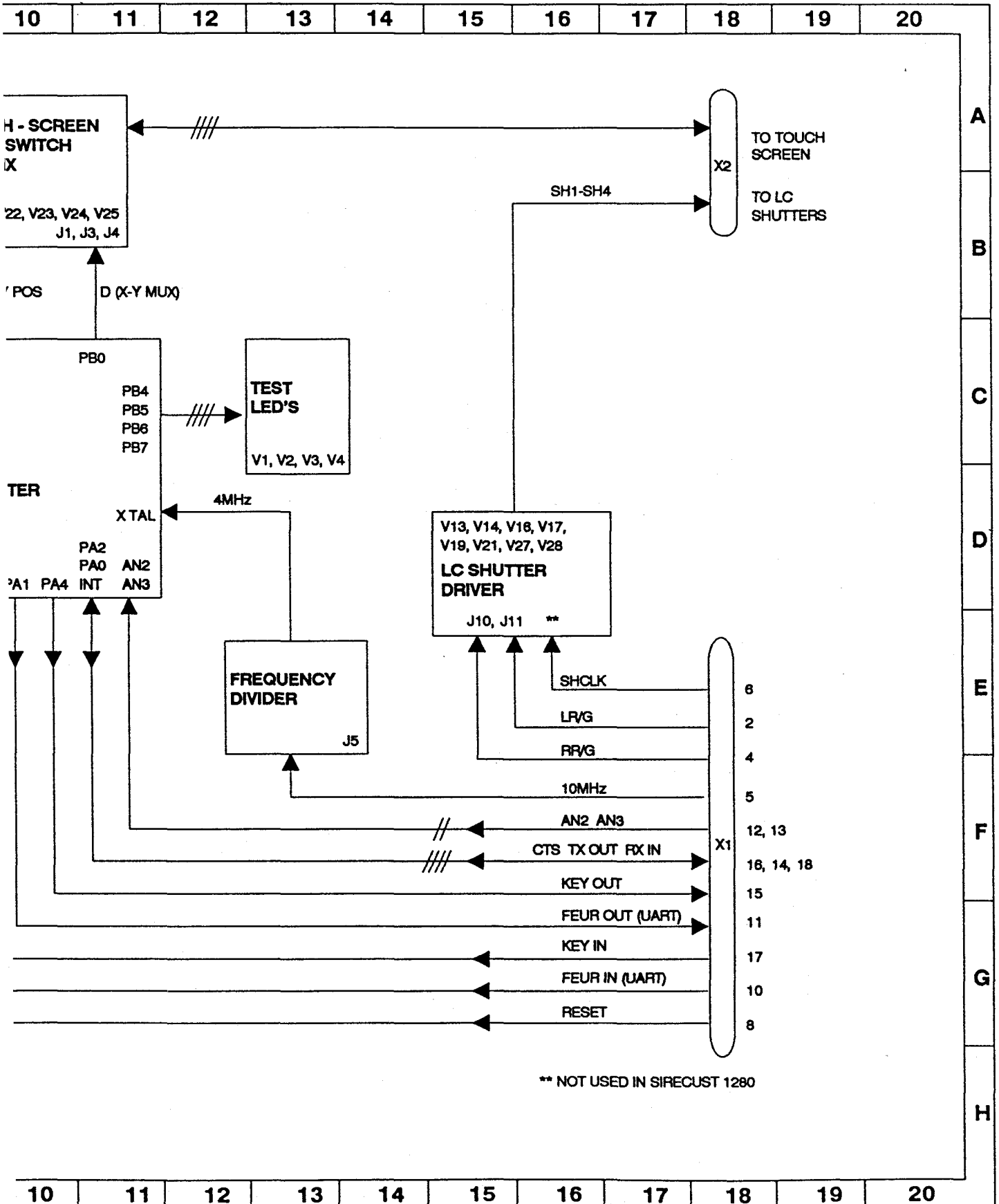

Figure 3-11. Z-amplifier Board Block Diagram

System SIRECUST 1280/1281 Bedside Monitor - Service Manual



* SIRECUST 1281



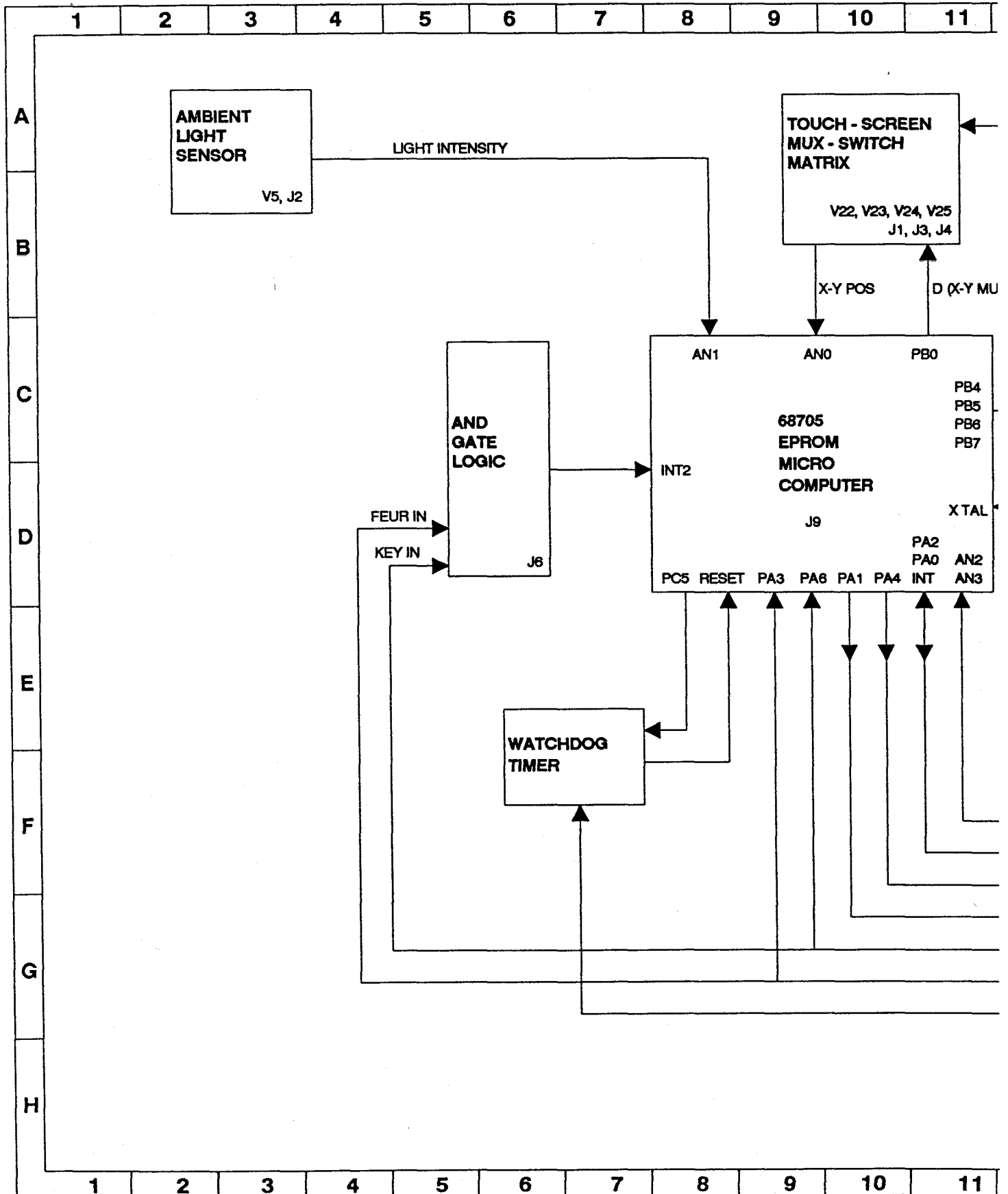

Figure 3-12. Operator Interface Board Block Diagram

System SIRECUST 1280/1281 Bedside Monitor - Service Manual

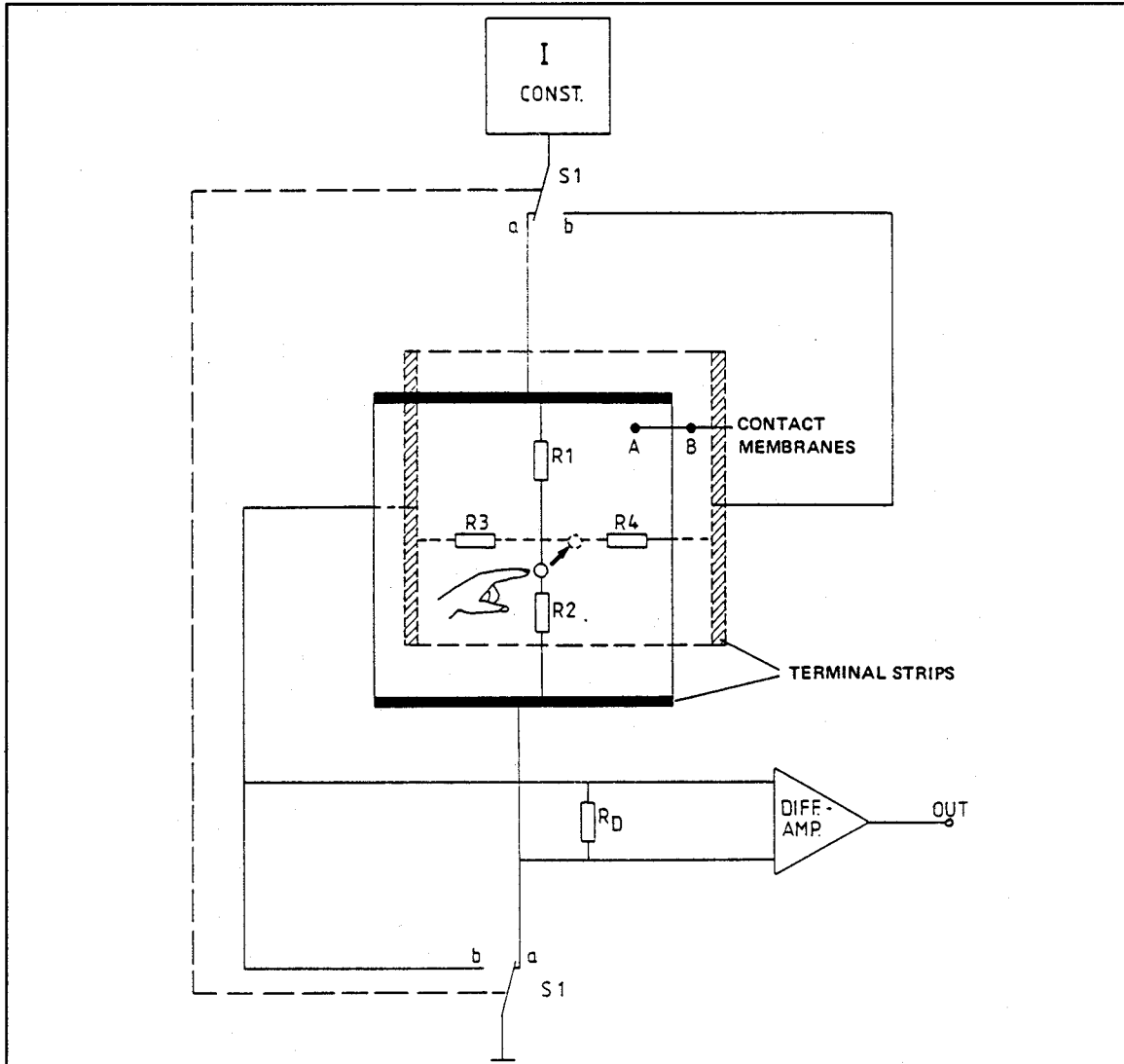

Figure 3-13. TouchScreen Circuit Function

input (Pin 24) is near V_{Ref} . Finger pressure applied to any location of the TouchScreen causes the two membranes to connect at that location. The X signal to J3 goes above ground, and the A/D input goes below V_{Ref} and is digitized. The X-Y control signal then goes LOW. The X switches are opened and the Y switches closed. The Y signal goes to the A/D input and is digitized.

3.7.3. Ambient Brightness Monitor

For optimum viewing the display brightness automatically adjusts to

ambient brightness. A cadmium sulfide cell, mounted on this board, receives room light through a window on the front panel. The cell's resistance varies with incident light. As the light level increases, the resistance decreases and the voltage input to the A/D input at J9 Pin 23 decreases. As the light level decreases the resistance increases and the voltage increases. The digitized version of the A/D voltage is sent, via the serial port, to the Display Processor Board which controls the CRT brightness through the Curve Board.

System SIRECUST 1280/1281 Bedside Monitor - Service Manual

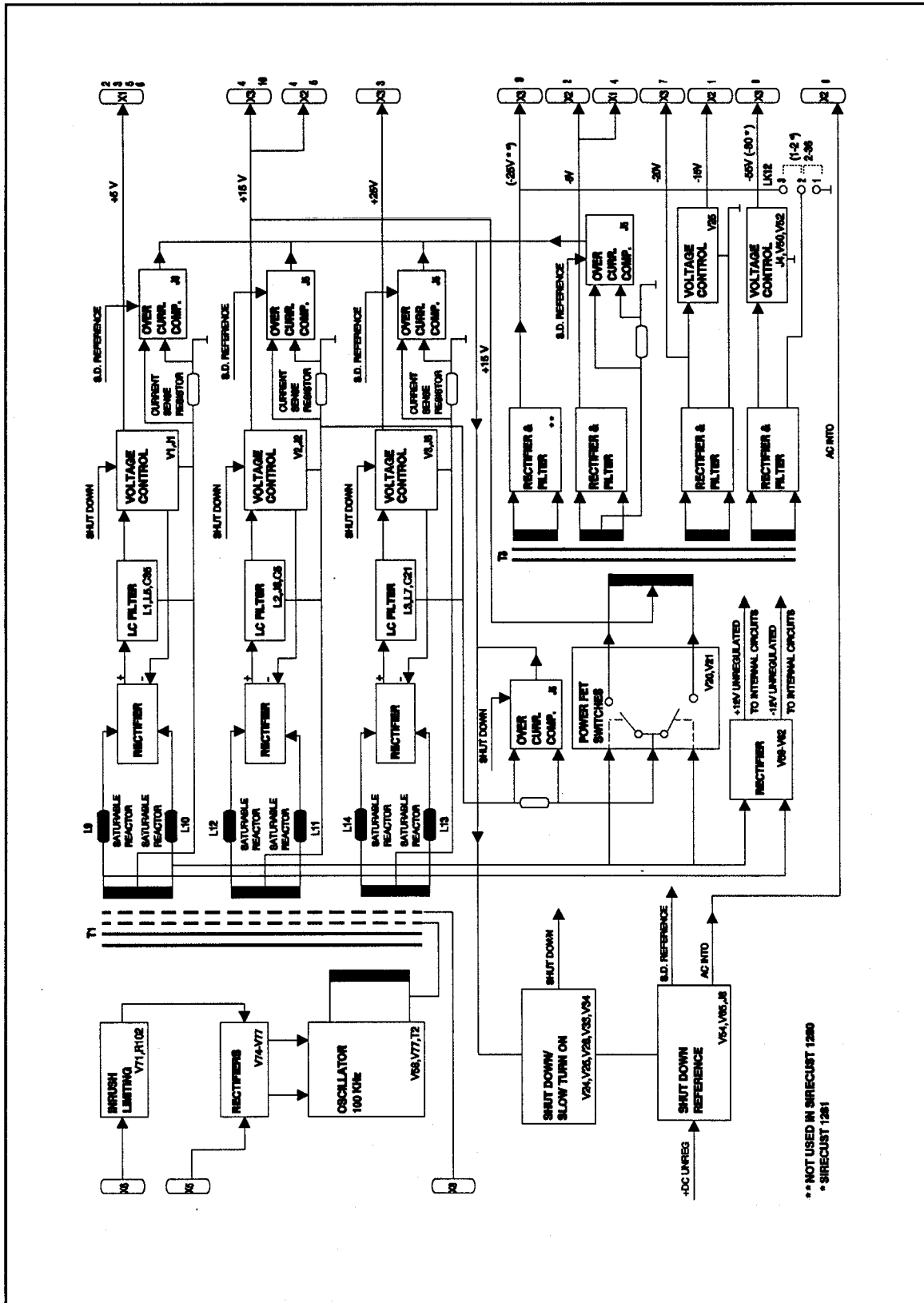

Figure 3-14. Power Supply - Block Diagram

3.8. Power Supply

The power supply in SIRECUST 1280/1281 monitors can be set up to operate on input voltages of either 90 V_{AC} to 132 V_{AC}, or 180 V_{AC} to 264 V_{AC}, by means of a plug on connector X4 on the power supply PC board. See Figure 3-15. With the plug in place, the power supply is configured for 90 V_{AC} to 132 V_{AC} operation. The plug configures the input rectifiers as a half-wave voltage doubler. Removing the plug or offsetting its position on X4 sets the supply for 180 V_{AC} to 264 V_{AC} operation, and configures the rectifiers as a full-wave bridge.

The block diagram of Figure 3-14 is a composite of both A140 (SIRECUST 1280) and A280 (SIRECUST 1281) power supplies. Voltages that are unique to either power supply are identified on the diagram. Refer to Appendix B for a schematic of each individual supply.

3.8.1. Main Inverter

The main inverter (oscillator) and transformer T1 are used to develop the +DC power supply output voltages. Table 3-1 is a listing of the voltages for each supply. The ac output from T1 used to develop the +5 V_{DC} output voltage, transformer connections E5 and E6, is also used to control the auxiliary inverter and to develop unregulated ± 12 V_{DC} for internal use by power supply circuits.

The ± 155 V_{DC} output voltages from input rectifiers V74, V75, V76, and V77 are converted to a 310 V_{P-P} 100 kHz square wave by a half-bridge blocking oscillator. The 310 V_{P-P} is applied to the main step-down transformer, T1. Output voltages from the transformer are individually magnetically regulated by saturable core reactors, rectified, and L-C filtered to obtain the required +5 V_{DC}, +15 V_{DC}, and +25 V_{DC} output voltages. The +5 V_{DC}

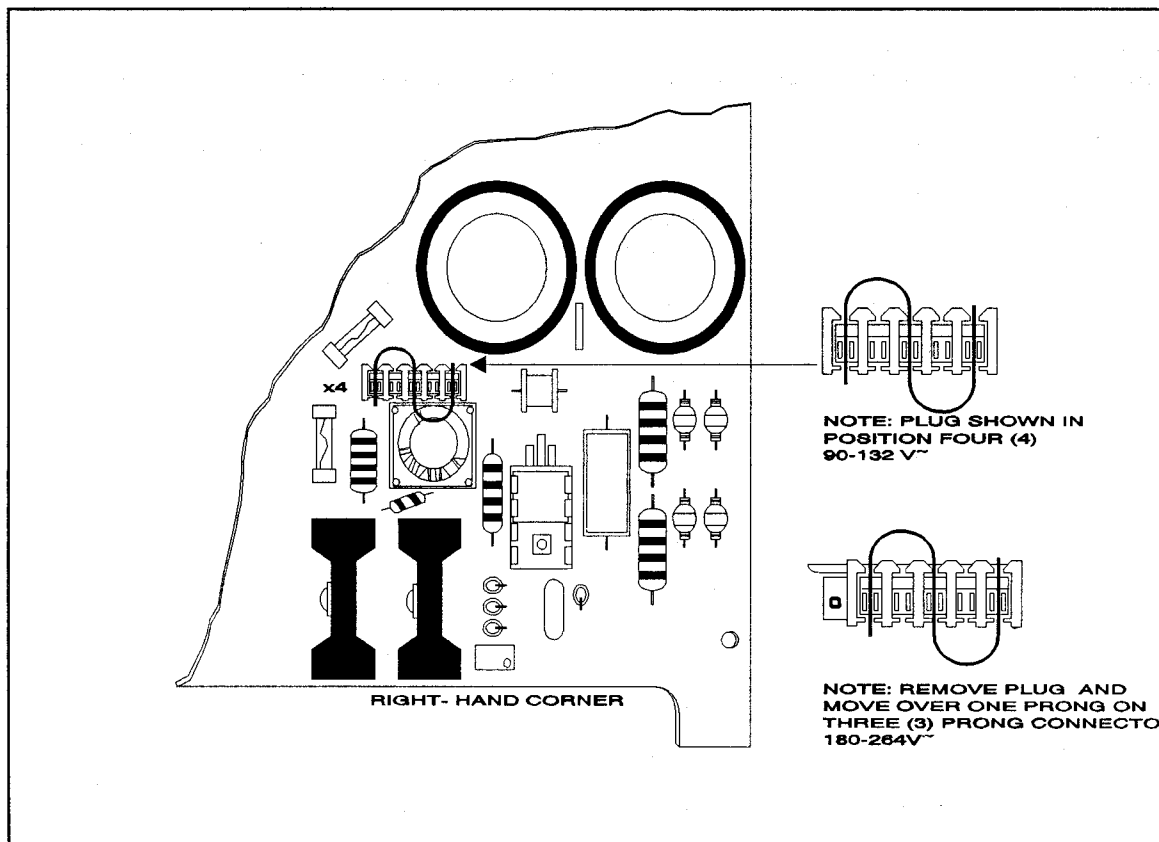

Figure 3-15. Positioning X4

output voltage can be adjusted using potentiometer R3, and the +15 V_{DC} output voltage by potentiometer R14. The +15 V_{DC} is also used as the voltage source for the auxiliary inverter described in Section 3.8.2.

A "slow turn-ON" circuit allows all DC output voltages to slowly build up to their nominal values. V71 and R102 form a current limiting circuit which controls the charge rate of C41 and C42 at turn-ON. V33 serves a dual function of either holding all voltages OFF or allowing them all to rise slowly through feedback to the magnetic regulators.

3.8.2. Auxiliary Inverter

The auxiliary inverter and transformer T3 are controlled by the T1 ac output used to produce the +5 V_{DC}. This circuit develops the -5 V_{DC}, -15 V_{DC} and -20 V_{DC} output voltages. In SIRECUST 1280 monitors the auxiliary inverter circuitry is

also used to produce a -55 V_{DC} output, and in SIRECUST 1281 monitors it is used to produce output voltages of -25 V_{DC} and -80 V_{DC}.

Under control of the ac voltage from T1, power FET switches convert +15 V_{DC} from the main inverter output circuitry into a 30 V_{R.P.} 100 kHz square wave through the primary winding of T3. The output voltages from T3 are rectified and capacitor filtered. Link 1 references the -60 V_{DC} to either ground or to -25 V_{DC}, to produce -55 V_{DC} or -80 V_{DC}.

All DC output voltage circuits are current limited. Voltages developed across current sensing resistors are monitored by comparators that generate a signal if excessive current is sensed in any output circuit. The signal is amplified and fed back to V33, which switches and latches all voltages OFF until RESET. To RESET the circuits, turn the power supply OFF for approximately 10 seconds and then

Table 3-1. A140/A280 Power Supply Test Points

<u>VOLTAGE</u>	<u>CONNECTOR</u>	<u>CONDUCTOR COLOR</u>	<u>MEASUREMENT DEVICE</u>
GND	X1-1,7 X2-8,9 X3-1,2	BRN, VIO GRY, WHT BRN, RED	DIGITAL VOLTMETER
+ 5V	X1-2,3,5,6	RED, ORN, GRN, BLU	
- 5V	X1-4 X2-2	YEL RED	
+ 15V	X2-4,5 X3-4 X3-10	YEL, GRN YEL BLK (A280, SIRECUST 1281 ONLY)	
- 15V	X2-1	BRN	
+ 25V	X3-3	ORN	
- 25V	X3-9	WHT (A280, SIRECUST 1281 ONLY)	
- 20V	X3-7	VIO	
- 55V	X3-8	GRY (A140, SIRECUST 1280 ONLY)	
- 80V	X3-8	GRY (A280, SIRECUST 1281 ONLY)	

back ON. Except for the -5 V_{DC} output, which has its own current sensor, over-current protection is provided for the -V_{DC} output voltages through a sensor in the +15 V_{DC} supply line to the auxiliary inverter. An overcurrent condition in any of the -V_{DC} supplies causes the sensor to generate a signal to V33.

The ac output from T1 used to control the auxiliary inverter is also used as input to a voltage sensing circuit that generates the signal, AC INTO. The circuit becomes active if the input voltage drops to less than 90V_{AC}/180V_{AC}, and informs the CPU of imminent line failure so that information can be stored and not lost because of power failure. It sends a signal to V34, if the input voltage drops to less than 80V_{AC}/160V_{AC}, to power-down the supply.

3.9. Monitor Display

SIRECUST 1280/1281 monitors incorporate a 12-inch CRT display that provides

up to 8 channels for waveforms or for one EKG waveform and 7 trend channels.

Physiological data waveforms require sharp crisp displays that show the necessary diagnostic features of patients physiological vital signs, and also the capability to display various calculated or derived alphanumeric data.

Two display techniques have been incorporated in SIRECUST 1280/1281 monitors to optimally support these needs with a high fidelity physiological display. Refer to Figure 3-16.

The X-Y-Z display function draws the waveform as a continuous line on the screen.

The raster display function allows the display of any letter, symbol, or graphics at any position on the screen. See Figure 3-17.

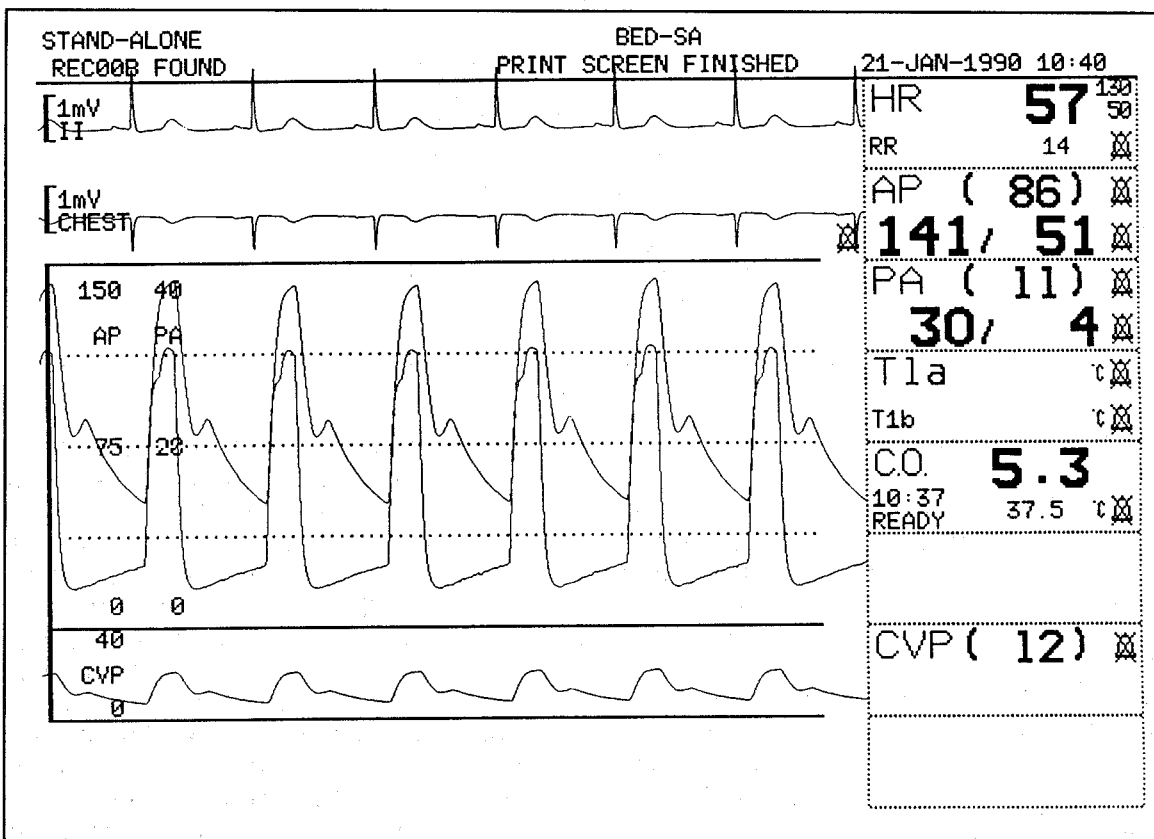

Figure 3-16. Typical Waveform Screen

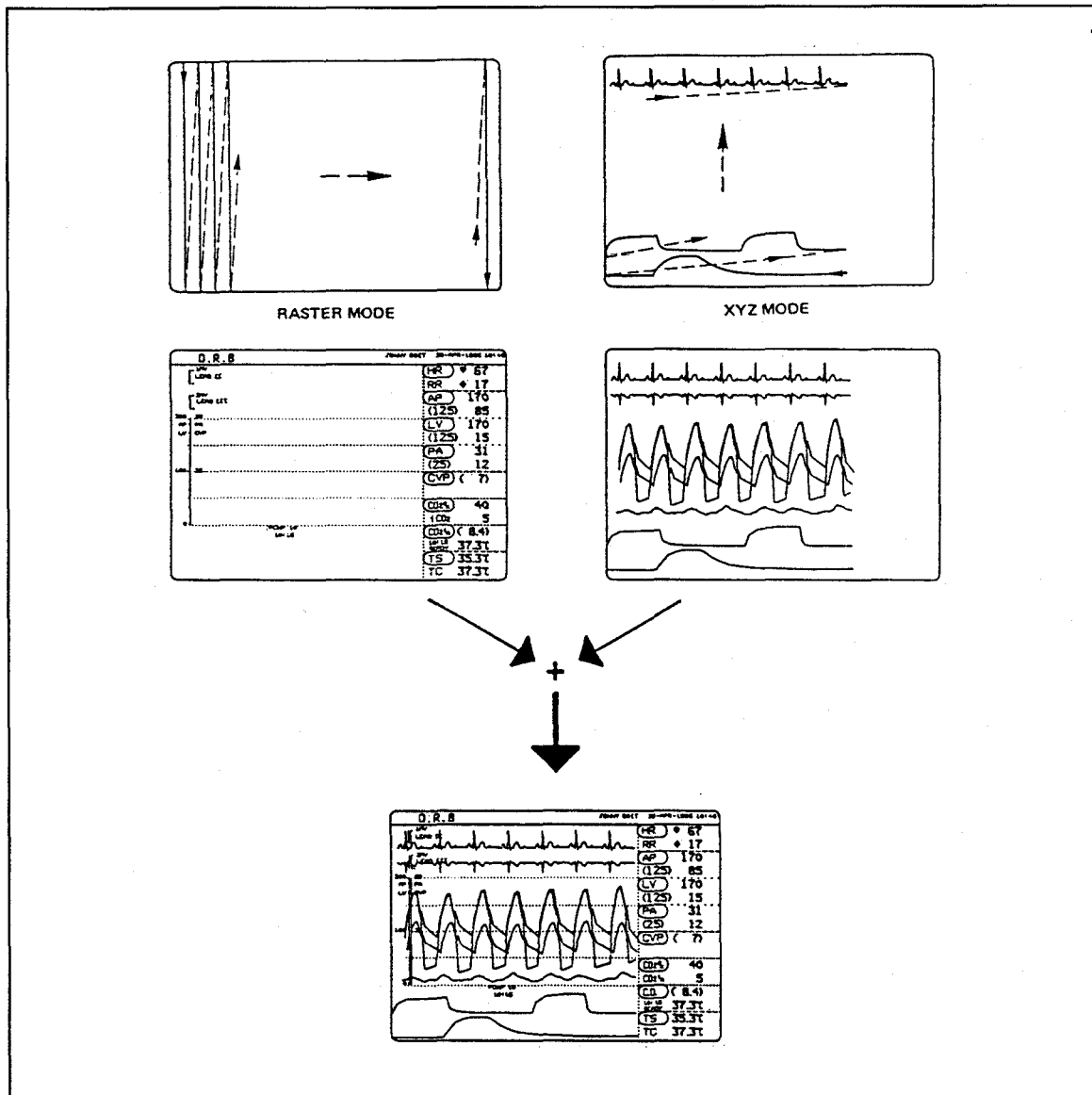

Figure 3-17. Combined XYZ and Raster

3.9.1. Color Shutter

SIRECUST 1281 monitors are equipped with a color shutter installed in front of a monochrome CRT display. A color shutter or LCS (liquid crystal shutter) is a switchable filter which can color the display with two basic colors, red and green, and by alternating the filter during the 50 frame/sec display update, yellow is generated. Because of the speed with which the filter can be switched, individual waveforms and alphanumeric data can be

displayed in color. This technique combines the high resolution display features of a monochrome CRT and color. The color shutter is positioned in front of a monochrome CRT and is used to switch the light from the CRT between green and red. If information is written both green and red, the information will appear yellow. During the color mode the screen needs to be written twice as fast as the black and white mode, since the entire screen must first be written in green and then written in red. For this reason, the

resolution of the raster has been decreased to 480 lines by 320 dots. Figure 3-17 illustrates the relationship between the X-Y-Z and the raster displays in development of the full screen for both monochrome and color screens.

As mentioned above, the 12-inch black and white CRT display assembly shows a combination of X-Y deflection and vertical raster deflection. In the raster mode 600 (480 in color) lines are swept out in 9.6 milliseconds. Then 8 XY curves are traced in 10.4 ms. Thus, in 20 ms one complete raster and 8 curves are displayed, which yields a flickerfree display update rate of 50 frames/sec.

Timing and control signals for the display sub-system (see Figure 3-8) originate on the Curve board. From the Curve board the signals are routed to the Deflection and Z-Amp boards and then to the CRT's deflection yoke.

The color shutter is located behind the TouchScreen on the front panel, and is plugged into the Operator Interface Board at connector X2. The left and right sections of the shutter are enabled separately, as illustrated in the timing diagram of Figure 3-8.

With no voltage applied to a shutter section, the section passes green light. A 1 kHz, 60 V_{PP} voltage causes it to pass red light.

Each shutter section is driven by an H-configuration switching amplifier. When excited, the amplifier alternately places +30 V_{DC} (+15 V_{DC} to -15 V_{DC}) and -30 V_{DC} (-15 V_{DC} to +15 V_{DC}) across the section, creating the required 60 V_{PP}.

3.10. Option Boards

Although functions of the Clock Board, Master Option Board, and 4-Channel Analog Option Board differ, they are mounted in the same physical position on the Motherboard (at connectors X81 and

X82) in SIRECUST 1280/1281 monitors. Consequently, only one of the boards can be installed in a monitor at any one time.

3.11. Clock Board

The Clock Board provides a local clock signal for the monitor and is used when the monitor is operated only as a standalone bedside unit. See schematic diagram in Appendix B, Figure B-2.13.

3.12. Master Option Board

Equipped with an A820 RS-232 Sub-option Board and/or A840 Analog Sub-option Boards, a Master Option Board (MOB) provides an adaptable method of interfacing analog output signals and serial communication data between SIRECUST bedside monitors and external devices. Up to four sub-option boards can be fitted simultaneously to a Master Option Board but specific boards must be positioned into specific locations. See the illustrations in Figure 3-18 and Figure 3-21, and the schematic diagrams in Appendix B, Pgs. B-31 thru B-37.

3.12.1. 68008 Processor and Associated Circuitry

The on-board 68008 processor has 64 kBytes of Erasable-Programmable Read-Only-Memory (EPROM) and 32 kBytes of Static Random-Access-Memory (SRAM), and has access to the system in 256 kByte increments. It is configured to access the system bus, the 6844 Direct-Memory-Access controller (DMA), and sub-option board locations.

3.12.2. Direct-Memory-Access Control

A 4-channel 6844 DMA controller manages DMA transfers between any two of the sub-option boards and the MOB's on-board SRAM. Access to sub-option board locations 3 and 4 is in a fixed format. DMA channel 0 is assigned to sub-option board location 3 READ, and channel 1 to 3 WRITE. Channel 2 is assigned to sub-

option board location 4 READ, and channel 3 to 4 WRITE. Data is transferred to and from the sub-option boards as well as from and to the processor SRAM. A Programmable-Array Logic (PAL) state machine in position J17, "DMCT," manages DMA interface and control.

3.12.3. Addressing and Controlling Data Exchange

Sub-option board addressing and control is handled by PAL J22 "DBAD" and PAL J11 "DBSEL" (see Pg. B-34), which have been pre-programmed at the factory to meet the specific needs of the MOB.

The output signal of the address decoder in position J15 (line DGSEL) is used to ENABLE sub-option board decoder J16 and 6800 timer J2. A 6800 timer permits system interface to 6800-type peripherals or other external accessories which have slow-timing circuits. Slow-timing is selected by PAL J11 whenever 68008 address line CA11 is at logic state 1.

The control decoder in position J20 manages interrupt control tasks and READ identification codes, and sets the upper address register in position J51.

Transfer of DATA to and from the system RAM occurs whenever the 68008 address line CA19 is at logic state 1. This allows addressing to 0.5 megabyte of system RAM. In turn, the upper address register, J51, provides access to the entire 32 kBytes of system RAM.

Control of the system bus is initiated by a bus request, BR, (LOW-True), which results in generation of a bus grant, BG, (Low-True) signal. Reception of BG turns PAL J57 "SYBUS" state machine (see Pg. B-35) ON, allowing information to be received. PAL J57 is referred to as the "System Bus Master". It's functions are to generate proper timing sequences for accessing the system bus and to control transceivers J35 and J43.

The PAL J53 "SYDTK" state machine (see Pg. B-35) controls transceivers J54 and J61. During a 68008 bus error, signal DTACKL or BUSERRL ends the bus timing sequence.

Proper operation of sub-option boards using digital-to-analog converters involves use of the 1.25 ms interrupt signal, DAINTL, generated by the 8 MHz clock and synchronized with VSYNC. The signal is presented to the level 5 interrupt of the 68008 processor.

All operations of the processor and DMA controller rely on the 68008 interrupt structure. An external interrupt processor circuit, consisting of PAL "IRQ" (see Pg. B-34) at J26, registers J4 and J18, and the priority encoder at J7, controls the interrupts presented to the 68008 processor.

Communication with the system processor uses the system interrupt lines IRQ1, IRQ2, IRQ3, IRQ6 and lock signal LCKO.

3.12.4. RAM/ROM and Real-Time Clock Circuitry

The system bus has access to RAM/ROM expansion sockets (J36, J37, J38, and J39) through transceivers at J54 and J61 and address buffers at J52 and J62. A PAL, "SADEC," (see Pg. B35) at J60 decodes the address information and selects the proper socket.

The setting of jumper X16 determines the selection of low or high address space. The J53 PAL, "SYDTK," (see Pg. B-34) controls access timing of the DTACK signal, and also enables the transceivers at J54 and J61.

The register-select signal, SEL, enables access to the real-time clock (with calendar) and a self-contained oscillator. Clock information is controlled and passed to the entire system by the PAL, "CLOCK," (see Page B-35) at J24 and the transceiver at J31.

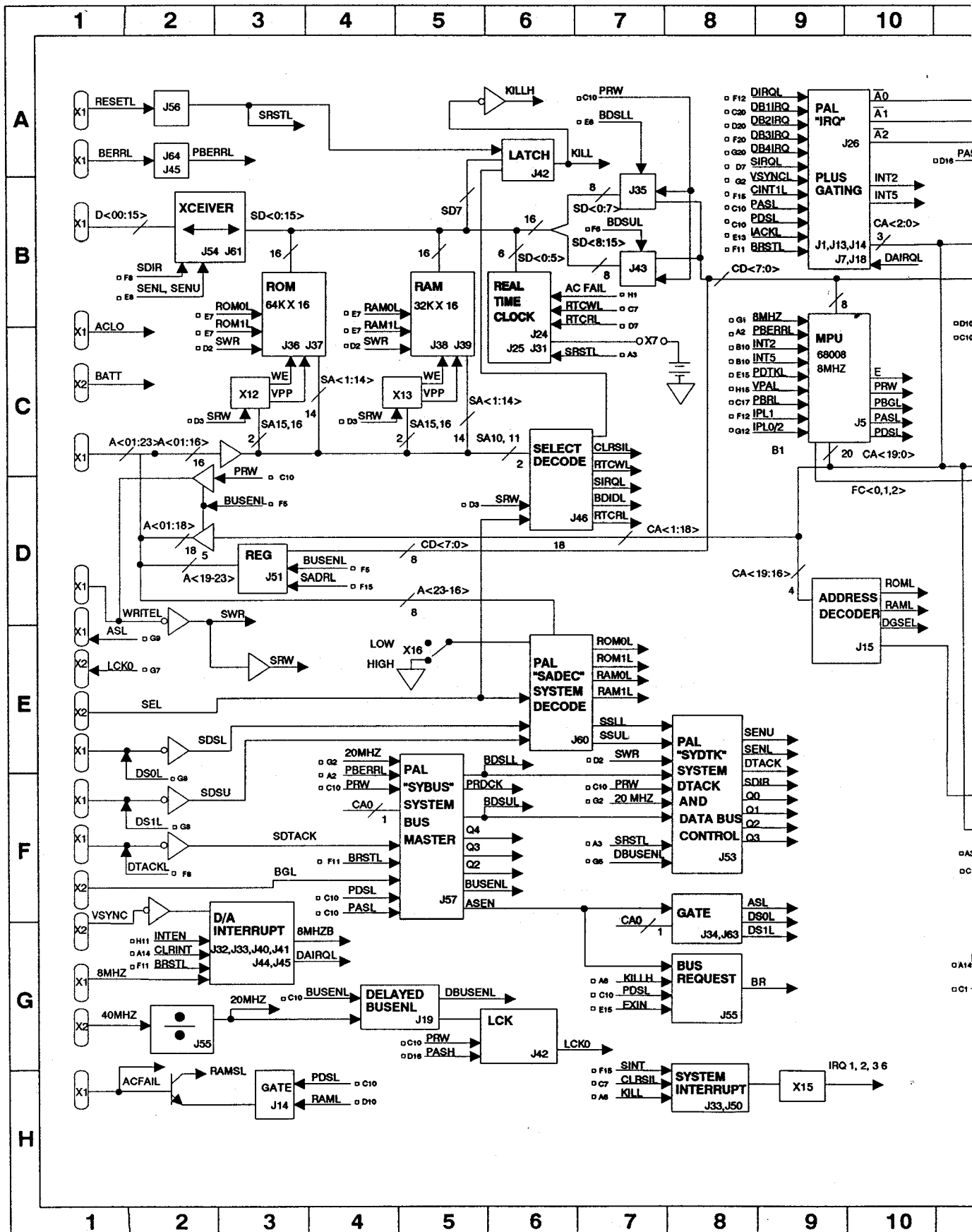
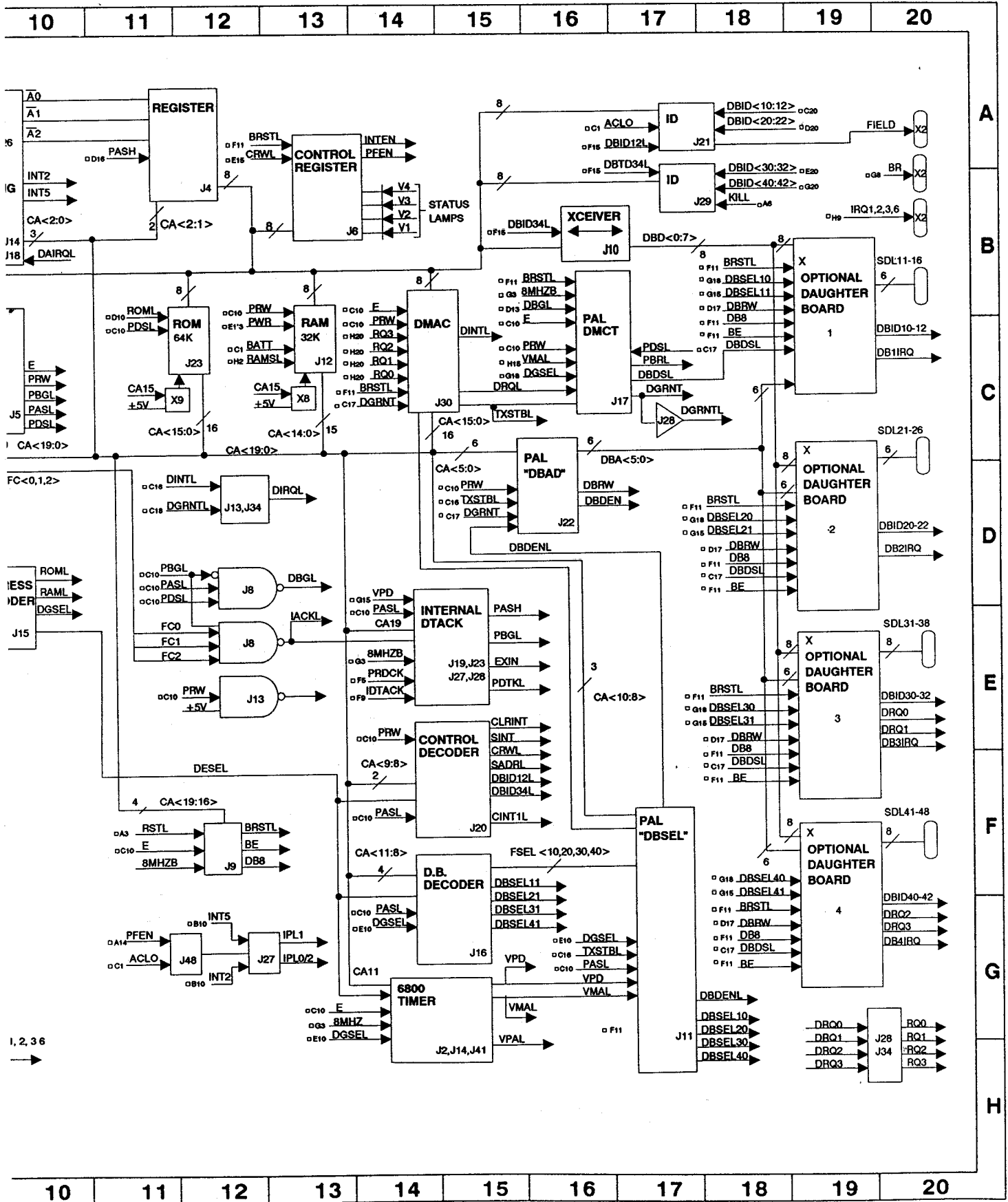

Figure 3-18. Master Option Board Block Diagram

System SIRECUST 1280/1281 Bedside Monitor - Service Manual



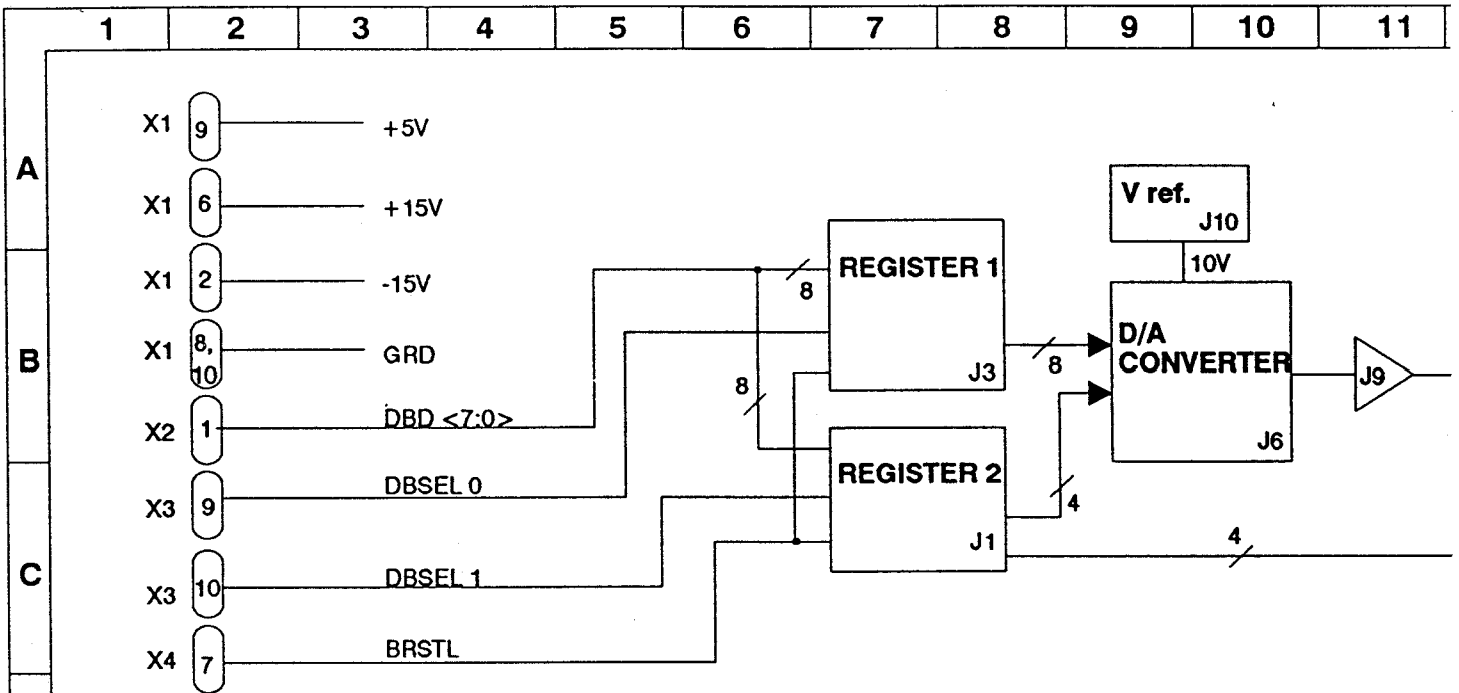

Figure 3-19. Analog Sub-Option Board Block Diagram

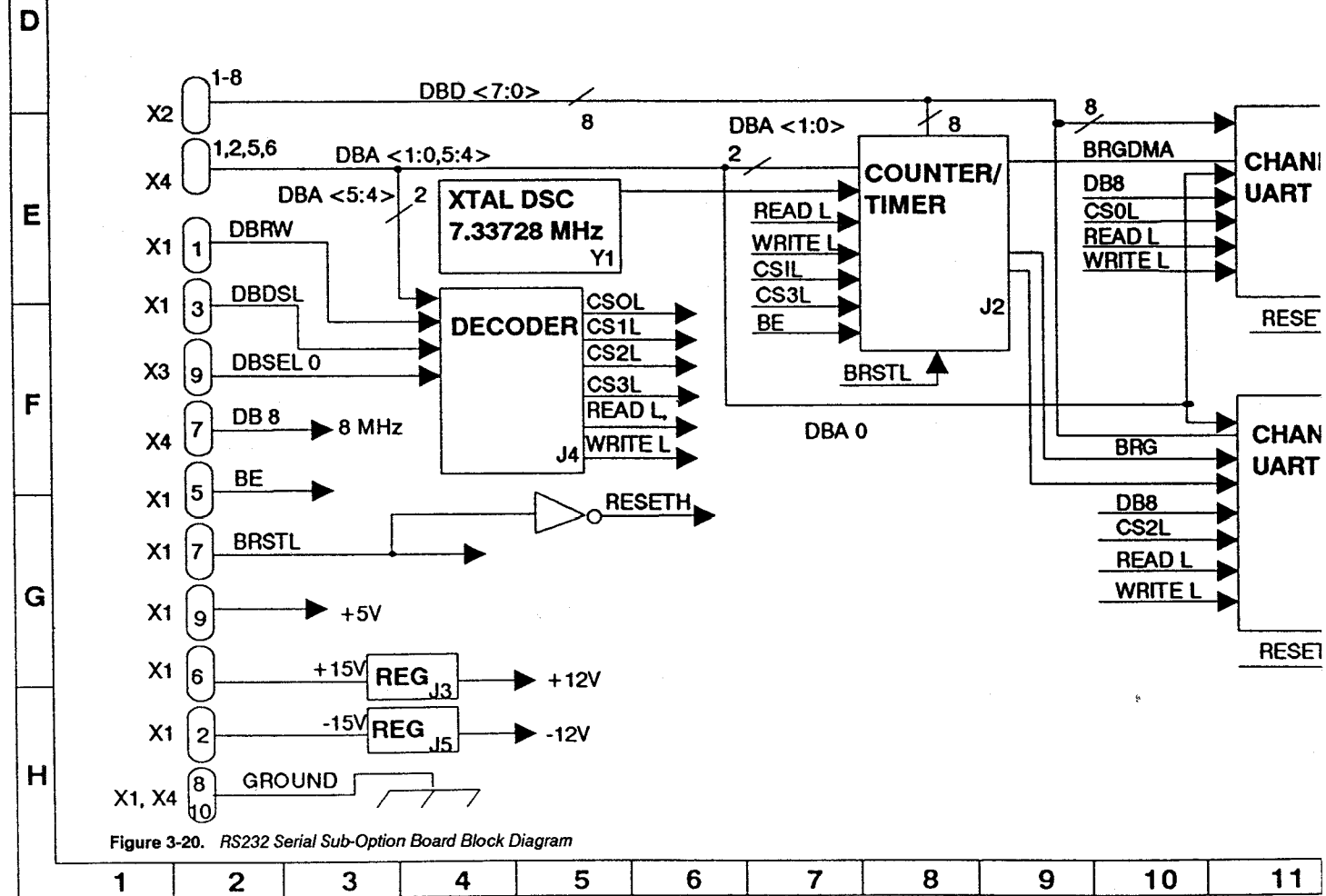
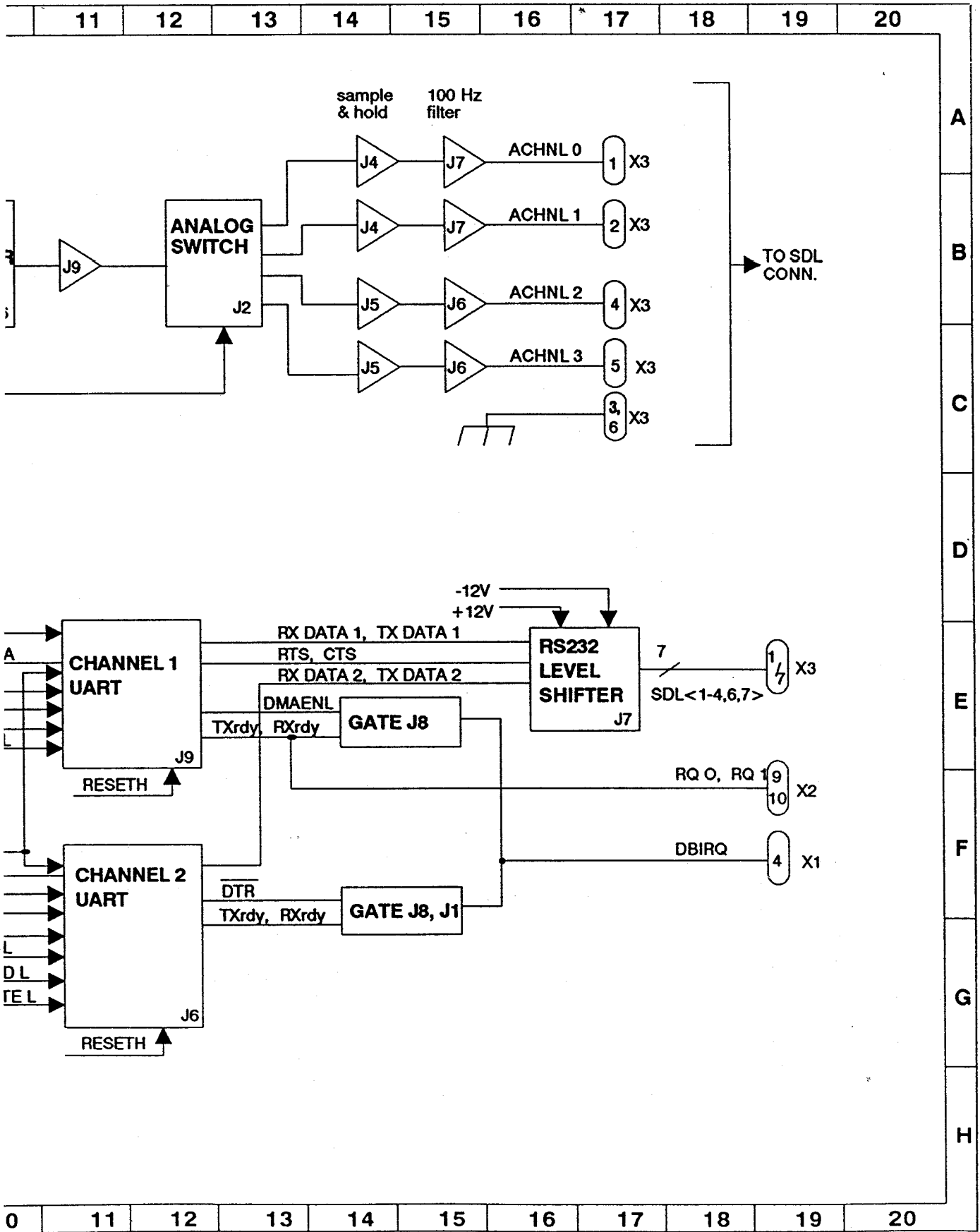

Figure 3-20. RS232 Serial Sub-Option Board Block Diagram



System SIRECUST 1280/1281 Bedside Monitor - Service Manual

A 3-V lithium cell, B1, mounted on the MOB provides battery back-up for the real-time clock circuitry.

NOTE: The MOB is shipped from the factory with the battery inactive to preserve the battery's life expectancy of ten years. Procedures for activating and deactivating the battery are outlined in Chapter 4, Section 4.9. Always deactivate the battery when the MOB is not installed.

3.12.5. Sub-Option Board Locations

MOB hardware is designed to accept sub-option boards at four locations, under software control. The software is installed in position J23 on the MOB. The sub-option boards are software independent. Figure 3-21 illustrates placement of the sub-option boards for software version

VC0-XXM. Under the protocol of this software version, the MOB supports the Analog Sub-Option Boards (ASO) at locations 1, 2, and 3. Locations 1 and 2 supports analog output channels 1 thru 4 and 5 thru 8, respectively. Location 3 provides two special application analog outputs for use as an intra-aortic balloon pump (IABP) interface. Location 4 supports communication of the RS-232 Serial Sub-Option Board (SSO) exclusively.

The 68008 processor and associated circuitry searches for an identification code signal of each individual sub-option board. Once a sub-option board has been installed on a MOB, the output of the sub-option board is processed and terminated at an assigned SDL output connector. The Master Option Board contains 6-pole and 8-pole SDL-type connec-

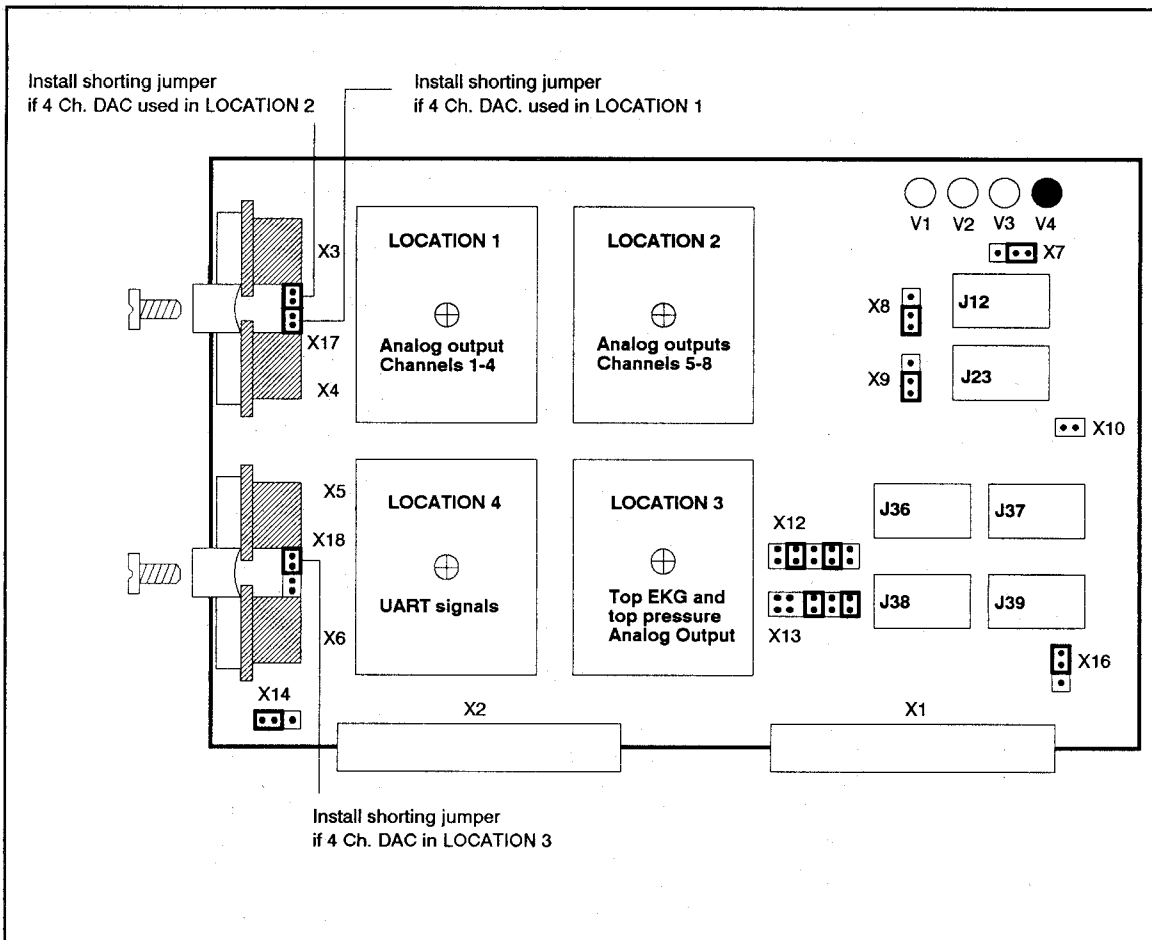

Figure 3-21. Master Option Board: Sub-Option Board Locations

System SIRECUST 1280/1281 Bedside Monitor - Service Manual

Table 3-2. Sub-Option Board Location/SDL Connector/Output Relationships

<u>LOCATION/SLOT</u>	<u>SDL Connector</u>	<u>OUTPUT</u>
1 / B	X3	SDL 6: X5
2 / A	X4	SDL 6: X6
3 / D	X5	SDL 8: X7
4 / C	X6	SDL 8: X8

tors for I/O interface. Table 3-2 shows the relationship between the MOB location, the assigned SDL connector on the MOB, and the assigned System SIRECUST output. Table 3-4 lists the signal assignments for the pins of the SDL connectors.

Table 3-4 is a listing of the signal locations of the master option SDL connectors in relation to each SOB.

Table 3-4. MOB SDL Connector Signal Assignments

<u>SDL PIN</u>	<u>ASO</u>	<u>SSO</u>
1	channel 1	RxD1
2	channel 2	CTS1
3	Analog Ground	TxD1
4	channel 3	RxD2
5	channel 4	Ground
6	Analog Ground	TxD2
7	non-connection	RTS1
8	non-connection	non-connection

3.13. Analog Sub-Option Board

Refer to the block diagram of Figure 3-19 on page 30, and the schematic diagram in Appendix B, Pg. B-36.

Table 3-3. MOB Output Table

<u>SYMBOL</u>	<u>PIN</u>	<u>SIGNAL TYPE</u>	<u>DESCRIPTION</u>
SDL11	X4-1	input / output	SOB 1 I/O connector
SDL12	X4-2	input / output	SOB 1 I/O connector
SDL13	X4-3	input / output	SOB 1 I/O connector
SDL14	X4-4	input / output	SOB 1 I/O connector
SDL15	X4-5	input / output	SOB 1 I/O connector
SDL16	X4-6	input / output	SOB 1 I/O connector
SDL21	X3-1	input / output	SOB 2 I/O connector
SDL22	X3-2	input / output	SOB 2 I/O connector
SDL23	X3-3	input / output	SOB 2 I/O connector
SDL24	X3-4	input / output	SOB 2 I/O connector
SDL25	X3-5	input / output	SOB 2 I/O connector
SDL26	X3-6	input / output	SOB 2 I/O connector
SDL31	X6-1	input / output	SOB 3 I/O connector
SDL32	X6-2	input / output	SOB 3 I/O connector
SDL33	X6-3	input / output	SOB 3 I/O connector
SDL34	X6-4	input / output	SOB 3 I/O connector
SDL35	X6-5	input / output	SOB 3 I/O connector
SDL36	X6-6	input / output	SOB 3 I/O connector
SDL37	X6-7	input / output	SOB 3 I/O connector
SDL38	X6-8	input / output	SOB 3 I/O connector
SDL41	X5-1	input / output	SOB 4 I/O connector
SDL42	X5-2	input / output	SOB 4 I/O connector
SDL43	X5-3	input / output	SOB 4 I/O connector
SDL44	X5-4	input / output	SOB 4 I/O connector
SDL45	X5-5	input / output	SOB 4 I/O connector
SDL46	X5-6	input / output	SOB 4 I/O connector
SDL47	X5-7	input / output	SOB 4 I/O connector
SDL48	X5-8	input / output	SOB 4 I/O connector

The 4-channel digital to analog (D/A) converter sub-option board (ASO) provides four independent ± 5 volt analog output signal channels. These signals can be used to "drive" external equipment with analog output signals derived from the System SIRECUST bedside monitor, using a SIEMENS accessory cable for connecting to external equipment from the output SDL connectors provided on the MOB. Consult Table 3-4 for signal assignments of the ASO.

NOTE: Listings of recommended cables are in the monitor's Operating Instructions, SIEMENS publication Order No. A91004-M3331-L079-XX-7600.

3.13.1. Functional Operation

Circuitry of the ASO consists of two 8-bit registers, a bipolar 12-bit D/A converter, an operational amplifier, an analog switch, four independent sampling and hold circuits, and four independent 2-pole active filters. Input data from the MOB is written into the two input registers, J1 and J3, using the signals DBSEL0 and DBSEL1. The lower 8 bits of a data word are written by the signal DBSEL0. The upper 4 bits of the data word, along with the selected output channel bit, are written by the signal DBSEL1.

After data has been written into registers J1 and J3, output of the bipolar D/A converter, J6, is amplified by operational amplifier J9. The amplified output is routed to analog switch J2. At this stage the output of the analog switch is stored within the selected sample and hold circuits, J4 and J5. The output of the sample and hold circuit passes through low pass filters J7 and J8 to the output of the selected channel.

To produce an analog output from any one of the four channels, a specific channel and its data must be selected and written. The sampling rate of selecting and writing is 200 samples/second or 5 ms per sample. This process uses a

1.25 ms D/A interrupt task in conjunction with a controlled software routine from the MOB. On receipt of the interrupt task the software searches, retrieves the desired data point, and writes the lower 8 bits to the first register. With the selected-channel bit "OFF", the upper 4 bits are written. After this sequence, the upper 4 bits are written a second time, with the selected-channel bit "SET". After a timed delay of approximately 500 μ s the upper 4 bits are written again with the selected-channel bit "OFF". This routine is repeated every 1.25 ms D/A interrupt intervals.

Refer to Table 3-5 for a summary of input/output signal flow and relationship between the ASO board connectors.

3.13.2. Location vs. Signal Priority

An ASO board installed on the MOB produces the analog waveforms assigned to that specific option location. Analog output signals corresponding to the displayed channels on the monitor are available at the monitor's back panel. The software directs the monitor to send the first eight highest priority waveforms and parameter blocks in a descending order.

Refer to current Operating Instructions, SIEMENS Order No. A91004-M3331-L079-XX-7600, for parameter and priority.

3.14. RS-232 Serial Sub-Option Board

Refer to Figure 3-20 and Appendix B.

3.14.1. Functional Operation

The RS-232 Serial Sub-Option Board (SSO) provides 2-serial ports for RS-232 communication. Port 1 is a full hand-shake port with the operations ready-to-send (RTS), clear-to-send (CTS), and direct-memory-access (DMA). Port 2 is a simplified port with only receive (Rx) and transmit (Tx). Each port is capable of synchronous and/or asynchronous process at a rate of up to 38.4 kilobaud.

Table 3-5. ASO Input/Output Connector Table

<u>SYMBOL</u>	<u>PIN</u>	<u>TYPE</u>	<u>DESCRIPTION</u>
- 15v	X1-2	Input	- 15v Power Input
+ 15v	X1-6	Input	+ 15v Power Input
+ 5v	X1-9	Input	+ 5v Power Input
GROUND	X1-8		Ground
GROUND	X1-10		Ground
DBD0	X2-1	Input	ASO data - HI true
DBD1	X2-2	Input	
DBD2	X2-3	Input	
DBD3	X2-4	Input	
DBD4	X2-5	Input	
DBD5	X2-6	Input	
DBD6	X2-7	Input	
DBD8	X2-8	Input	
ACHNLO	X3-1	Output	Analog Channel 1
ACHNL1	X3-2	Output	Analog Channel 2
SGRD	X3-3		Signal Ground
SGRD	X3-6		Signal Ground
ACHNL2	X3-4	Output	Analog Channel 3
ACHNL3	X3-5	Output	Analog Channel 4
DBSEL-9	X3-9	Input	ASO Select 0: loads lower 8 bits of D/A converter
DBSEL1	X3-10	Input	ASO Select 1: loads upper 4 bits of D/A converter and 4 channel select

The SSO has two programmable UART channels. Each channel consists of a programmable counter/timer used for a baud-rate generator and an RS 232 level shifter.

Channel 1, J9, is a full serial communications channel with Rx (receive), Tx (transmit), RTS (ready to send), and CTS (clear to send) operations. Data transmitted or received on this channel is capable of being transferred to and from local memory governed by DMA control.

The direct transmit-receive signal, DTR, is used to enable as well as disable the interrupt request line from channel 2 UART. Signals RQ0 and RQ1 are always active, and their service depends

on the operation of the DMA controller located on the MOB.

Channel 2, J6, is a simple asynchronous Rx/Tx channel. The DTR signal is used to enable and disable the transmit interrupt sequence. Device J7 converts the RxD/TxD signals to RS-232 levels.

Table 3-6. Input/Output Connector Table

<u>SDL PIN</u>	<u>ASO</u>	<u>SSO</u>
1	channel 1	RxD1
2	channel 2	CTS1
3	Analog Ground	TxD1
4	channel 3	RxD2
5	channel 4	Ground
6	Analog Ground	TxD2
7	non-connection	RTS1
8	non-connection	non-connection

System SIRECUST 1280/1281 Bedside Monitor - Service Manual

Table 3-7. MOB Jumper Table

<u>JUMPER</u>	<u>DESCRIPTION</u>	<u>POSITION</u>	<u>FUNCTION</u>
X7	Clock Battery Power	1-2 3-4	Clock Off Clock On
X8	68008 RAM Select	1-2 2-3	8K X 8 32K X 8
X9	68008 PROM Select	1-2 2-3	32K X 8 64K X 8
X10	Clock Alignment	NO JUMPER JUMPER	NORMAL FACTORY USE
X14	D/A Interrupt Select	1-2 2-3	800 Hz.(1.25ms) 1600 Hz.(623us)
X15	System Interrupt Select	1-2 3-4 5-6 7-8	IRQ1 DEFAULT IRQ2 IRQ3 IRQ6
X16	System RAM/ROM Space Select	1-2 2-3	050000-07FFFF 8C0000-90FFFF
X17	with Analog Option 5-8 only (X3)	1-2	USE JUMPER
X17	with Analog Option 1-4 only (X4)	3-4	USE JUMPER
X18	with Analog Option 1-2 only (X5)	1-2	USE JUMPER
X18	with dedicated RS-232 only (X6)	3-4	NO JUMPER

<u>CONFIG</u>	<u>JUMPERS</u>	<u>LOW ADDRESS</u>	<u>HIGH ADDRESS</u>
---------------	----------------	--------------------	---------------------

X12 Optional system RAM / PROM select: J36 and J37

64K PROM	B , D	050000-06FFFF	8F0000-90FFFF
32K PROM	B , E	050000-05FFFF	8F0000-8FFFFF
16K PROM	A , C	050000-05FFFF	8F0000-8FFFFF
8K PROM	A , C	05C000-05FFFF	8FC000-8FFFFF

X13 Optional system RAM / PROM select: J38 and J39

64K	B , D	N/A	8F0000-9FFFFF
32K	B , E	070000-07FFFF	8F0000-8FFFFF
16K	A , C	070000-07FFFF	8F0000-8FFFFF
8K	A , C	07C000-07FFFF	8FC000-8FFFFF

A COUNTER/TIMER device, J2, provides the baud rate clocks for the UART devices, J6 and J9. Pinout assignments for the SSO board SDL connector on the rear panel of the monitor are listed in Table 3-6. Input/output signals and relationship between the SSO hardware connectors is given in Table 3-8.

3.15. 4-Channel Analog Option Board

Refer to the schematic diagram in Appendix B, Pgs. B-39 and B-40.

Digital data are supplied to a D/A converter (AD6012), J10, by a 8 X 12 high-speed RAM (J11, J12, and J18). The

System SIRECUST 1280/1281 Bedside Monitor - Service Manual

registers of the RAM are loaded with curve data from the main processor during the vertical sync flyback interval, VSYNC. The time during which the system processor can write the register file is determined by the signal, WRTIME. If the processor addresses the local RAMs with corresponding data outside the VSYNC interval, a DTACK is not generated and the bus-timer/refresh-counter (Display Processor Board) generates a bus error.

During the VSYNC interval, after the system processor writes the appropriate data in the RAM the internal timing generator starts. The address selects the data which are applied to AD6012. After being converted to analog the data are amplified and applied to the analog switch, J14. Selection of Channel 1 to 4 is made through multiplexer J5, by signals Q_B and Q_C of the timing generator.

Table 3-8. SSO Input/Output Connector Table

<u>SYMBOL</u>	<u>PIN</u>	<u>SIGNAL TYPE</u>	<u>DESCRIPTION</u>
DBRW	X1-1	input	SOB Read-Write High = Read ; Low = Write
- 15v	X1-2	input	- 15 Volt Power
DBDSL	X1-3	input	SOB Data Strobe, low true
DDIRQ	X1-3	output	SOB Interrupt Request Low True, open collector
BE	X1-5	input	Buffered "E" Clock
+ 15V	X1-6	input	+ 15 Volt Power
DB8	X1-7	input	Buffered 8 Mhz.
+ 5V	X1-9	input	+ 5V Power Input
GRD	X1-8		Ground
GRD	X1-10		Ground
DBD0	X2-1	input/output	SOB Data, HI = true
DBD1	X2-2	(tri-state)	
DBD2	X2-3		
DBD3	X2-4		
DBD4	X2-5		
DBD5	X2-6		
DBD6	X2-7		
DBD7	X2-8		
RQ0	X2-9	output	DMA request, Receive Data
RQ1	X2-10	output	DMA request, Transmit Data
SDL1	X3-1	input	Receive Data - Channel 1
SDL2	X3-2	input	Clear to Send - Channel 1
SDL3	X3-3	output	Transmit Data - Channel 1
SDL4	X3-4	input	Receive Data - Channel 2
SDL5	X3-5	-	Signal Ground
SDL6	X3-6	output	Transmitted Data - Channel 1
SDL7	X3-7	output	Request to Send - Channel 1
DBSELO	X3-9	input	SOB Select 1 ; chip select for devices
DBA0	X4-1	input	SOB Address, HI = true
DBA1	X4-2	input	
DBA4	X4-5	input	
DBA5	X4-6	input	
BRSTL	X4-7	input	Reset, Clears uPD71051 UART

Four capacitors (C8, C15, C29, C39) and operational amplifiers J4, J7, J13, and J19 perform a "sample-and-hold" function. The 4 analog signals are routed through low-pass filters having a cutoff frequency of 75 Hz, and are available at the 6-pole SDL socket X3 (X7 on the rear panel) and test points TP1 ... TP4.

3.16. Memory Extension Board

A Memory Extension Board must be installed for operation of monitors equipped with software version VE (or subsequent versions) and Rev. 1 and Rev. 2 Front End Boards, SIEMENS Art. No. 87 91 378 E2501 A190. See the schematic diagram in Appendix B, Pgs. B-41 and B-42. Future revisions of the Front End Board will incorporate extended memory directly on the board.

3.17. Motherboard

Refer to the schematic diagram in Appendix B, Pgs. B-43 and B-44.

Connectors for installing all signal processing boards in the monitor are contained on the Motherboard. Refer to the schematic diagram in Appendix B for the specific signal, power, and control lines available to each board through the connector on the Motherboard.

A piezoelectric buzzer mounted on the Motherboard sounds in the event of power failure to the monitor.

3.18. Line Driver Board

Refer to schematic diagram in Appendix B, Pg. B-12.

In installations that have a SIRECUST 120S/121S repeater scope unit connected directly to a SIRECUST 1280/1281 Monitor, a Line Driver Board is installed in the monitor to buffer the signals from the Curve Board to the 120S/121S. The board plugs directly into the X5, X7, and X8 connectors on the top edge of the Curve

Board, and connectors X7 and X8 from the Deflection Board wiring harness plug into positions on the Line Driver Board. Refer to Figure 4-4 in Chapter 4. The board uses an output wire harness and D connector secured to position X3 on the back of the monitor chassis for interface with the SIRECUST 120S/121S.

3.19. Memory Backup

Refer to the schematic diagrams in Appendix B, Pgs. B-38 and B-45.

Essentially, two kinds of memory backup are used in the monitors to minimize loss of data, and to power the piezoelectric alarm in the event of a main power failure. Signal line AC INTO from the monitor power supply activates the backup function through the Display Processor Board.

The first kind of backup circuitry, the A931 Battery Board, relies on a nicad battery mounted directly on the chassis and connected to the board by a wire harness. The second kind of backup circuitry, the A933 Memory Backup Board, relies on the charge stored in a 1/2 farad capacitor to sound the piezo alarm and provide power to prevent loss of memory for 30 minutes.

Both kinds of memory backup boards mount in the same location in the monitor. Refer to Chapter 4, Section 4.13 for additional information.

3.20. Operational Support Equipment

3.20.1. Remote Cartridge Unit (SIREM)

Although not constructed as part of the monitor, a remote cartridge unit (SIREM) is required to house parameter cartridges that provide the physiological data signals to the monitor. See Figure 3-22. A minimum requirement for operation of a monitor is normally SIREM equipped with a LIM cartridge. Refer to Section 3.20.2.

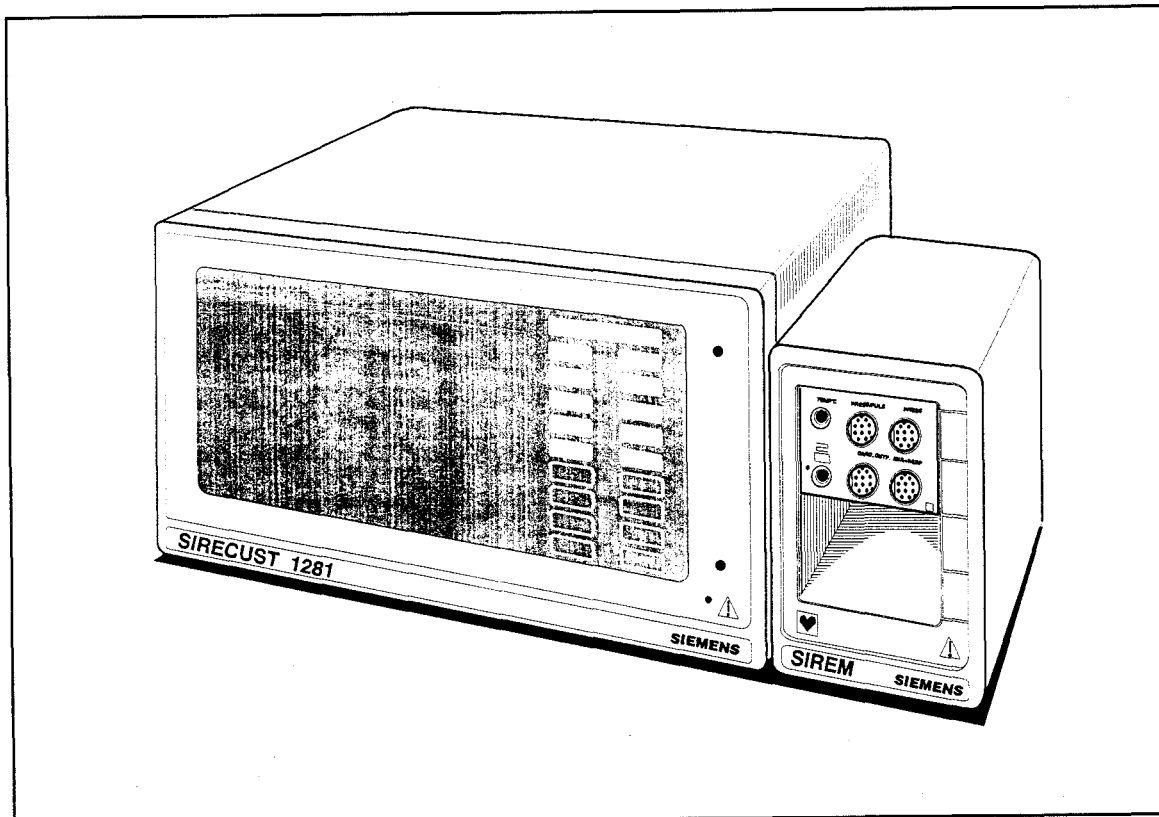

Figure 3-22. Monitor with SIREM and LIM

SIRECUST 1280/1281 monitors can support up to two SIREMs, each connected to the Front End Board in the monitor by a single shielded cable which can be up to 20 meters long. The unregulated 15 V_{DC} needed by the SIREM to power the cartridges is also provided via the cable. The voltage is regulated to a 5 volt supply to the differential amplifiers. A SYNC pulse from the main frame provides the chopper frequency for the primary transformer side of the cartridges. In this way power inside the cartridge is synchronized to the overall power supply in the system. Cartridges require no power ON-OFF switch, and the design is such that even an open primary transformer will not overheat.

The monitor provides the clock and CC bits for all four channels in the SIREM. Because of the lengths of the interconnection cable digital data is received via a differential input. The received

optical information from up to four cartridges is summed together into two signal passes. This doubles the data acquisition speed per cartridge to 2400 samples per second. The total conversion per SIREM is 9600 samples per second. In addition, the SIREM supports a foot switch for cardiac output, through an input connector at the rear of the unit.

The Coupler Card Assembly (A1) in the rear of the SIREM contains all electrical interfaces for each of the up to four cartridges. The electrical interfaces are effected by transformer, optical, and mechanical couplings. No galvanic electrical circuits are completed between a cartridge circuitry and the monitor components.

Power for each cartridge is obtained via a patented transformer coupling. The transformer secondary in the cartridge is spring loaded to maintain pressure

against the inner surface of the rear panel membrane of the SIREM, while the primary is mounted on the coupler board and is spring loaded to maintain pressure against the membrane within the SIREM. The transformer has been designed for 5 kV breakdown voltage.

Digital signals to and from the cartridge are transmitted and received via optical coupling through rear-panel windows to assure electrical isolation of the patient. Up to four physiological parameter cartridges may be inserted in the SIREM cartridge enclosure. Since each cartridge communicates its identity to the main-frame processor and control unit by a unique binary code, except for the LIM any cartridge may be inserted in any cartridge slot. The LIM cartridge must be inserted into SIREM 1 slots 1 and 2.

3.20.2. LIM Cartridge

The LIM Cartridge (Large Integrated Multiparameter Cartridge) is a combination of eight physiological parameter data acquisition channels in the enclosure of a dual height SIRECUST cartridge, and is frequently considered a minimum requirement in populating a SIREM. It is inserted only into the top two slots of a SIREM, and supports either a three lead or a five lead EKG cable with four individual EKG channels. In addition the software in the monitor calculates the augmented EKG leads AVR, AVL, AVF and therefore enables the simultaneous display of up to seven EKG waveforms.

The LIM cartridge also supports two pressure channels, detects respiration independently of the selected EKG lead configuration or with a nasal respiration probe, supports two of the YSI Series 400 temperature sensors, and can be used with an Edwards catheter or inline injectate sensor for cardiac output measurement.

No operating controls are on the cartridge front-panel. All controls are on the

monitor. Also, the front-panel connectors are color coded and mechanically keyed for each transducer cable type.

The LIM cartridge is powered by a connectorless inductive power coupling mechanism in the SIREM. Because of special low power circuitry, the total power consumption of the LIM cartridge is kept below 3.5 watts.

Digital communication to and from the monitor via the SIREM is by optical means. The Front End Board of the monitor synchronizes and controls the LIM cartridge. The monitor CPU recognizes an occupied channel by sensing the incoming data stream. The screen display will be blanked in that channel when no cartridge is installed in the corresponding slot.

CHAPTER 4

REMOVING/INSTALLING SYSTEM COMPONENTS

TABLE OF CONTENTS

4.	REMOVING/INSTALLING SYSTEM COMPONENTS	1
4.1.	Opening/Closing the Monitor	1
4.1.1.	Removing the Outer Case	1
4.1.2.	Installing the Outer Case	2
4.2.	Power Supply, A140/A280	2
4.2.1.	Removing the Power Supply	2
4.2.2.	Installing the Power Supply	3
4.3.	Signal Processing and Control Boards --	
	• Curve Board, A130/A270	
	• Display Processor, A171/A371/A372	
	• Front End Board, A190	
	• Memory Extension, A400	
	• Clock Board, A960, Master Option Board, A810, or 4-Ch Analog Option Board, A971	3
4.4.	Curve Board, A130/A270	4
4.4.1.	Removing the Curve Board	4
4.4.2.	Replacing/Installing Software	5
4.4.3.	Installing the Curve Board	5
4.5.	Line Driver Board, A300	5
4.5.1.	Removing a Line Driver Board	6
4.5.2.	Installing a Line Driver Board	6
4.6.	Display Processor Board, A171/A371/A372	7
4.6.1.	Removing the Display Processor Board	7
4.6.2.	Replacing/Installing Software	7
4.6.3.	Installing Display Processor	7
4.7.	Front End Board, A190	7
4.7.1.	Removing the Front End Board	8
4.7.2.	Replacing/Installing Software	8
4.7.3.	Installing Front End Board	8
4.8.	Memory Extension Board, A400	8
4.8.1.	Removing the Memory Extension Board	8
4.8.2.	Replacing/Installing Software	9
4.8.3.	Installing the Memory Extension Board	9

TABLE OF CONTENTS (Continued)

4.9.	Clock Board, A960, Master Option Board, A810, or 4-Ch Analog Option Board, A971	9
4.9.1.	Removing the Clock Board, Master Option Board, or 4-Ch Analog Option Board	9
4.9.2.	Replacing/Installing Software on the Master Option Board	10
4.9.3.	Activating/Deactivating MOB Backup Battery	10
4.9.4.	Installing Sub-Option Boards (SOB)	11
4.9.5.	Installing the Clock Board, Master Option Board, or 4-Ch Analog Option Board	11
4.10.	Deflection Board, A160/A310	11
4.10.1.	Removing the Deflection Board	11
4.10.2.	Installing the Deflection Board	13
4.11.	Z-Amp Board, A181/A261	13
4.11.1.	Removing the Z-Amp Board	13
4.11.2.	Installing the Z-Amp Board	14
4.12.	Operator Interface Board, A291/A292	14
4.12.1.	Removing the Operator Interface Board	14
4.12.2.	Replacing/Installing Software	14
4.12.3.	Installing the Operator Interface Board	15
4.13.	Battery Board, A931, or Memory Backup Board, A933	16
4.13.1.	Removing Battery Board or Memory Backup Board	16
4.13.2.	Installing the Battery Board or Memory Backup Board	17
4.14.	Nicad Battery Subassembly	17
4.14.1.	Removing the Nicad Battery Subassembly	17
4.14.2.	Installing the Nicad Battery Subassembly	17
4.15.	Speaker Assembly	18
4.15.1.	Removing the Speaker Assembly	18
4.15.2.	Installing the Speaker Assembly	19
4.16.	Motherboard, A100	19
4.16.1.	Removing the Motherboard	19
4.16.2.	Installing the Motherboard	20
4.17.	Front Panel Subassembly	21
4.17.1.	Replacing the Name Strip	21
4.17.2.	Removing the Front Panel Subassembly	21
4.17.3.	Installing the Front Panel Subassembly	22
4.17.4.	Replacing the Language Label	22
4.18.	Color Shutter (only on SIRECUST 1281 monitors)	23
4.18.1.	Removing the Color Shutter	23
4.18.2.	Installing the Color Shutter	23

TABLE OF CONTENTS (Continued)

4.19.	CRT	23
4.19.1.	Removing the CRT	23
4.19.2.	Installing the CRT	24
4.20.	Main Power Input Line Filter	25
4.20.1.	Removing the Main Power Input Line Filter	25
4.20.2.	Installing the Main Power Input Line Filter	25
4.21.	Replacing Fuses	26
4.21.1.	Main Power Line Input Fuses	26
4.21.2.	F1, F2 - Power Supply Board	26

LIST OF FIGURES

Figure 4-1.	Removing/Installing Outer Case	1
Figure 4-2.	Location of Power Supply, A140/A280	2
Figure 4-3.	Signal Processing and Control PC Board Locations	4
Figure 4-4.	Line Driver Board Installation	6
Figure 4-5.	Line Driver Board D Connector Mounting Detail	7
Figure 4-6.	Master Option Board Configuration	10
Figure 4-7.	Location of Deflection Boards, A160/A310, and Z-Amp Boards, A181/A261	12
Figure 4-8.	Location of Operator Interface Board, A291/A292, and Card Support Plate	15
Figure 4-9.	Location of Battery Board, A931, or Memory Backup Board, A933	16
Figure 4-10.	Location of Speaker Assembly	18
Figure 4-11.	Location of Motherboard	19
Figure 4-12.	Front Panel Subassembly	20
Figure 4-13.	Color Shutter and Language Label	22
Figure 4-14.	Mounting of CRT	24
Figure 4-15.	Main Power Input Line Filter	25
Figure 4-16.	Main Power Input Fuses	26
Figure 4-17.	F1 and F2 on Power Supply Board	26

4. REMOVING/INSTALLING SYSTEM COMPONENTS

Introduction: Before attempting to remove the monitor cover or disassemble the monitor always do the following for personal safety and to protect equipment:

- Switch the main power OFF.
- Disconnect the main power cable and all other cables attached to the monitor.

CAUTION: SIRECUST 1280/1281 monitors contain electronic components that can be damaged by electrostatic discharge. Open the monitor case only in a static-protected environment. Observe standard procedures for protecting the equipment from static electricity.

NOTE: Since all procedures in this Chapter assume that only the part or subassembly identified in the major Section heading is to be removed or installed (replaced), there tends to be

redundancy in the description of some procedures. "Remove" instructions assume that the procedure begins with a completely assembled monitor. "Install" instructions, assume that the monitor has been disassembled to the extent that it is ready to have the subassembly installed.

4.1. Opening/Closing the Monitor

Refer to Figure 4-1.

4.1.1. Removing the Outer Case

NOTE: For personal safety and protection of equipment, observe all precautions stated in the Introduction section of this Chapter.

1. Remove and save the five Phillips-head screws and washers securing the outer case to the monitor chassis.
2. Slide the outer case towards the rear of the chassis and lift it off the monitor.

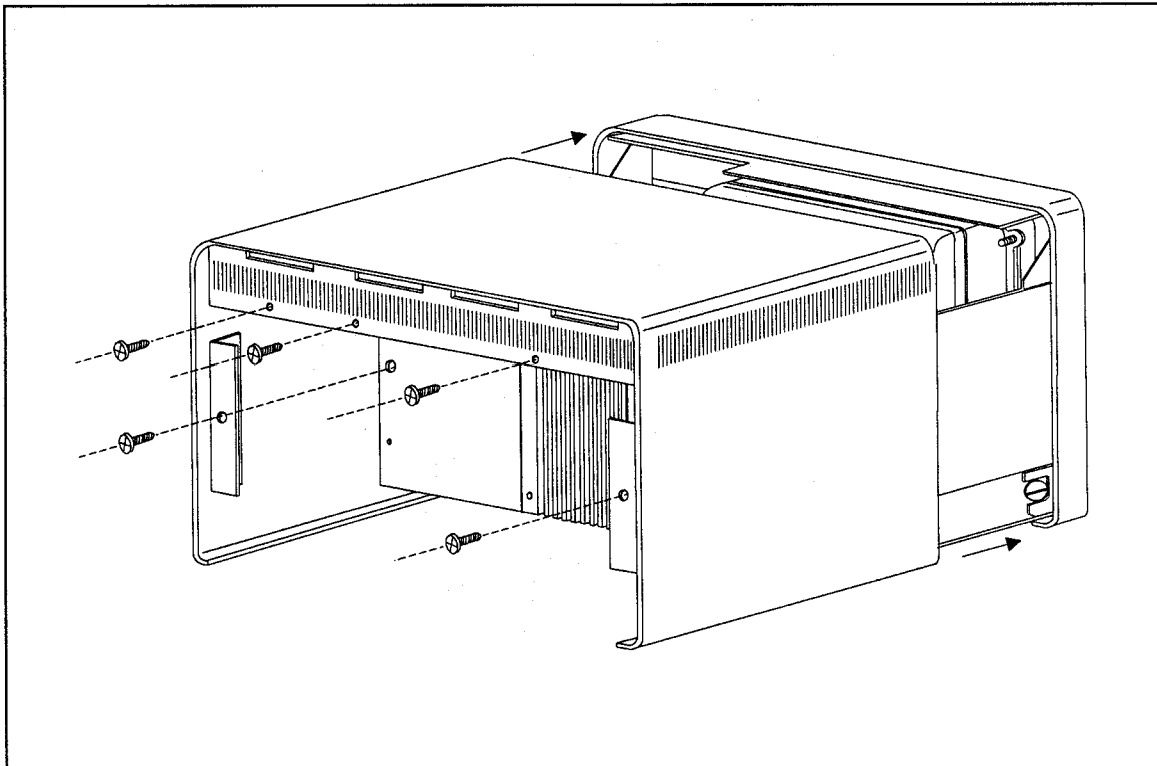

Figure 4-1. Removing/Installing Outer Case

4.1.2. Installing the Outer Case

1. Slide the outer case onto the monitor chassis from the rear of the monitor, so that the front of the case is seated in its channel on the top and sides of the front panel and the five mounting screw holes in the rear of the case align with the mounting holes in the chassis.
2. Insert five Phillips-head screws with washers into the mounting holes, and tighten the screws to secure the outer case to the chassis.

NOTE: Insure that all five screws are in place and tight, and that the outer case is secured, to seal the unit from rf or electromagnetic field interference.

4.2. Power Supply, A140/A280

Refer to Figure 4-2.

4.2.1. Removing the Power Supply

1. Remove the monitor's outer case following the procedure outlined in Section 4.1.1.
2. Disconnect the power cable assembly plugs marked X1, X2, and X3 on the top edge of the power supply PC board. The power supply is located between the CRT shield and the left side panel of the monitor chassis.
3. Remove and save the two Phillips-head screws (A) securing the power supply to the monitor side panel.

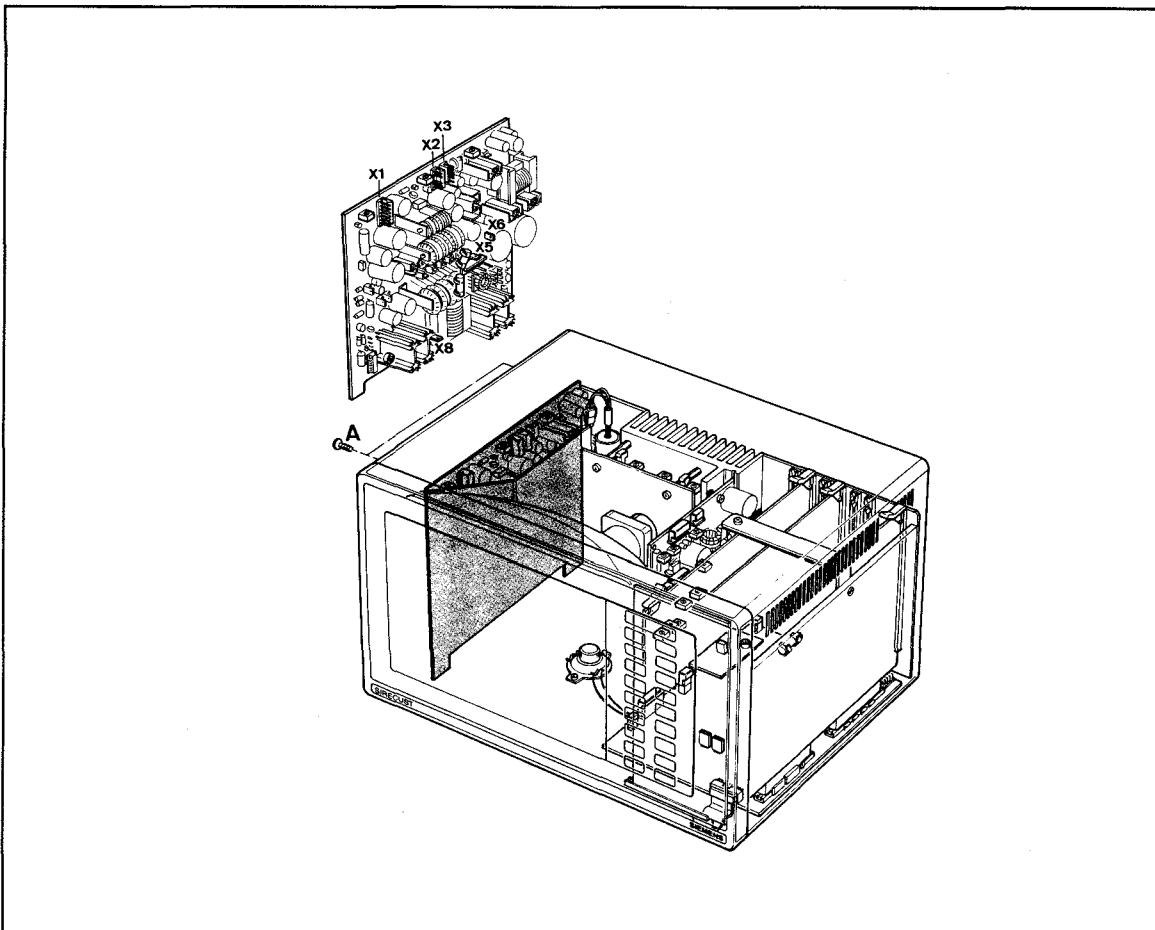

Figure 4-2. Location of Power Supply, A140/A280

4. Lift the power supply vertically to remove it from its positioning slot in the monitor chassis.
5. Disconnect the GRN/YEL grounding wire plug connecting the power supply circuitry to the ground on the main power line filter, at connector X8 on the power supply PC board.
6. Disconnect the input from the main power line filter to the power supply at connectors X5(BLU) and X6(BRN) on the power supply PC board.

NOTE: Some monitors have a line filter wiring subassembly equipped with a keyed in-line connector between the filter and connectors X5 and X6 on the power supply PC board. The connector is an aid to removing and installing the power supply PC board. Both socket and plug sections of the connector are considered to be part of the wiring subassembly of the main power line filter.

4.2.2. Installing the Power Supply

1. Verify the positioning of jumper JP1 in accordance with the configuration given in Appendix C.
2. Attach the brown and blue wires from the line filter subassembly to X5(BLU) and X6(BRN) on the power supply PC board. See note under Section 4.2.1, Step 6.
3. Connect the plug on the GRN/YEL ground wire from the main power input filter to connector X8 on the power supply PC board.
4. Carefully lower the power supply into position in the monitor between the CRT shield and the left side panel. Be sure the lower edge of the power supply PC board is firmly seated on the

bottom of the monitor chassis in the channel directly adjacent to the side panel.

5. Insert two Phillips-head screws (A) through the left side panel into the standoffs on the bottom of the power supply PC board, and secure the board to the panel.

NOTE: The standoff nearest the front of the monitor is also a PC board grounding point.

6. Connect the power cable assembly plugs X1, X2, and X3 to their connectors on the PC Board.
7. Verify the voltage levels for the +5 VDC and +15 VDC supply voltages in accordance with procedures outlined in Chapter 7, and adjust as required.
8. Reinstall the outer case of the monitor following the procedure outlined in Section 4.1.2.

4.3. Signal Processing and Control Boards --

- Curve Board, A130/A270
- Display Processor, A171/A371/A372
- Front End Board, A190
- Memory Extension, A400
- Clock Board, A960, Master Option Board, A810, or 4-Ch Analog Option Board, A971

Refer to Figure 4-3.

The first four boards listed are 12 inches (30 cm) long and are located in specific positions in the 12 inch (30 cm) section of the monitor adjacent to the right side panel. The last three boards are 10 inches (25 cm) long, and the slot into which any one of them can be inserted is positioned adjacent to the CRT outside the 12 inch (30 cm) board section.

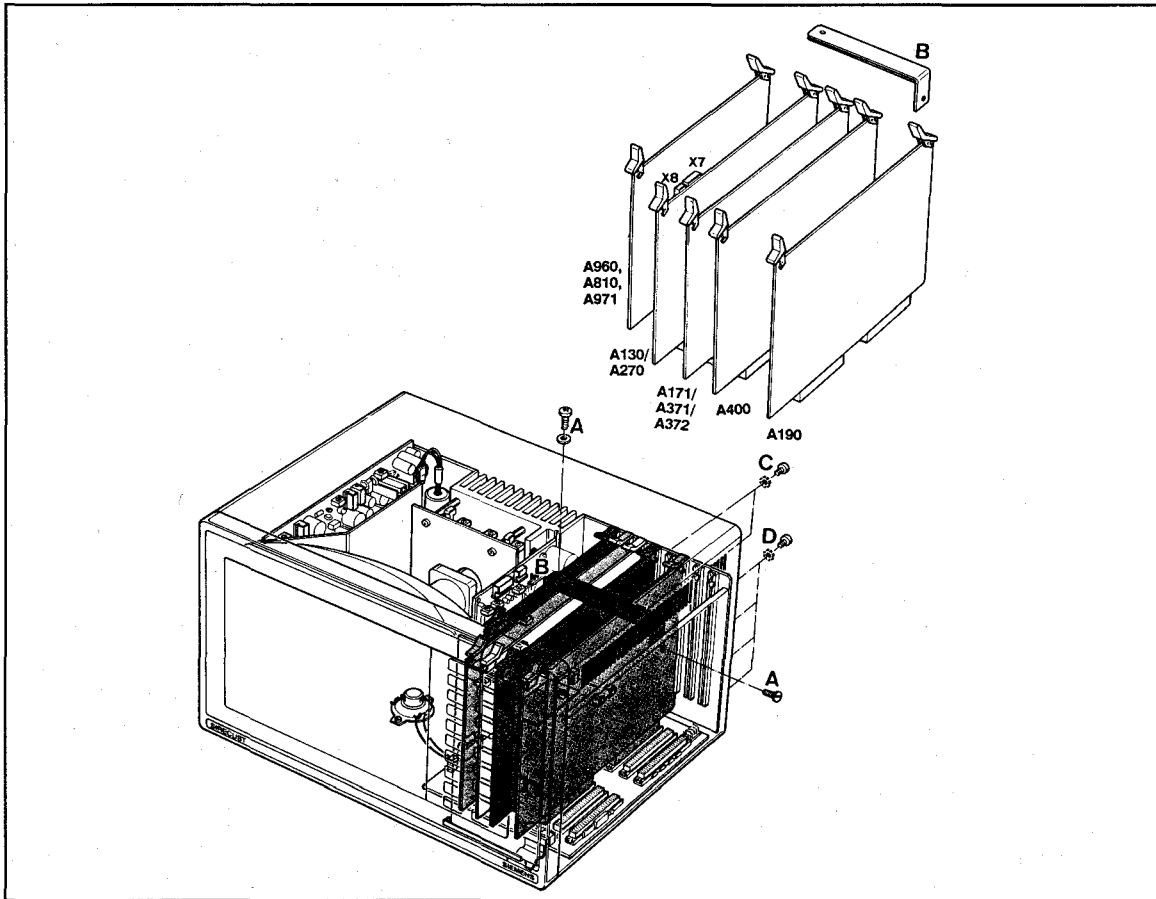

Figure 4-3. Signal Processing and Control PC Board Locations

In addition to a unique article number, each 12 inch (30 cm) board is identified by the color code of its ejectors. Its specified location in the monitor is marked with a corresponding color on the color code label on the front card support plate. The plate is attached to the front panel through standoffs, located between the plate and the component side of the Operator Interface Board, behind the front panel of the monitor. The color code is as follows:

- Curve Board: blue
- Display Processor Board: red
- Front End Board: green
- Memory Extension Board: orange

The Clock Board, Master Option Board, and 4-Ch Analog Option Board have white ejectors and are 10 inch (25 cm)

boards. Any one of them can be installed in the non-color coded 10 inch (25 cm) board position located between the holddown bar standoff and the CRT.

Positions identified by the colors violet, yellow, and white on the front card support plate are not used.

4.4. Curve Board, A130/A270

Refer to Figure 4-3.

4.4.1. Removing the Curve Board

1. Remove the outer case of the monitor following the procedure outlined in Section 4.1.1.
- 2a. Remove the Line Driver Board, if installed. Refer to Section 4.5.

- b. Remove the two Phillips-head screws (A) and washer securing the holddown bar (B) to the right side panel and to the standoff. Save the holddown bar and hardware for reassembly.
 3. Unplug connectors X7 and X8 located on the component side at the top of the Curve Board near the front of the monitor.
 4. Remove and save the two Phillips-head screws and washers (C) by X9 (SIRENET) and X10 (ALARMS) on the back of the monitor, that secure board connectors X3 and X4 to the monitor chassis.
 5. Simultaneously lift the two blue ejectors on the top front and rear corners of the board, and pull vertically on the ejectors to free the board from the Motherboard and lift it out of the monitor.
- 4.4.2. Replacing/Installing Software**
1. Remove the Curve Board following the procedure outlined in Section 4.4.1.
 2. Remove the EPROM in position J38, using an IC extractor.
 3. Carefully insert the replacement EPROM into the J38 socket, with the notch facing towards connectors X3 and X4.
 4. Firmly seat the EPROM.
 5. Reinstall the Curve Board following the procedure outlined in Section 4.4.3
- 4.4.3. Installing the Curve Board**
1. Verify the positioning of jumpers in accordance with the configuration in Appendix C.
2. Insert the board into the card guides at connectors X71 and X72 on the Motherboard, identified by the **blue** color code on the front card support plate, with the component side of the board facing the CRT.
 3. Carefully position board connectors X1 and X2 into X71 and X72 on the Motherboard.
 4. Firmly press on the ejectors to seat the Curve Board.

NOTE: The ejectors should lie flat along the top edge of the board.
 5. Insert and tighten two Phillips-head screws and washers (C) into the screw holes near X9 (SIRENET) and X10 (ALARMS) on the back of the monitor, to secure board connectors X3 and X4 to the monitor chassis.
 6. Position the holddown bar (B), and secure the bar to the right side panel and to the holddown standoff using Phillips-head screws (A) and washer.
 7. Plug X7 and X8 into their connectors at the top of the Curve Board near the front of the monitor.
 - 8a. Verify proper alignment of the display in accordance with procedures outlined in Chapter 5. See Chapter 7 if adjustment is needed.
 - b. Install the Line Driver Board as required. Refer to Section 4.5.
 9. Close the monitor following the procedure outlined in Chapter 4, Section 4.1.2.
- 4.5. Line Driver Board, A300**
- A Line Driver Board is installed only if a SIRECUST 120S/121S Remote Display

unit is to be connected to the monitor. Refer to Chapter 3, Section 3.18 for additional information. Figure 4-4 illustrates the location of the board.

4.5.1. Removing a Line Driver Board

1. Remove the outer case of the monitor following the procedure outlined in Section 4.1.1.
2. Unplug connectors X7 and X8 from the Line Driver Board.
3. Remove the screw securing the board to the monitor board hold-down bar, and the two mounting screws and washers securing the wire harness D connector to position X3 on the back of the monitor. See Figure 4-4 and Figure 4-5.
4. Unplug the output wiring harness connectors from X2 and X9 on the board.

5. Lift the board up off the Curve Board to unplug it from connectors X5, X7, and X8 on the Curve Board and remove it.

4.5.2. Installing a Line Driver Board

1. Install the output wiring harness D connector on the rear of the monitor chassis at position X3. Refer to Figure 4-5.
2. Plug Line Driver Board connectors X3, X4, and X5 into Curve Board connectors X5, X7, and X8. Refer to Figure 4-4.
3. Plug display harness connectors X7 and X8 into the board.
4. Plug the output wiring harness connectors into X2 and X9 on the Line Driver Board.
5. Install the screw securing the board to the holddown bar.

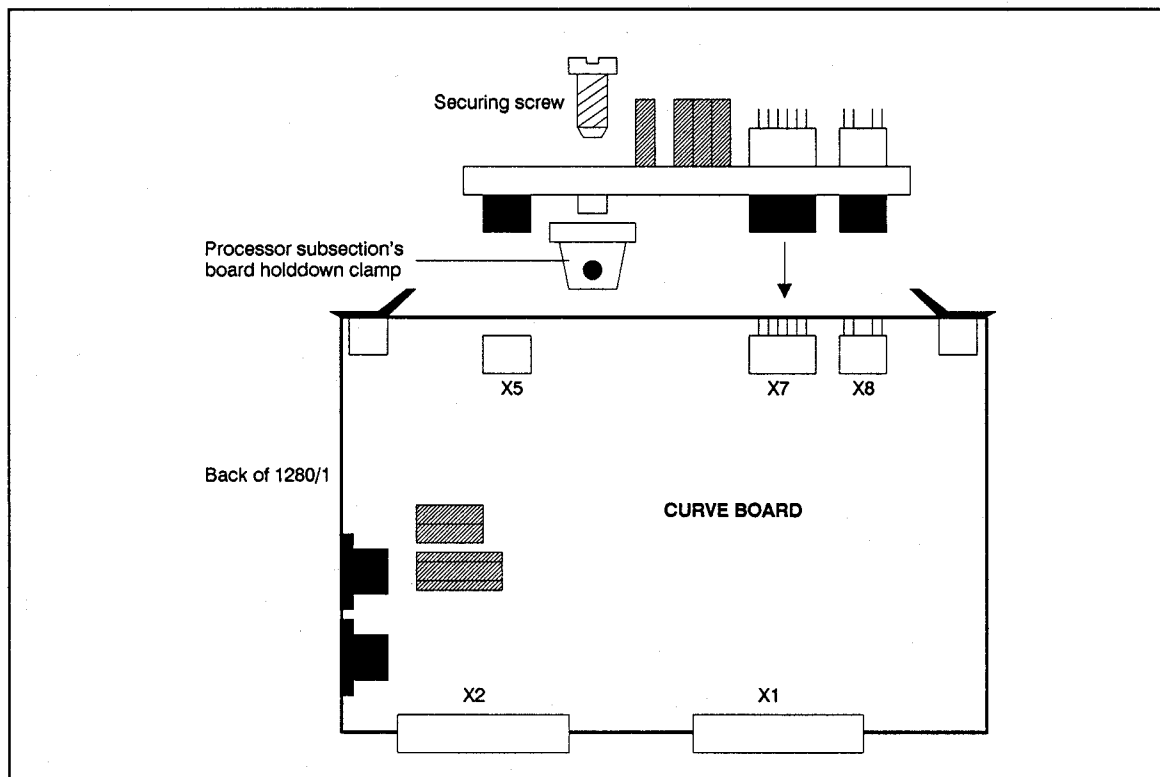

Figure 4-4. Line Driver Board Installation

System SIRECUST 1280/1281 Bedside Monitor - Service Manual

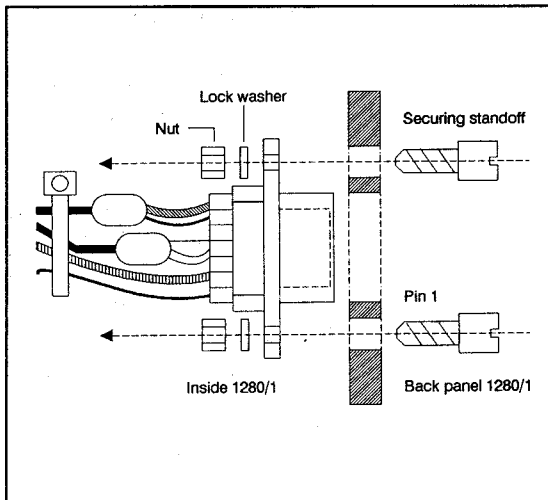

Figure 4-5. Line Driver Board D Connector Mounting Detail

6. Reassemble the monitor following the procedure outlined in Section 4.1.2.

4.6. Display Processor Board, A171/A371/A372

Refer to Figure 4-3.

4.6.1. Removing the Display Processor Board

1. Remove the outer case of the monitor following the procedure outlined in Section 4.1.1.
2. Remove the two screws (A) and washer securing the holddown bar (B) to the right side panel and to the standoff. Save the holddown bar and hardware for reassembly.
3. Simultaneously lift the two red ejectors on the top of the board, and pull vertically on the ejectors to free the board from the Motherboard and lift it out.

4.6.2. Replacing/Installing Software

1. Remove the Display Processor Board following the procedure outlined in Section 4.6.1.

2. Remove the EPROMs from J27, J28, J42, and J43 using an IC extractor.
3. Carefully insert the replacement EPROMs into the J27, J28, J42, and J43 sockets, with the notches facing towards J32 on the left center of the board.
4. Press firmly on each of the EPROMs to seat them in the sockets.
5. Reinstall the Display Processor Board following the procedure outlined in Section 4.6.3.

4.6.3. Installing Display Processor

1. Verify the positioning of jumpers in accordance with Appendix C.
2. Insert the board into the card guides for connectors X51 and X52 on the Motherboard, identified by the position of the red color code on the front card support plate, with the component side of the board facing the CRT.
3. Carefully position the board connectors X1 and X2 into X51 and X52 on the Motherboard.
4. Firmly seat the board.

NOTE: The ejectors should lie flat along the top edge of the board.

5. Position the holddown bar (B), and secure it to the right side panel and standoff using Phillips-head screws (A) and washer.
6. Close the monitor following the procedure outlined in Section 4.1.2.

4.7. Front End Board, A190

Refer to Figure 4-3.

4.7.1. Removing the Front End Board

1. Remove the outer case of the monitor following the procedure outlined in Section 4.1.1.
2. Remove the two Phillips-head screws (A) and washer securing the holddown bar (B) to the right side panel and to the standoff. Save the holddown bar and hardware for use in reassembly.
3. Remove and save the four Phillips-head screws and washers (D) near X16 (SIREM 1) and X17 (SIREM 2) on the back of the monitor, which secure board connectors X3 and X4 to the monitor chassis.
4. Simultaneously lift the two green ejectors on the top front and rear corners of the board and pull vertically on the ejectors to free the board from the connectors on the Motherboard and lift it out of the monitor.

4.7.2. Replacing/Installing Software

1. Remove the Front End Board following the procedure outlined in Section 4.7.1.
2. Remove the EPROMs from positions J17, J18, J33, and J34, using an IC extractor.
3. Carefully insert the replacement EPROMs into positions J17, J18, J33, and J34, with the notches facing toward connectors X3 and X4 on the left side of the board.
4. Firmly press on each of the EPROMs to seat them in their sockets.
5. Reinstall the Front End Board following the procedure outlined in Section 4.7.3.

4.7.3. Installing Front End Board

1. Verify the setting of jumpers in accordance with the configuration given in Appendix C.
2. Insert the board into the card guides for connectors X11 and X12 on the Motherboard, identified by the **green** color code on the front card support plate, with the component side of the board facing the CRT.
3. Carefully position board connectors X1 and X2 into X11 and X12 on the Motherboard.
4. Press on the ejectors to firmly seat the board.

NOTE: The ejectors should lie flat along the top edge of the board.
5. Secure connectors X16 (SIREM 1) and X17 (SIREM 2) to the chassis using Phillips-head screws and washers (D).
6. Position the holddown bar (B), and secure it to the right side panel and standoff using Phillips-head screws (A) and washer.
7. Close the monitor following the procedure outlined in Section 4.1.2.

4.8. Memory Extension Board, A400

Refer to Figure 4-3.

4.8.1. Removing the Memory Extension Board

1. Remove the outer case of the monitor following the procedure outlined in Section 4.1.1.
2. Remove the two Phillips-head screws (A) and washer securing the holddown bar (B) to the right

side panel and to the holddown standoff. Save the holddown bar and hardware for reassembly.

3. Simultaneously lift the two **orange** ejectors on the top front and rear corners of the board and pull vertically on the ejectors to free the board from its connectors on the Motherboard and lift it out.

4.8.2. Replacing/Installing Software

1. Remove the Memory Extension Board following the procedure outlined in Section 4.8.1.
2. Remove the EPROMs from J17, J18, J33, and J34.
3. Carefully insert the replacement EPROMs into positions J17, J18, J33, and J34, with the notches facing towards jumper sockets X7, X8, X6, and X12.
4. Firmly press on the EPROMs to seat them in their sockets.
5. Reinstall the Memory Extension Board following the procedure outlined in Section 4.8.3.

4.8.3. Installing the Memory Extension Board

1. Verify the positioning of jumpers in accordance with Appendix C.
2. Insert the board into the card guides for connectors X31 and X32 on the Motherboard, identified by the **orange** color code on the card support plate, with the component side of the board facing towards the CRT.
3. Carefully position the board connectors X1 and X2 into X31 and X32 on the Motherboard, and press on the ejectors to seat the board.

NOTE: The ejectors should lie flat along the top edge of the board.

4. Position the holddown bar (B), and secure it to the right side panel and standoff using Phillips-head screws (A) and washer.
5. Close the monitor following the procedure outlined in Section 4.1.2.

4.9. Clock Board, A960, Master Option Board, A810, or 4-Ch Analog Option Board, A971

NOTE: The Clock Board is used in standalone installations of monitors, in place of the clock normally available when the monitor is connected into a SIRENET network.

Refer to Figure 4-3.

4.9.1. Removing the Clock Board, Master Option Board, or 4-Ch Analog Option Board

1. Remove the outer case of the monitor following the procedure outlined in Section 4.1.1.
2. Remove the Phillips-head screws (A) and washer securing the holddown bar (B) to the right side panel and to the holddown standoff. Save the screws and holddown bar.
3. Remove and save any Phillips-head screws and washers located in the rear chassis between connectors X5-X6 and X7-X8.
4. Simultaneously lift the two **white** ejectors on the top front and rear corners of the Clock Board, Master Option Board, or 4-Ch Analog Option Board, and pull vertically on the ejectors to free the board from its connectors and lift it out of the monitor.

4.9.2. Replacing/Installing Software on the Master Option Board

1. Remove the Master Option Board following the procedure outlined in Section 4.9.1.
2. Remove the EPROM from J23 using an IC extractor.
3. Carefully insert the replacement EPROM into position J23, with the notche facing toward connectors X3, X4, X5, and X6 on the left side of the board.
4. Firmly press on the EPROM to seat it in the socket.
5. Reinstall the Master Option Board following the procedure outlined in Section 4.9.5.

4.9.3. Activating/Deactivating MOB Backup Battery

Refer to Figure 4-6.

1. Remove the Master Option Board following the procedure outlined in Section 4.9.1.
 - 2a. To activate battery back-up, remove jumper X7 from between pins 1 and 2, and install it between pins 2 and 3.
 - b. To de-activate battery back-up, remove jumper X7 from between pins 2 and 3, and install it between pins 1 and 2.

NOTE: Always return jumper X7 to the inactive state (between pins 1 and 2) when the board is not in service.

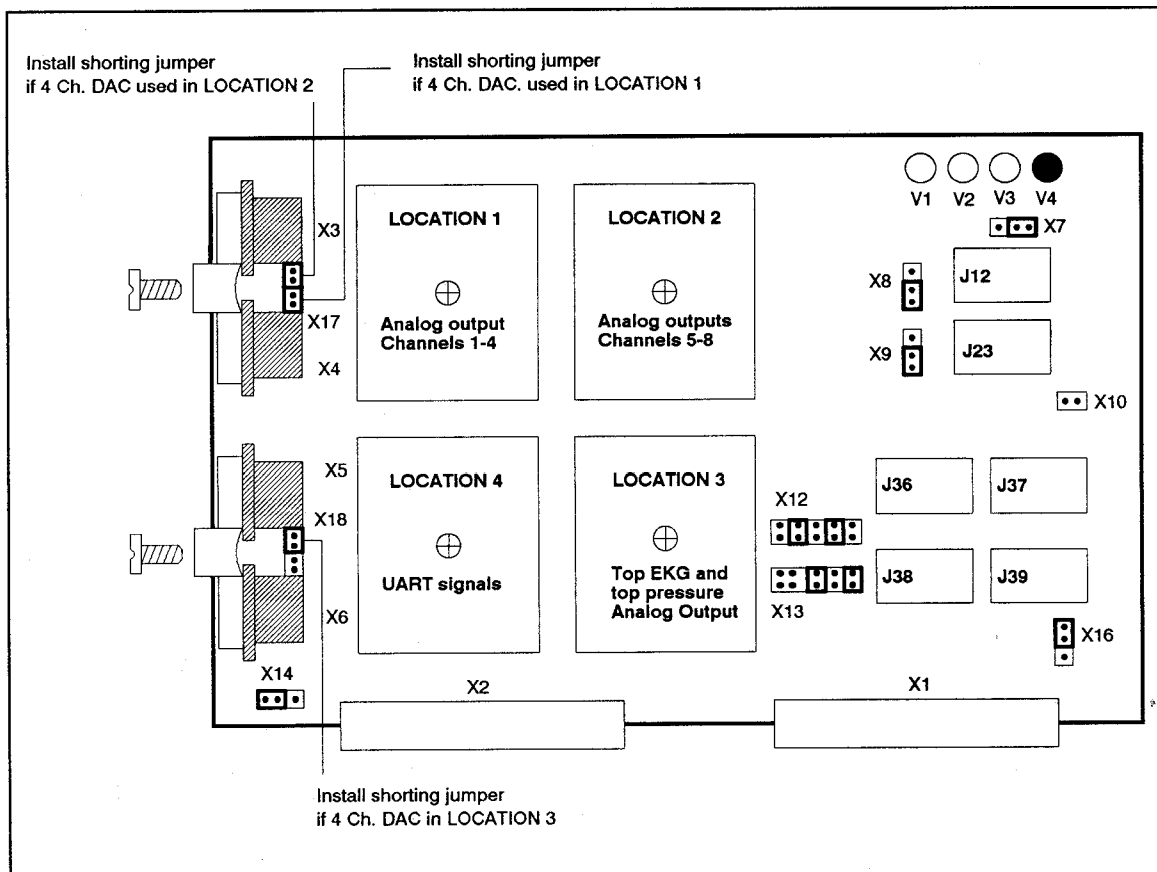

Figure 4-6. Master Option Board Configuration

3. Reinstall the Master Option Board following the procedure outlined in Section 4.9.5.

4.9.4. Installing Sub-Option Boards (SOB)

Refer to Figure 4-6 for locations of specific sub-option boards.

CAUTION: Use extreme care and properly orient the sub-option board when installing it on a Master Option Board. The male pins and receiving female connectors are the same for each corner.

1. Remove the MOB following the procedure outlined in Section 4.9.1.
2. Orientate the SOB to align the securing screw hole with the hole on the MOB, and the male connectors with the sockets.
3. Gently seat the board and secure it to the MOB with a screw.

NOTE: Do not remove the protective mylar shield covering the solder side of the board.

4. Install activation jumper as noted in Figure 4-6.
5. Reinstall the MOB following the procedure outlined in Section 4.9.5.

4.9.5. Installing the Clock Board, Master Option Board, or 4-Ch Analog Option Board

1. Verify the positioning of any jumpers in accordance with the configuration given in Appendix C.
2. Insert the board into the card guides for connectors X81 and X82 on the Motherboard, located between the board holddown

standoff and the CRT, with the component side of the board facing in the direction of the CRT.

3. Carefully position the board connectors X1 and X2 into X81 and X82 on the Motherboard, and press on the ejectors to seat the board.

NOTE: The ejectors should lie flat along the top edge of the board.

4. Position the holddown bar, and secure the bar to the right side panel and to the board holddown standoff using Phillips-head screws and washer.
- 5a. Go to Step 9 if installing a Clock Board.
- b. Go to Step 8 if installing an Analog Option Board.
- c. Insert and tighten Phillips-head screws with washers into holes near X5 and X7 on the rear chassis, to secure board connectors X3-X4 and X5-X6.
7. Go to Step 9.
8. Insert and tighten a Phillips-head screw and washer into screw hole near X7, to secure board connector X3 to the chassis.
9. Close the monitor following the procedure outlined in Section 4.1.2.

4.10. Deflection Board, A160/A310

Refer to Figure 4-7.

4.10.1. Removing the Deflection Board

1. Remove the outer case of the monitor following the procedure outlined in Section 4.1.1.

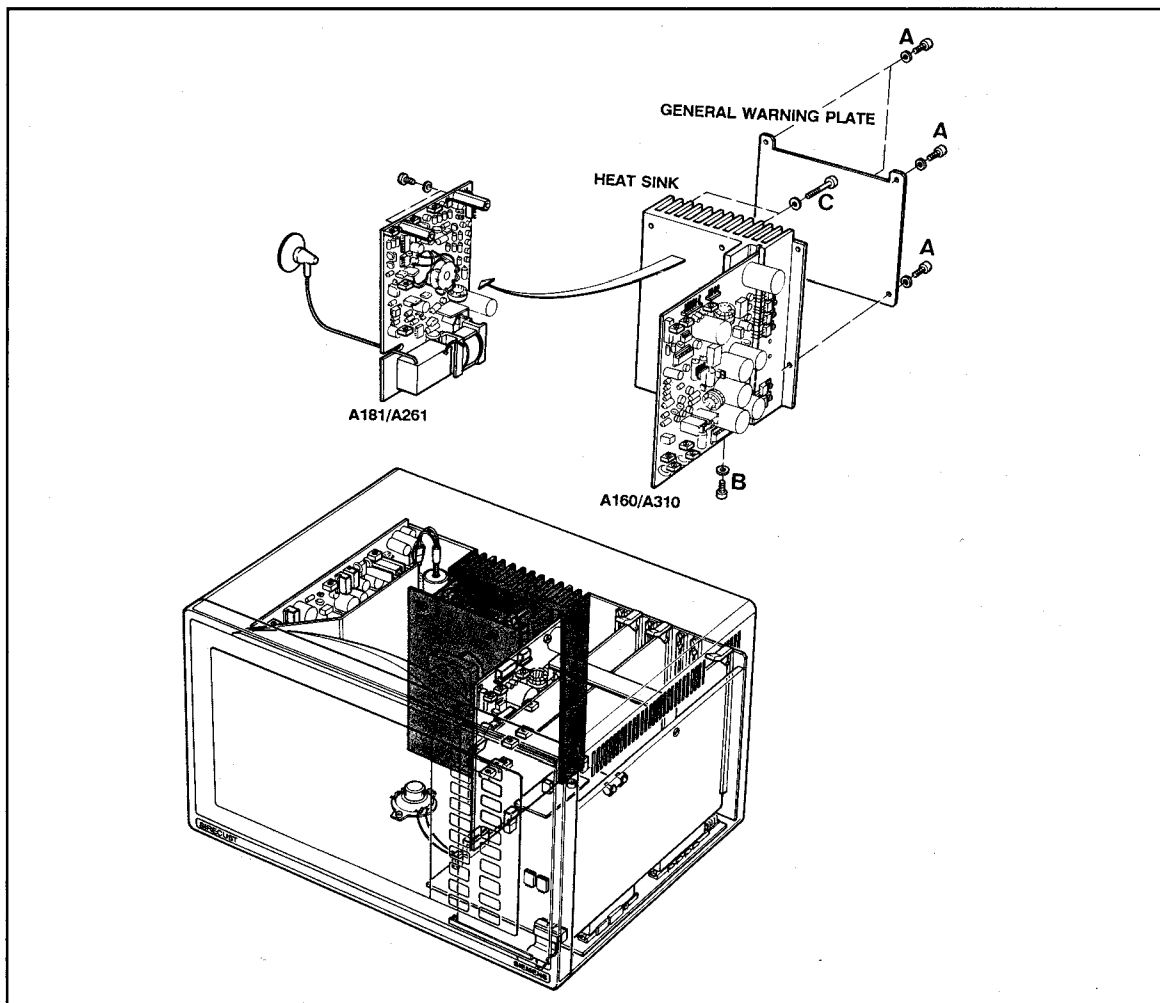

Figure 4-7. Location of Deflection Boards, A160/A310, and Z-Amp Boards, A181/A261

2. Unplug connectors X2 and X3 located on the top edge of the component side of the Deflection Board.
3. Unplug the connector located at the top edge on the back side of the board, identified as connector X5 on 1280 monitors and as connector X4 on 1281 monitors.
4. Unplug the connector located in the center of the back side of the Deflection Board, identified as connector X4 on 1280 monitors and as X1 on 1281 monitors.
5. Remove the four screws and washers securing the General

Warning Plate and the Deflection Board heat sink to the monitor chassis. Save the Warning Plate and hardware for reassembly.

NOTE: Some monitors have a fifth screw and washer securing the heat sink to the bottom of the chassis. Also remove and save these if installed.

6. Remove and save the two screws and washers located between the cooling fins near the top of the Deflection Board heat sink which secure the heat sink to the Z-Amp Board standoffs.

NOTE: The heat sink is an integral part of the Deflection Board. Do NOT

attempt to separate the heat sink from the board.

7. Lift the Deflection Board and heat sink vertically out of the monitor.

4.10.2. Installing the Deflection Board

1. Verify the positioning of jumpers in accordance with the configuration given in Appendix C.
2. Carefully lower the board and heat sink assembly into position on the rear monitor chassis, so that the four mounting holes in the heat sink align with the mounting holes in the chassis.

NOTE: Be sure the Z-Amp Board is installed before installing the Deflection Board.

3. Insert two screws and washers into the mounting holes located between the cooling fins at the top of the heat sink, and tighten the screws to secure the Z-Amp Board standoffs to the Deflection Board.
4. Position the General Warning Plate and the Deflection Board heat sink so that the four mounting holes in the plate and the board line up properly with the mounting holes in the rear of the monitor chassis.
5. Insert four Phillips-head screws with washers into the mounting holes, and tighten the screws to secure the plate and heat sink to the monitor chassis.

NOTE: Reinstall the fifth screw and washer securing the heat sink to the bottom of the chassis, if one was present in the original installation.

6. Plug X4 (1280) or X1 (1281) into its connector located in the center

of the back side of the Deflection Board.

7. Plug X2 and X3 into their connectors located at the top edge on the component side of the Deflection Board.
8. Plug X5 (1280) or X4 (1281) into its connector at the top edge on the back side of the board.
9. Verify proper alignment of the display in accordance with procedures outlined in Chapter 5, and adjust as required following procedures outlined in Chapter 7.
10. Close the monitor following the procedure outlined in Chapter 4, Section 4.1.2.

4.11. Z-Amp Board, A181/A261

Refer to Figure 4-7.

4.11.1. Removing the Z-Amp Board

1. Remove the outer case of the monitor following the procedure outlined in Section 4.1.1.
2. Remove the Deflection Board following procedures of Section 4.10.1.
3. Unplug connectors X1, X2, and X3, at the top on the component side of the Z-Amp Board, and X4, located below X3 on the component side of the board near the CRT shield.
4. Unplug the high-voltage anode connector located on the left side of the CRT.
5. Unplug the 7-pin socket connector from the neck of the CRT.
6. Unplug the wire connecting the conductive coating on the outside

of the CRT to chassis ground, at the grounding lug on the the board near the neck of the CRT.

7. Carefully lift the board up out of the card guide on the monitor chassis, and then slide the board towards the rear of the monitor to free it from the neck of the CRT.
8. Remove the board from the monitor.

NOTE: Be careful to NOT bend the connector pins on the CRT.

4.11.2. Installing the Z-Amp Board

1. Carefully slide the board over the neck of the CRT, and position the board into the card guide on the bottom of the chassis.

NOTE: The Deflection Board with heat sink must be removed to install the Z-Amp Board.

2. Attach the ground wire, from the conductive coating on the outside of the CRT to chassis ground, to the grounding lug located on the back side of the board near the neck of the CRT.
3. Plug the 7-pin socket connector into the CRT.
4. Plug the high-voltage connector into the high-voltage anode on the left side of the CRT.
5. Plug X1, X2, and X3 into their connectors located at the top on the component side of the Z-Amp Board, and X4 to its connector located below X3 on the component side of the board near the CRT shield.
6. Measure the high-voltage present at the anode of the CRT and adjust if required. See Chapter 7.

7. Complete the procedure outlined in Section 4.10.2. to reinstall the Deflection Board and reassemble the monitor.

4.12. Operator Interface Board, A291/A292

Refer to Figure 4-8.

4.12.1. Removing the Operator Interface Board

1. Remove the outer case of the monitor following the procedure outlined in Section 4.1.1.
2. Remove the Front Panel following the procedure outlined in Section 4.17.3.
3. Remove all PC boards installed in the 12 inch (30 cm) section of the monitor. Refer to procedures of Sections 4.4.1, 4.6.1, 4.7.1, and 4.8.1.

NOTE: It is not necessary to remove any PC board (Clock Board, Master Option Board, or 4-Ch Analog Option Board) installed in the 10 inch (25 cm) section adjacent to the CRT.

4. Unplug the ribbon cable from connector X7 on the Motherboard.
5. Remove the four Phillips-head screws, washers, and standoffs, securing the card support plate and Operator Interface Board to the monitor chassis. Save the card support plate and hardware for reassembly.
6. Lift the board out of the guide and up out of the monitor.

4.12.2. Replacing/Installing Software

NOTE: To replace or install software in the Operator Interface Board, it is not necessary to remove the board from the

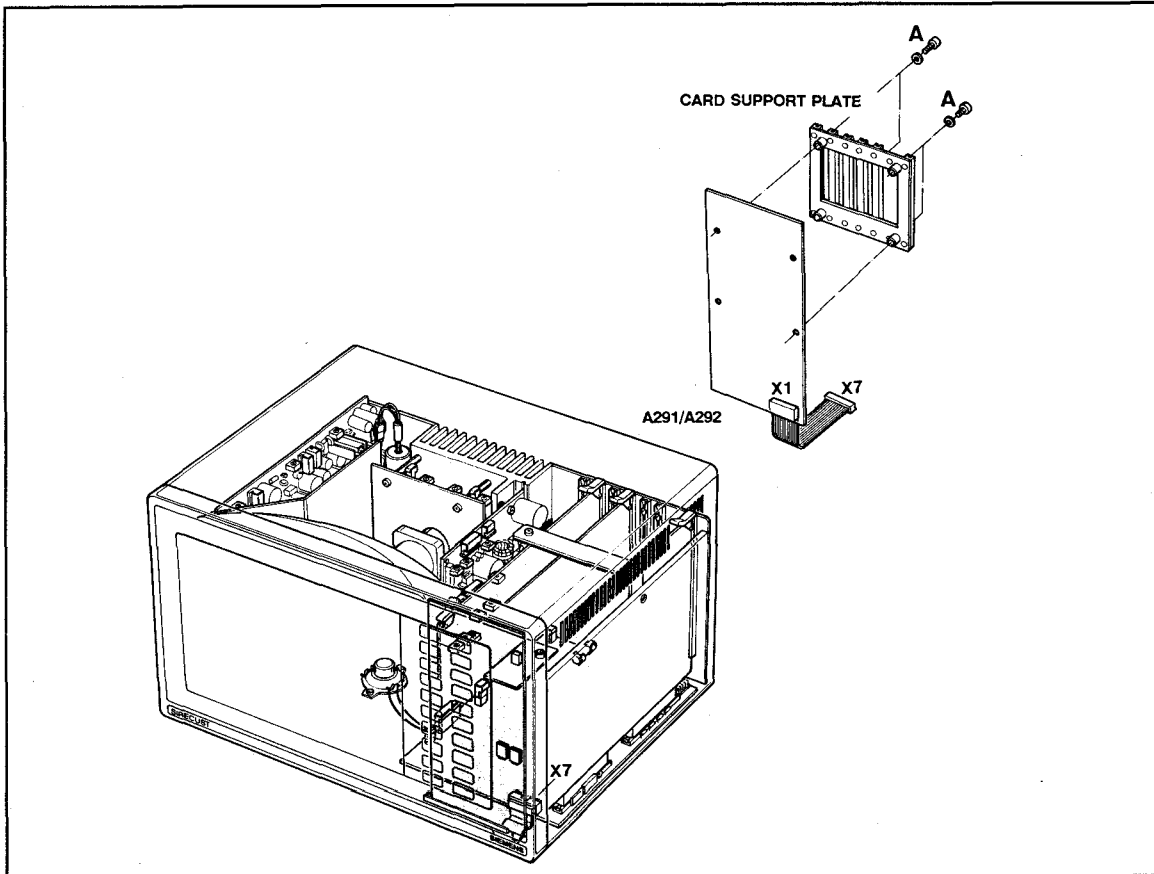

Figure 4-8. Location of Operator Interface Board, A291/A292, and Card Support Plate

monitor. The software EPROM is easily accessed after removal of the Display Processor and Memory Extension Boards.

1. Remove the Display Processor and Memory Extension Boards following the procedures of Sections 4.6.1. and 4.8.1.
2. Remove the card guides on the front card support plate from positions color coded red, yellow, and orange, to access the EPROM in socket J9 on the board.
3. Remove the EPROM from J9 using an IC extractor.
4. Carefully insert the replacement EPROM into the J9 IC socket, with the notch facing towards the left side of the board.

5. Firmly seat the EPROM.

6. Reinstall the Display Processor and Memory Extension Boards following the procedures of Sections 4.6.3. and 4.8.3.

4.12.3. Installing the Operator Interface Board

1. Position the board into its card guide on the monitor chassis at the front of the 12 inch (30 cm) section, so that the four mounting holes in the Board align with the mounting holes in the chassis.
2. Secure the card support plate and the Operator Interface Board to the monitor chassis using Phillips-head screws and washers (A). Use the standoffs referenced in

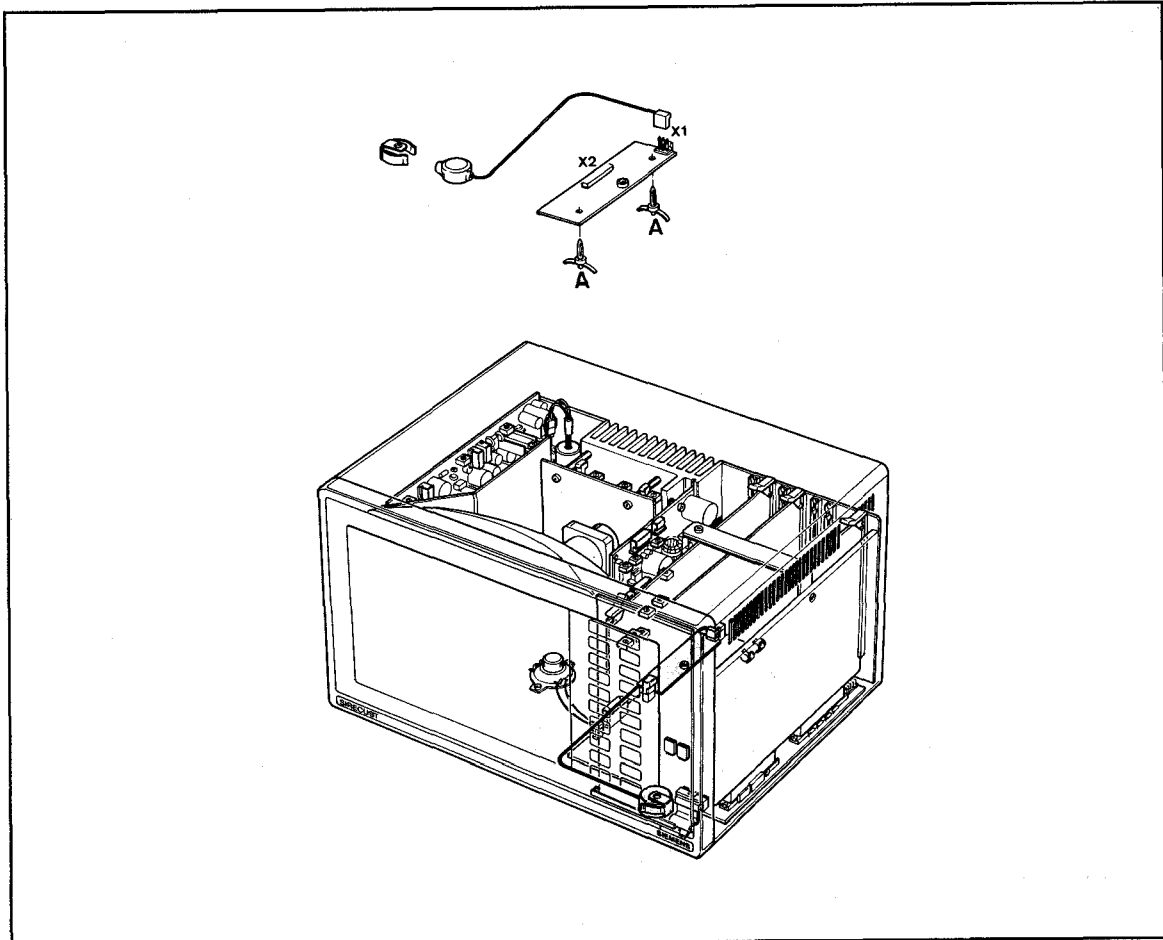

Figure 4-9. Location of Battery Board, A931, or Memory Backup Board, A933

Section 4.12.1, Step 5 to separate the plate from the board.

3. Plug the ribbon cable connector into X7 on the Motherboard near front of the chassis.
4. Reinstall all PC boards into the color coded 12 inch (30 cm) PC board section of the monitor, following the procedures outlined in Sections 4.4.3, 4.6.3, 4.7.3, and 4.8.3.
5. Reinstall the Front Panel following the procedure outlined in Section 4.17.3.
6. Reinstall the outer case of the monitor following the procedure outlined in Section 4.1.2.

4.13. Battery Board, A931, or Memory Backup Board, A933

NOTE: Monitors may be equipped with either of the two boards, located in the same position in the monitor. The A933 Memory Backup Board replaces the A931 Battery Board.

Refer to Figure 4-9.

4.13.1. Removing Battery Board or Memory Backup Board

1. Remove the outer case of the monitor following the procedure outlined in Section 4.1.1.
2. Remove the Deflection Board following the procedure outlined in Section 4.10.1.

3. Remove the Z-Amp Board following the procedure outlined in Section 4.11.1.
4. Press the locking tabs in on each board mount (A), and carefully lift on the Battery Board or Memory Backup Board to free it from the Motherboard.

NOTE: The connector interfacing the Battery Board or Memory Backup Board to the Motherboard automatically disconnects when the board is lifted off the Motherboard.

NOTE: For monitors equipped with a Battery Board, unplug harness connector X1 (3-prong connector) from JP1 on the component side of the board near the rear of the monitor chassis.

4.13.2. Installing the Battery Board or Memory Backup Board

1. Position the board to align the mounting holes with the locking mounts (A) on the Motherboard, and board connector X2 with the pins of the connector on the Motherboard.
2. Carefully press down on the Battery Board or Memory Backup Board to seat it on the mounts and complete the interface with the Motherboard.

NOTE: Reconnect battery harness connector X1 (3-prong) to JP1 on the Battery Board if the monitor is equipped with a nicad battery.

3. Reinstall the Z-Amp Board following the procedure outlined in Section 4.11.2.
4. Complete the procedure outlined in Section 4.10.2. to reinstall the Deflection Board and reassemble the monitor.

4.14. Nicad Battery Subassembly

NOTE: Some monitors use a nicad battery connected to the Battery Board, to provide energy for the memory backup circuitry. The battery is a separate subassembly mounted on the chassis near the Operator Interface Panel, with a two-wire harness that plugs into JP1 on the Battery Board.

Refer to Figure 4-9.

4.14.1. Removing the Nicad Battery Subassembly

1. Remove the outer case of the monitor following the procedure outlined in Chapter 4, Introduction and Section 4.1.1.
2. Remove the Deflection Board following the procedure outlined in Section 4.10.1.
3. Remove the Curve Board, Display Processor Board, Memory Extension Board, and Clock Board, Master Option Board, or 4-Ch Analog Option Board using procedures outlined in Sections 4.4.1, 4.6.1, 4.8.1, and 4.9.1.

NOTE: Note the dress of the battery wiring harness for reference when reinstalling or replacing the battery subassembly.

4. Slide the nicad battery out of the battery holder, and carefully remove the battery subassembly from the monitor.

4.14.2. Installing the Nicad Battery Subassembly

1. Position the nicad battery subassembly on the bottom of the chassis near the battery holder, and connect the wire harness connector to JP1 on the Battery Board.

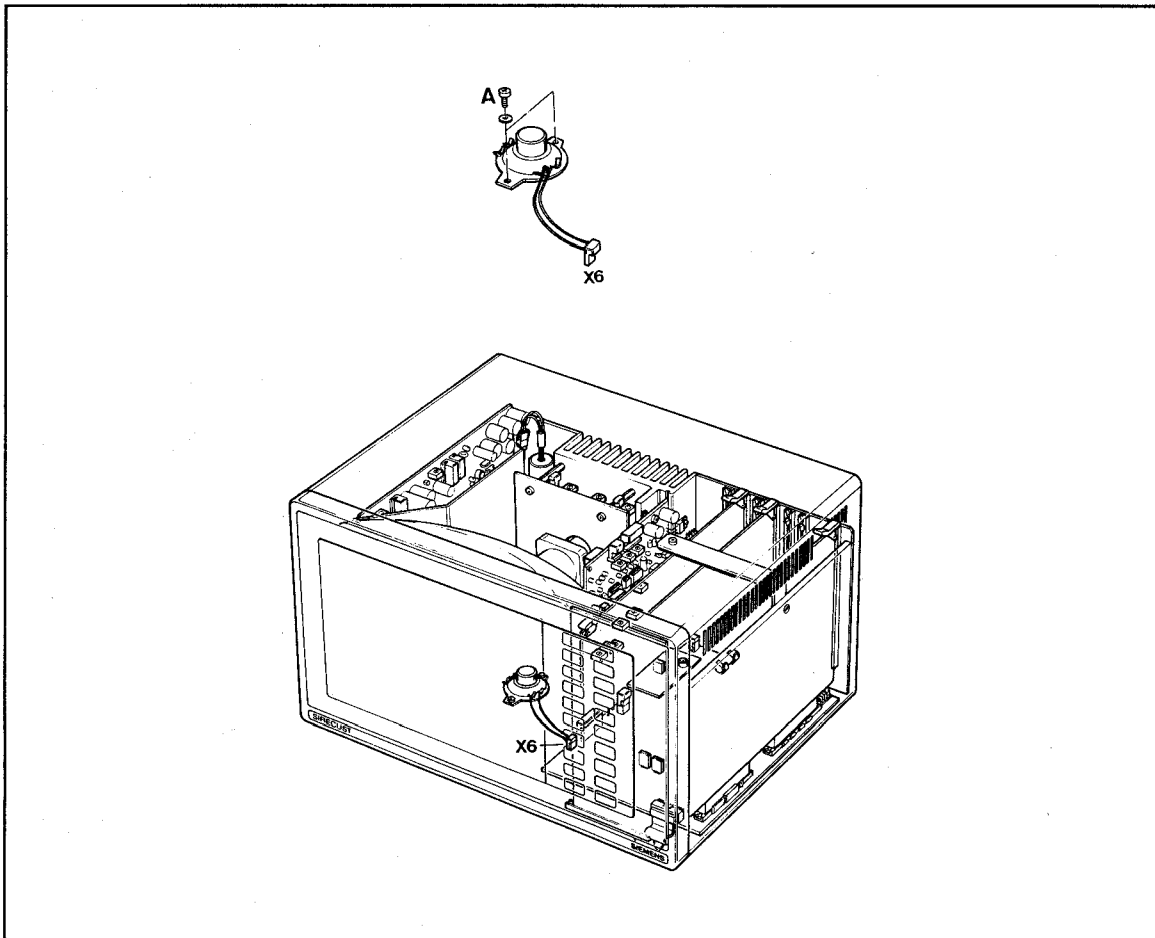

Figure 4-10. Location of Speaker Assembly

NOTE: Dress the wire harness from the battery assembly along the bottom of the monitor chassis around the Battery Board so that harness connector, X1, can be plugged into board connector JP1 without producing any strain on the wires or on JP1.

2. Slide the battery into the holder.
3. Reinstall the Curve Board, Display Processor Board, Memory Extension Board, and any Option Board originally installed, using procedures outlined in Sections 4.4.3, 4.6.3, 4.8.3, and 4.9.5.
4. Complete the procedure outlined in Section 4.10.2. to reinstall the Deflection Board and reassemble the monitor.

4.15. Speaker Assembly

Refer to Figure 4-10.

4.15.1. Removing the Speaker Assembly

1. Remove the outer case of the monitor following the procedure outlined in Section 4.1.1.
2. Remove the Deflection Board following the procedure outlined in Section 4.10.1.
3. Remove the Z-Amp Board following the procedure outlined in Section 4.11.1.
4. Unplug speaker connector X6 from the Motherboard.

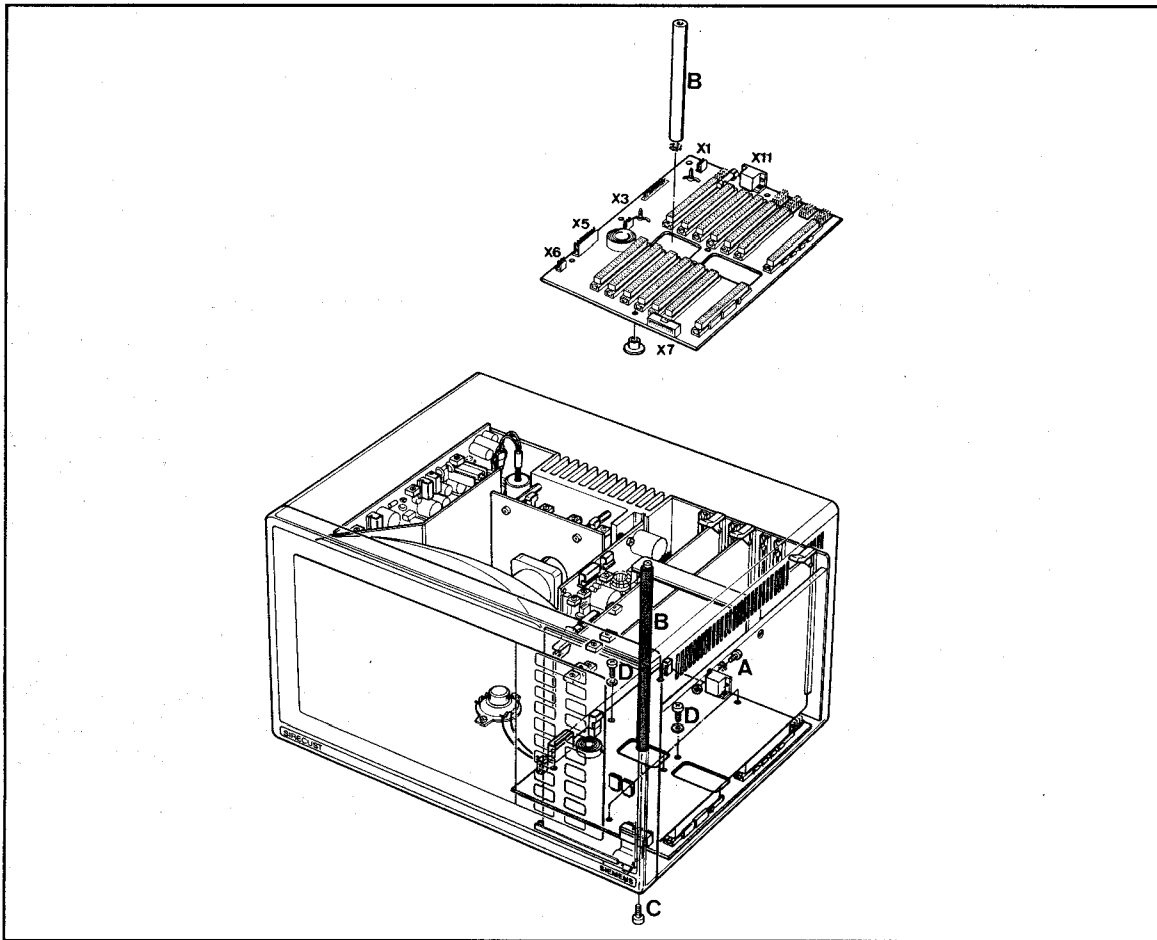

Figure 4-11. Location of Motherboard

5. Remove the two Phillips-head screws and washers (A) securing the speaker assembly to the chassis.
6. Remove the speaker assembly from the monitor.

4.15.2. Installing the Speaker Assembly

1. Plug speaker connector into connector X6 on the Motherboard.
2. Position the speaker so that the mounting holes in the speaker frame align with the mounting holes in the chassis.
3. Insert Phillips-head screws with washers (A) into the two mounting

holes in the speaker frame, and tighten the screws to secure the speaker to the monitor chassis.

4. Complete the procedure outlined in Section 4.11.2. to reinstall the Z-Amp Board and reassemble the monitor.

4.16. Motherboard, A100

Refer to Figure 4-11.

4.16.1. Removing the Motherboard

1. Remove the outer case of the monitor following the procedure outlined in Section 4.1.1.
2. Remove all PC boards from the 12 inch (30 cm) and 10 inch (25 cm)

board sections, following procedures outlined in Sections 4.4.1, 4.6.1, 4.7.1, 4.8.1, and 4.9.1.

3. Remove the Memory Backup Board following the procedure outlined in Section 4.13.1.
4. Unplug connectors X1, X3, X5, X6, and X7 on the Motherboard.
5. Remove the Phillips-head screw securing X11 (A) on the Motherboard to the back of the chassis.
6. Remove the 7 Phillips-head screws and washers (D) securing the Motherboard to the monitor chassis.
7. Lift the side of the Motherboard near the CRT, slightly, and move it towards the CRT to free it from the channel in the side panel.

8. Lift the Motherboard out.

4.16.2. Installing the Motherboard

1. Verify the positioning of jumpers JP1, JP2, JP3, JP4, JP8, and JP90 in accordance with the configuration given in Appendix C.
2. Locate the Motherboard on the bottom of the chassis so that the edge of the board near connectors X11 and X12 is seated in the groove in the right side panel, and the seven holes for the mounting screws are aligned with the mounting holes in the bottom of the chassis.
3. Insert Phillips-head screws with washers (D) into the seven mounting holes, and tighten the screws to secure the Motherboard to the monitor chassis. See Figure 4-11.

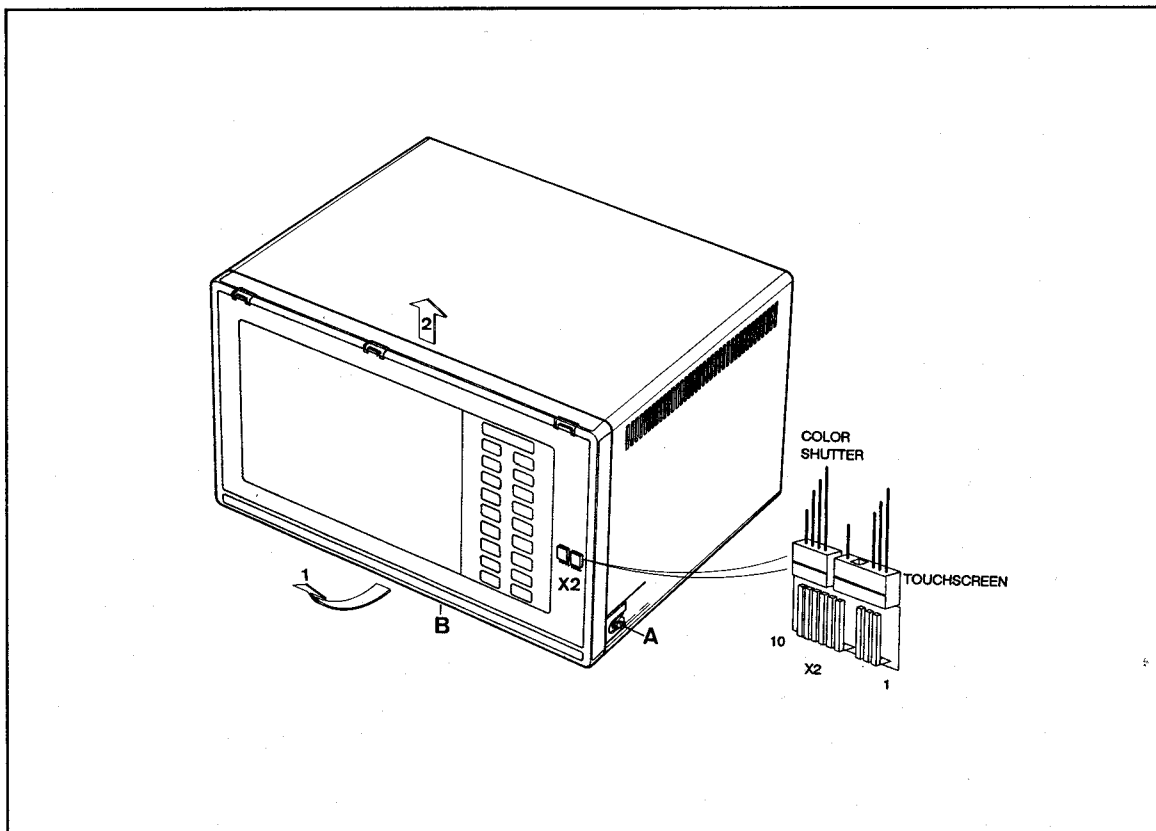

Figure 4-12. Front Panel Subassembly

4. Insert a Phillips-head screw with washer (A) into the mounting hole by the position for X11 on the monitor chassis, and tighten the screw to secure X11 on the Motherboard to the back of the chassis.
5. Plug X1, X3, X5, X6, and X7 into their connectors on the Motherboard.
6. Complete the procedure outlined in Section 4.13.2. to reinstall the Memory Backup Board and reassemble the monitor.

4.17. Front Panel Subassembly

NOTE: For servicing purposes, the Front Panel Subassembly is considered to consist of the TouchScreen/Front Panel, the Front Frame (containing the Color Shutter in SIRECUST 1281 monitors), a language label, and name strip.

Refer to Figure 4-12.

4.17.1. Replacing the Name Strip

NOTE: The Name Strip is located on the front outside surface near the bottom of the Front Frame.

1. Carefully lift the right side edge of the Name Strip using a knife or other sharp instrument.
2. Slowly peel the label off the frame.
3. Remove the backing from the replacement label.
4. Carefully place one end of the replacement label into position at the bottom front of the frame, and apply pressure along the label with a sweeping or rolling motion to cause the label to adhere to the frame and prevent air bubbles from becoming trapped under the label.

NOTE: Do NOT let the label touch the frame ready to be pressed into place. The label adheres on contact.

4.17.2. Removing the Front Panel Subassembly

1. Remove the outer case following the procedure outlined in Section 4.1.1.
2. Remove and save the two screws and washers (A) which secure the front panel frame to the chassis near the bottom on each side of the frame.
3. Pull forward (1) on the bottom corners of the frame until it separates from the chassis.
4. Carefully lift (2) the Front Panel Subassembly to free the top of the frame from the chassis.

NOTE: Some monitors have a third screw and washer (B) securing the Front Panel Subassembly to the bottom chassis. Also remove and save this screw and washer if installed.

CAUTION: The connector (X2) for the cables from the TouchScreen and Color Shutter (on 1281 monitors) to the Operator Interface Board is located behind the front panel on the right hand side of the monitor. The cables are short and can be easily damaged if the subassembly is lifted too far off the top of the chassis before disconnecting the cables.

5. Carefully tilt the top of the subassembly slightly forward to access the Operator Interface Board connector plug, X2.
6. Disconnect the wiring harness plugs from the TouchScreen and Color Shutter (1281 monitor) at connector X2 to free the Front Panel Subassembly.

4.17.3. Installing the Front Panel Subassembly

1. Hold the Front Panel Subassembly close to its position when installed on the monitor, to minimize tension on the connectors, and plug the connectors from the Touch-Screen and the Color Shutter (only on 1281 monitors) into X2 on the Operator Interface Board. Refer to Figure 4-12.
2. Tilt the subassembly slightly towards the monitor and seat the top of the frame into position on the front of the monitor.
3. Press the bottom of the frame onto the front of the monitor to seat the subassembly.

NOTE: The two mounting holes in the side of the chassis should be visible through the slots at the bottom of each side of the frame.

4. Secure the front panel to the monitor chassis using screws with washers (A) through each of the two slots into the mounting holes.
5. Reinstall the outer case of the monitor following the procedure outlined in Section 4.1.2.

4.17.4. Replacing the Language Label

NOTE: The Language Label is a plastic overlay. See Figure 4-13.

1. Carefully lift the upper left corner of the label to separate it from the panel, and **slowly** peel it off pulling diagonally towards the lower right corner. Do NOT use any sharp tools in this procedure.

CAUTION: Firmly press on the area of the TouchScreen newly exposed from under the label as you peel the label off, to avoid damaging the TouchScreen by separating the two surfaces.

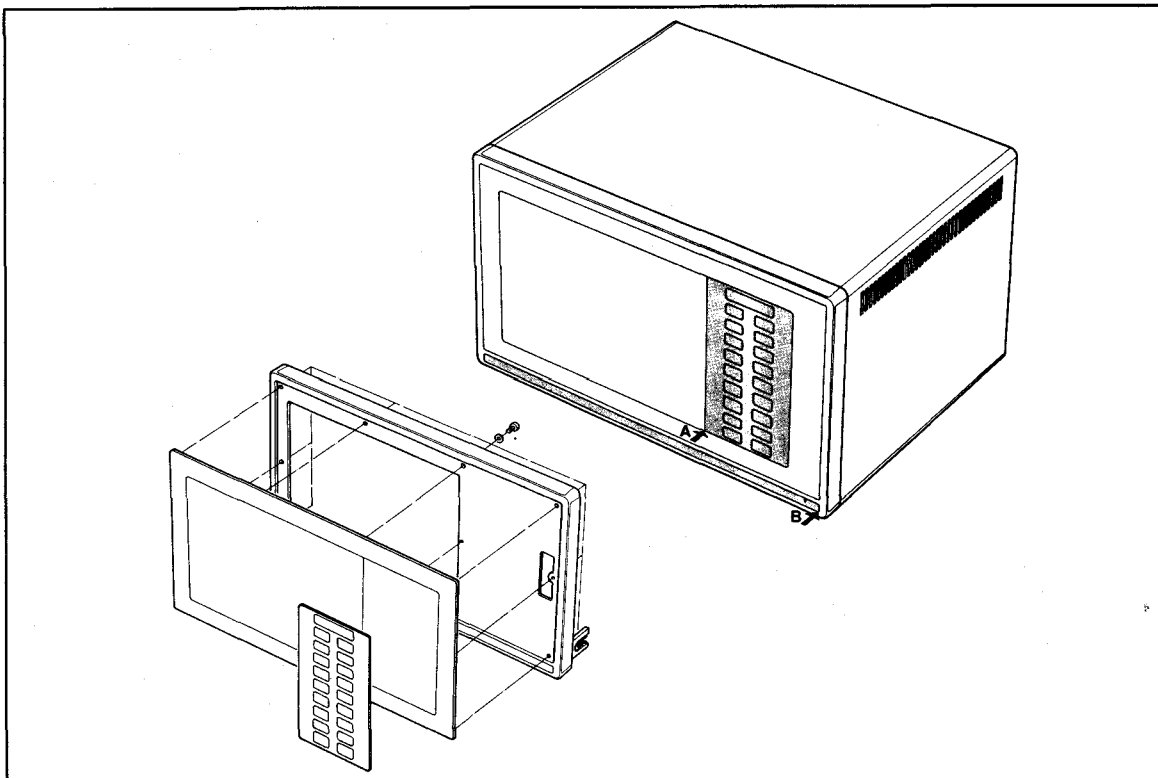

Figure 4-13. Color Shutter and Language Label

2. Peel ½ the backing off from the replacement label and fold it back on itself. Position the backed area of the label into place on the panel.

NOTE: Do NOT let any exposed adhesive touch the panel until you are ready to press the label into place. The label adheres on contact.

3. Starting in the middle where the backed area and the exposed adhesive area meet, press the label onto the panel moving outward toward the edge. Use a wiping or rolling motion to prevent air from becoming trapped under the label.
4. Remove the remaining backing and press the other ½ of the label into place using the same procedure as in Step 3.

4.18. Color Shutter (only on SIRECUST 1281 monitors)

Refer to Figure 4-13.

4.18.1. Removing the Color Shutter

NOTE: The color shutter is factory installed in the front frame.

1. Remove the Front Panel Subassembly following the procedures of Section 4.17.2.
2. Lay the subassembly face down on a soft, clean, flat surface.
3. Remove the eleven Phillips-head screws and washers (A) binding the front frame to the front panel.
4. Lift the frame off the front panel.

4.18.2. Installing the Color Shutter

1. Lay the front panel face down on a soft clean flat surface.

2. Assure that the surfaces of the front panel and color shutter are clean and free from dust.
3. Align the mounting holes in the front frame with the holes in the front panel.
4. Insert Phillips-head screws with washers (A) into the mounting holes, and tighten the screws to secure the frame to the panel.
5. Reinstall the Front Panel Subassembly following procedures outlined in Section 4.17.3.

4.19. CRT

NOTE: The CRT mounting bracket and deflection yoke are factory installed on the CRT.

Refer to Figure 4-14.

4.19.1. Removing the CRT

1. Remove the outer case of the monitor following the procedure outlined in Section 4.1.1.
2. Remove the Deflection Board and Z-Amp following the procedures outlined in Sections 4.10.1. and 4.11.1.
3. Remove the Curve Board following the procedure outlined in Section 4.4.1.
4. Remove any installed Option Board following the procedure outlined in Section 4.9.1.
5. Remove the Power Supply Board following the procedure outlined in Section 4.2.1.
6. Position the monitor face down on a clean, soft, flat surface.

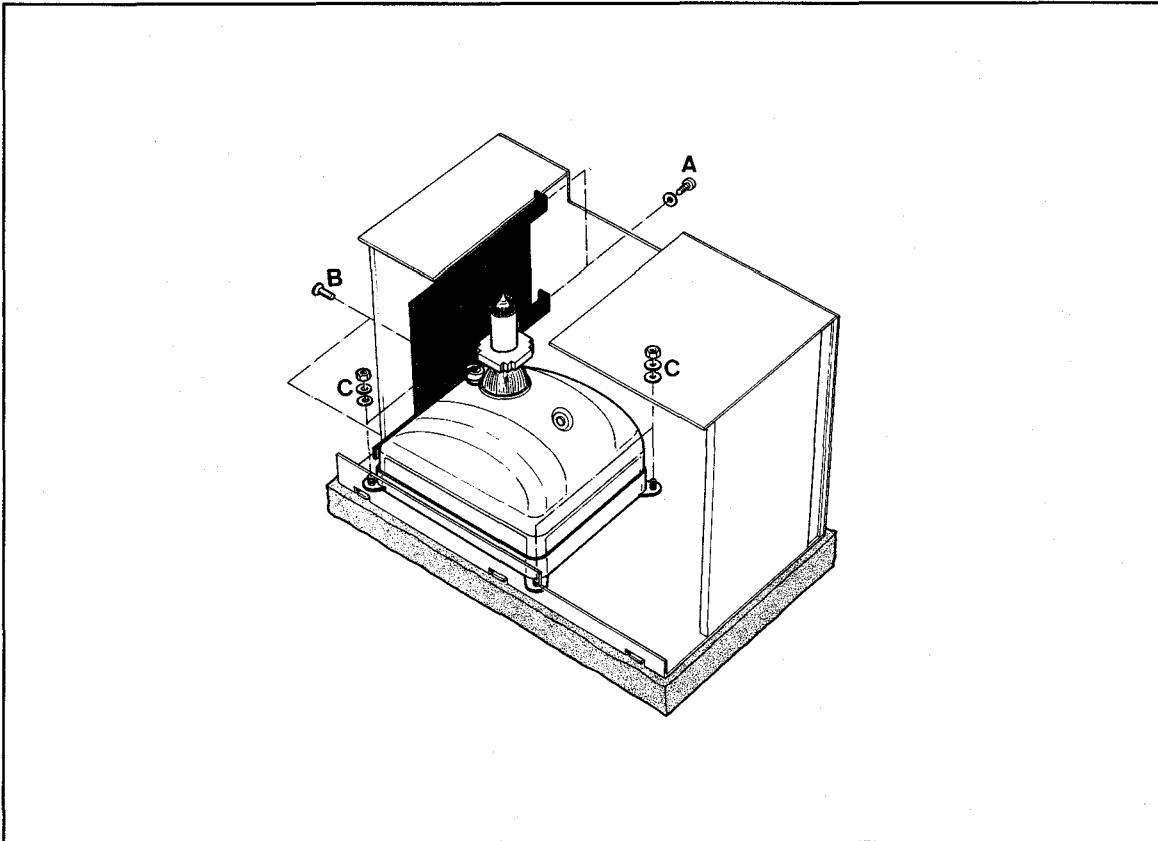

Figure 4-14. *Mounting of CRT*

7. Remove and save the two screws (A) securing the CRT shield to the bottom of the monitor, and the two screws (B) securing the CRT shield to the left side panel of the monitor.
8. Remove the CRT shield from the monitor.
9. Remove and save the nuts and washers (C) securing the corners of the CRT mounting bracket to the chassis mounting screws.
10. Carefully lift the CRT out of the monitor, observing standard safety procedures in the handling of the CRT.

4.19.2. Installing the CRT

1. Position the monitor face down on a clean, soft, flat surface.
2. Set the CRT into the monitor so that the mounting screws on the chassis protrude through the mounting holes on the corners of the CRT mounting bracket.
3. Secure the CRT mounting bracket to the chassis using four nuts and eight washers.

NOTE: Place two washers between the nut and mounting tab on each mounting screw.
4. Reinstall the CRT shield, and secure the shield in position with two Phillips-head screws and washers (A) through the bottom of the chassis, and two Phillips-head screws and washers (B) through the left side panel.
5. Reinstall any previously installed Option Board following proce-

System SIRECUST 1280/1281 Bedside Monitor - Service Manual

dures of Section 4.9.5. (Omit Steps 3 and 6 in Section 4.9.5.)

6. Reinstall the Curve Board following procedures outlined in Section 4.4.3. (Omit Step 6).
7. Complete the procedure of Section 4.11.2 to reinstall the Z-Amp Board reassemble the monitor. (Omit Step 6 in Section 4.10.2.)

4.20. Main Power Input Line Filter

Refer to Figure 4-15.

4.20.1. Removing the Main Power Input Line Filter

1. Remove the outer case of the monitor following the procedure outlined in Section 4.1.1.
2. Remove the Power Supply Board following the procedure outlined in Section 4.2.1.

3. Remove and save the two Phillips-head screws and washers (A) securing the line filter housing to the monitor chassis.
4. Remove and save the chassis grounding post (B), lock-washer, and nut on the filter housing.
5. Lift the Power Supply Line Filter assembly out of the monitor.

4.20.2. Installing the Main Power Input Line Filter

1. Position the Main Power Line Filter unit so that the mounting holes in the line filter housing align with the mounting holes in the chassis, and the filter grounding tab aligns with the chassis post hole.
2. Insert Phillips-head screws with washers (A) into the mounting holes, and tighten the screws to secure the housing to the chassis.

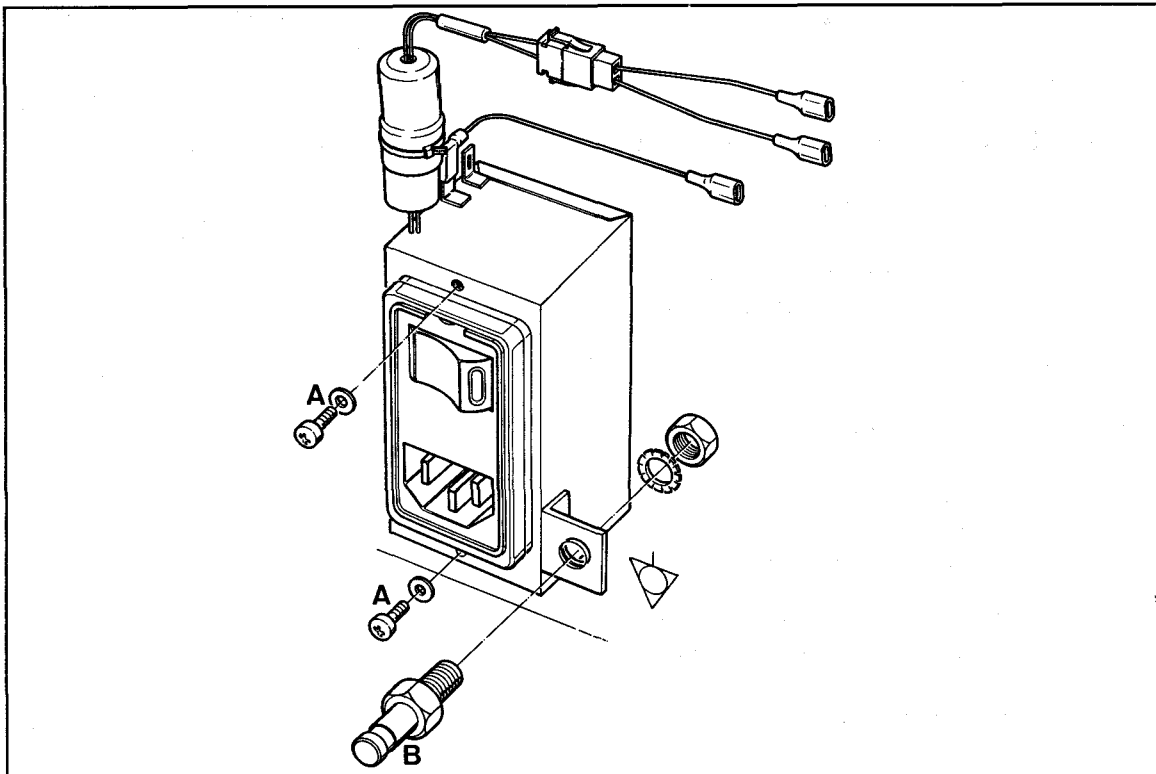

Figure 4-15. Main Power Input Line Filter

3. Insert the grounding post (B) into the mounting hole and secure the post to the chassis with a lock-washer and nut.
4. Complete procedure outlined in Section 4.2.2. to reinstall the Power Supply and reassemble the monitor.

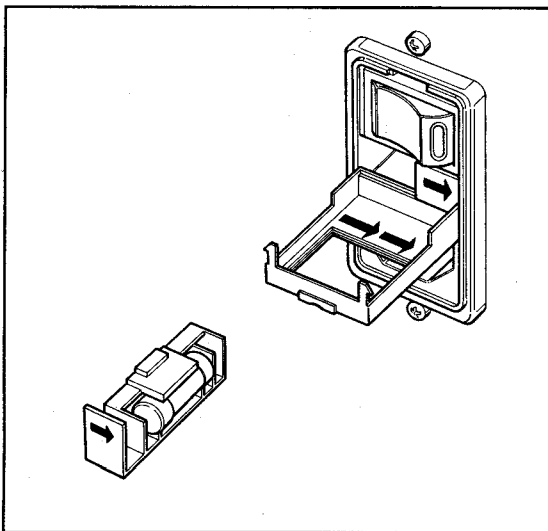

Figure 4-16. Main Power Input Fuses

4.21. Replacing Fuses

4.21.1. Main Power Line Input Fuses

Refer to Figure 4-16.

1. Switch main monitor power OFF, and disconnect power line cord.
2. Open cover cap.
3. Remove both fuse holders.
4. Install new fuses.
5. Close and seat the cover cap.
6. Reinstall main power line cord, and switch monitor power ON.
7. Verify that all monitor functions are performing properly. Refer to Chapter 5.

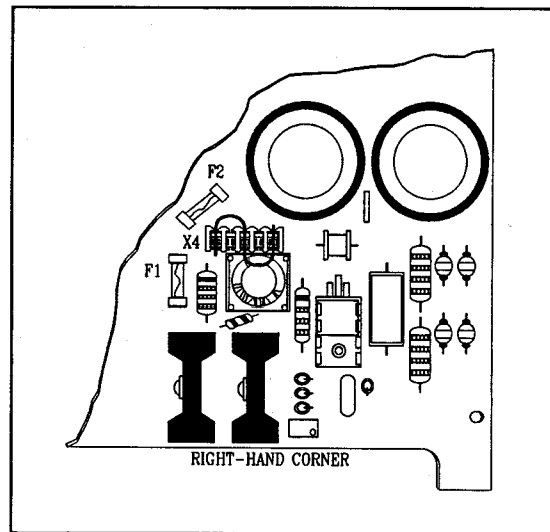

Figure 4-17. F1 and F2 on Power Supply Board

4.21.2. F1, F2 - Power Supply Board

Refer to Figure 4-17.

1. Remove Power Supply Board following procedures outlined in Section 4.2.1.
2. Replace fuses F1 and F2, located adjacent to X4.
3. Reinstall the power supply following procedures outlined in Section 4.2.2.

CHAPTER 5

FUNCTIONAL VERIFICATION

TABLE OF CONTENTS

5.	FUNCTIONAL VERIFICATION	1
5.1.	Introduction	1
5.2.	Tools and Test Equipment	1
5.3.	Operational Verification	2
5.3.1.	Speaker Test	2
5.3.2.	Power LED Test	2
5.3.3.	Power Consumption Test	2
5.3.4.	TouchScreen Test	2
5.3.5.	Display Verification	3
5.3.5.1.	Screen Alignment Test	3
5.3.5.2.	Color Display Test - SIRECUST 1281 Monitors	4
5.3.6.	Ambient Light Sensor	4
5.3.7.	Digital I/O Tests	4
5.4.	SIREM/Cartridge Tests	6
5.4.1.	Monitor Shutdown Test	6
5.4.2.	SIREM Input Verification	6
5.5.	Overall Monitor Function Test	7
5.5.1.	Memory Backup Test	8
5.5.2.	Lead-Off Test	8
5.5.3.	Cable Unplugged Test	8
5.5.4.	Temperature Test	9
5.5.5.	Cardiac Output Test	9
5.5.6.	Alarms Test	9
5.5.6.1.	Advisory Alarm Verification (software version VC)	9
5.5.6.2.	Advisory Alarm Verification (software version VE)	9
5.5.6.3.	Serious Alarm Verification	9
5.5.6.4.	Life Threatening Alarm Verification	10
5.6.	Communication Tests	10
5.6.1.	Screen Recording	10
5.6.2.	Continuous Recording	10
5.7.	Leakage Current Test	11

LIST OF TABLES

Table 5-1.	Recommended Tools and Test Equipment for Functional Verification ..	1
Table 5-2.	Leakage Current Tests	11

5. FUNCTIONAL VERIFICATION

5.1. Introduction

Functional verification should be performed annually during scheduled service intervals, whenever proper operation of the monitor is suspect, and after the monitor has been closed following recalibration or repair. These procedures validate proper operation of the monitor hardware. Many of the monitor's functions, such as alarms and waveforms and scale sizing, are software operations. The monitor's software is automatically checked during the monitor power-up and on-line self-tests. All software functions are performing in accordance with design specifications if no error messages are displayed. Some error messages relate to hardware failures.

This chapter describes the test methods used to verify the functional operation of SIEMENS SIRECUST 1280 and 1281

bedside monitors. When performing the following tests, always use the specified recommended equipment or a known equivalent. Use of unauthorized test equipment could result in inconclusive tests or damage to the monitor.

If the monitor should need calibration or fail to perform according to specifications, the procedures in this chapter refer service personnel to other chapters in this Manual, for recommended service.

5.2. Tools and Test Equipment

The tools and test equipment recommended for the functional verification procedures are listed in Table 5-1. Substitutions are approved only if an equivalent is listed.

All test equipment specified in these procedures is assumed to be operating in accordance with the manufacturers specifications.

Table 5-1. Recommended Tools and Test Equipment for Functional Verification

<u>UNIT</u>	<u>DESCRIPTION</u>
SIREM Remote Cartridge Unit	SIEMENS Art. No. 85 39 926 E2506
SIRECUST LIM Cartridge	
60 Hz.	SIEMENS Art. No. 89 92 020 E2507
50 Hz.	SIEMENS Art. No. 88 62 252 E2507
50 Hz. PTB	SIEMENS Art. No. 88 61 700 E2507
SIREM Cable	SIEMENS Art. No. 89 44 787 E2513 or Art. No. 87 93 440 E2513
5-Lead EKG Patient Cable	SIEMENS Art. No. 45 27 529 EH405
5-Lead Set	SIEMENS Art. No. 45 28 030 EH405
SDL 4 Cable	SIEMENS Art. No. 87 94 810 E2513
12" Video Alignment Grid	SIEMENS Art. No. 84 28 450 RE999.
SDL Breakout Box	SIEMENS Art. No. 12 66 811 EE50U
Temperature Simulator Test Plug	See Appendix E. Buildable Test Equipment
Cardiac Output Test Plug	See Appendix E. Buildable Test Equipment
Digital Multi Meter (DMM), 4½ digit	Fluke, Model 8050A (or equivalent)
Leakage Current Analyzer	Dynatech-Nevada, Model 432D (or equivalent)
Watt Meter (Optional)	Valhalla Scientific, Model 2101 (or equivalent)
Polymed Simulator	SIEMENS Art. No. 45 28 345 EH436
or	
Waveform Simulator	Dynatech-Nevada, Model 215A (or equivalent)
Ruler, Precision Millimeter Grade	

5.3. Operational Verification

If the operation of the bedside monitor is suspect, or repair and calibration work has been performed, use the following procedures to verify monitor operation.

5.3.1. Speaker Test

1. Turn monitor power ON.
2. The speaker should emit a tone prior to the beginning of the self-test. Verify presence of speaker tone.
 - Yes: Continue with test.
 - No: Refer to Chapter 6, Section 6.7J.

5.3.2. Power LED Test

1. Check that the green power indicator on the lower right side of the Front Panel is lit.
2. Power indicator is On,
 - Yes: Continue with test.
 - No: Refer to Chapter 6, Section 6.7A.

5.3.3. Power Consumption Test (Optional test)

1. Turn monitor power OFF.
2. Disconnect SIREM from monitor.
3. Disconnect any SDL 6 or SDL 8 cable(s) attached to an Option Board at X5, X6, X7, and or X8.
4. Remove any Option Boards installed in the 1280/1281 before commencing with the Power Consumption Test.

NOTE: Functional verification tests are normally "covers-on" tests. However, some

monitors are equipped with an option board that may affect test results. Remove the board before performing the power consumption test. Refer to Chapter 4, Section 4.9, for removal and reinstallation instructions.

WARNING: Assure that the top cover is installed before performing the power consumption test.

5.
 - a. Connect the wattmeter to a 110/220 vac power source.
 - b. Connect the monitor to the wattmeter.
 - c. Switch monitor power ON.
 - d. Verify that monitor power ≤ 155 watts (1280) or ≤ 175 watts (1281).
 - Yes: Monitor power is within specifications. Continue.
 - No: Refer to Chapter 7, Section 7.1.
6. Switch monitor power OFF.
7. Reinstall any Option Board (refer to Chapter 4, Section 4.9) and cables previously removed.
8. Continue with functional verification procedures.

5.3.4. TouchScreen Test

Turn the monitor power ON. After the start up self-tests sequence is complete, press the left-side of the display screen.

1. Calibrate the TouchScreen following the procedure given by the screen message prompts.
2. Assure TouchScreen accuracy by selecting the following keys in sequence:

- a. Press the CO parameter box key.
 - b. Press the HEMO CALC key.
 - c. Press input arrow key up or down to display keypad calculator.
 - d. Press the numerics of the calculator keypad, anywhere within the numeric key outline, and verify that the correct value is displayed on the calculator.
2. Position the video alignment grid on the display screen.
 3. Verify that the raster pattern lines are within 1.0 mm of the video alignment grid pattern.
 4. Assure that the curve to raster alignment is within 1.0 mm.
 5. Check curve-grid alignment using two pressure inputs provided by a known good LIM and a patient simulator.

Does the TouchScreen operate properly as described?

- Yes: Continue with functional verification procedure.
- No: Refer to Chapter 6, Section 6.71.

5.3.5. Display Verification

NOTE: The following procedures verify functioning of the screen display circuitry.

5.3.5.1. Screen Alignment Test

NOTE: Switch monitor power ON and allow the monitor power to remain ON for at least one hour prior to attempting to verify proper screen alignment.

NOTE: If the monitor display is not within specified tolerances in any Step of this Section, go to Chapter 7, Section 7.3, and follow the procedures outlined before continuing with functional verification testing.

1. Press the following keys in sequence to enter the DISPLAY ALIGNMENT mode.

DISPLAY/SETUP
MORE SETUP (sw version VF)
DIAGNOSTICS
DISPLAY ALIGNMENT
B

- a. Exit display alignment test pattern mode by either of the following means:

Press the B fixed key repeatedly until the DIAGNOSTIC menu appears.

Press MAIN SCREEN fixed key to return to main screen.

or

Turn monitor power OFF.

NOTE: Turning power OFF causes loss of patient data.

- b. Place the LIM in the top two slots of the SIREM.
- c. Connect a patient simulator to the two pressure inputs of the LIM, and set the pressure gain controls of the simulator to 0 mm/Hg.
- d. Attach the SIREM to the SIREM 1 input (X16) on the rear panel of the monitor.

NOTE: Turn monitor power OFF whenever connecting or disconnecting a SIREM.

- e. Switch monitor power ON.

- f. Set the monitor to exhibit two non-overlapping pressure flatlines. Refer to the Operating Instructions for the installed software version.
- g. Zero each pressure flatline using the pressure ZERO parameter keys.
- h. Assure that each pressure curve is aligned to its zero grid within $\pm 0.5\text{mm}$.

Is the screen alignment within specifications?

- Yes: Continue with functional verification testing.
- No: Proceed to Display Alignment procedure, Chapter 7, Section 7.3.

5.3.5.2. Color Display Test - SIRECUST 1281 Monitors

1. Display a test pattern by pressing the following keys:

DISPLAY/SETUP
MORE SETUP (sw version VF)
DIAGNOSTICS
DISPLAY ALIGNMENT
B

2. Verify the presence of the colors green, yellow, orange and red.

NOTE: The entire length of each waveform should have unvarying hue and degree of intensity.

3. Are the colors true for each waveform?
 - Yes: Select MAIN SCREEN fixed key and continue.
 - No: Refer to Chapter 6, Section 6.7.R.i.

5.3.6. Ambient Light Sensor

Test the ambient light sensor as follows:

1. Press the Display/SETUP fixed key.
2. Press the DIAGNOSTIC program key, followed by the FIELD SERVICE key.

NOTE: This is a password protected function. For the applicable password. Refer to the Beside Setup Instructions or Password Disclosure Document for the installed software version.

3. Press the DISPLAY TOUCH VALUES key.
4. Cover the ambient light sensor in the upper right corner of the TouchScreen for ten seconds.

Verify that the left-most value at the top of the display screen is between LD800 and LFF00.

Are the Ambient Light Sensor values within specification?

- Yes: Continue with functional verification testing.
- No: Refer to Chapter 6, Section 6.7Q.2.

5. Press the DISPLAY TOUCH VALUES key once again to disable the Touch Values.

5.3.7. Digital I/O Tests

The following tests verify proper operation of the digital I/O lines. If the monitor fails to respond as indicated in any of the following tests, see Chapter 6, Section 6.7S, and follow the procedures outlined before continuing with functional verification.

NOTE: The following test procedures require access to the back panel.

CAUTION: Turn monitor power OFF whenever connecting or disconnecting cables and test equipment.

1. PACE I/O Verification:

- a. Attach the SIEMENS SDL4 cable to ALARM connector X10, on the Monitor.
- b. Attach the free end of the SDL4 cable to X4 (SLD4) of the breakout box.
- c. Connect a jumper from X4/1 to X4/3 on the breakout box.
- d. Connect the - lead of the DMM to shield-pin and the + lead to X4/3.
- e. Press DIAGNOSTIC key to access the DIGITAL I/O TEST menu.
- f. Press the PACE program key. Verify that the PACE output measured on X4/3 decreases from 5 VDC to <0.1 VDC.
- g. Press the PACE key. Verify that the PACE output returns to 5 ± 0.5 VDC.
- h. Remove the jumper from X4.

2. ALARM I/O Verification:

- a. Connect the positive lead of the DMM to X4/2.
- b. Press the ALARM program key. Verify that the ALARM output decreases from 15 VDC to <1.5 VDC.
- c. Press the ALARM key again. Verify that the ALARM output returns to 15 ± 0.5 VDC.

3. SYNC I/O Verification:

- a. Connect the + lead of the DMM to X4/4.
- b. Press the SYNC program key. Verify that the SYNC output voltage decreases from 15 VDC to <1 VDC.
- c. Press the SYNC key again. Verify that the SYNC output voltage returns to 15 ± 0.5 VDC.

4. I/O State Condition Test:

- Connect a jumper from X4/1 to X4/3 on the breakout box.
 - Change the PACE state from a 1 level ($\approx +5$ VDC) to a 0 level, using the PACE key.
- a. Press the INPUTS key within the menu.
 - b. Verify that the SYNC IN value changes from a 1 level to a 0 level.
 - c. Change the PACE state to 1.
 - d. Press the INPUTS Key again. Verify that the SYNC IN value returns to the 1 condition.
- Remove the jumper from X4/1-3.
 - Move the SDL4 Cable to the SIRENET connector, X9.
 - Connect a jumper between X4/3 and X4/4.
 - Connect the + lead of the DMM to X4/3.
 - Verify that the Bed value is 1.
- a. Change the SYNC state from a 1 level to a 0 level using the SYNC key.

- b. Press the INPUTS key. Verify that the BED value changes from a 1 level to a 0 level.
 - c. Press the SYNC key again.
 - d. Press the INPUTS key. Verify that the BED state changes from a 0 level to a 1 level.
3. Insert Temperature Simulator Test Plugs into the TEMP input jacks of the LIM cartridge.
 4. Set the monitor to display the active patient input parameters provided by the simulator. Refer to the Operating Instructions for the installed software version, Order No. A91004-M3331-L079-XX-7600.

5.4. SIREM/Cartridge Tests

CAUTION: Switch the monitor power OFF before connecting or disconnecting the SIREM cable to prevent equipment damage.

5.4.1. Monitor Shutdown Test

1. Connect a SIREM equipped with a LIM and any two of the following cartridges (if available) to the SIREM 1 input, X16, on the back of the monitor.
 - PCO2 Cartridge with transducer,
 - SaO2 Cartridge,
 - NIBP Cartridge.
2. Rapidly eject all cartridges from the SIREM and reinsert them.
3. Does the monitor shutdown?
 - Yes: Go to Chapter 6, Section 6.7F.
 - No: Switch the monitor OFF and continue with test.

5.4.2. SIREM Input Verification

1. Connect a patient simulator to the EKG and PRESSURE inputs of the LIM cartridge.
2. Set the simulator controls to provide an EKG waveform of 80 BPM @ 1mV, and two blood pressure curves.

5. Is the display in accordance with the configuration of the SIREM and as indicated in the Operating Instructions.

- Yes: Continue with test.
- No: Refer to Chapter 6, Section 6.7K.

6. Examine each waveform for the presence of noise spikes, glitches, or voids.

Is the display free of noise and voids?

- Yes: Continue with test.
- No: Go to Chapter 6, Section 6.7R.

7. Switch monitor power OFF. Disconnect the SIREM cable from X16, and connect it to X17.

8. Switch monitor power ON.

9. The active parameters are displayed on the monitor screen.

Is the display in accordance with the configuration of the SIREM and as indicated in the Operating Instructions?

- Yes: Continue with test
- No: Refer to Chapter 6, Section 6.7K.

10. Examine each waveform for the presence of noise spikes, glitches, or voids.

Is the display clear of noise or voids?

- Yes: Continue with test
- No: Refer to Chapter 6, Section 6.7R.

5.5. Overall Monitor Function Test

Verify that the bedside controls and displays are all functional prior to placing the monitor in operational service:

NOTE: If the monitor fails to respond properly in any of the Steps below, refer to the appropriate section of Chapter 6 to troubleshoot and repair the unit before returning to this Section.

1. QRS/EKG Channel:

- a. The heart symbol is present with each QRS complex.
 - Yes: Continue with test.
 - No: Check input from LIM.
- b. UP and DOWN keys in QRS VOLUME menu vary volume.
 - Yes: Continue with test.
 - No: Refer to Chapter 6, Section 6.7J.

2. Curve Sweep Test:

Press the SWEEP SPEED UP (arrow) key and set the speed for 50 mm/sec.

Verify that all waveforms are free of spikes or voids.

- Yes: Continue with test.

- No: Refer to Chapter 6, Section 6.7R.

3. Intensity Control Test:

Verify independent control of raster and curve display intensities using the INTENSITY keys.

- Yes: Continue with test.
- No: Refer to Chapter 6, Section 6.7R.v.

4A. Pacer Detection Test: Using the Dynatech-Nevada (D-N) Patient Simulator

- a. Verify that PACEMAKER DETECT is set to ON on the monitor. Refer to Operating Instructions.
- b. Select the "async 75 bpm" option (located under the Paced Rhythms sub-menu).
- c. Verify that the Pacer Indicator symbol flashes on the 128x display.
- d. Select the "non-function" option of the Paced Rhythms sub-menu.
- e. The message: **ASY**, should appear in the HR Parameter Box.
- f. Watch the display for 30-40 seconds. Assure that the **ASY** message is not replaced by a heart rate for more than five seconds.

4B. Pacer Detection Test: Using the SIEMENS Polymed Simulator:

- a. Verify that PACEMAKER DETECT is set to ON on the monitor. Refer to Operating Instructions.

- b. Hold the PACE button down.

Verify that the Pacer Indicator symbol flashes.

- c. Adjust the EKG+RESP control for a flatline of the EKG waveform.

- d. Hold the PACE button down.

Verify that a Pacer spike train is visible on the EKG waveform.

The **ASY** message appears in the HR Parameter Box.

Watch the display for 30-40 seconds to assure that the **ASY** message is not replaced by a heart rate number for a duration of more than five seconds.

Does the monitor respond as described?

- Yes: Continue with test.
- No: Replace LIM cartridge, and retest.

5.5.1. Memory Backup Test

1. Press the MAIN SCREEN key.
2. Observe the Heart Rate alarm limit that is presently displayed.
3. Change the Upper Limit by increasing or decreasing the present limit by 15 BPM. Note the new limit.
4. Switch the monitor power OFF for 10 minutes.
5. Switch the power ON, and verify that the new Heart Rate alarm limit value was retained.

Did monitor retain new limit after the 10 minute power down?

- Yes: Continue with test.
- No: Refer to Chapter 6, Section 6.7H.

5.5.2. Lead-Off Test

Perform a Lead-Off test as follows:

1. Select the appropriate cable size (3-lead, 4-lead, or 5-lead) in the EKG menu. Refer to Operating Instructions.
2. Disconnect the EKG electrode clips from the simulator.
3. Attach all leads to a metal screw-driver shaft to create a short-circuit condition.
4. Disconnect each electrode clip individually to verify that a LEAD OFF message indicating the open lead is displayed, which clears once the lead is reconnected.

Did the Lead-Off test perform as described?

- Yes: Continue with test.
- No: Replace faulty wire(s) from the set.

or

Replace the LIM cartridge.

5.5.3. Cable Unplugged Test

Verify that the PRESSURE alarms are ON.

1. Unplug the Pressure 1 simulator input cable from the LIM. Verify that the ***U*** replaces the pressure 1 value while the pressure curve disappears from the display.
2. Repeat the test for Pressure channel 2.

Does the monitor respond as described?

- Yes: Continue with test.
- No: Replace LIM and retest.

Serious

Steady high frequency tone

Life Threatening Alternating high and low frequency tones

5.5.4. Temperature Test

1. Insert a -5°C Temperature Simulator Test Plug, into T1 of the LIM Cartridge. Verify that the value in the Temperature Parameter Box is $-5 \pm 0.2^\circ\text{C}$.
2. Insert the 37°C test plug and verify the value is $37 \pm 0.1^\circ\text{C}$.

Are Temperatures values correct?

- Yes: Continue with test.
- No: Replace LIM and retest.

5.5.5. Cardiac Output Test

1. Insert the Cardiac Output Test Plug, into the CO input jack.
2. Press the CO Parameter Box.
3. Press the START Key.

Verify that the displayed Blood Temp Value is $37 \pm 0.15^\circ\text{C}$, and the Injectate Temp Value is $1 \pm 0.25^\circ\text{C}$.

Did the monitor display exhibit the specified values?

- Yes: Continue with test.
- No: Replace LIM and retest.

5.5.6. Alarms Test

Assure the monitor responds to the following alarm simulations.

Advisory Steady low frequency tone

5.5.6.1. Advisory Alarm Verification (software version VC)

1. Enable the RR alarm. Refer to Operating Instructions.
2. Use the UPPER LIMIT Alarm arrow keys to reduce the upper alarm limit below the simulated rate shown in the RR parameter box.

Verify that the monitor responds with an **advisory** alarm.

3. Reset the upper limit to a value above the simulated rate.

Verify that the alarm clears.

4. Disable the Alarm and return the RR Upper Limit to its original setting.

5.5.6.2. Advisory Alarm Verification (software versions VE and VF)

1. Verify that HR Alarms are ON.
2. Unplug the EKG input cable from the LIM.

Verify that the monitor responds with an **advisory** alarm.

3. Plug the EKG input cable back into the LIM.

Verify that the alarm clears.

5.5.6.3. Serious Alarm Verification

1. Verify that the HR Alarms are ON.
2. Set patient simulator to provide normal EKG input at 80 bpm.

3. Set upper HR alarm limit to 75 bpm.

Verify that the unit responds with a **serious** alarm.

4. Reset the upper limit to a value above the simulated rate.

Verify that the alarm clears.

5.5.6.4. Life Threatening Alarm Verification

1. Set the simulator to ASYSTOLE.

Verify that a **life threatening alarm** tone is sounded. The display exhibits an ASYSTOLE message.

2. Reset the simulator for a normal heart rate.

3. Press the Alarm Silence fixed key to clear the latched alarm.

Does each alarm status respond as described above?

- Yes: Continue with test.
- No: Refer to Chapter 6, Section 6.7.J.1.

5.6. Communication Tests

NOTE: The bedside monitor and S220 recorder must contain software version VE0 or higher.

1. Connect a known good SIREDOC S220 recorder to X9 on the rear panel of the monitor.
2. Place the monitor in Standalone mode. Refer to the Bedside Setup Instructions in the Operating Instructions for the installed software version.

5.6.1. Screen Recording

1. With the patient simulator connected to the LIM, set the simulator to provide signal curves to the bedside.

2. With display curves on the monitor, press the STOP CURSOR fixed key. The monitor display becomes motionless.

3. Press the Print Screen fixed key.

The message: PRINT SCREEN STARTED appears at the top of the screen.

4. The message: PRINT SCREEN DONE appears after the command has been processed.

5. Compare the recorded screen printout to the display of the bedside monitor.

Is the printout identical to the monitor display?

- Yes: Select STOP CURSOR to reset the display screen, and continue with test.
- No: Refer to Chapter 6, Section 6.7M.

5.6.2. Continuous Recording

1. Press the RECORD SELECT fixed key.

2. Select the 8 CHANNEL 25 mm/sec CONT key.

The message CONT RECORDING STARTED is displayed at the top of the screen.

3. Verify that a recording is initiated.

System SIRECUST 1280/1281 Bedside Monitor - Service Manual

4. Press the 8 CHANNEL 25 mm/sec CONT key again to stop the recording.
5. The message CONT RECORDING CANCELED appears.

5.7. Leakage Current Test

1. Attach the monitor to the leakage current analyzer using the manufacturer's instructions.
2. Perform each of the tests listed in Table 1 for each of the following conditions:
 - open ground
 - reversed polarity
 - open ground reversed polarity.

The current must not exceed the values shown in Table 5-2.

Table 5-2. Leakage Current Tests

<u>TEST</u>	<u>MAX CURRENT</u>
Chassis to Ground	< 100 μ A
Combined Lead Leakage	< 10 μ A *
Individual Lead Leakage	< 10 μ A *
Paired Lead Leakage	< 10 μ A *
Leakage with Line Voltage on Leads	< 10 μ A *

* Add an additional 10 μ A if the measurements are taken at the patient end of patient lead cables.

CHAPTER 6

TROUBLESHOOTING

TABLE OF CONTENTS

6.	TROUBLESHOOTING	1
6.1.	Introduction	1
6.2.	Reference Documents	1
6.3.	Signal Representation	2
6.4.	Replacement of Boards During Troubleshooting	2
6.4.1.	Display Subsection Boards	5
6.4.2.	Signal Processing and Control Boards	5
6.5.	Signal Summary	5
6.6.	Troubleshooting Flowchart	5
6.7.	Troubleshooting Procedures	6
6.7A.	No Display	6
6.7B.	Monitor Powers Up Properly Sometimes and Sometimes Does Not ..	12
6.7C.	Monitor Omits Start-Up Self Tests	12
6.7D.	Error Messages	13
6.7E.	Monitor Produces a Constant Error Tone	13
6.7F.	Monitor Powers Down During Start-Up Self Tests or During Normal Operation	14
6.7G.	Display Resets	14
6.7H.	Data Not Maintained During Power Interruptions	15
6.7I.	TouchScreen Drifting or Not Functioning Properly	16
6.7J.	Problem With Speaker Tones	18
6.7K.	Cartridge(s) Not Recognized or Cartridge Slots Non-functional	19
6.7L.	SIRENET Communication Problem	21
6.7M.	Standalone Recorder Communication Problem	21
6.7N.	Problem With Option Board Outputs	21
6.7O.	Time Not Being Updated By Central Station	22
6.7P.	Standalone Time Not Maintained Following Power Interruptions ..	22
6.7Q.	Automatic Ambient Brightness Adjustment Not Functioning Properly .	23
6.7R.	Display Abnormality	23
6.7R.i.	Color Shutter Malfunctioning	23
6.7R.ii.	Fold Over	24
6.7R.iii.	Entire Display Appears In One Section of Screen.	24
6.7R.iv.	Out of Focus, Unable to Adjust	24

TABLE OF CONTENTS (Continued)

6.7R.v.	Intensity Too Bright or Too Dim, Unable to Adjust	25
6.7R.vi.	Only Dot or Flat Line Appears	25
6.7R.vii.	Oversized Display	26
6.7R.viii.	Poor Alignment	26
6.7R.ix.	Blanking Problem	26
6.7R.x.	Glitches in Display	26
6.7R.xi.	Curves Jittering	26
6.7R.xii.	Display Size Fluctuating	26
6.7R.xiii.	Blinking	27
6.7S.	Digital I/O Problem	27
6.8	Curve Board Test	27

LIST OF FIGURES

Figure 6-1.	Troubleshooting Flow Chart	7
Figure 6-2.	TouchScreen Connector	27
Figure 6-3.	Z (After DISPLAY SET-UP Fixed Key is Pressed): 1280 (Curve Board: X8-1) (2V/div., 5ms/div.)	28
Figure 6-4.	Z (After DISPLAY SET-UP Fixed Key is Pressed): 1281 (Curve Board: X8-1) (2V/div., 5ms/div.)	28
Figure 6-5.	TouchScreen Accuracy Test Limits	29
Figure 6-6.	BEEPER (Mother Board, X6-2) (1V/div., 1ms/div.)	29
Figure 6-7.	CLK Signals for SIREM (Rear Panel Connectors X16/X17: Pins 1→2, 3→4, 5→6, 7→8) (2V/div., 0.1 ms/div.)	30
Figure 6-8.	25K (Rear Panel Connectors X16/X17: Pin 17→18) (2V/div., 10 μ s/div.)	30
Figure 6-9.	SH1, SH2, SH3, SH4 (Operator Interface Board: X2-7, X2-8, X2-9, X2-10) (5V/div., 5ms/div.)	31
Figure 6-10.	LEFTR/G, RIGHTR/G (VME Extender Bd., Curve Bd. Connected: TP2 C-21, C-22) (5V/div., 5ms/div.)	31
Figure 6-11.	SHCLK (VME Extender Bd. With Curve Bd. Connected: TP2 C-23) (5V/div., 5ms/div.)	32
Figure 6-12.	VIDEO IN: 1280 (Z-Amp Board: R30 Upper Leg) (2V/div., 2ms/div.)	32
Figure 6-13.	BLANKING: 1280 (Z-Amp Board: R5 Upper Leg) (2V/div., 5ms/div.)	33
Figure 6-14.	VIDEO IN: 1281 (Z-Amp Board: R30 Upper Leg) (2V/div., 2ms/div.)	33
Figure 6-15.	BLANKING: 1281 (Z-Amp Board: R5 Upper Leg) (2V/div., 2ms/div.)	34
Figure 6-16.	CATHODE: 1280 (Z-Amp Board: R28 Right Leg) (10V/div., 2ms/div.)	34
Figure 6-17.	CONTROL: 1280 (Z-Amp Board: F1 Left Leg) (50V/div., 5ms/div.)	35

LIST OF FIGURES (Continued)

Figure 6-18.	CATHODE: 1281 (Z-Amp Board: R28 Right Leg) (20V/div., 2ms/div.)	35
Figure 6-19.	CONTROL: 1281 (Z-Amp Board: F1 Left Leg) (50V/div., 2ms/div.)	36
Figure 6-20.	Curve Board Signals for 1280	36
Figure 6-21.	Curve Board Signals for 1281	36
Figure 6-22.	Pin Locations on Curve Board Output Connectors	37
Figure 6-23.	Curve Board Output Signal Limits	37

LIST OF TABLES

Table 6-1.	Recommended Tools and Test Equipment for Troubleshooting	1
Table 6-2.	Monitor Malfunction Symptoms	2
Table 6-3.	Signal Summary	3
Table 6-3.	Signal Summary (Continued)	4
Table 6-3.	Signal Summary (Continued)	5
Table 6-4.	Power Supply Board Test Points	9
Table 6-5.	TouchScreen Test Values	17
Table 6-6.	Clock Signals for SIREM	19
Table 6-7.	Differential Signals from SIREM	20
Table 6-8.	Color Shutter Drive Signals	23

6. TROUBLESHOOTING

6.1. Introduction

The troubleshooting philosophy for System SIRECUST 1280/1281 bedside monitors is for troubleshooting and repair to be performed to only the PC board level. Component level troubleshooting procedures are not provided in this Manual.

Detailed schematic diagrams are provided in Appendix B to assist technicians in understanding the theory of operation of monitor circuitry. Attempting to repair 1280/1281 PC boards to the component level may void any warranty, express or implied, for that PC board.

Troubleshooting a 1280/1281 monitor is a two-stage operation. First, associate any problem, discovered through either an informal or formal functional verification of

monitor operations, with one of the symptoms listed in Table 6-2.

Second, verify that the necessary voltages and or signal levels exist at the pre-determined test points, as specified in Table 6-3. If these voltages or signal levels are not present, then the PC board or subassembly under test is defective and must be replaced.

6.2. Reference Documents

The following publications are referred to in this Chapter, and are recommended for additional information relevant to troubleshooting and repairing bedside monitors.

- SIREM Service Manual, Order No. E331.E2506.061.01.01.09.
- SIRECUST 202D Service Manual, Order No. E321.E2534.061.01.02.02, or E321.E2534.061.05.01.02.

Table 6-1. Recommended Tools and Test Equipment for Troubleshooting

<u>TOOL OR EQUIPMENT</u>	<u>DESCRIPTION</u>
Current Shunt, mono (1280)	SIEMENS Art. No. 96 60 606 EE999
Current Shunt, color (1281)	SIEMENS Art. No. 96 60 614 EE999
12 inch display video alignment grid	SIEMENS Art. No. 84 28 450 RE999
VME Extender Board	SIEMENS Art. No. 87 91 568 E2524
Power Supply PC Board, Extender Harness	SIEMENS Art. No. 45 32 537 EE50U
Curve PC Board, Extender Harness	SIEMENS Art. No. 45 32 529 EE50U
Deflection bd. extender harness, mono(1280)	SIEMENS Art. No. 45 32 511 EE50U
Deflection bd. extender harness, color (1281)	SIEMENS Art. No. 45 32 503 EE50U
Operator interface extender harness	SIEMENS Art. No. 12 66 449 EE50U
SDL 4, 6, 8 breakout box	SIEMENS Art. No. 12 66 811 EE50U
POLYMED/LIM simulator:	SIEMENS Art. No. 45 28 345 EH436
Oscilloscope, 50MHz	Tektronix 2225 (or equivalent)
Logic probe	Global Specialties LP-3 (or equivalent)
Digital Multi Meter (DMM), 4½ digit	Fluke 8050A (or equivalent)
High voltage probe (for DMM), 1000:1 divider	Fluke 80K-40 (or equivalent)
Adjustment wand, w/ insulated handle and 1.8mm - 2.5mm blade	

- System SIRECUST Master Option Board Hardware Installation Instructions, Order No. A91004-M3331-T599-01-7600.
- SIRECUST 1280/1281 Wiring Diagrams, Order No. E331.E2501.051.90.01.09.

6.3. Signal Representation

Sections of this troubleshooting guide contain figures depicting waveforms present at test points referred to in the text. After each figure title, a voltage value

and a time value is listed. The values represent the scaling of the axis in the figure, volts/division and seconds/division, and are the recommended oscilloscope settings for observing the signals.

6.4. Replacement of Boards During Troubleshooting

Refer to Chapter 4 for instructions on removing and installing PC boards and subassemblies determined to be faulty by troubleshooting procedures.

Table 6-2. Monitor Malfunction Symptoms

<u>SYMPTOM(S)</u>	<u>SECTION</u>	<u>SYMPTOM(S)</u>	<u>SECTION</u>
No display.	A.	Problem with audible tones.	J.
Monitor powers up properly sometimes/sometimes does not.	B.	Cartridge(s) not recognized or cartridge slot(s) not functional.	K.
Monitor skips start-up self tests.	C.	SIRENET communication problem.	L.
Error messages.	D.	Standalone recorder communication problem.	M.
Monitor produces a constant error tone.	E.	Problem with option board outputs.	N.
Monitor powers down during start-up self tests or during normal operation.	F.	Time not updated by central station.	O.
Display resets.	G.	Standalone time not maintained following power interruptions.	P.
Data not maintained during power interruptions.	H.	Automatic ambient brightness adjustment not functioning properly.	Q.
TouchScreen drifting or not functioning properly.	I.	Display abnormality.	R.

System SIRECUST 1280/1281 Bedside Monitor - Service Manual

Table 6-3. Signal Summary

<u>SIGNAL</u>	<u>TEST POINT</u>	<u>BOARD OF ORIGIN</u>
+ 5V	X1 pin 6: Power Supply board	Power Supply
- 15V	X2 pin 1: Power Supply board	Power Supply
- 5V	X2 pin 2: Power Supply board	Power Supply
+ 24V	X3 pin 3: 1280 Power Supply board (A140 Power Supply rev < 3 only)	Power Supply
+ 25V	X3 pin 3: Power Supply board (A140 Power Supply rev \geq 3 only) (A280 Power Supply rev \geq 2M only)	Power Supply
+ 29V	X3 pin 3: 1281 Power Supply board (A280 Power Supply rev \leq 2L only)	Power Supply
+ 15V	X3 pin 4: Power Supply board	Power Supply
- 20V	X3 pin 7: Power Supply board	Power Supply
- 55V	X3 pin 8: 1280 Power Supply board (A140 Power Supply only)	Power Supply
- 80V	X3 pin 8: 1281 Power Supply board (A280 Power Supply only)	Power Supply
- 25V	X3 pin 9: 1281 Power Supply board (A280 Power Supply only)	Power Supply
BLANKING	X8 pin 5: Curve board	Curve
Z (same as VIDEO IN on HV/Z Amp board)	X8 pin 1: Curve board	Curve
VERTICAL	X7 pin 1: Curve board	Curve
HORIZONTAL	X7 pin 4: Curve board	Curve
LEFTR/G	TP2 pin C-21: VME Extender board (with Curve board connected)	Curve
RIGHTR/G	TP2 pin C-22: VME Extender board (with Curve board connected)	Curve
SHCLK	TP2 pin C-23: VME Extender board (with Curve board connected)	Curve

Table 6-3. *Signal Summary (Continued)*

<u>SIGNAL</u>	<u>TEST POINT</u>	<u>BOARD OF ORIGIN</u>
PACE OUT	X10 pin 3: Rear Panel	Curve
ALARM OUT	X10 pin 2: Rear Panel	Curve
SYNC OUT	X10 pin 4: Rear Panel	Curve
SH1	X2 pin 7: Operator Interface board	Operator Interface
SH2	X2 pin 8: Operator Interface board	Operator Interface
SH3	X2 pin 9: Operator Interface board	Operator Interface
SH4	X2 pin 10: Operator Interface board	Operator Interface
BEEPER	X6 pin 2: Mother board	Display Processor
BCHRG	TP2 pin C16: VME Extender board (with Display Processor board connected)	Display Processor
BATR+	JP1 pin 2: Battery board	Battery
PIEZO	JP90 pin 1: Mother board	Battery/Memory Back-Up
CATHODE	R28 right leg: Z-Amp board	Z-Amp
CONTROL	F1 left leg: Z-Amp board	Z-Amp
+15kV	CRT anode	Z-Amp
CLK A1	X16 pin 1 (ref. to pin 2): rear panel	Front End
CLK A2	X16 pin 3 (ref. to pin 4): rear panel	Front End
CLK B1	X16 pin 5 (ref. to pin 6): rear panel	Front End
CLK B2	X16 pin 7 (ref. to pin 8): rear panel	Front End
CLK C1	X17 pin 1 (ref. to pin 2): rear panel	Front End
CLK C2	X17 pin 3 (ref. to pin 4): rear panel	Front End
CLK D1	X17 pin 5 (ref. to pin 6): rear panel	Front End
CLK D2	X17 pin 7 (ref. to pin 8): rear panel	Front End

Table 6-3. Signal Summary (Continued)

<u>SIGNAL</u>	<u>TEST POINT</u>	<u>BOARD OF ORIGIN</u>
+15V EXTA	X16 pin 21 (ref. to pin 24): rear panel	Front End
+15V EXTB	X17 pin 21 (ref. to pin 24): rear panel	Front End
25K1	X16 pin 17 (ref. to pin 18): rear panel	Front End
25K2	X17 pin 17 (ref. to pin 18): rear panel	Front End
DCS A12	X3 pin 9 (ref. to pin 10): Front End board	SIREM
DCS B12	X3 pin 11 (ref. to pin 12): Front End board	SIREM
DCS C12	X4 pin 9 (ref. to pin 10): Front End board	SIREM
DCS D12	X4 pin 11 (ref. to pin 12): Front End board	SIREM

In addition, also consider the following information in Sections 6.4.1 and 6.4.2:

6.4.1. Display Subsection Boards

If the troubleshooting procedures of Section 6.7 indicate a faulty Deflection Board, Z-Amp Board, or Power Supply Board, always verify that the Curve Board output signals are functioning properly (see Section 6.8) before connecting the Curve Board to a new replacement board(s). A defective Curve Board can damage other display subsection boards.

6.4.2. Signal Processing and Control Boards

If the troubleshooting procedures of Section 6.7 indicate a faulty signal processing and control board, check the VME connectors on the board for bent pins and proper configuration of jumpers, prior to PC board replacement. Refer to Appendix C for jumper configurations.

6.5. Signal Summary

Table 6-3 lists the test points and signals used for troubleshooting a 1280 or 1281.

This signal summary is intended for quick reference purposes only. The troubleshooting procedures described in Section 6.7 should be used as the primary source of information for troubleshooting a problem within a 1280 or 1281.

WARNING: Hazardous voltages are present while probing signals listed in Table 6-3. Always turn power OFF whenever connecting/disconnecting PC boards and cables, checking and replacing fuses, or connecting and disconnecting equipment probes to or from test points.

The high-voltage circuitry retains lethal voltage for approximately 30 seconds after the monitor has been switched OFF.

6.6. Troubleshooting Flowchart

The troubleshooting flow chart in Figure 6-1 on pages 7a thru 7e, illustrates a process for isolating defective PC boards or subassemblies. The chart is intended as a quick reference only.

The troubleshooting procedures outlined in Section 6.7 should be used as the

primary source of information for diagnosing a problem with a 1280/1281.

NOTE: The numbers given in the flow chart of Figure 6-1 correspond to the step numbers of the step-by-step troubleshooting procedures of Section 6.7.

6.7. Troubleshooting Procedures

The procedures in this Section require that the monitor be opened. Refer to Chapter 4 for step-by-step instructions for opening and closing the monitor, and procedures for removing and installing replaceable parts.

Refer directly to the Section below that most closely describes the symptom the monitor is exhibiting.

NOTE: Throughout the following procedures, except where noted, connect the negative (reference) lead of oscilloscope or DVM to chassis ground.

6.7A No Display

1. Is green power LED indicator ON?

- Yes: Go to Step 17.
- No: Continue.

NOTE: If green power LED indicator is ON and monitor is making a continuous error tone, refer to Section 6.7E.

2. Does green power LED indicator light up at all, or momentarily, each time power is switched ON?

- Yes: Go to Step 7.
- No: Check power source outlet and line cord, and continue troubleshooting procedures.

3. Turn monitor power OFF. Check fuses in Power Input Module. Are both fuses intact?

- Yes: Continue.
- No: Replace defective fuse(s). Refer to spare parts listing, Appendix A.

Turn monitor power ON. If fuses do not blow, go to Functional Verification, Chapter 5.

If either fuse blows turn power OFF. Disconnect the Power Input Module from the Power Supply Board. Replace blown fuses and turn power to ON. If the fuses blow, replace the Power Input Module and go to Functional Verification, Chapter 5.

If fuses do not blow, turn power OFF, reconnect the Power Input Module to the Power Supply Board. Check that connector X4 on the Power Supply Board is configured for the on-site line voltage as illustrated in Appendix C.

Turn power ON. If fuses blow, replace Power Supply Board and go to Functional Verification, Chapter 5.

4. Turn monitor power OFF and disconnect the Power Input Module from the Power Supply.

Turn main monitor power ON. Use a DVM to measure output voltage of Power Input Module (brown lead = ac line, blue lead = ac neutral). Does the voltage match the line voltage?

- Yes: Continue.
- No: Replace the Power Input Module and go to Functional Verification, Chapter 5.

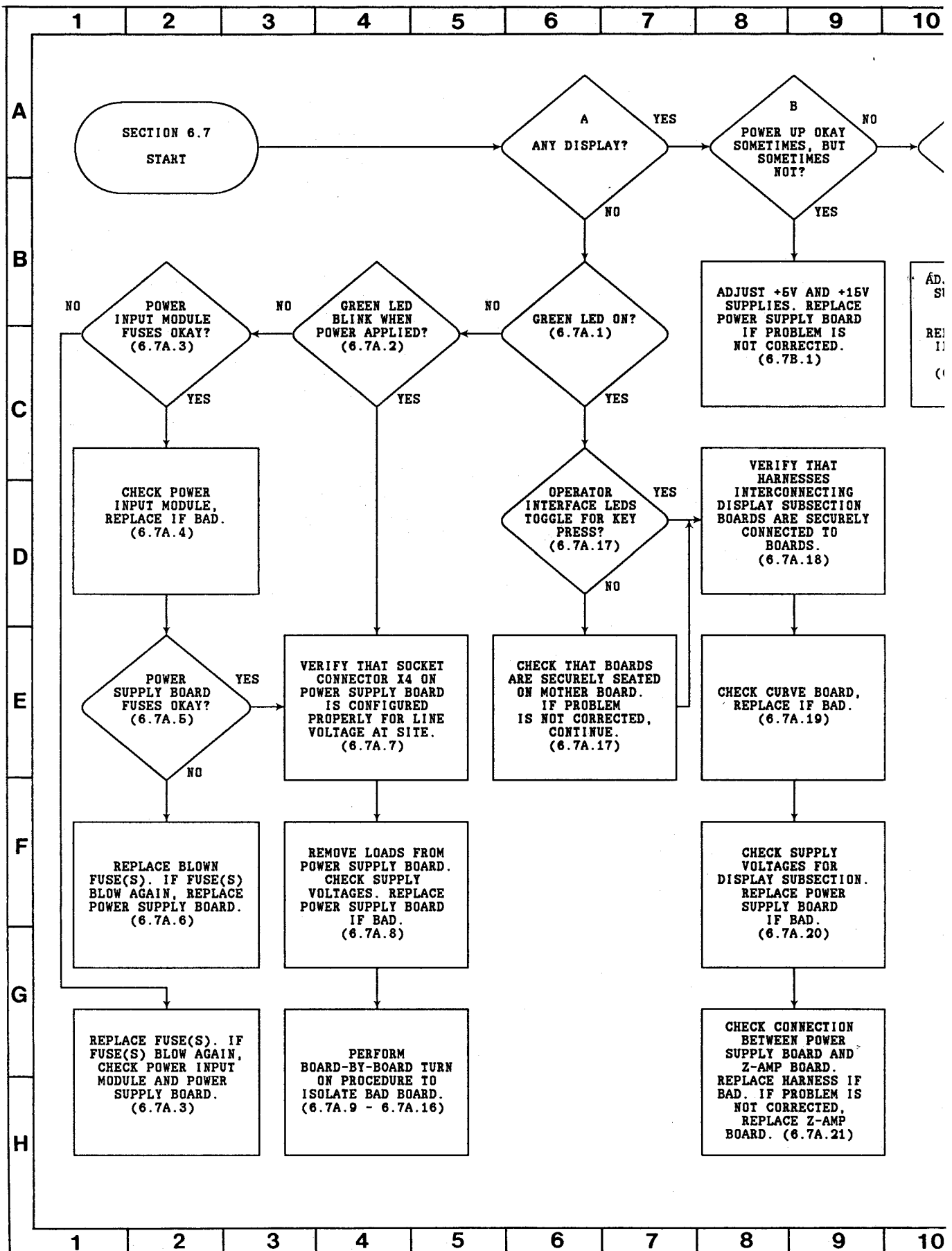
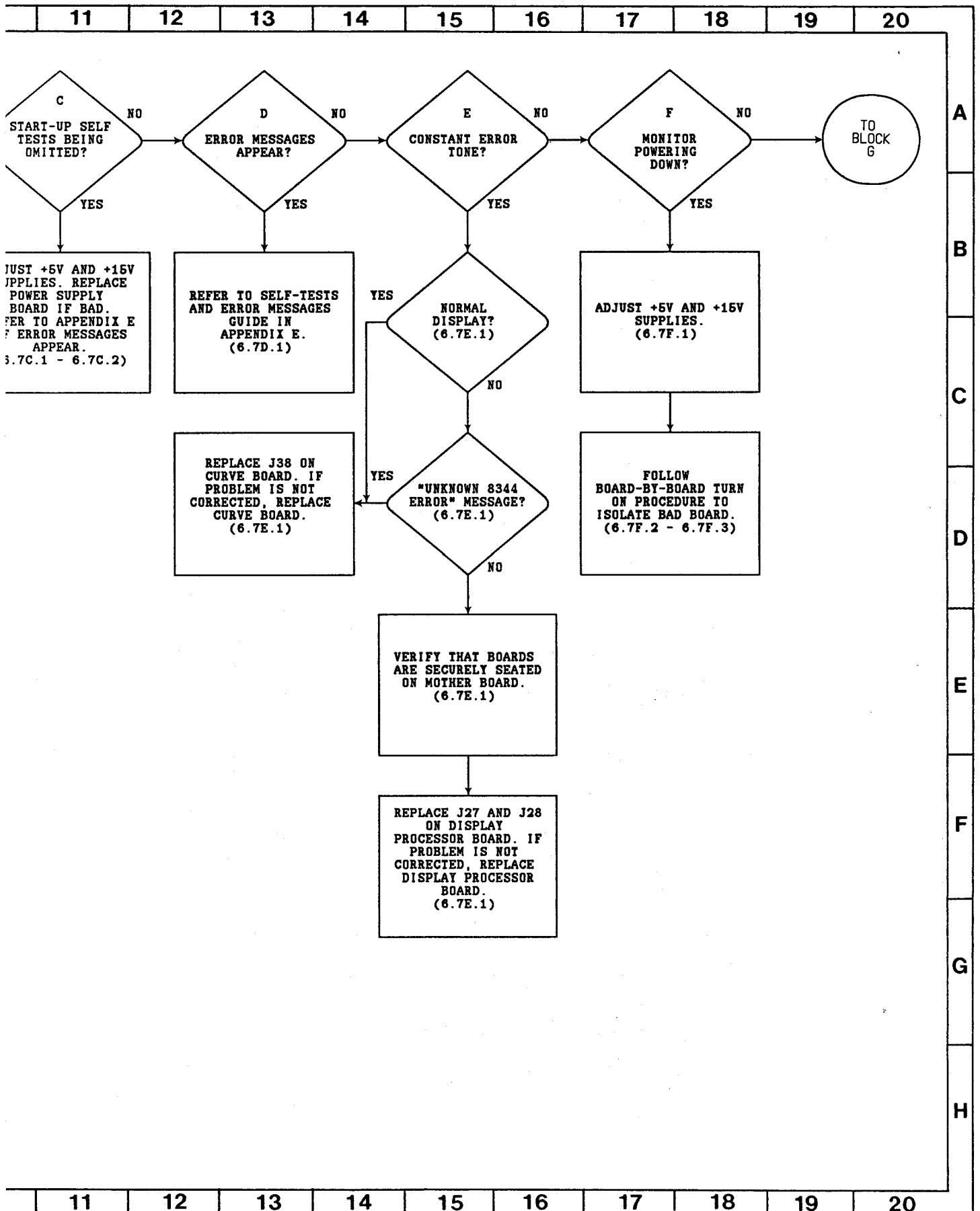

Figure 6-1. Troubleshooting Flow-chart, Sheet 1 of 5

System SIRECUST 1280/1281 Bedside Monitor - Service Manual



System SIRECUST 1280/1281 Bedside Monitor - Service Manual

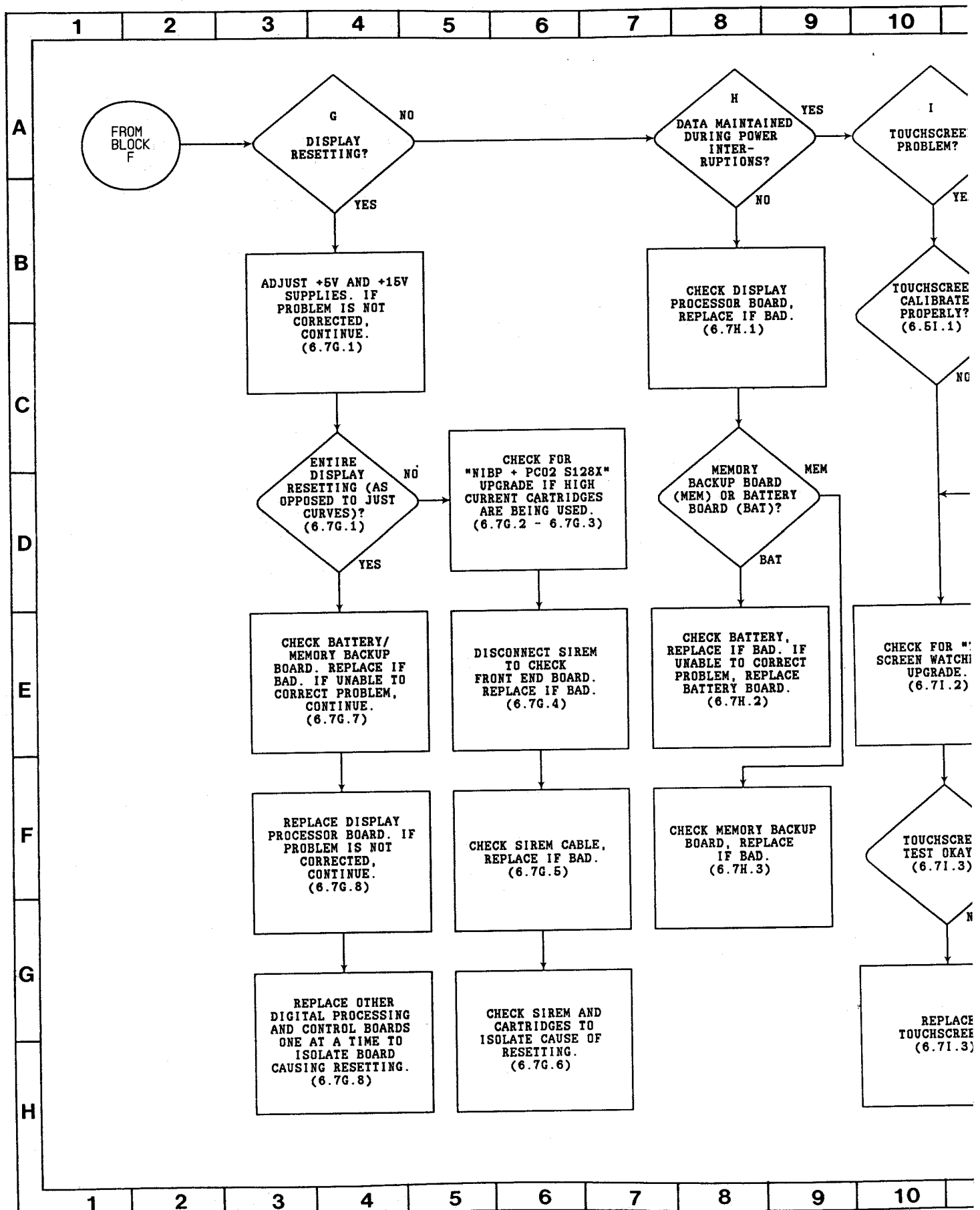
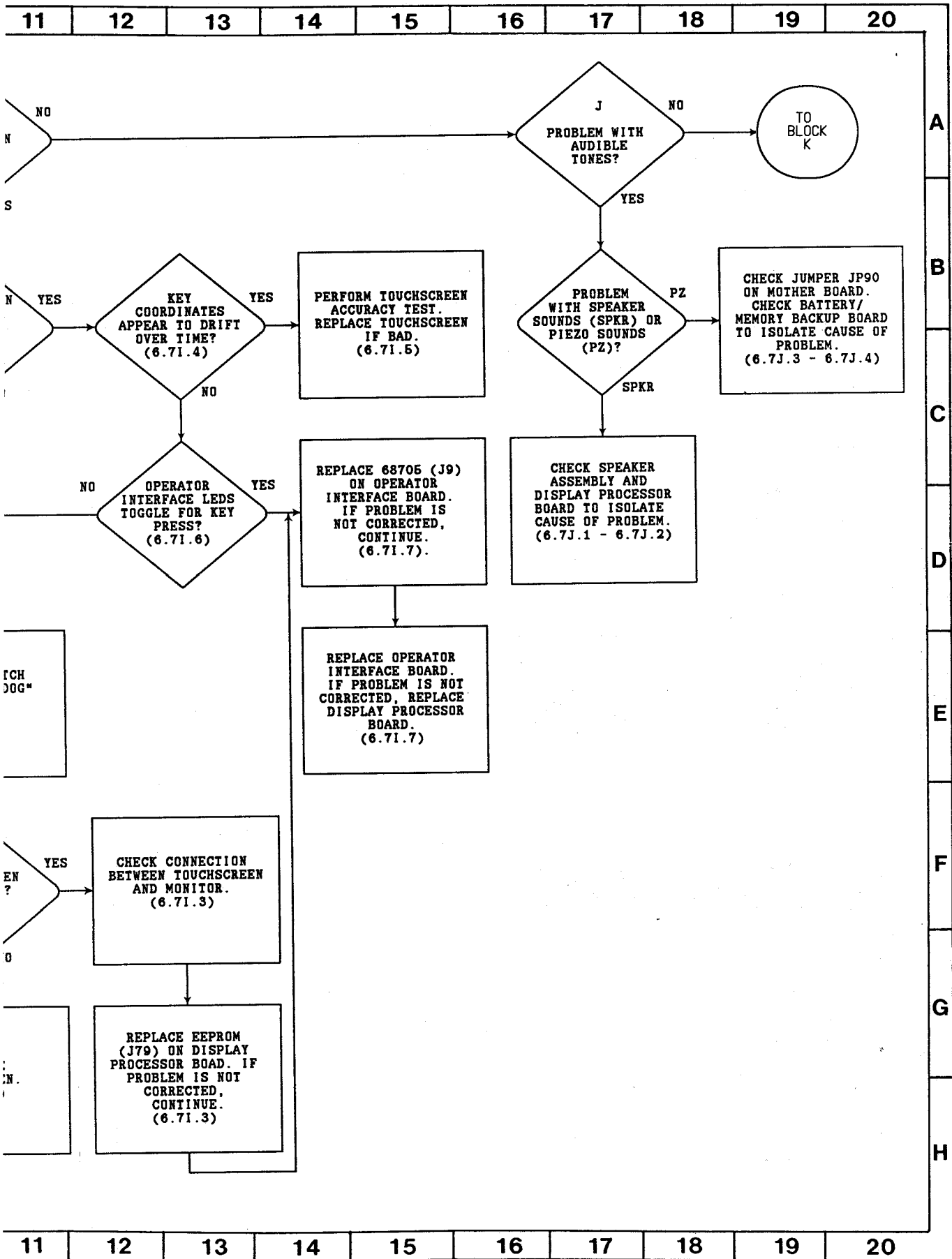

Figure 6-1. Troubleshooting Flow-chart, Sheet 2 of 5



A
B
C
D
E
F
G
H

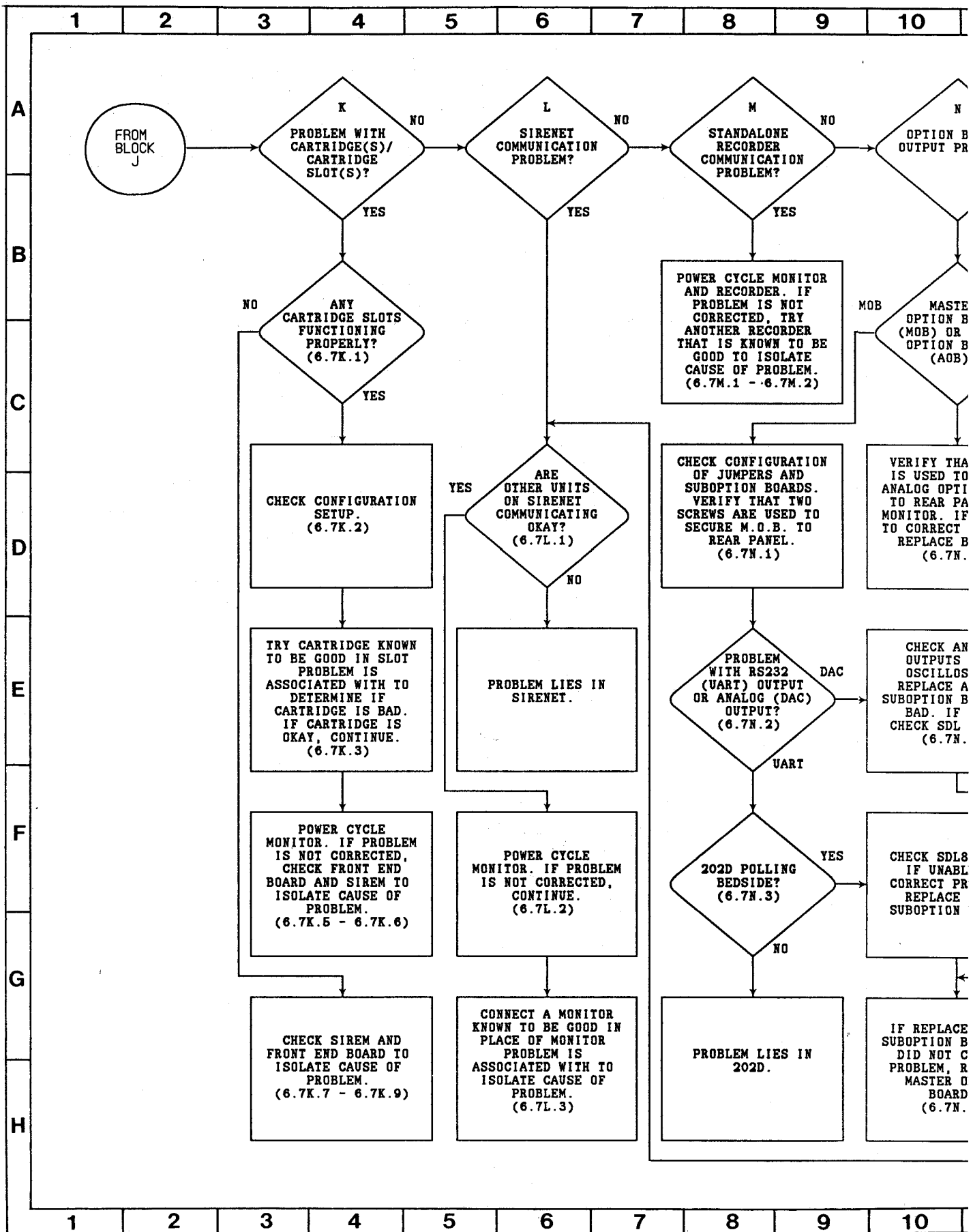
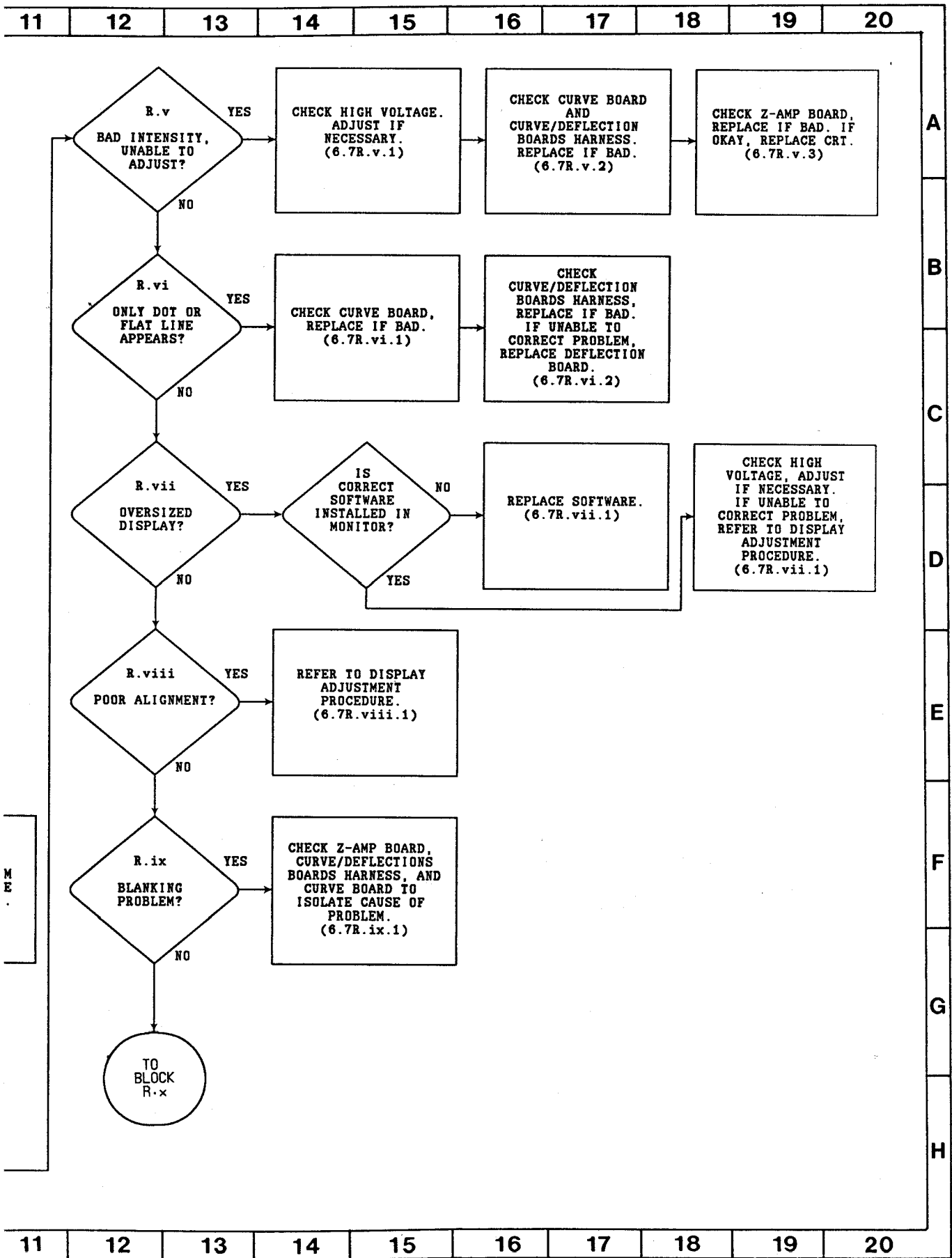

Figure 6-1. Troubleshooting Flow-chart, Sheet 3 of 5



System SIRECUST 1280/1281 Bedside Monitor - Service Manual

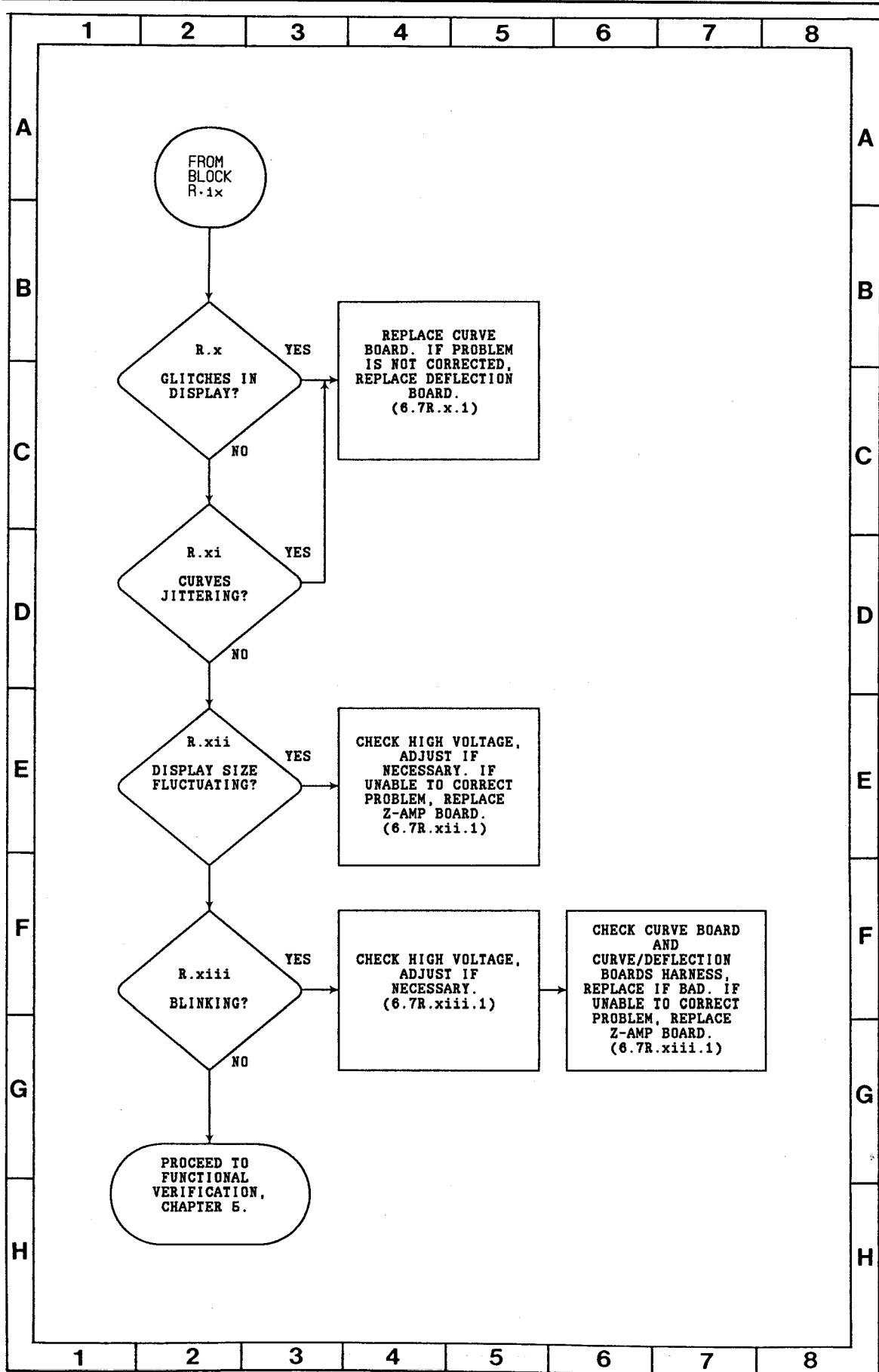

Figure 6-1.

This page intentionally left blank.

System SIRECUST 1280/1281 Bedside Monitor - Service Manual

5. Turn power OFF. Check fuses F1 and F2 on Power Supply Board. Are both fuses intact?

- Yes: Go to Step 7.
- No: Replace defective fuses. Refer to spare parts listing, Appendix A, and continue.

6. Turn power ON. Does F1 and/or F2 blow?

- Yes: Replace Power Supply Board and go to Chapter 5.
- No: Go to Functional Verification, Chapter 5.

7. Turn power OFF. Check connector X4 on Power Supply Board. Is X4 configured properly for line voltage at site?

- Yes: Continue.
- No: Reconfigure X4 and go to Functional Verification, Chapter 5.

8. Turn power OFF and disconnect X1, X2, and X3 from Power Supply Board. Turn power ON. Measure voltages at test points given in Table 6-4. Are supply voltages in accordance with the values given in the Table?

NOTE: This is not a quantitative test. It is a test only to check if the Power Supply Board outputs are functional. Voltages at each test point can vary slightly from the values indicated in the table, since the supply voltages are slightly higher when loads X1, X2, and X3 are disconnected.

- Yes: Continue.
- No: Replace Power Supply Board and proceed to Functional Verification, Chapter 5.

NOTE: Use of the Power Supply Board extender harness provides easy access to test points indicated in Table 6-4.

9. Turn power OFF, and

- a. Disconnect X3 and X4 on the Z-Amp Board.
- b. Disconnect X3 and X4 (1281) or X3 and X5 (1280) on the Deflection Board.
- c. Disconnect X7 and X8 on the Curve Board.
- d. Reconnect X1, X2, and X3 to the Power Supply Board.
- e. Install VME Extender Board in an empty Motherboard slot.
- f. Turn power ON, and measure +5V supply at TP2, pin A-32 on VME Extender Board.

Measure -15V supply at TP2, pin A-31 on VME Extender Board.

Are both the +5V and -15V supplies functional?

- Yes: Go to Step 15.
- No: Continue.

Table 6-4. Power Supply Board Test Points

TEST POINT	1280	1281
X1 pin 6	+5V	+5V
X2 pin 1	-15V	-15V
X2 pin 2	-5V	-5V
X3 pin 3	+25V	+29V (rev ≤ 2L) +25V (rev ≥ 2M)
X3 pin 4	+15V	+15V
X3 pin 7	-20V	-20V
X3 pin 8	-55V	-80V
X3 pin 9	---	-25V

SIEMENS Art. No. 87 92 467 E2502 A140
Power Supply boards of revision level 2
have +24V supplies, not +25V.

10. Turn power OFF. Remove any of the following PC boards that are installed in the monitor:

- Front End Board
- Display Processor Board
- Curve Board
- Line Driver Board
- Memory Extension Board
- Master Option Board
- Analog Option Board
- Clock Board

NOTE: Not all 1280/1281 bedside monitors are fitted with Line Driver Boards, Memory Extension Boards, Master Option Boards, Analog Option Boards, or Clock Boards.

Disconnect the Operator Interface Board ribbon cable from X7 on the Motherboard.

Turn power ON. Repeat measurements of +5V, and -15V supplies (refer to Step 9). Are supply voltages within specifications?

- Yes: Go to Step 12.
- No: Continue.

11. Turn power OFF, and disconnect Battery/Memory Backup Board from Motherboard. Turn power ON. Repeat measurement of +5V supply (refer to Step 9). Is voltage within specifications?

- Yes: Replace Battery/Memory Backup Board and go to Functional Verification, Chapter 5.
- No: Replace Motherboard and go to Functional Verification, Chapter 5.

12. Turn power OFF, and reconnect the Operator Interface Board ribbon cable to X7 on the Motherboard. Turn power ON. Does

power LED on front panel illuminate?

- Yes: Repeat measurement of -15V supply (refer to Step 9).

If voltage is NOT within specifications, replace Operator Interface Board and proceed to Functional Verification, Chapter 5. If voltage is okay, continue.

- No: Replace Operator Interface Board and go to Functional Verification, Chapter 5.

13. Turn power OFF, and reinstall Display Processor Board into the monitor. Turn power ON. Repeat measurements of +5V and -15V supplies refer to Step 9. Are supply voltages within specifications?

- Yes: Continue.
- No: Replace Display Processor Board and go to Functional Verification, Chapter 5.

14. Repeat Step 13 for each of the following PC boards:

- Front End Board
- Curve Board
- Line Driver Board
- Memory Extension Board
- Master Option Board
- Analog Option Board
- Clock Board

If the installation of any PC board causes supply voltages to shut down, replace that PC board and go to Functional Verification, Chapter 5.

15. Turn power OFF. Reconnect supply voltages to Deflection Board via X3 and X4 (1281), or X3 and X5 (1280).

Turn power ON. Repeat measurement of +5V supply (refer to Step 9 for possible test locations).

Is +5V supply okay?

- Yes: Continue.
 - No: Replace Deflection Board and go to Functional Verification, Chapter 5.
16. Turn power OFF. Reconnect X3 and X4 (supply voltages) to the Z-Amp Board. Turn power ON.

Repeat measurement of +5V supply (refer to Step 9). If +5V supply is not okay, replace Z-Amp Board and proceed to Functional Verification, Chapter 5.

17. Do the LEDs on Operator Interface Board toggle (change state) each time a key is pressed?

- Yes: Continue.
- No: Turn power OFF.
 - Assure that all PC boards are securely seated into the Motherboard.
 - Turn power ON.
 - If problem is corrected proceed to Functional Verification, Chapter 5. Otherwise, continue.

18. With power OFF, check that the plugs on the harnesses interconnecting the display subsection boards are securely plugged in:

- X7, and X8 on Curve Board.
- X1, X2 and X4 on Z-Amp Board.
- X1, X2 and X3 on Power Supply Board.

Check that the CRT socket end cap is securely connected to CRT.

Has correct operation been restored?

- Yes: Proceed to Functional Verification, Chapter 5.

- No: Continue.

19. a. Turn power OFF. Disconnect X7 and X8 from Curve Board.
- b. Disconnect SIREM(s) (if connected) from monitor.
- c. Turn the power ON and wait for monitor to complete the start-up self tests.

NOTE: The LEDs on the Operator Interface Board indicate the binary number of the start-up self test being performed. The start-up self tests have been completed when the LEDs stop counting.

- d. After the completion of the self tests, check the following signals on the Curve Board:

Z signal at X8-1, and BLANKING signal at X8-5.

- e. Using the signal at X7-9 to trigger the oscilloscope, compare the Z signal to Figure 6-3 for a 1280, or Figure 6-4 for a 1281.

- f. Set oscilloscope to 5V/div. and 2ms/div. to check BLANKING.

The BLANKING signal should be low at 0V.

Press DISPLAY SET-UP fixed key. The BLANKING signal should now have groups of high frequency +5V pulses.

Are signals within specifications?

- Yes: Continue.
- No: Check Curve/Deflection Boards harness for continuity between X8 on Curve Board and X1/X2 on Z-Amp Board.

Refer to Appendix B, Figure B-1.1 or B-1.2, (monitor wiring diagrams). Replace harness if bad.

If unable to correct problem, replace Curve Board.

Proceed to Functional Verification, Chapter 5.

20. Turn power OFF, and disconnect X3 from Power Supply Board.

Turn power ON and measure supply voltages at X3-3, X3-7, X3-8, and X3-9. Refer to Table 6-3.

Are supply voltages okay?

- Yes: Continue.
- No: Replace the Power Supply Board and proceed to Functional Verification, Chapter 5.

21. Turn power OFF, and check Power Supply cable assembly for continuity between X3 at Power Supply Board and X4 at Z-Amp Board.

Check Curve/Deflection Boards harness for continuity between X8 on Curve Board and X1/X2 on Z-Amp Board, and between X7 on Curve Board and X2 on Deflection Board. Refer to Appendix B, Figure B-1.1 or B-1.2, (monitor wiring diagrams).

Are cable harnesses assemblies okay?

- Yes: Replace Z-Amp Board. If problem is not corrected, replace CRT.

Proceed to Functional Verification, Chapter 5.

- No: Replace bad harness and proceed to Functional Verification, Chapter 5.

6.7B. Monitor Powers Up Properly Sometimes and Sometimes Does Not

1. Turn power OFF. Disconnect X1, X2, and X3 loads from the Power Supply Board.

Adjust R3 (+5V adjustment potentiometer) for $5.20 \pm 0.01V$ at X1-2 (chassis = GND).

Adjust R14 (+15V adjustment potentiometer) for $15.80 \pm 0.03V$ at X2-4.

Turn power OFF. Reconnect X1, X2, and X3. Turn power ON and OFF several times. Wait for piezo sound to stop each time power is turned OFF.

Does monitor power up each time?

- Yes: Adjust +5V and +15V supplies. See Chapter 7, Section 7.1., and proceed to Functional Verification, Chapter 5.
- No: Replace Power Supply Board and go to Functional Verification, Chapter 5.

6.7C. Monitor Omits Start-Up Self Tests

1. Adjust +5V and +15V supplies. Refer to Chapter 7, Section 7.1.

Are start-up self tests performed each time monitor is turned ON?

- Yes: Proceed to Functional Verification, Chapter 5.
- No: Continue.

2. Replace Power Supply Board.

Does monitor power up correctly and pass all self tests?

- Yes: Proceed to Functional Verification, Chapter 5.
- No: Refer to Appendix E, System SIRECUST Self Test and Error Messages, for the software version installed in the monitor.

6.7D. Error Messages

1. If hardware error messages are exhibited during self tests or during normal operation, refer to Appendix E, System SIRECUST Self Test and Error Messages, for the installed software version.

6.7E. Monitor Produces a Constant Error Tone

1. Is there a normal display, or an **UNKNOWN 8344 ERROR** message in the top left of the screen?

- Yes: Turn power OFF and remove Curve Board from monitor.

Check that EPROM J38 is installed correctly and that no pins are bent.

Check connectors X1 and X2 to assure that no pins are bent.

Reinstall Curve Board, assuring that the board

seats securely on Motherboard. If problem is corrected, proceed to Functional Verification, Chapter 5.

If unable to restore correct operation, replace EPROM J38. If problem is corrected, proceed to Functional Verification, Chapter 5.

If still unable to restore correct operation, replace the Curve Board, and proceed to Functional Verification, Chapter 5.

- No: Check that all signal processing and control PC boards are securely seated on Motherboard.

If unable to correct problem, turn power OFF, and remove Display Processor Board from unit.

Check that J27 and J28 are installed correctly and that no pins are bent.

Check connectors X1 and X2 to assure that no pins are bent.

Reinstall Display Processor Board, assuring that board seats securely on Motherboard. If problem is corrected, proceed to Functional Verification, Chapter 5.

If unable to restore correct operation, replace J27 and J28. If problem is corrected, proceed to Functional Verification, Chapter 5.

If still unable to restore correct operation, replace

Display Processor Board, and proceed to Functional Verification, Chapter 5.

6.7F. Monitor Powers Down During Start-Up Self Tests or During Normal Operation

1. Adjust +5V and +15V supplies
Refer to Chapter 7, Section 7.1.

Does monitor operate correctly without powering down?

- Yes: Proceed to Functional Verification, Chapter 5.
 - No: Continue.
2. Follow board-by-board turn on procedure (refer to Section 6.7A, Steps 8 - 16) to isolate a PC board causing shut down.

Replace PC board, and proceed to Functional Verification, Chapter 5.

NOTE: If Section 6.7A, Steps 14 - 15 indicate Curve Board (in 1281) or Deflection Board (in 1280) is causing the shut down, refer to Step 3 below prior to replacing the board.

3. Adjust RETRACE potentiometer. Poorly set RETRACE can cause shutdown. Refer to Calibration/Adjustment, Chapter 7, Section 7.3.2.

Does monitor operate correctly without powering down?

- Yes: Proceed to Functional Verification, Chapter 5.
- No: Replace Curve Board, if 1281, or replace the Deflection Board, if 1280. Proceed to Functional Verification, Chapter 5.

6.7G. Display Resets

This Section applies if only the display is resetting. If monitor is powering down and initiating start-up self tests, refer to Section 6.7F.

1. Adjust +5V and +15V supplies
Refer to Chapter 7, Section 7.1. Is problem corrected?

- Yes: Proceed to Functional Verification, Chapter 5.
- No: If entire display is resetting, proceed to Step 7.

If only curves and parameters are resetting, as if cartridges have been removed and reinserted, continue.

2. Are high current cartridges being used, such as NIBP or PCO₂?

- Yes: Continue.
- No: Proceed to Step 4.

3. Check Front End Board revision level. Is the Front End Board of revision $\leq 1K$ or $\leq 2H$?

- Yes: Check for label on solder side of Front End Board to determine if ECO #4549 (NIBP + pCO₂ upgrade) has been installed. If not, install ECO #4549, NIBP + PCO₂ upgrade kit, Art. No. 45 34 525 EE52U.

If problem is corrected, proceed to Functional Verification, Chapter 5.

If problem is not corrected, continue.

- No: Continue.

System SIRECUST 1280/1281 Bedside Monitor - Service Manual

4. Disconnect SIREM cable from monitor.

CAUTION: Turn monitor power OFF whenever connecting/disconnecting SIREM cable.

Does resetting stop?

- Yes: Continue.
- No: Replace Front End Board, and proceed to Functional Verification, Chapter 5.

5. Disconnect SIREM cable from SIREM. Reconnect cable to monitor. Does resetting occur?

- Yes: Replace SIREM cable, and proceed to Functional Verification, Chapter 5.
- No: Continue.

6. Remove all cartridges from SIREM. Reconnect cable from SIREM to monitor. Does resetting occur?

- Yes: SIREM is defective. Refer to SIREM Service Manual.
- No: Insert cartridges one at a time to determine which cartridge is causing resetting. Replace faulty cartridge.

7. Place Display Processor Board on VME Extender Board.

Use oscilloscope to view AC FAIL signal at TP1, pin A-20 on VME Extender Board. Is AC FAIL dropping LOW (0V) at onset of display resetting?

- Yes: Replace Battery/Memory Backup Board. Go to Functional Verification, Chapter 5.
- No: Continue.

8. Replace Display Processor. Is problem corrected?

- Yes: Proceed to Functional Verification, Chapter 5.
- No: Replace each of the other digital processing and control PC boards one at a time. If problem is not corrected, replace Power Supply Board, and go to Functional Verification, Chapter 5.

6.7H Data Not Maintained During Power Interruptions

This section applies if information saved in SRAM, such as trend data and alarm limits, is not maintained during power interruptions (up to 10 minutes in length), but other monitor functions are operating properly.

1. a. Turn power OFF.
- b. Place Display Processor Board on VME Extender Board.
- c. Use an oscilloscope or DVM to check the BCHRG signal at TP2, pin C16 on VME Extender Board. When monitor is powered ON, BCHRG should be LOW at 0V for several seconds, then go HIGH to +5V for approximately one minute, then return to LOW.

Is BCHRG okay?

- Yes: Proceed to Step 2 if monitor is equipped with an A931 Battery Board.

Proceed to Step 3 if monitor is equipped with an A933 Memory Backup Board.

- No: Replace Display Processor Board, and proceed to Functional Verification, Chapter 5.
2. Turn power OFF.
- Disconnect battery connector X1 from connector JP1 on Battery Board. Use an oscilloscope or a DVM to check the battery charge signal, BATR+, at JP1, pin 2.
- When monitor power is turned ON, the piezo alarm will sound after several seconds.
- Does BATR+ rise to +15V after piezo alarm sounds?
- Yes: Replace battery. Proceed to Functional Verification, Chapter 5.
 - No: Replace Battery Board with Memory Backup Board, A933, and proceed to Functional Verification, Chapter 5.
3. Turn power OFF. Set up DVM or oscilloscope to check voltage at TP1 on Memory Backup Board.
- Turn power ON. +5V should be present at TP1.
- Turn power OFF. TP1 should remain at +5V for a minimum of 10 minutes.
- If voltage levels measured at TP1 are improper, replace Memory Backup Board, and proceed to Functional Verification, Chapter 5.
- 6.7I. TouchScreen Drifting or Not Functioning Properly**
1. Initiate TouchScreen calibration by pressing anywhere in the left half of the TouchScreen immediately following power up self-tests.
- Follow screen prompts for calibrating TouchScreen.
- Does the TouchScreen calibrate properly?
- Yes: Go to Step 4.
 - No: Continue.
2. Does the monitor have an A292 Operator Interface Board, Art. No. 12 66 308 E2500 installed?
- Yes: Continue.
 - No: Check solder side of board for label indicating that ECO #5214, #5216, or #5217 (TCH SCREEN WATCHDOG upgrade) has been installed.
- If not, install TouchScreen Watchdog upgrade. Order upgrade kit Art. No. 12 66 431 E2500). If problem is corrected, proceed to Functional Verification, Chapter 5.
- If problem is not corrected, continue.
3. TouchScreen Test:
- a. Turn power OFF.
 - b. Remove Front Panel.
 - c. Disconnect the TouchScreen from the Operator Interface Board at X2.
 - d. Using a DVM, measure the resistance across each of the pin combinations indicated in Table 6-5. Press the TouchScreen, and compare readings when you are pressing the TouchScreen to readings when you are not pressing the TouchScreen.

System SIRECUST 1280/1281 Bedside Monitor - Service Manual

Table 6-5. TouchScreen Test Values

TEST POINT	PRESSED	NOT PRESSED
pin 1 → 5	6-14Ω (typical)	6-14Ω (typical)
pin 2 → 3	20-50Ω (typical)	20-50Ω (typical)
pin 1 → 2	resistance	
pin 1 → 3	corresponding	no
pin 2 → 5	to pressure	continuity
pin 3 → 5	point	

NOTE: The pin numbers in Table 6-5 refer to the connector on the TouchScreen wiring harness. See Figure 6-2.

- e. Are TouchScreen resistances within specifications?
 - Yes: Reinstall the Front Panel.

If problem is corrected, proceed to Functional Verification, Chapter 5.

If problem is not corrected, replace EEPROM J79 on Display Processor Board.

If problem is corrected, proceed to Functional Verification, Chapter 5.

If problem is not corrected, proceed to Step 7.
 - No: Replace TouchScreen, and proceed to Functional Verification, Chapter 5.
4. Do key coordinates appear to drift over time?
 - Yes: Continue.
 - No: Go to Step 6.
5. TouchScreen Accuracy Test:

- a. Turn power OFF and allow monitor to cool down for 2 hrs.
- b. Turn power ON. Enter the touch values test mode by pressing DISPLAY TOUCH VALUES key in the FIELD SERVICE menu.

NOTE: In the touch values test mode, the coordinate values of TouchScreen key-presses are displayed on the screen. This test is used to determine if the values are within specified limits.

- c. Press each corner of the screen three times. If the displayed horizontal or vertical coordinates deviate from the limits specified in Figure 6-5 by more than 3 counts, replace TouchScreen, and proceed to Functional Verification, Chapter 5.

Repeat this procedure after monitor has warmed up for 2 hours.

NOTE: The touch coordinate display shows the horizontal coordinates (XX) followed by the vertical coordinates (YY).

e.g. TXX YY

The letter "T" (touch) precedes the coordinates when the TouchScreen is being operated. The letter "R" (release) precedes the coordinates when the TouchScreen is not being operated.

If the ambient light level changes, the touch coordinate display will be replaced by the ambient light level preceded by the letter "L". This display will be replaced by the touch coordinate values of the press of the TouchScreen.

6. Do the LEDs on Operator Interface Board toggle (change state) for each key press?
 - Yes: Continue.

- No: Inspect for installation of TouchScreen Watchdog upgrade. Refer to Step 2, and install upgrade if not previously installed.

Perform TouchScreen test (if not previously performed). Refer to Step 3.

Replace TouchScreen if necessary. If problem is corrected, proceed to Functional Verification, Chapter 5.

If unable to restore correct operation, continue.

7. Replace the 68705 chip, J9, on Operator Interface Board. If problem is corrected, proceed to Functional Verification, Chapter 5.

If problem is not corrected, replace Operator Interface Board. If replacing the board corrects the problem, proceed to Functional Verification, Chapter 5.

If the problem is still not corrected, replace Display Processor Board. Proceed to Functional Verification, Chapter 5.

6.7J. Problem With Speaker Tones

For speaker tone problems (key press sounds, alarms, etc.) go to Step 1.

For piezo sound problems (power down sound), go to Step 3.

1. Is Speaker Assembly securely connected to X6 on Mother board?
 - Yes: Continue.
 - No: Connect Speaker Assy. Proceed to Functional Verification, Chapter 5.

2.
 - a. Disconnect Speaker Assembly from X6.
 - b. Connect oscilloscope probe to X6, pin 2.
 - c. Connect SIREM to monitor.

Insert LIM in SIREM, but do not connect any input cables to the LIM.
 - d. Turn power ON. After monitor completes start-up self tests, verify that heart rate alarm is ON (refer to 1280/1281 Operating Instructions).

After heart rate parameter goes into alarm, compare BEEPER signal at X6, pin 2 to Figure 6-6.

Is signal okay?

- Yes: Replace Speaker Assy. Proceed to Functional Verification, Chapter 5.
 - No: Replace Display Processor Board. Proceed to Functional Verification, Chapter 5.
3. Turn main power OFF.

Is shorting jumper installed between pins 1 and 2 of JP90 on Motherboard?

 - Yes: Continue.
 - No: Install a shorting jumper. Proceed to Functional Verification, Chapter 5.
 4. Turn power Off.

Remove shorting jumper and connect positive lead of DVM to JP90, pin 1.

System SIRECUST 1280/1281 Bedside Monitor - Service Manual

Turn power ON then OFF.

Does PIEZO signal at JP90 pin 1 go high to +5V for approximately 13 seconds?

- Yes: Replace Motherboard. Proceed to Functional Verification, Chapter 5.
- No: Replace Battery/Memory Back-Up Board. Reinstall shorting jumper at JP90. Proceed to Functional Verification, Chapter 5.

6.7K. Cartridge(s) Not Recognized or Cartridge Slots Non-functional

NOTE: If insertion of a high current cartridge (such as NIBP or PCO₂) is causing parameter and curve displays to reset, refer to Section 6.7G, Steps 1 - 3.

NOTE: X16 is the connector for SIREM 1, X17 is the connector for SIREM 2. In the following steps, signals should be probed at the connector corresponding to the SIREM containing the cartridge(s)/slot(s) with which the problem is associated.

1. Are any cartridge slots functioning properly?
 - Yes: Continue.
 - No: Go to Step 7.
2. Refer to monitor Operating Instructions for stipulations on cartridge operation in the various configuration setups (e.g. NIBP and SaO₂ are supported only in AUTO CONFIG in VEO software). If problem persists, continue.
3. Insert a known working cartridge into problem slot of the SIREM.

Does the monitor properly acknowledge the known working cartridge?

- Yes: Cartridge that was not acknowledged by monitor is faulty.

- No: Continue.

4. Turn monitor power OFF. Wait for piezo sound to stop, then turn the power back ON.

Does monitor properly acknowledge the cartridge?

- Yes: Proceed to Functional Verification, Chapter 5.

- No: Continue.

5. a. Disconnect the SIREM from the monitor.

CAUTION: Turn monitor power OFF whenever connecting or disconnecting the SIREM.

- b. Probe the clock signal, CLK, for the non-functional cartridge slot at the connector on the rear panel of the monitor.

Refer to Table 6-6. Reference oscilloscope to pin indicated in this table.

NOTE: A LIM communicates via the upper of the two slots in which it is inserted. For example, with the LIM inserted in slots 1 and 2 (top two slots), probe signals corresponding to slot 1.

- c. Compare clock signal to Figure 6-7. All clock signals should be identical. Is signal okay?

Table 6-6. Clock Signals for SIREM

SIREM SLOT	SIGNAL PIN	REF. PIN
1	1	2
2	3	4
3	5	6
4	7	8

Table 6-7. Differential Signals from SIREM

SIREM SLOT	SIGNAL PIN	REF. PIN
1	9	10
2	9	10
3	11	12
4	11	12

- Yes: Continue.
- No: Replace Front End Board. Proceed to Functional Verification, Chapter 5.

6. a. Turn power OFF.
- b. Place Front End Board on VME Extender Board.
- c. Connect the SIREM to the appropriate Front End Board connector.
- d. Remove cartridges from SIREM.
- e. Check DCS (differential cartridge signal) returning from nonfunctioning cartridge slot at pins of SIREM input connector on Front End Board.

Refer to Table 6-7. Reference oscilloscope to pin indicated in the table.

- f. DCS should be high at +5V.
Insert a known good cartridge into the nonfunctioning slot. DCS should show pulsing. Is DCS okay?
- Yes: Replace Front End Board. Proceed to Functional Verification, Chapter 5.
 - No: Check SIREM cable for continuity. Refer to SIREM Service Manual for wiring diagram. Replace the cable if

bad, and go to Functional Verification, Chapter 5.

If SIREM cable is good, SIREM is faulty. Refer to SIREM Service Manual.

7. Disconnect SIREM from monitor.

CAUTION: Turn monitor power OFF whenever connecting or disconnecting SIREM.

- a. Measure voltage across pin 21 (+15V EXT) and pin 24 (reference) at SIREM connector on rear panel of monitor.

Measured voltage should typically be +15.4V \pm 0.1V.

Adjust supply voltage if necessary. Refer to Chapter 7, Section 7.1. Is +15 V EXT okay?

- Yes: Continue.
 - No: Replace Front End Board. Proceed to Functional Verification, Chapter 5.
8. Check the following signals at the connector on the rear panel of the monitor corresponding to the nonfunctioning SIREM (either X16 or X17):

- CLK A (signal = pin 1, reference = pin 2)
- 25K (SYNC) (signal = pin 17, reference = pin 18).

Compare signals to Figures 6-7 and 6-8. Are signals okay?

- Yes: Continue.
- No: Replace Front End Board. Proceed to Functional Verification, Chapter 5.

9. Perform Step 6, but only for slot 1.

Is problem corrected?

6.7L. SIRENET Communication Problem

1. Are all other monitors/recorders on SIRENET communicating properly with central station?

- Yes: Continue.
- No: Problem exists in SIRENET.

2. Turn power OFF. Wait for piezo tone to stop, then turn power ON. Is problem corrected?

- Yes: Go to Functional Verification, Chapter 5.
- No: Continue.

3. Connect a substitute bedside monitor, known to communicate properly via SIRENET, to the bedside wallplate to which the malfunctioning monitor was connected. Use the same SDL4 cable that was used with the malfunctioning monitor.

Does the substitute bedside monitor communicate properly over SIRENET?

- Yes: Replace Curve Board. Proceed to Functional Verification, Chapter 5.
- No: Problem exists in SIRENET or SDL4 cable.

6.7M. Standalone Recorder Communication Problem

1. a. Turn monitor power OFF. Wait for piezo tone to stop, then turn power ON.

Power cycle the SIREDOC recorder, by powering OFF, and then to ON.

- Yes: Proceed to Functional Verification, Chapter 5.

- No: Continue.

2. Connect a substitute System SIRECUST bedside monitor with known good recorder communication in place of the malfunctioning monitor. Does the substitute monitor communicate properly with recorder?

- Yes: Replace Curve Board. Proceed to Functional Verification, Chapter 5.
- No: Problem exists in recorder or connecting SDL4 cable.

6.7N. Problem With Option Board Outputs

For problems with Master Option System, start at Step 1. For problems with 4-Ch Analog Output Boards, go to Step 7.

1. Check configuration of jumpers and sub-option boards on Master Option Board. See Appendix C.

Verify that the two screws used to secure Master Option Board to monitor rear panel are installed.

Do outputs function properly?

- Yes: Proceed to Functional Verification, Chapter 5.

- No: Continue.

2. Is there an RS232 UART problem, e.g. is 202D displaying:

NO MONITOR CONNECTED?

- Yes: Continue.
- No: Go to Step 4.

3. Is 202D emitting a pulse/poll on TD once every two seconds?

Refer to Section 8, steps D1 and D2, in System SIRECUST 202D Service Manual.

- Yes:
 - a. Check SDL 8 cable for continuity. Replace cable if bad.
 - b. If unable to restore correct operation, replace RS232 Serial Suboption Board.

Continue.

- No: Problem exists in 202D.

4. Is there a problem with analog outputs?

- Yes: Continue.
- No: Go to Step 6.

5. Use oscilloscope to check analog outputs at connectors on rear panel of monitor. Refer to Master Option Board Hardware Installation Instructions for output assignments.

Are all analog channels functioning properly?

NOTE: Connect SIREM to monitor. Insert cartridges in SIREM and connect simulator to cartridges. Use adequate number of cartridges to provide analog signals to each analog output channel.

- Yes: Check analog output SDL cable for continuity. Replace cable, if bad, and Continue.
- No: Replace Analog Suboption Board(s) corresponding to faulty analog output channels. Continue.

6. If replacing suboption board(s) did not restore correct operation, replace Master Option Board.

Proceed to Functional Verification, Chapter 5.

7. Verify that the screw used to secure 4-Channel Analog Output Board to rear panel of the monitor is installed.

If unable to correct problem, replace Analog Output Board.

Proceed to Functional Verification, Chapter 5.

6.7O. Time Not Being Updated By Central Station

1. Are other SIRENET communications functioning properly?
 - Yes: Replace EEPROM, J79, on Display Processor Board. Proceed to Functional Verification, Chapter 5.
 - No: Refer to Section 6.7L: SIRENET Communication Problem.

6.7P. Standalone Time Not Maintained Following Power Interruptions

This section applies when a standalone monitor has a Clock Board or MOB installed and the time of day is not maintained.

1. For Master Option Boards, verify that a shorting jumper connects X7 pins 2 and 3 to activate the battery. Continue.
2. Measure battery, B1, voltage. Is battery voltage $\geq 3.0V$?
 - Yes: Replace board. Proceed to Functional Verification, Chapter 5.

- No: Replace battery. Proceed to Functional Verification, Chapter 5.

6.7Q. Automatic Ambient Brightness Adjustment Not Functioning Properly

1. Verify that ambient light sensor is turned ON. Perform the ambient light sensor functional verification test. Refer to Chapter 5.

Does the monitor pass the test?

- Yes: Restore monitor to service.
- No: Continue

2. Measure voltage at J9, pin 23, on the Operator Interface Board.

Cover the ambient light sensor for 5 seconds, and then uncover.

Does measured voltage increase when sensor is covered, and decrease when sensor is uncovered?

- Yes: Replace J9. If problem is not corrected, replace the Display Processor Board.

Proceed to Functional Verification, Chapter 5.

- No: Replace Operator Interface Board. Proceed to Functional Verification, Chapter 5.

6.7R. Display Abnormality

NOTE: Refer to the following subsection topic that most closely describes the display abnormality your monitor is exhibiting.

Section R, Subsection topics:

- i. Color shutter malfunctioning.

- ii. Fold over.
- iii. Entire display appears in one area/field of screen.
- iv. Out of focus, unable to adjust.
- v. Intensity too bright or too dim, unable to adjust.
- vi. Only dot or flat line appears.
- vii. Oversized display
- viii. Poor alignment.
- ix. Blanking problem.
- x. Glitches in display.
- xi. Curves jittering.
- xii. Screen size fluctuating.
- xiii. Blinking.

6.7R.i. Color Shutter Malfunctioning

This applies if either one or both halves of a 1281 display are all green or all red.

1. Disconnect the front panel assembly.

Using an oscilloscope, observe the color shutter driver signals listed in Table 6-8, on Operator Interface Board connector X2. X2 interfaces to the front panel ribbon cable. Header pins are arranged

Table 6-8. Color Shutter Drive Signals

<u>Shutter Driver Signal</u>	<u>Connector Pin</u>
SH 4	X2, pin 10
SH 3	X2, pin 9
SH 2	X2, pin 8
SH 1	X2, pin 7

in descending order from 10 to 1, left to right. Also see Figure 6-2.

Compare each signal to Figure 6-9. Are all four driver signals identical to the figure?

- Yes: Replace color shutter. Proceed to Functional Verification, Chapter 5.
- No: Continue.

2. Place Curve Board on a VME Extender Board.

Observe Curve Board signal, LEFTR/G, at TP2 pin C-21 of the VME Extender Board.

Observe Curve Board signal, RIGHTR/G, at TP2 pin C-22 of VME Extender Board.

Compare each signal to Figure 6-10. Both signals should be identical.

Observe Curve Board signal SHCLK at TP2, pin C-23 of the VME Extender Board.

Compare signal to Figure 6-11.

Are signals okay?

- Yes: Replace Operator Interface Board. Proceed to Functional Verification, Chapter 5.
- No: Replace Curve Board. Proceed to Functional Verification, Chapter 5.

6.7R.ii. Fold Over

This section applies if bottom of display appears to be folded upward.

1. Adjust the deflection current with the RETRACE potentiometer on

the Curve Board, for the 1281, or the Deflection Board for the 1280. Refer to Chapter 7, Section 7.3.

Does the deflection current adjustment correct the fold over?

- Yes: Proceed to Functional Verification, Chapter 5.
- No: For 1281, replace the Curve Board, and proceed to Functional Verification, Chapter 5.

For 1280, replace the Deflection Board, and go to Functional Verification, Chapter 5.

6.7R.iii. Entire Display Appears In One Section of Screen.

Is monitor fitted with the correct software?

- Yes: Replace Curve Board. If problem persists, replace Deflection Board. Proceed to Functional Verification, Chapter 5.
- No: Replace software. Proceed to Functional Verification, Chapter 5.

6.7R.iv. Out of Focus, Unable to Adjust

This section applies if display is out of focus and cannot be properly focused with R40 on Z-Amp Board.

1. Check high voltage and adjust if necessary. Refer to Chapter 7, Section 7.2.

Is focus adjustable to acceptable level?

- Yes: Proceed to Functional Verification, Chapter 5.
- No: Continue.

System SIRECUST 1280/1281 Bedside Monitor - Service Manual

2. Adjust the intensity potentiometer, R3, on Z-Amp Board.

Is focus adjustable to acceptable level?

- Yes: Proceed to Functional Verification, Chapter 5.
- No: Replace Z-Amp Board. If problem persists replace CRT. Proceed to Functional Verification, Chapter 5.

6.7R.v. Intensity Too Bright or Too Dim, Unable to Adjust

This section applies if display intensity is too bright or too dim and cannot be adjusted with INTENSITY potentiometer R3 on Z-Amp Board.

1. Check high voltage and adjust if necessary. Refer to Chapter 7, Section 7.2.

Is intensity adjustable to acceptable level?

- Yes: Proceed to Functional Verification, Chapter 5.
- No: Continue.

2. Set monitor to display the alignment test pattern. To enter display alignment test pattern mode, press the following key sequence:

DISPLAY SET-UP
 MORE SETUP (software ver. VF)
 DIAGNOSTICS
 DISPLAY ALIGNMENT
 B

Check the following signals on the Z-Amp Board.

VIDEO IN, R30 - upper leg, and
 BLANKING, R5 - upper leg.

Compare signals to Figures 6-12 and 6-13 for a 1280, and Figures 6-14 and 6-15 for a 1281.

Are signals okay?

- Yes: Continue.
- No: Check wiring harness for continuity between X8 on Curve Board and X1/X2 on Z-Amp Board.

Refer to Appendix B, Figure B-1.1 or B-1.2 as appropriate.

Replace Curve/Deflection Board harness if bad. If problem is corrected, proceed to Functional Verification, Chapter 5.

If unable to correct problem, replace Curve Board. Proceed to Functional Verification, Chapter 5.

3. With the monitor in display alignment test pattern mode, check the following signals on Z-Amp Board:

CATHODE, R28 - right leg, and
 CONTROL, F1 - left leg.

Compare signals to Figures 6-16 and 6-17 for a 1280, and Figures 6-18 and 6-19 for a 1281.

Are signals acceptable?

- Yes: Replace CRT. Proceed to Functional Verification, Chapter 5.
- No: Replace Z-Amp Board. Proceed to Functional Verification, Chapter 5.

6.7R.vi. Only Dot or Flat Line Appears

CAUTION: If the display shows only a dot in the center of the screen, turn power

OFF immediately to prevent possible damage to the CRT.

1. Check Curve Board output signals VERTICAL (X7-1) and HORIZONTAL (X7-4). Refer to Section 6.8.

Are signals okay?

- Yes: Continue.
- No: Replace Curve Board. Proceed to Functional Verification, Chapter 5.

2. Check Curve/Deflection Boards harness for continuity between X7 of Curve Board and X2 of Deflection Board. Refer to the appropriate monitor wiring diagram in Appendix B, Figure B-1.1 or B-1.2.

Replace wiring harness if bad.

If unable to correct problem, replace Deflection Board.

Proceed to Functional Verification, Chapter 5.

6.7R.vii. Oversized Display

1. Is correct software installed?
 - Yes: Continue.
 - No: Replace software. Proceed to Functional Verification, Chapter 5.
2. Check high voltage and adjust if necessary. Refer to Chapter 7, Section 7.2. If unable to restore proper display, refer to Section 7.3.

6.7R.viii. Poor Alignment

Refer to Chapter 7, Section 7.3 for procedures in Display Adjustment.

6.7R.ix. Blanking Problem

This Section applies if the display is not being blanked properly during retrace, or if the display is being blanked at improper times (during periods other than retrace).

1. Set monitor to display the alignment test pattern. Check BLANKING signal on Z-Amp Board; refer to step 6.7R.v.2.

Is BLANKING signal okay?

- Yes: Replace Z-Amp Board. Proceed to Functional Verification, Chapter 5.
- No: Check wiring harness for continuity between X8 on Curve Board and X1/X2 on Z-Amp Board. Refer to the appropriate monitor wiring diagram in Appendix B, Figure B-1.1 or B1.2.

Replace Curve/Deflection Board harness if bad. If problem is corrected, proceed to Functional Verification, Chapter 5.

If unable to correct problem, replace Curve Board. Proceed to Functional Verification, Chapter 5.

6.7R.x. Glitches in Display

Replace Curve Board. If glitches are still present in display, replace Deflection Board. Proceed to Functional Verification, Chapter 5.

6.7R.xi. Curves Jittering

Refer to Section 6.7R.x.

6.7R.xii. Display Size Fluctuating

This Section applies if display size continually varies.

System SIRECUST 1280/1281 Bedside Monitor - Service Manual

NOTE: It is tolerable for the display size to vary following initial power up, while the high voltage is stabilizing.

1. Check high voltage and adjust if necessary (refer to Chapter 7, Section 7.2).
2. If display size continues to fluctuate replace Z-Amp Board. Proceed to Functional Verification, Chapter 5.

6.7R.xiii Blinking

1. Refer to Section 6.7R.v, Steps 1 - 2.
2. If unable to correct problem, replace Z-Amp Board. Proceed to Functional Verification, Chapter 5.

6.7S. Digital I/O Problem

This Section applies when a problem is observed with the digital I/O signals (ALARM OUT, SYNC OUT, etc.) at ALARM connector X10 on rear panel of monitor.

1. Perform digital I/O functional verification test. Refer to Chapter 5. Does monitor pass test?

- Yes: Problem is external to the monitor.
- No: Replace Curve Board. Proceed to Functional Verification, Chapter 5.

6.8 Curve Board Test

Figures 6-20 and 6-21 depict typical Curve Board outputs for the Deflection and Z-Amp Boards. To view these signals, set the oscilloscope for 2V/div. and 5ms/div. Use the signal at X7-9 for trigger.

NOTE: These signals should be checked prior to replacement of any other display subsection board.

NOTE: To determine pin 1 on each connector, locate the square solder pad on the solder side of the board, or refer to Figure 6-22.

Voltage levels of signals may vary slightly, but should remain within the limits specified in Figure 6-23.

NOTE: The number of pulses present on the BLANKING signal during the raster mode depends on the display. Additional pulses may be present on the the BLANKING and Z signals (depending on the display).

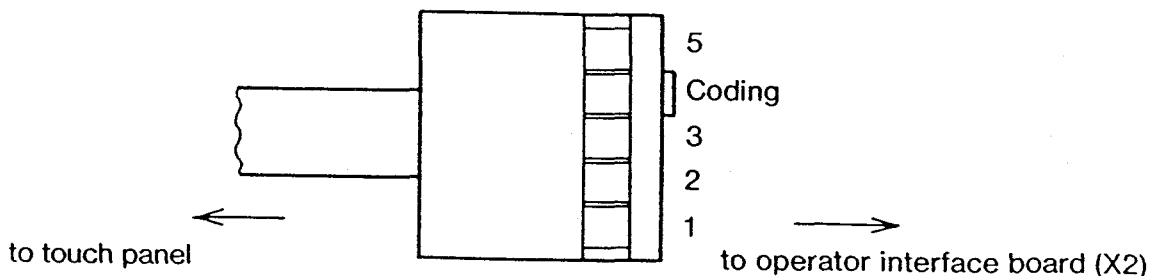

Figure 6-2. TouchScreen Connector

System SIRECUST 1280/1281 Bedside Monitor - Service Manual

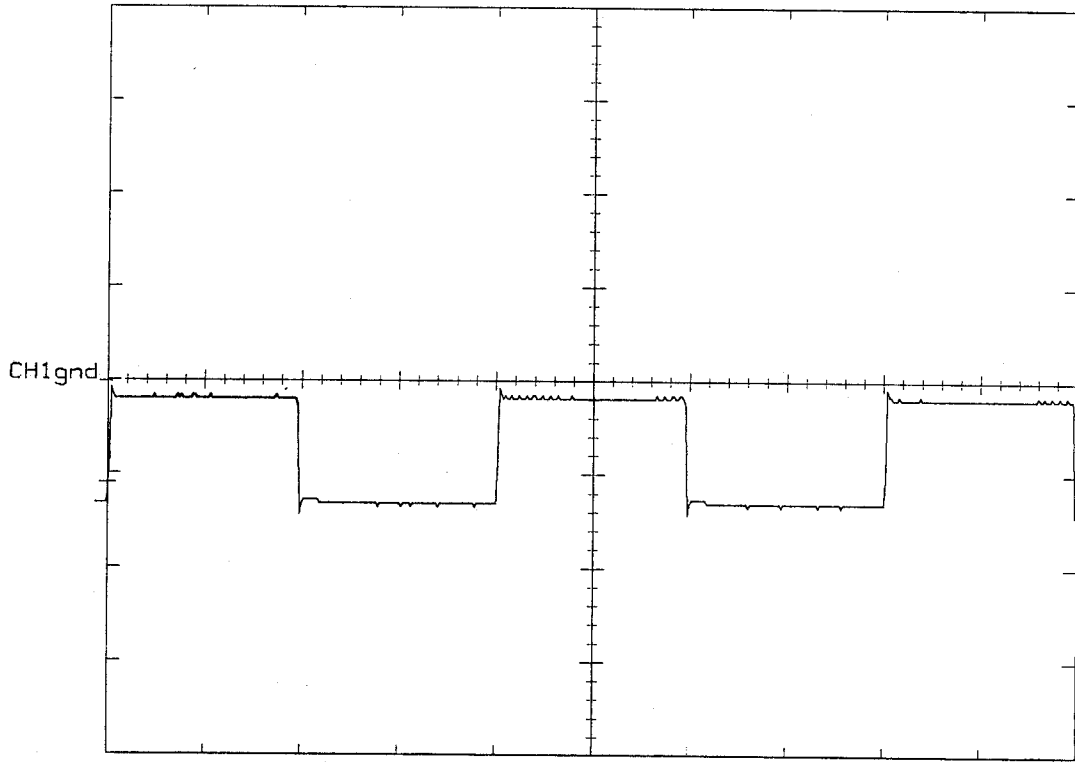

Figure 6-3. Z (After DISPLAY SET-UP Fixed Key is Pressed): 1280 (Curve Board: X8-1) (2V/div., 5ms/div.)

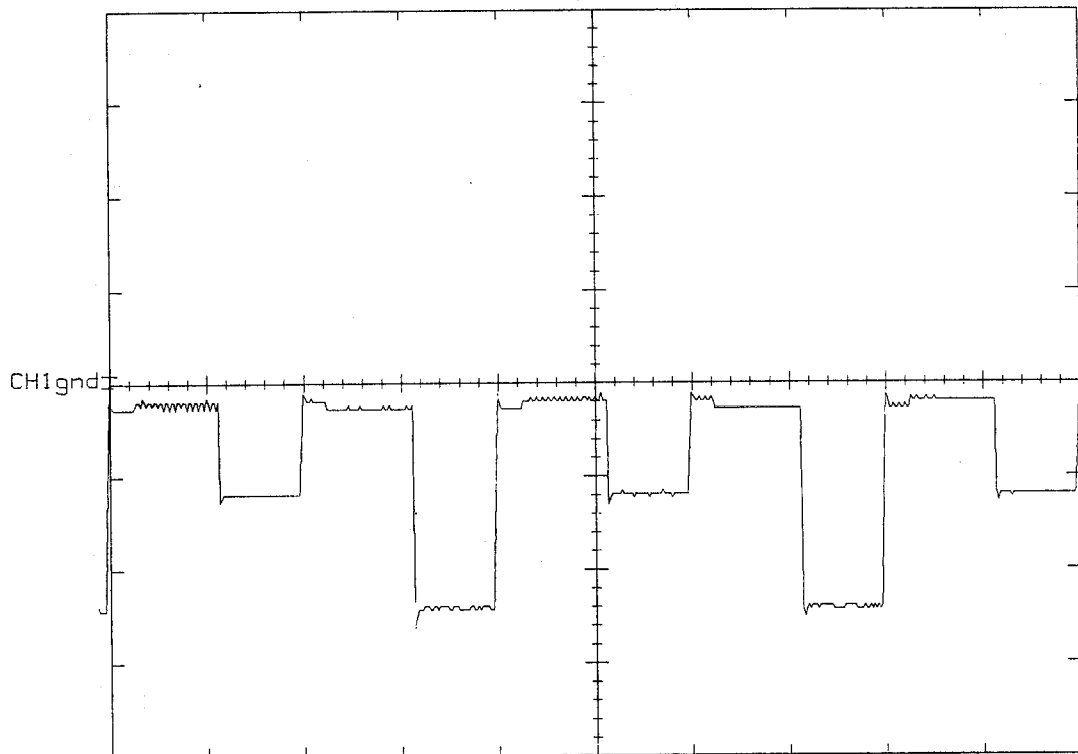

Figure 6-4. Z (After DISPLAY SET-UP Fixed Key is Pressed): 1281 (Curve Board: X8-1) (2V/div., 5ms/div.)

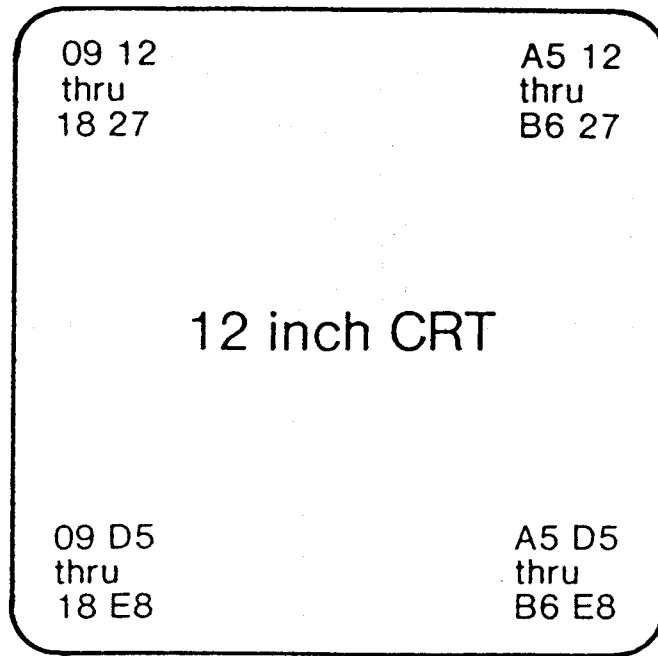

Figure 6-5. TouchScreen Accuracy Test Limits

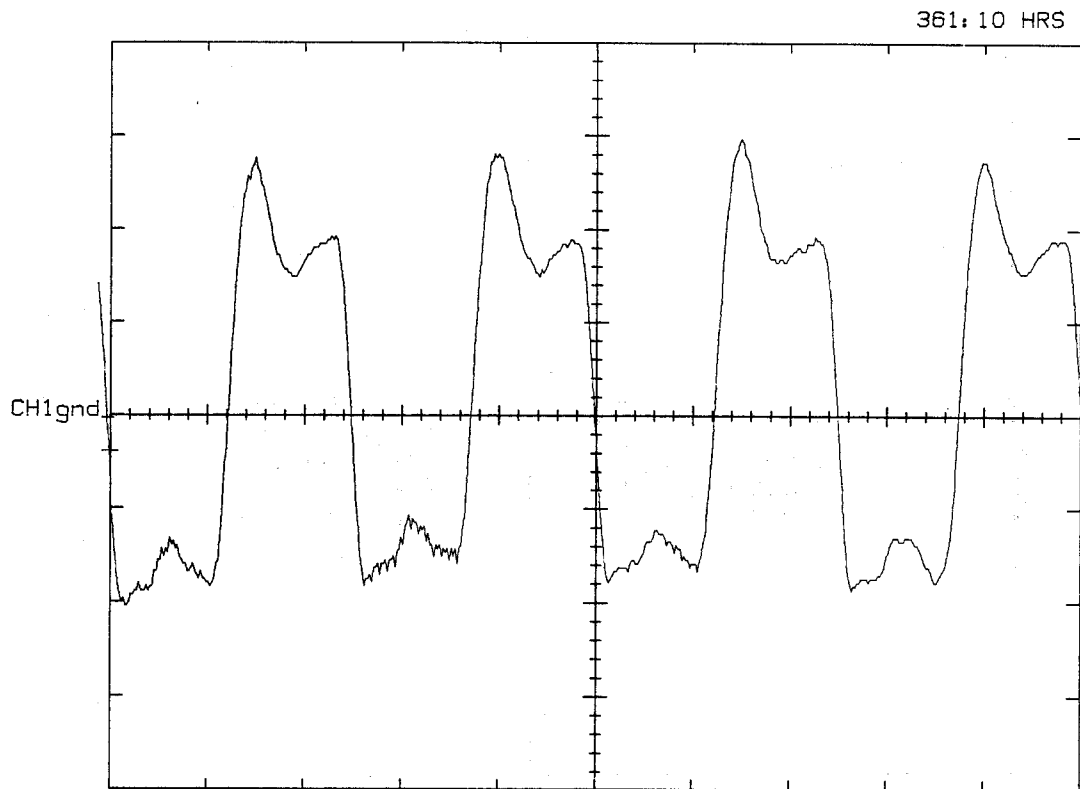

Figure 6-6. BEEPER (Mother Board, X6-2) (1V/div., 1ms/div.)

System SIRECUST 1280/1281 Bedside Monitor - Service Manual

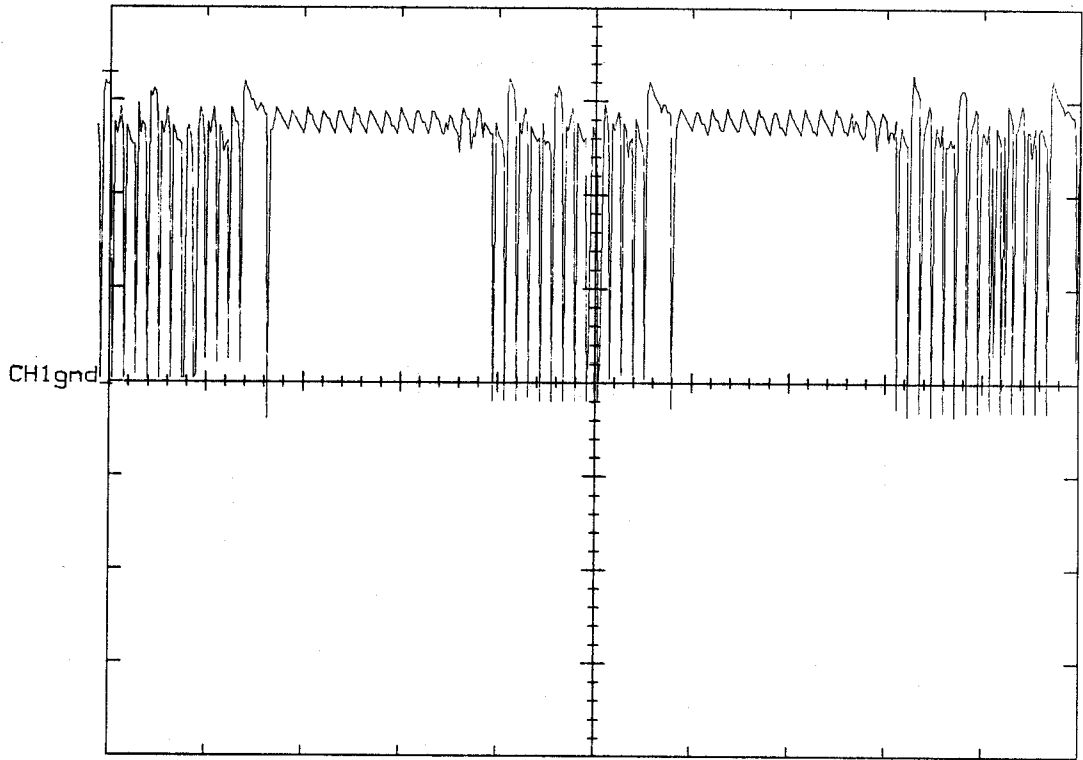

Figure 6-7. CLK Signals for SIREM (Rear Panel Connectors X16/X17: Pins 1→2, 3→4, 5→6, 7→8) (2V/div., 0.1 ms/div.)

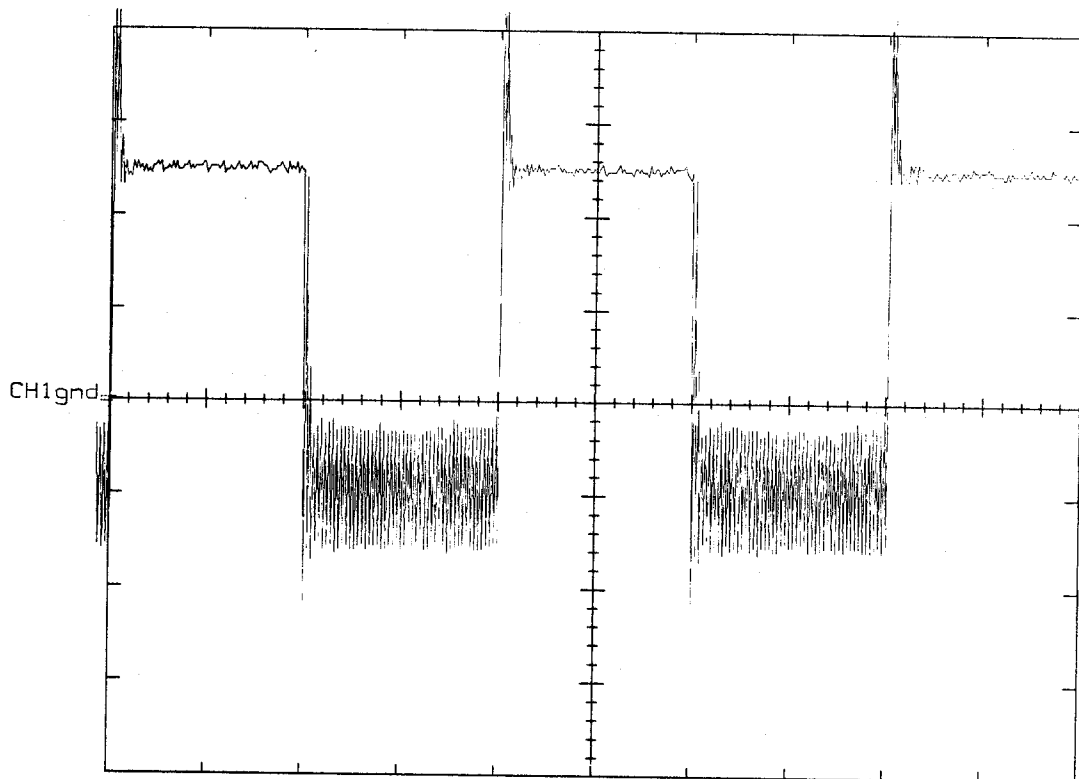

Figure 6-8. 25K (Rear Panel Connectors X16/X17: Pin 17→18) (2V/div., 10μs/div.)

System SIRECUST 1280/1281 Bedside Monitor - Service Manual

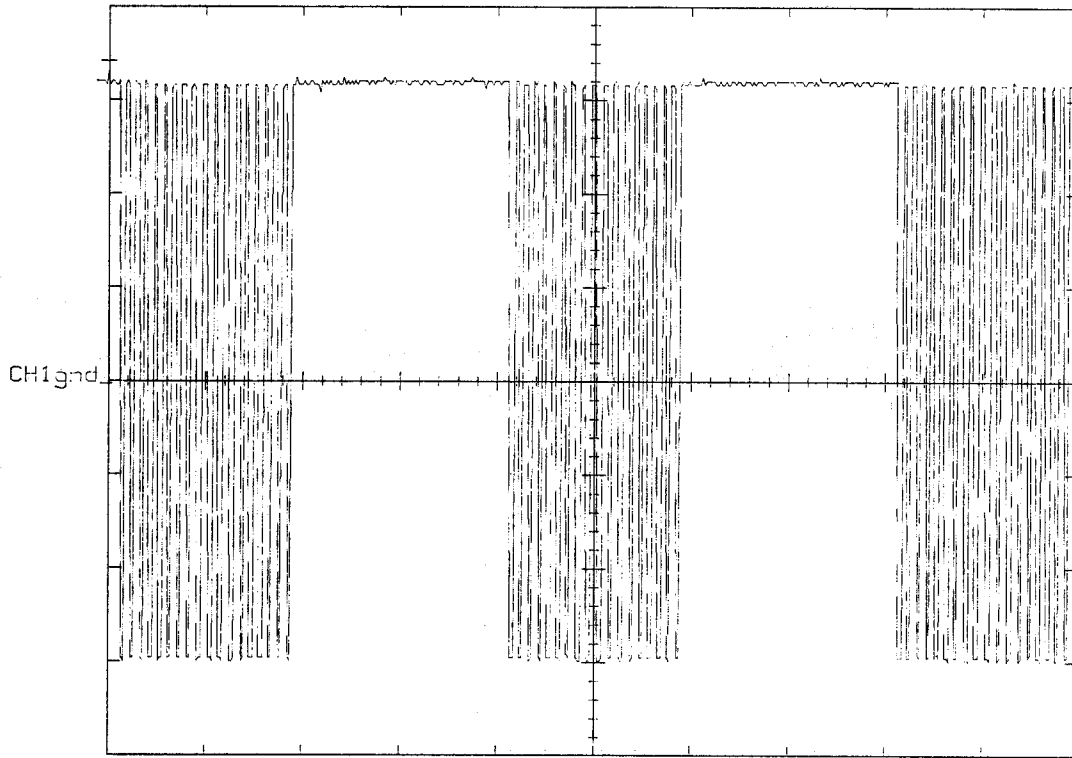

Figure 6-9. SH1, SH2, SH3, SH4 (Operator Interface Board: X2-7, X2-8, X2-9, X2-10) (5V/div., 5ms/div.)

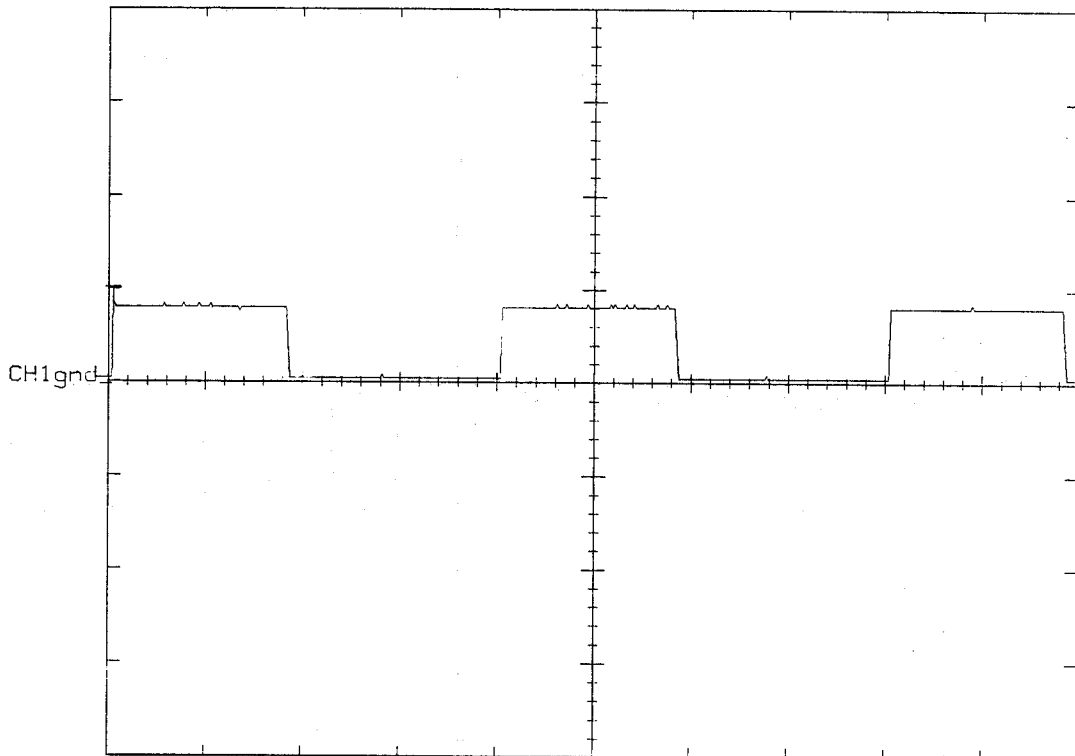

Figure 6-10. LEFTR/G, RIGHTR/G (VME Extender Bd., Curve Bd. Connected: TP2 C-21, C-22) (5V/div., 5ms/div.)

System SIRECUST 1280/1281 Bedside Monitor - Service Manual

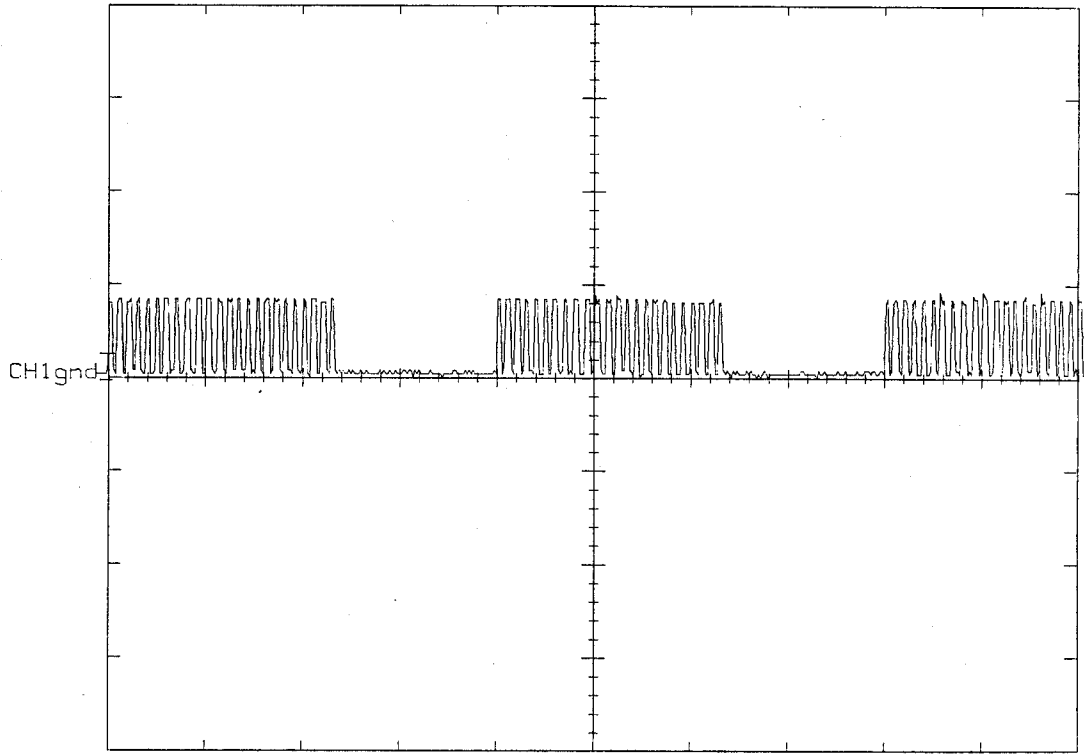

Figure 6-11. SHCLK (VME Extender Bd. With Curve Bd. Connected: TP2 C-23) (5V/div., 5ms/div.)

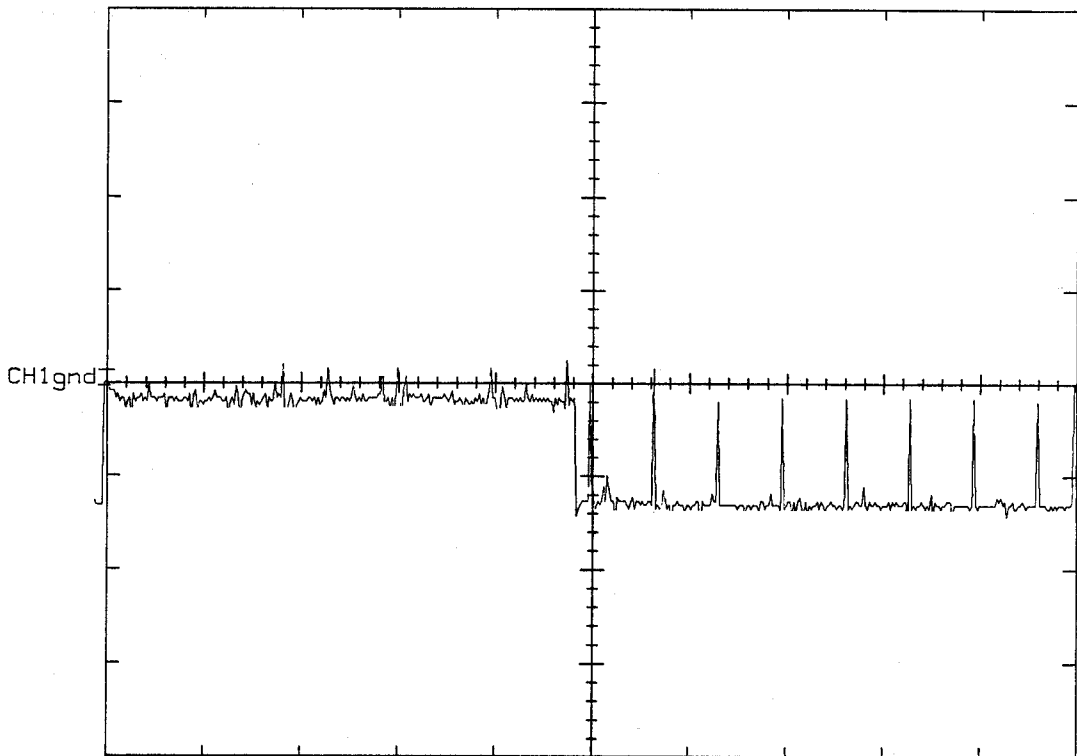

Figure 6-12. VIDEO IN: 1280 (Z-Amp Board: R30 Upper Leg) (2V/div., 2ms/div.)

System SIRECUST 1280/1281 Bedside Monitor - Service Manual

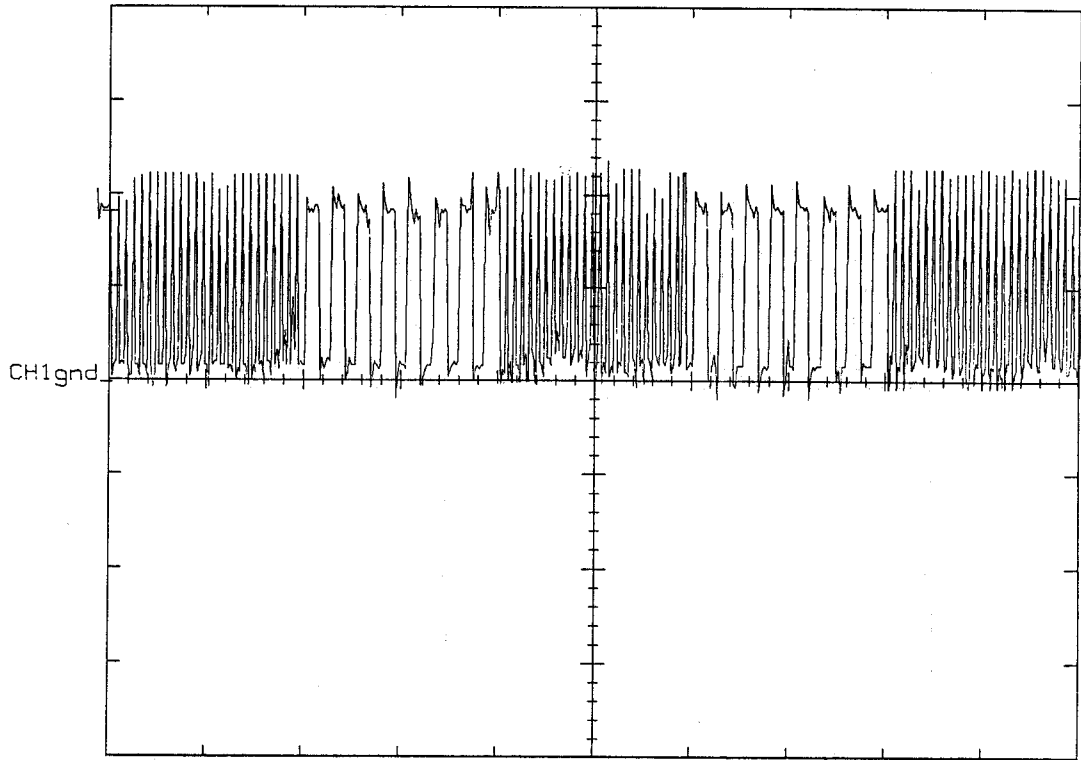

Figure 6-13. BLANKING: 1280 (Z-Amp Board: R5 Upper Leg) (2V/div., 5ms/div.)

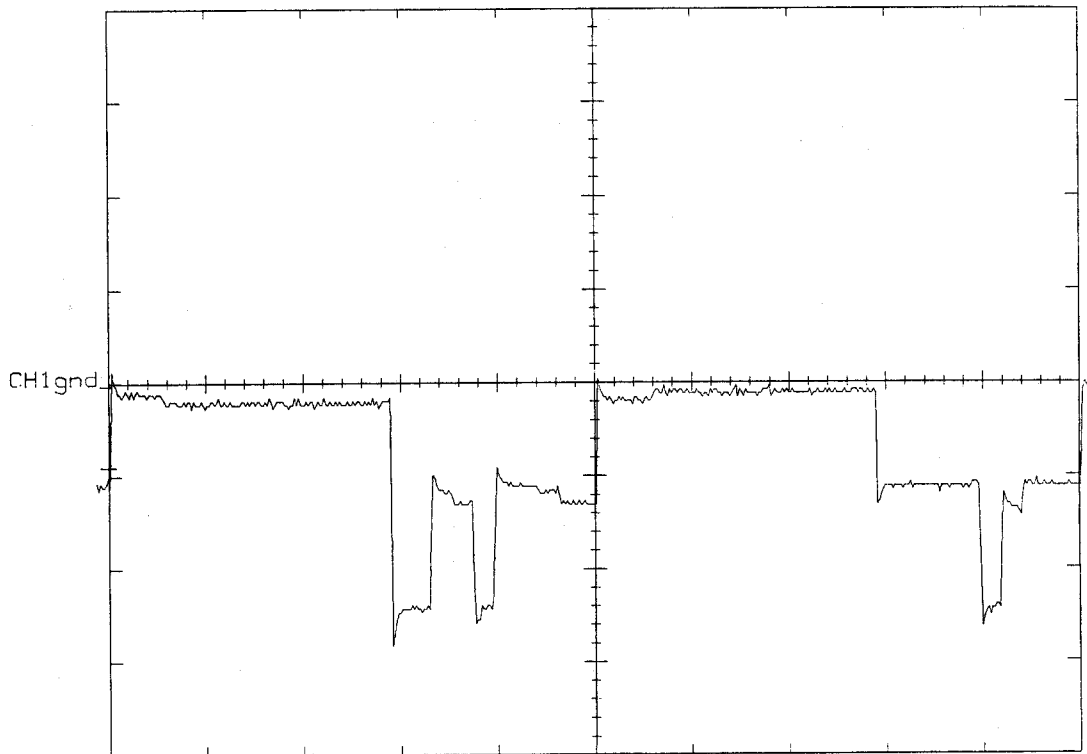

Figure 6-14. VIDEO IN: 1281 (Z-Amp Board: R30 Upper Leg) (2V/div., 2ms/div.)

System SIRECUST 1280/1281 Bedside Monitor - Service Manual

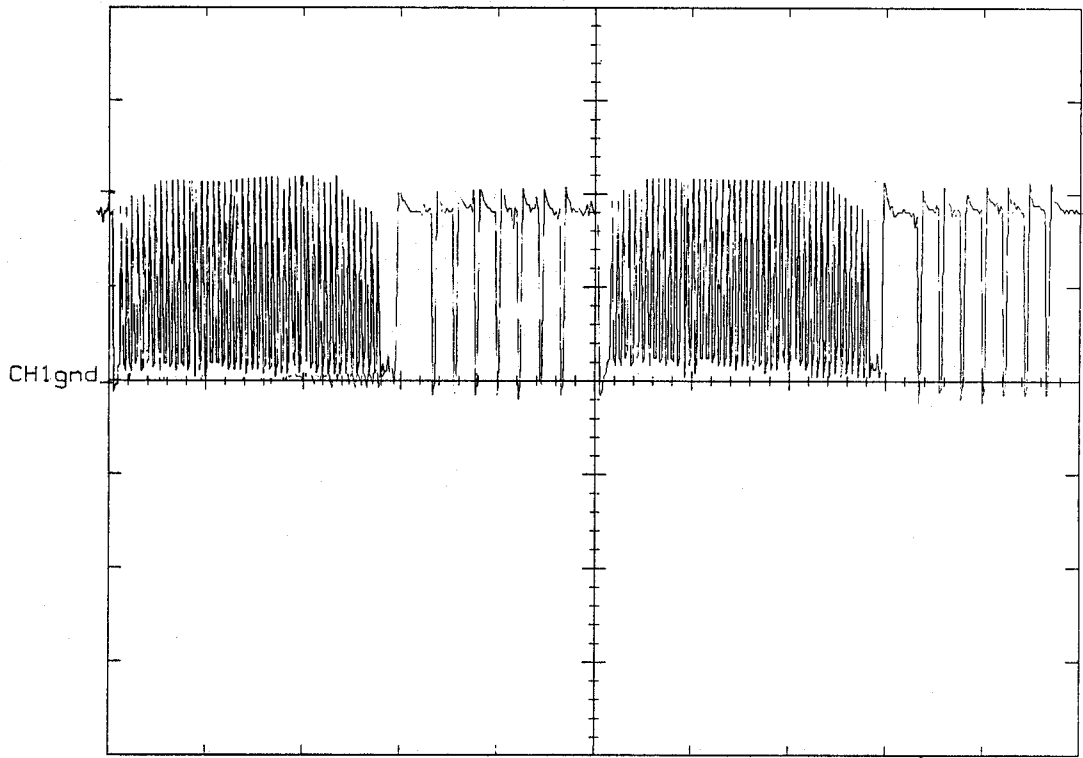

Figure 6-15. *BLANKING: 1281 (Z-Amp Board: R5 Upper Leg) (2V/div., 2ms/div.)*

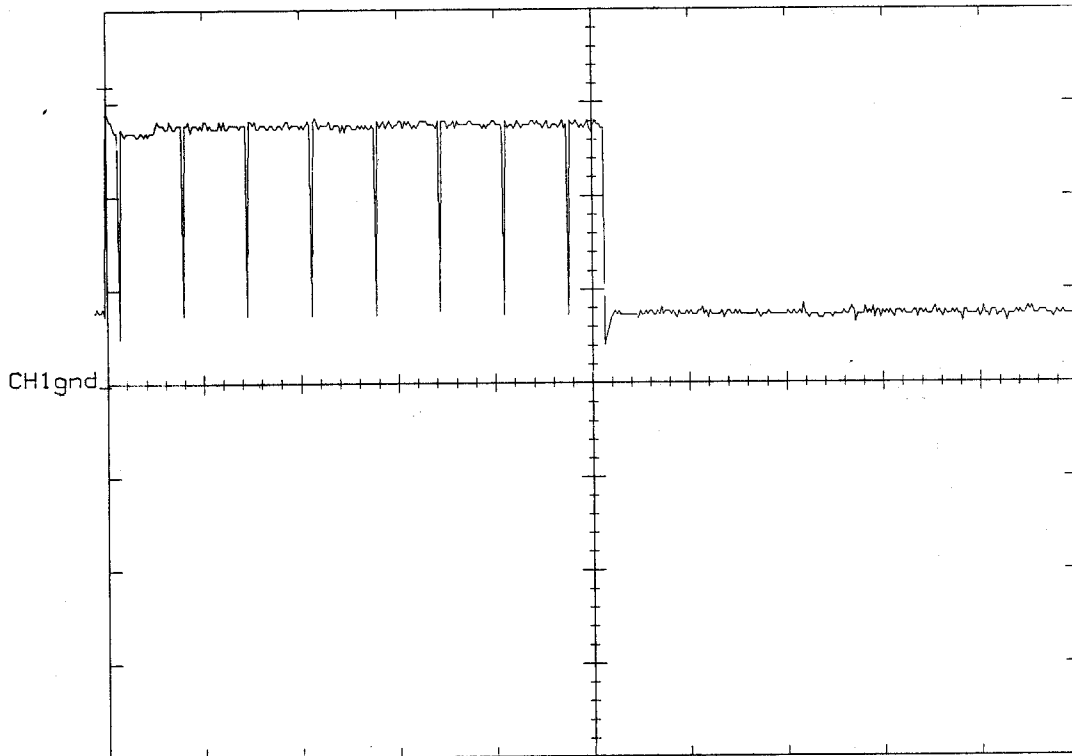

Figure 6-16. *CATHODE: 1280 (Z-Amp Board: R28 Right Leg) (10V/div., 2ms/div.)*

System SIRECUST 1280/1281 Bedside Monitor - Service Manual

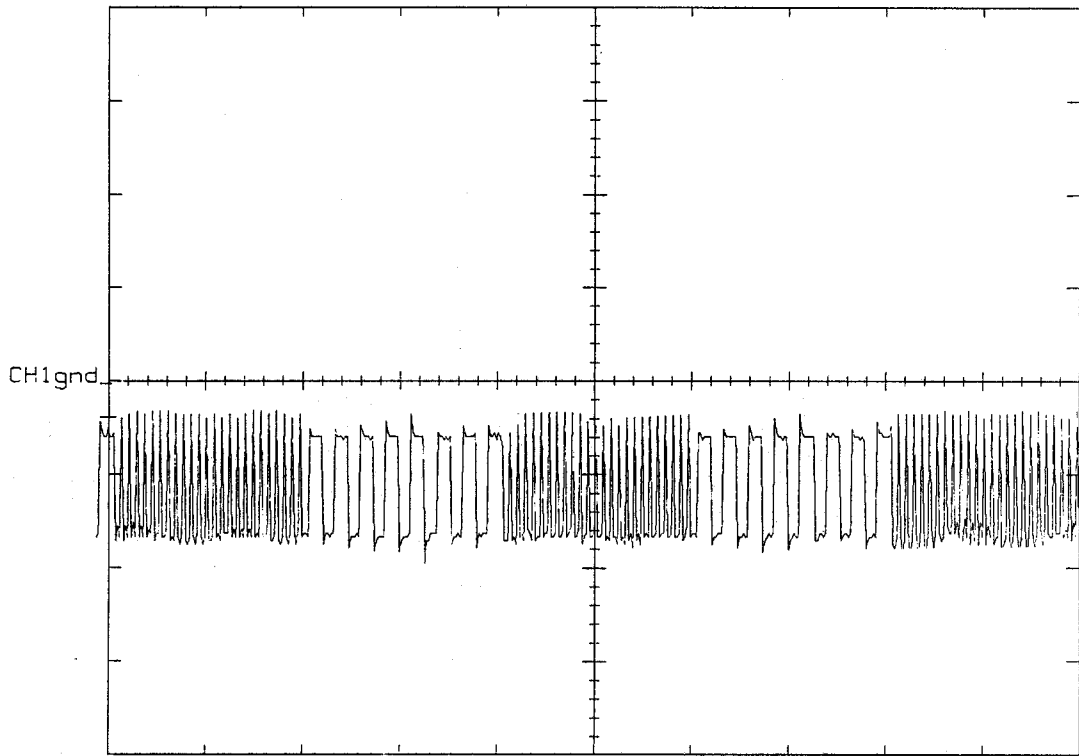

Figure 6-17. CONTROL: 1280 (Z-Amp Board: F1 Left Leg) (50V/div., 5ms/div.)

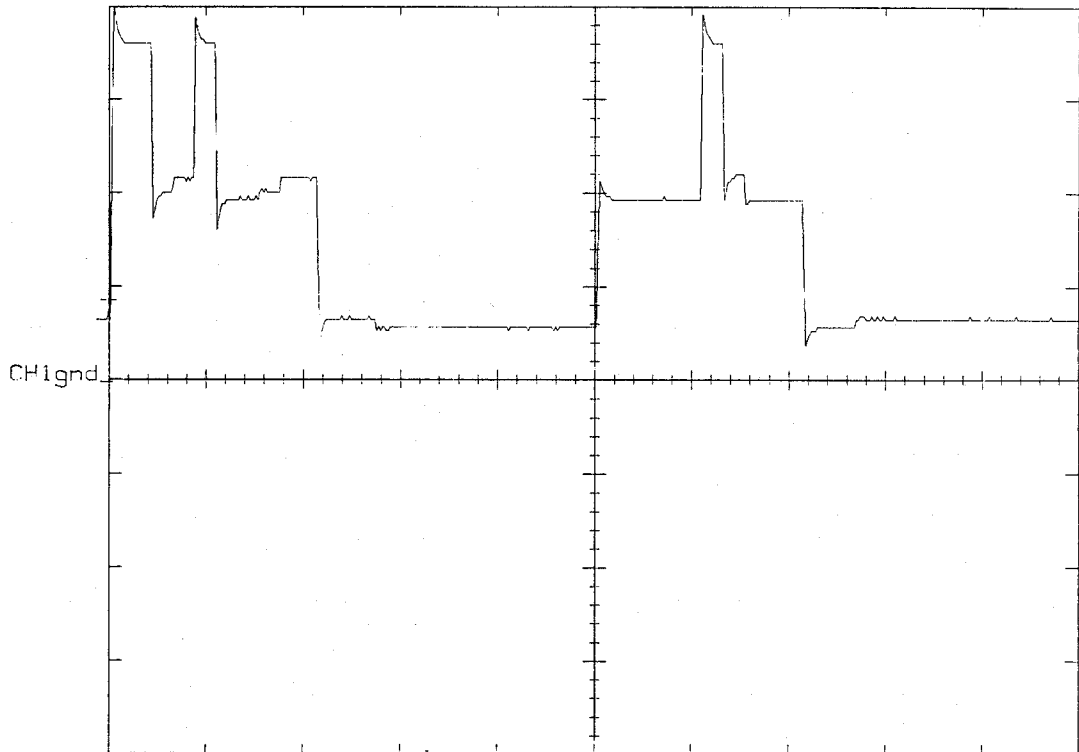

Figure 6-18. CATHODE: 1281 (Z-Amp Board: R28 Right Leg) (20V/div., 2ms/div.)

System SIRECUST 1280/1281 Bedside Monitor - Service Manual

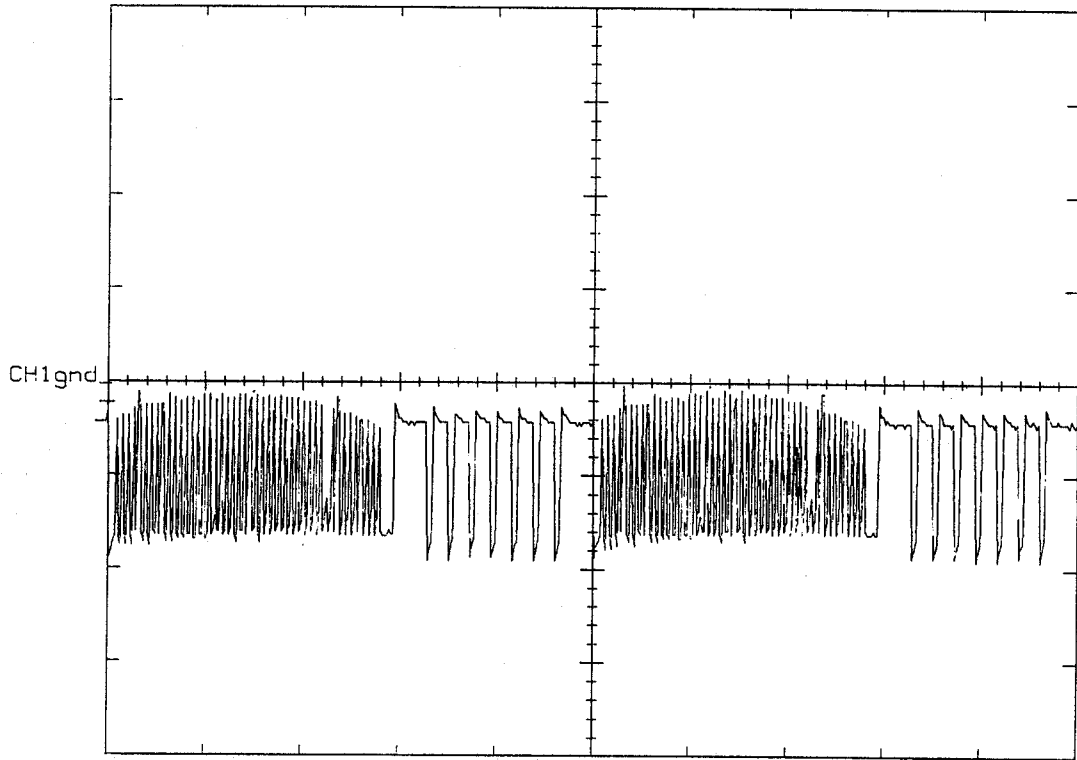

Figure 6-19. CONTROL: 1281 (Z-Amp Board: F1 Left Leg) (50V/div., 2ms/div.)

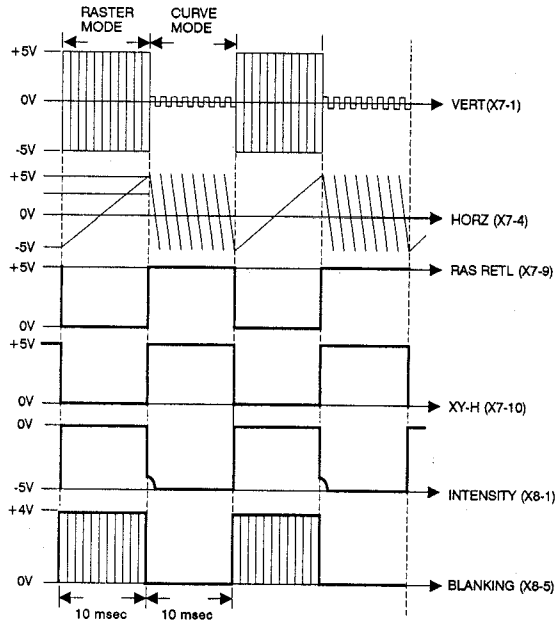

Figure 6-20. Curve Board Signals for 1280

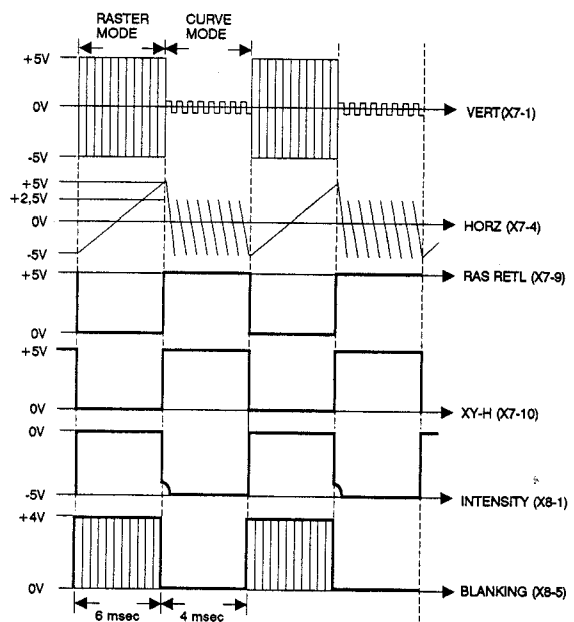

Figure 6-21. Curve Board Signals for 1281

System SIRECUST 1280/1281 Bedside Monitor - Service Manual

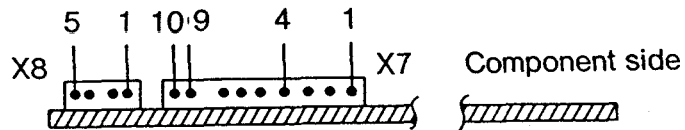

Figure 6-22. Pin Locations on Curve Board Output Connectors

Location	Signal	Range
X7-1	Vertical	$\pm 7V$
X7-4	Horizontal	$\pm 7V$
X7-9	Rasret-L	0 to +5 V
X7-10	XY-H	0 to +5 V (square wave)
X8-1	Intensity	0 to -5 V
X8-5	Blanking	0 to +5 V

Figure 6-23. Curve Board Output Signal Limits

CHAPTER 7

CALIBRATION/ADJUSTMENT

TABLE OF CONTENTS

7.	CALIBRATION/ADJUSTMENT	1
7.1.	Main Power Supply Voltages	1
7.1.1.	+5 V _{DC} Supply	1
7.1.2.	+15 V _{DC} Supply Voltage	2
7.2.	High Voltage	2
7.3.	Display Alignment	2
7.3.1.	Rough-Adjustment of Image Geometry/Raster	5
7.3.2.	Deflection Current (Retrace) Adjustment	5
7.3.3.	Fine-Adjustment of Image Geometry/Raster	6
7.3.4.	Rough-Adjustment of Curves	6
7.3.5.	Fine-Adjustment of Curves	8
7.3.6.	Linearity Check	8
7.3.7.	Curve-Grid Final Alignment	8
7.3.8.	Display Focus Adjustment	8

LIST OF FIGURES

Figure 7-1.	+5 V _{DC} and +15 V _{DC} Voltage Test Points on Display Processor Board	2
Figure 7-2.	SIRECUST 1280 Adjustment Potentiometer Locations - Top View ..	3
Figure 7-3.	SIRECUST 1281 Adjustment Potentiometer Locations - Top View ..	4
Figure 7-4.	Display Alignment Test Pattern	5
Figure 7-5.	Deflection Board Current Shunt Installation	6

LIST OF TABLES

Table 7-1.	Recommended Tools and Test Equipment, Calibration/Adjustment ...	1
Table 7-2.	Display Subsection Boards	2
Table 7-3.	Potentiometer Function and Location	7

7. CALIBRATION/ADJUSTMENT

This chapter details calibration procedures to be performed anytime a printed circuit board in the display subsection is replaced, or if the monitor fails functional verification testing. The procedures are used to test the display subsection for proper operation, align the display, and calibrate the monitor so that it uses minimum power.

Calibration procedures require access to potentiometers located on the printed circuit boards within the monitor.

- Open and close the monitor only in accordance with procedures outlined in Chapter 4, Sections 4.1 and 4.2.
- Perform the appropriate functional verification procedures outlined in Chapter 5 before returning the monitor to normal bedside service.

Boards comprising the display subsection of the monitor are identified in Table 7-2.

Refer to Table 7-3, and Figure 7-2 or Figure 7-3 for identification and location of specific potentiometers referenced in the procedures outlined in this chapter.

7.1. Main Power Supply Voltages

NOTE: Use monitor chassis as ground. Adjust power supply voltages with the monitor configured for a normal operational load, i.e. SIREMS equipped with cartridges and all Boards installed.

7.1.1. +5 V_{DC} Supply Voltage

1. Connect a digital voltmeter (DVM) to the right leg of R17 on the Display Processor Board. Refer to Figure 7-1.
2. Set R3 of the Power Supply Board to $+5 \pm 0.05 V_{DC}$.
3. Secure R3 with Torque-Seal[®] or an equivalent substance to prevent any rotation and change in the setting.

Table 7-1. Recommended Tools and Test Equipment, Calibration/Adjustment

<u>TOOL/EQUIPMENT</u>	<u>DESCRIPTION</u>
Current Shunt, Mono (for 1280)	SIEMENS Art. No. 96 60 606 EE999
Current Shunt, Color (for 1281)	SIEMENS Art. No. 96 60 614 EE999
12 inch Video Alignment Grid	SIEMENS Art. No. 84 28 450 RE999
VME Extender Board	SIEMENS Art. No. 87 91 568 E2524
POLYMED/LIM Simulator or Waveform Simulator	SIEMENS Art. No. 45 28 345 EH436 Dynatech-Nevada, Model 215A (or equivalent)
Digital Multi-Meter (DMM), 4½ digit	Fluke, Model 8050A (or equivalent)
High Voltage Probe (for DMM), 1000:1	Fluke 80K-40 (or equivalent)
Insulated Adjustment Wand, long handle w/ 1.8mm - 2.5mm wide blade	
Bolt, M4 X 35	

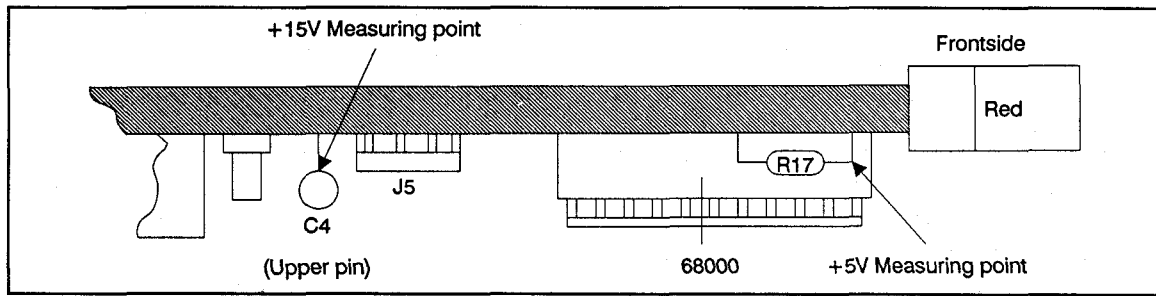

Figure 7-1. +5 V_{dc} and +15 V_{dc} Voltage Test Points on Display Processor Board

7.1.2. +15 V_{dc} Supply Voltage

1. Connect the digital voltmeter (DVM) to the upper leg of C4 on the Display Processor Board. Refer to Figure 7-1.
2. Adjust R14 on the Power Supply Board to +15.5 ±0.1 V_{dc}.
3. Secure R14 with Torque-Seal® or an equivalent substance to prevent any change in the resistance setting of the potentiometer.

3. Using the probe, connect the DVM to the anode of the CRT.
4. Verify that the connection on the CRT anode is secure.
5. Switch monitor power ON.
6. After one minute, adjust R63 on the Z-Amp Board to produce a high-voltage reading of +15 KV ±100 V.
7. Switch monitor power OFF and disconnect the probe from the monitor.

7.2. High Voltage

WARNING: The high-voltage circuitry retains lethal voltage for approximately 30 seconds after the monitor has been switched OFF.

1. Switch the monitor power OFF.
2. Connect the ground lead of a high-voltage probe to the monitor chassis.

7.3. Display Alignment

NOTE: Switch monitor power ON and allow monitor to remain ON for one hour before performing this procedure.

Specific potentiometers referenced in the following procedures may not be used on all monitors. Refer to Table 7-3 for a cross-reference of potentiometers used on particular boards.

Table 7-2. Display Subsection Boards

	<u>CURVE BOARD</u>	<u>DEFLECTION BOARD</u>	<u>Z-AMP BOARD</u>	<u>POWER SUPPLY BOARD</u>
1281	A270 87 91 667 E2500	A310 87 91 873 E2500	A261 87 91 865 E2500	A280 87 91 675 E2500
1280	A130 87 91 402 E2500	A160 87 91 436 E2500	A181 87 91 857 E2500	A140 87 91 410 E2500

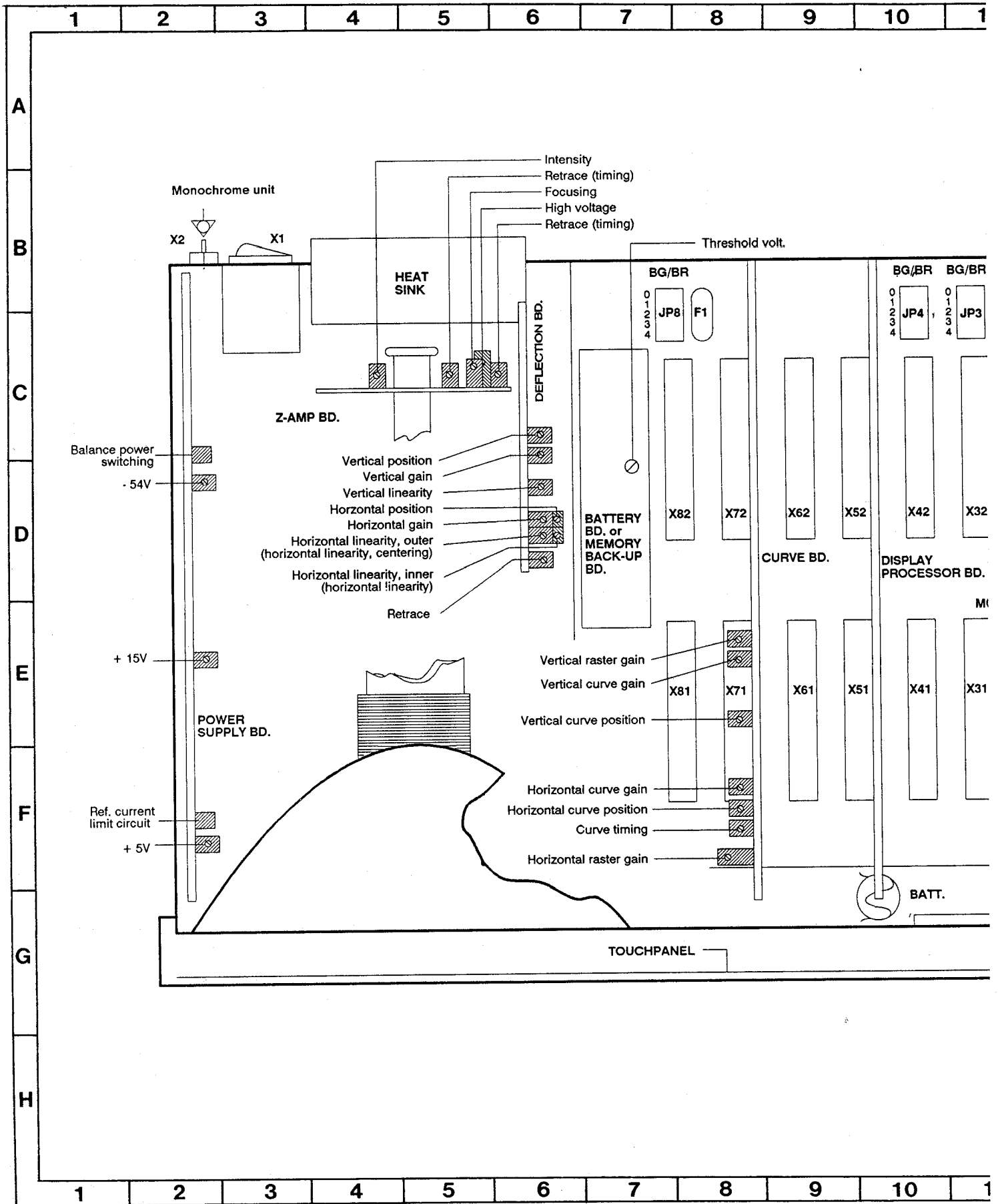
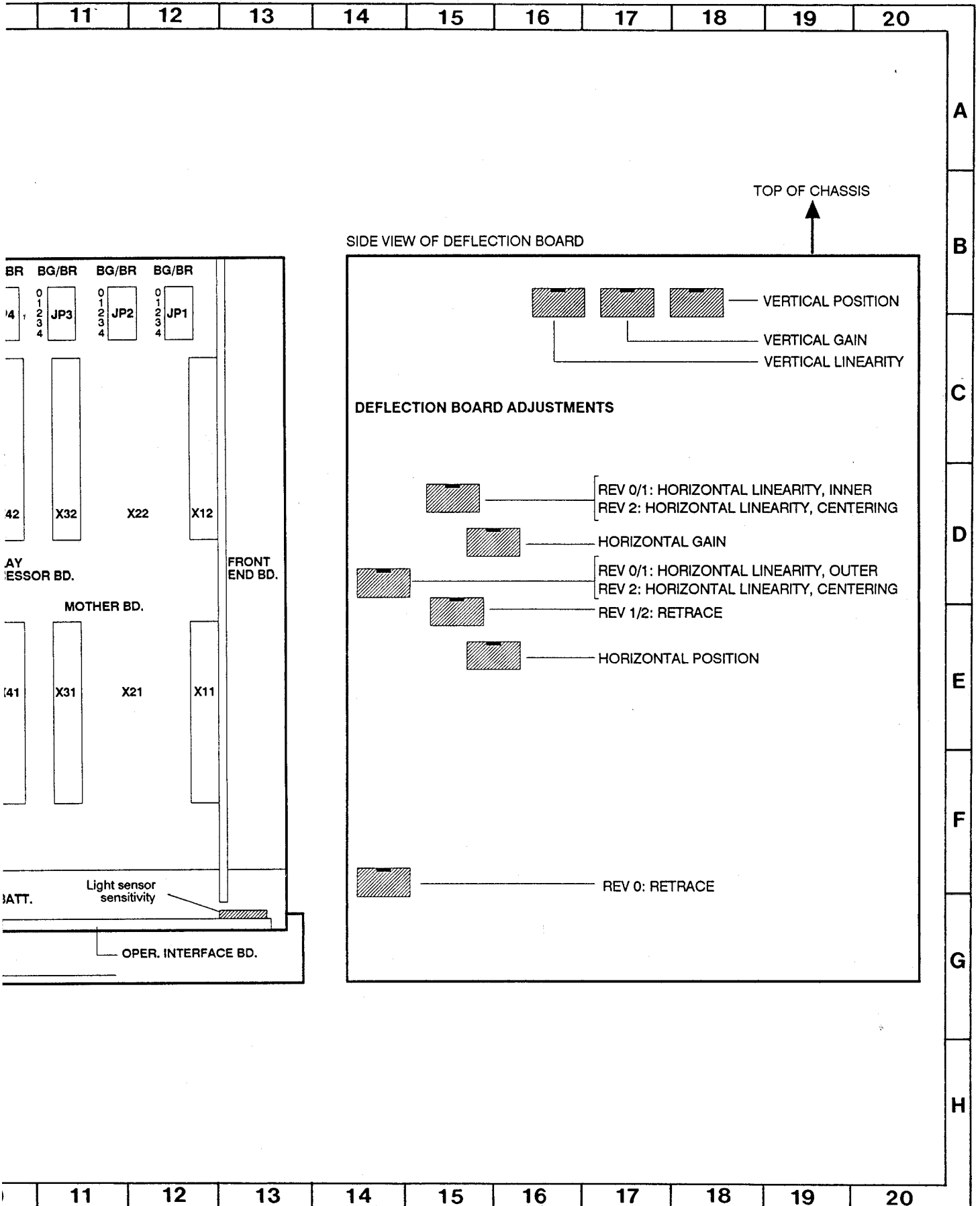

Figure 7-2. SIRECUST 1280 Adjustment Potentiometer Locations

System SIRECUST 1280/1281 Bedside Monitor - Service Manual



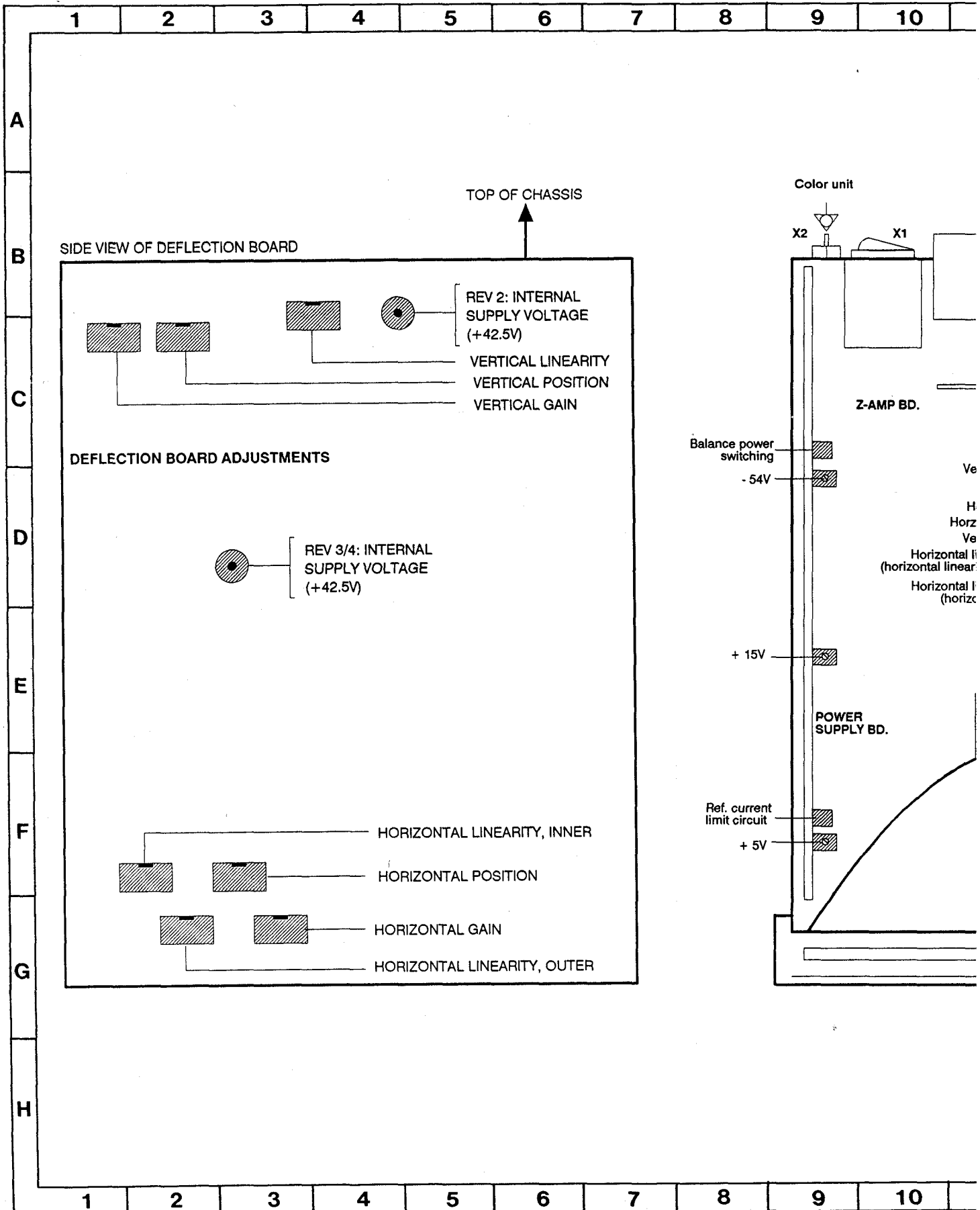
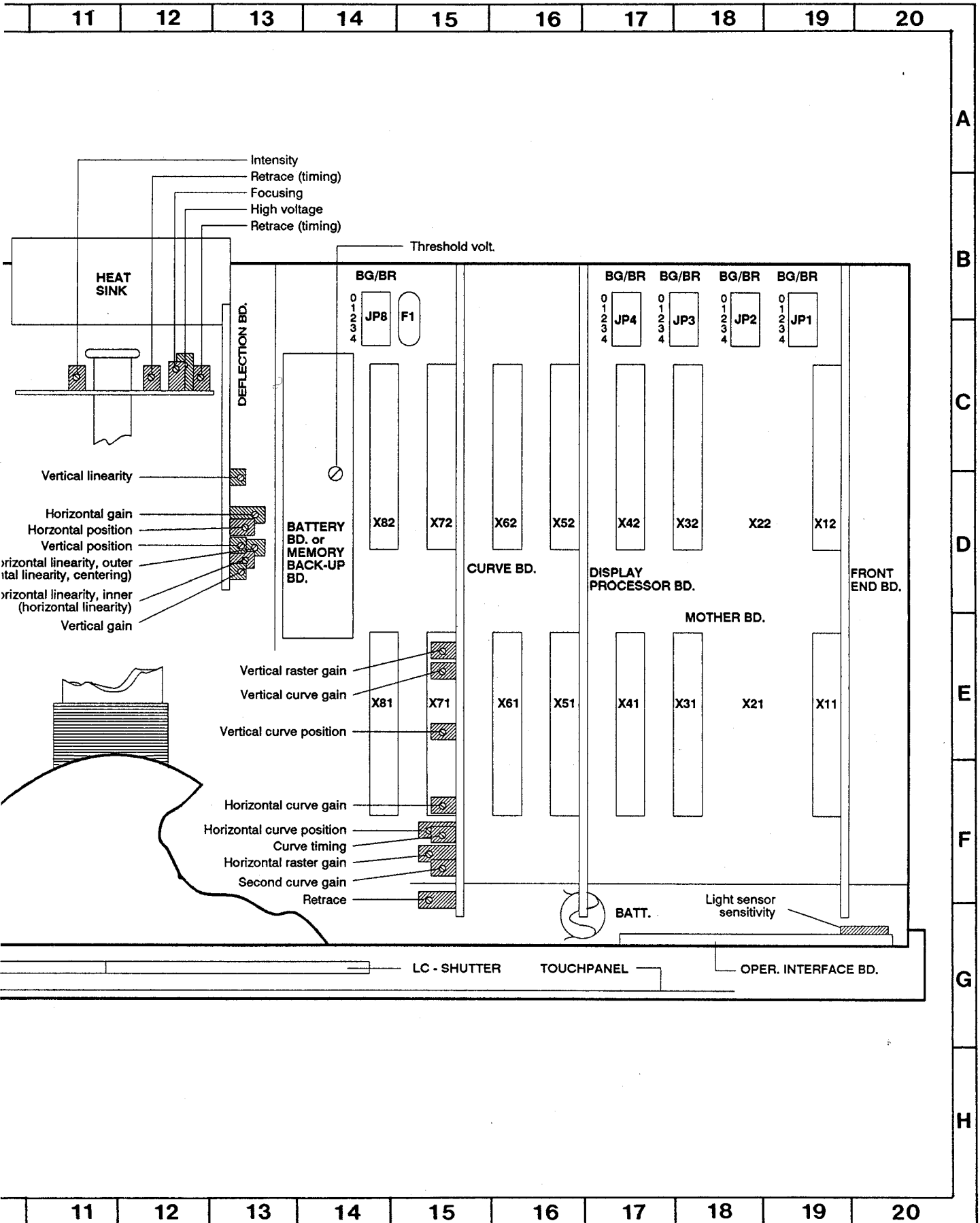

Figure 7-3. SIRECUST 1281 Adjustment Potentiometer Locations.



Press the following KEY sequence to set the monitor for display alignment test pattern mode:

DISPLAY SET-UP
 MORE SETUP (software ver. VF)
 DIAGNOSTICS
 DISPLAY ALIGNMENT
 B

The test pattern appears as in Figure 7-4.

7.3.1. Rough-Adjustment of Image Geometry/Raster

1. Place the video alignment grid in position on the front panel.
2. Set the brightness potentiometer, R3 on the Z-Amp Board, so that the displayed data is visible.
3. Set the following potentiometers on the Deflection Board so that the CRT display grid aligns with the video alignment grid.
 - Horizontal position
 - Horizontal gain
 - Vertical position
 - Vertical gain

7.3.2. Deflection Current (Retrace) Adjustment

Adjust the deflection current if the Curve Board or the Deflection Board is replaced.

1. Unplug connector X3 from the Deflection Board.
2. Plug the male connector of the current shunt into X3 on the wiring harness, and seat the female connector onto X3 on the Deflection Board. Refer to Figure 7-5.
3. Connect the current shunt to the DVM as illustrated in Figure 7-5, observing proper polarity.
4. Adjust the Retrace potentiometer on the Curve Board (1281s) or on

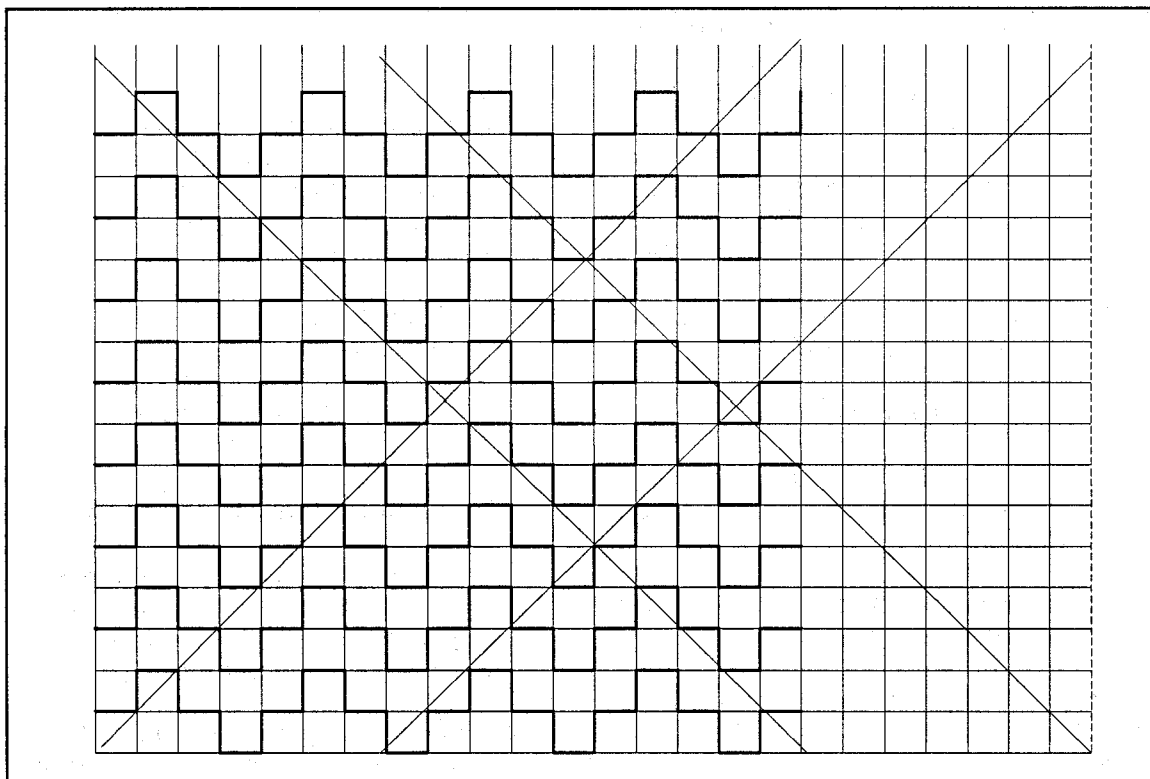

Figure 7-4. Display Alignment Test Pattern

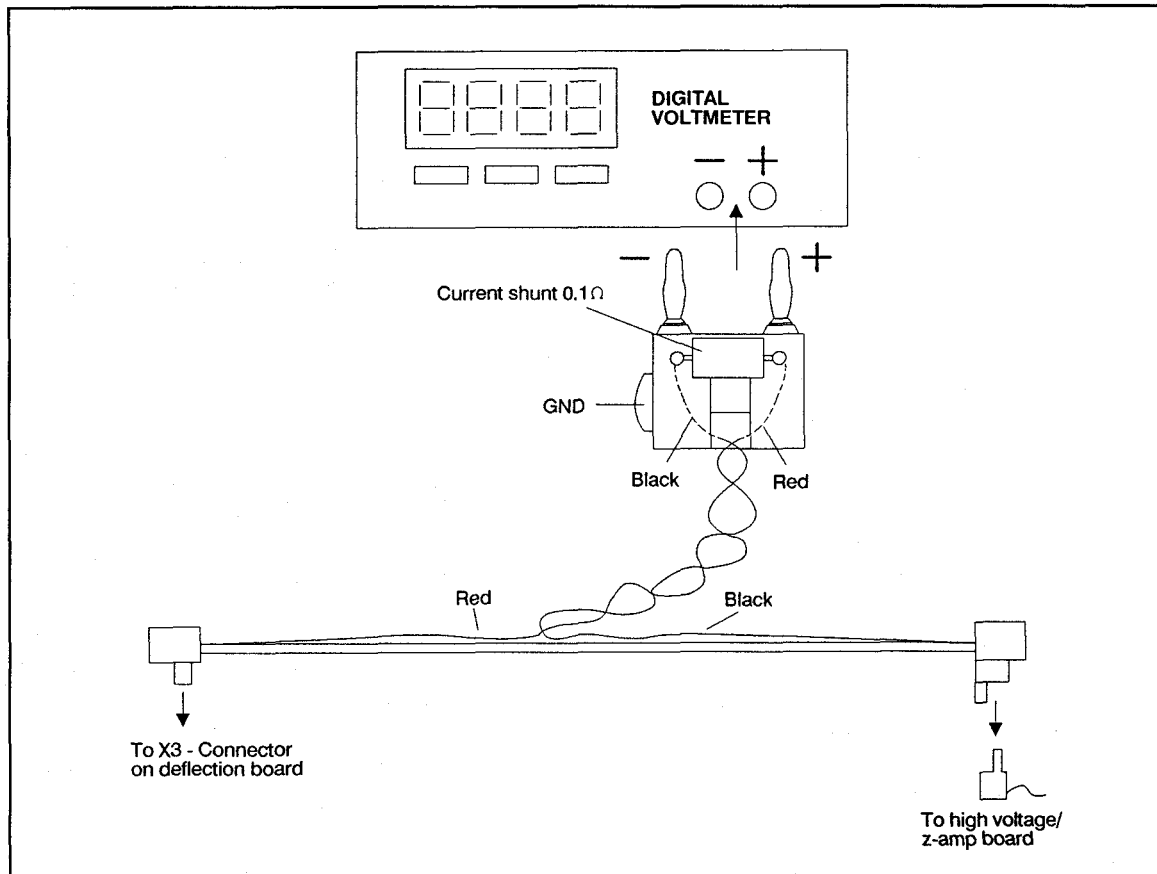

Figure 7-5. Deflection Board Current Shunt Installation

the Deflection Board (1280s) for a DVM reading of -4 mV.

5. Readjust the Retrace potentiometer until the bottom edge of the grid pattern is linear and stable.
6. Check that the DVM voltage = $-4 \text{ mV} < V_{\text{DVM}} < +20 \text{ mV}$.
7. Switch the monitor OFF.
8. Remove the test circuitry, and reconnect X3 to the Deflection Board.

7.3.3. Fine-Adjustment of Image Geometry/Raster

Use the following potentiometers on the Deflection Board to fine-adjust the image geometry.

NOTE: Because the settings are interactive, readjust the potentiometers until the required pattern is displayed on the CRT. Calibration tolerance is ± 1 mm, and the diagonals are straight lines when the monitor is properly adjusted.

- Vertical linearity
- Horizontal linearity
- Horizontal linearity, centering
- Horizontal linearity, outer
- Horizontal linearity, inner

7.3.4. Rough-Adjustment of Curves

NOTE: Vertical and horizontal raster gains are set in the factory. Do NOT attempt to readjust the settings. Curve adjustment does not affect raster gain settings.

Adjust the following potentiometers on the Curve Board so that the square wave pat-

System SIRECUST 1280/1281 Bedside Monitor - Service Manual

Table 7-3. Potentiometer Function and Location

FUNCTION	POTENTIOMETER DESIGNATION								Adjustable by Service Personnel			
	1280 REV.				1281 REV.				YES	NO		
Power Supply Board	<u>0</u>	<u>1</u>	<u>3</u>	<u>0</u>	<u>1</u>	<u>2</u>	<u>3</u>					
+ 5 VDC	R3	R3	R3	R3	R3	R3	R3			*		
+ 15 VDC	R14	R14	R14	R14	R14	R14	R14			*		
-- 55 VDC	---	---	R38	---	---	---	---			*		
-- 80 VDC	---	---	---	R212	R212	R212	R38			*		
Reference current limit circuit	---	---	R71	R225	R225	E225	R71			*		
Comparator bias	---	R103	R103	---	---	R103	R103			*		
Curve Board	1280 REV.				1281 REV.				Adjustable by Service Personnel			
	<u>0</u>	<u>1</u>	<u>2</u>	<u>3</u>	<u>4</u>	<u>0</u>	<u>1</u>	<u>2</u>	<u>3</u>	<u>4</u>	YES	NO
Vertical raster gain	R1	R1	R1	R1	R1	R1	R1	R1	R1	R1	*	*
Vertical curve gain	R23	R23	R23	R23	R23	R23	R23	R23	R23	R23	*	*
Vertical curve position	R26	R26	R26	R26	R26	R26	R26	R26	R26	R26	*	*
Horizontal raster gain	R39	R39	R39	R39	R39	R39	R39	R39	R39	R39		*
Horizontal curve gain	R34	R34	R34	R34	R34	R34	R34	R34	R34	R34	*	*
Horizontal curve position	R38	R38	R38	R38	R38	R38	R38	R38	R38	R38	*	*
Curve timing (lower 4 curves gain)	---	R70	---	---	---	R104	R70	R70	R70	R70	*	*
Retrace	---	---	---	---	---	R105	R65	R65	R65	R65	*	*
2nd curve gain	---	---	---	---	---	---	---	---	R78	R78	*	*
H/V Deflection Board	1280 REV.				1281 REV.				Adjustable by Service Personnel			
	<u>0</u>	<u>1</u>	<u>2</u>	<u>3</u>	<u>4</u>	<u>0</u>	<u>1</u>	<u>2</u>	<u>3</u>	<u>4</u>	YES	NO
Vertical linearity	R15	R2	R2			R6	R6	R6	R13	R13	*	*
Vertical gain	R41	R7	R7			R12	R12	R12	R1	R1	*	*
Vertical position	R7	R13	R13			R11	R11	R11	R4	R4	*	*
Horizontal linearity	---	---	R31								*	*
Horizontal linearity, centering	---	---	R53								*	*
Horizontal linearity, outer	R10	R53	---			R51	R51	R51	R68	R68	*	*
Horizontal linearity, inner	R9	R31	---			R52	R52	R52	R66	R66	*	*
Horizontal gain	R22	R34	R34			R57	R57	R57	R71	R71	*	*
Horizontal position	R1	R72	R72			R76	R76	R76	R67	R67	*	*
Retrace	R133	R90	R90			---	---	---	---	---	*	*
Internal supply voltage (+42.5V)	---	---	---			---	---	R201	R37	R37	*	*
HV/Z AMP Board	1280 REV.		1281 REV.		Adjustable by Service Personnel							
	<u>0</u>	<u>1</u>	<u>0</u>	<u>1</u>	YES	NO						
Retrace timing	R1	R1	R1	R1	*	*						
Retrace timing	R2	R2	R2	R2		*						
High voltage	R63	R63	R63	R63	*	*						
Focusing	R40	R40	R40	R40	*	*						
Intensity	R3	R3	R3	R3	*	*						
Operator Interface Board	1280 REV.		1281 REV.		Adjustable by Service Personnel							
	<u>1</u>	<u>3</u>	<u>1</u>	<u>2</u>	<u>3</u>	YES	NO					
Light sensor sensitivity	R2	R2	R2	R2	R2	*	*					
Battery Backup Board	1280 REV.		1281 REV.		Adjustable by Service Personnel							
	<u>1</u>		<u>1</u>		YES	NO						
Threshold voltage for battery board	R13		R13		*	*						
Line Driver Board	1280 REV.		1281 REV.		Adjustable by Service Personnel							
	<u>1</u>		<u>1</u>		YES	NO						
Curve/Grid alignment (for 120S/121S screen)	R10 (all REV.s.)		R10 (all REV.s.)		*	*						

tern on the CRT display aligns with the video alignment grid.

- Vertical curve gain
- Vertical curve position
- Horizontal curve gain
- Horizontal curve position

7.3.5. Fine-Adjustment of Curves

Adjust the Curve Timing and Second Curve Gain potentiometers on the Curve Board so that the square wave pattern on the CRT display aligns with the video alignment grid.

7.3.6. Linearity Check

1. Remove the video alignment grid from the front panel.
2. Press the STOP fixed-key twice so that the square wave signals move across the CRT display.
3. Verify that the linearity of the signals is maintained across the width of the CRT display.

NOTE: If linearity is NOT maintained, repeat the fine-adjustment procedures outlined in Section 7.3.3.

7.3.7. Curve-Grid Final Alignment

Check curve-grid alignment using two pressure inputs provided by a known good LIM and a patient simulator.

- a. Exit display alignment test pattern mode by either turning the monitor power OFF or pressing the B fixed key repeatedly until diagnostic menu appears. Press MAIN SCREEN fixed-key.

NOTE: Turning power OFF causes loss of patient data.

- b. Place the LIM in the top two cartridge slots of the SIREM.

- c. Connect a patient simulator to the two pressure inputs of the LIM, and set the pressure gain controls of the simulator to 0 mm/Hg.
- d. Attach the SIREM to the SIREM 1 input (X16) on the rear panel.

NOTE: Turn monitor power OFF whenever connecting/disconnecting SIREM.

- e. Turn monitor power ON.
- f. Configure the monitor to exhibit two non-overlapping pressure flatlines (refer to the Operating Instructions for the installed software).
- g. Zero each pressure flatline using the pressure ZERO parameter keys. See Operating Instructions.
- h. Adjust the vertical curve gain and vertical curve position potentiometers on the Curve board to align the curves with their assigned zero grids to ± 0.5 mm.

NOTE: Repeat procedures outlined in Sections 7.3.4, 7.3.5, and 7.3.7 as necessary to attain proper alignment of both the display alignment test pattern screen and the pressure flatlines.

7.3.8. Display Focus Adjustment

1. Set the background brightness so that the CRT display can be viewed comfortably in the ambient light, using the intensity potentiometer on the Z-Amp Board.
2. Press the DISPLAY SET-UP fixed-key to access the display setup menu.
3. Adjust the focusing potentiometer on the Z-Amp Board for maximum definition of the raster information. Verify that the letters in the word DIAGNOSTICS are clear.

APPENDIX A

REPLACEMENT PARTS LIST

System SIRECUST 1280/1281 Bedside Monitor - Service Manual

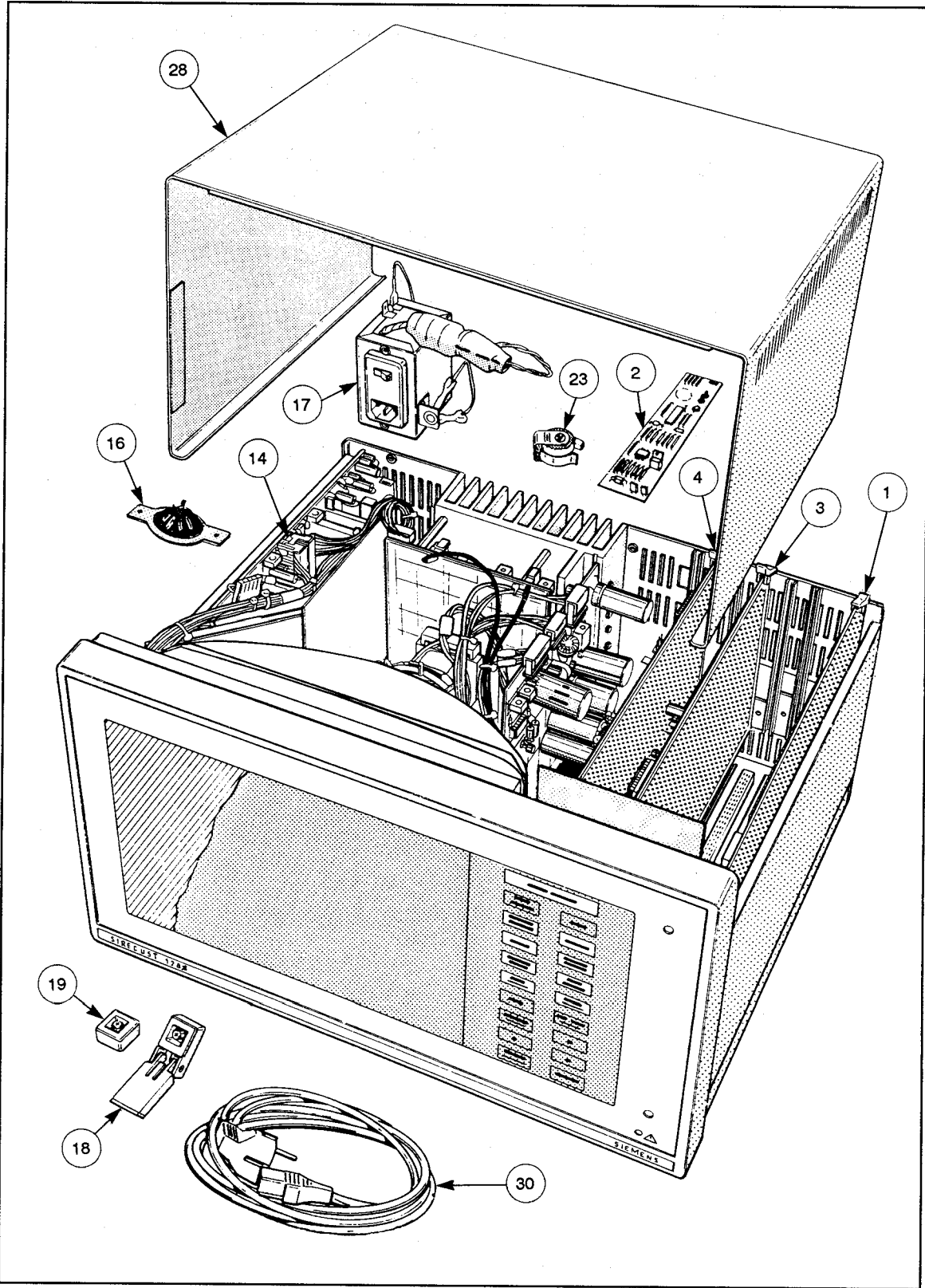

Figure A-1. SIRECUST 1280/1281 Monitor Parts/Assembly (Sheet 1 of 5)

System SIRECUST 1280/1281 Bedside Monitor - Service Manual

Table A-1. *Hardware Specifications*

<u>Item No.</u>	<u>Item</u>	<u>Specifications</u>	
101	SCREW	M3x12	DIN 7985
102	SCREW	M3x16	DIN 7985
103	SCREW	M4x10	DIN 7985
104	SCREW	M3x10	DIN 965
105	SCREW	M3x8	DIN 7985
106	SCREW	M2.5x8	DIN 7985
107	SCREW	M4x8	DIN 85
108	SCREW	M3x40	DIN 7985
109	SCREW	M3x12	DIN 965
120	WASHER	LOCK M3	DIN 137A
121	WASHER	M2.5	DIN 6798I
123	WASHER	M4	DIN 6798
124	WASHER	M4	DIN 127B
125	WASHER	M4	DIN 125
130	NUT	M2.5	DIN 934

System SIRECUST 1280/1281 Bedside Monitor - Service Manual

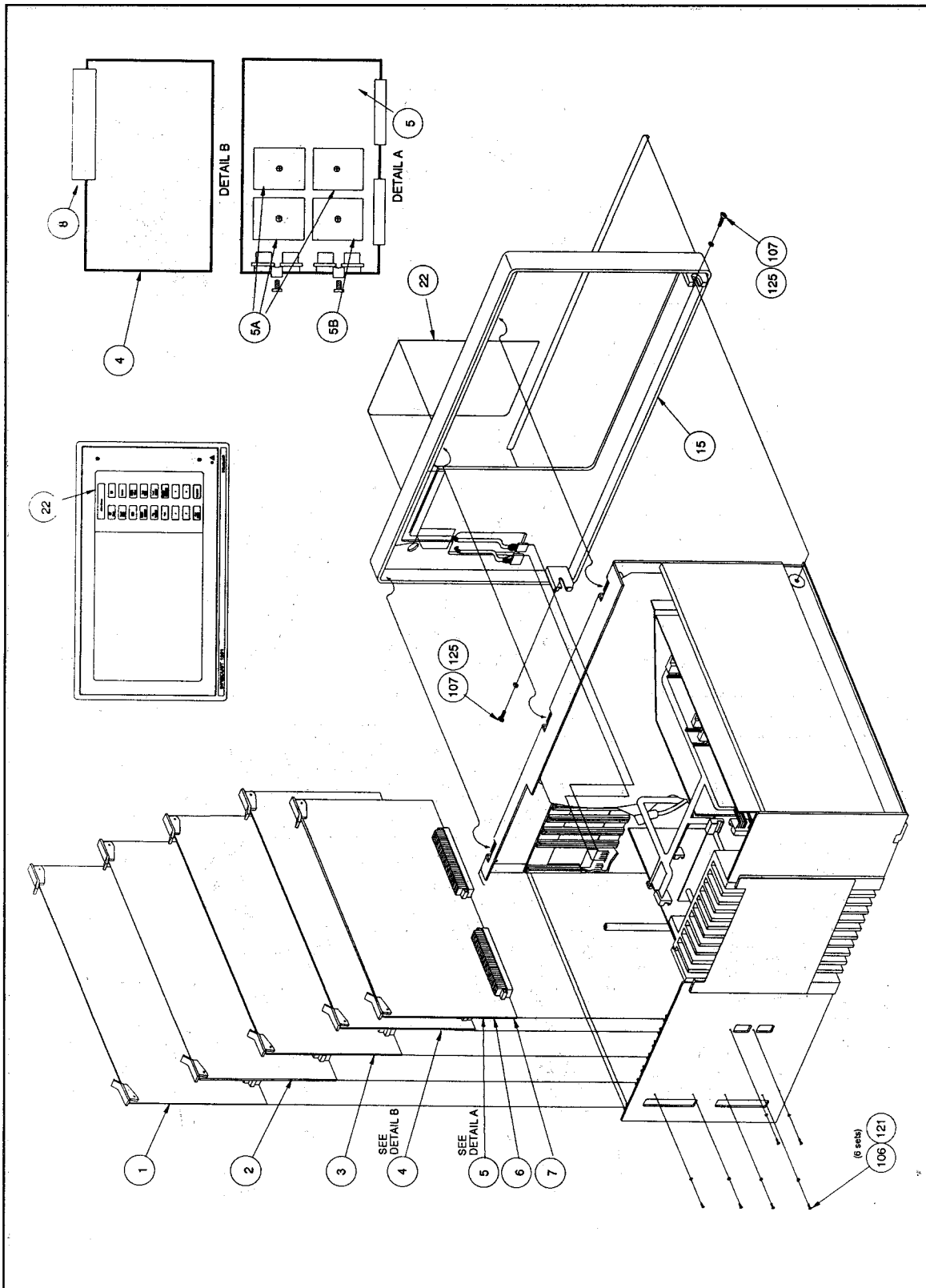

Figure A-2. SIRECUST 1280/1281 Monitor Parts/Assembly (Sheet 2 of 5)

System SIRECUST 1280/1281 Bedside Monitor - Service Manual

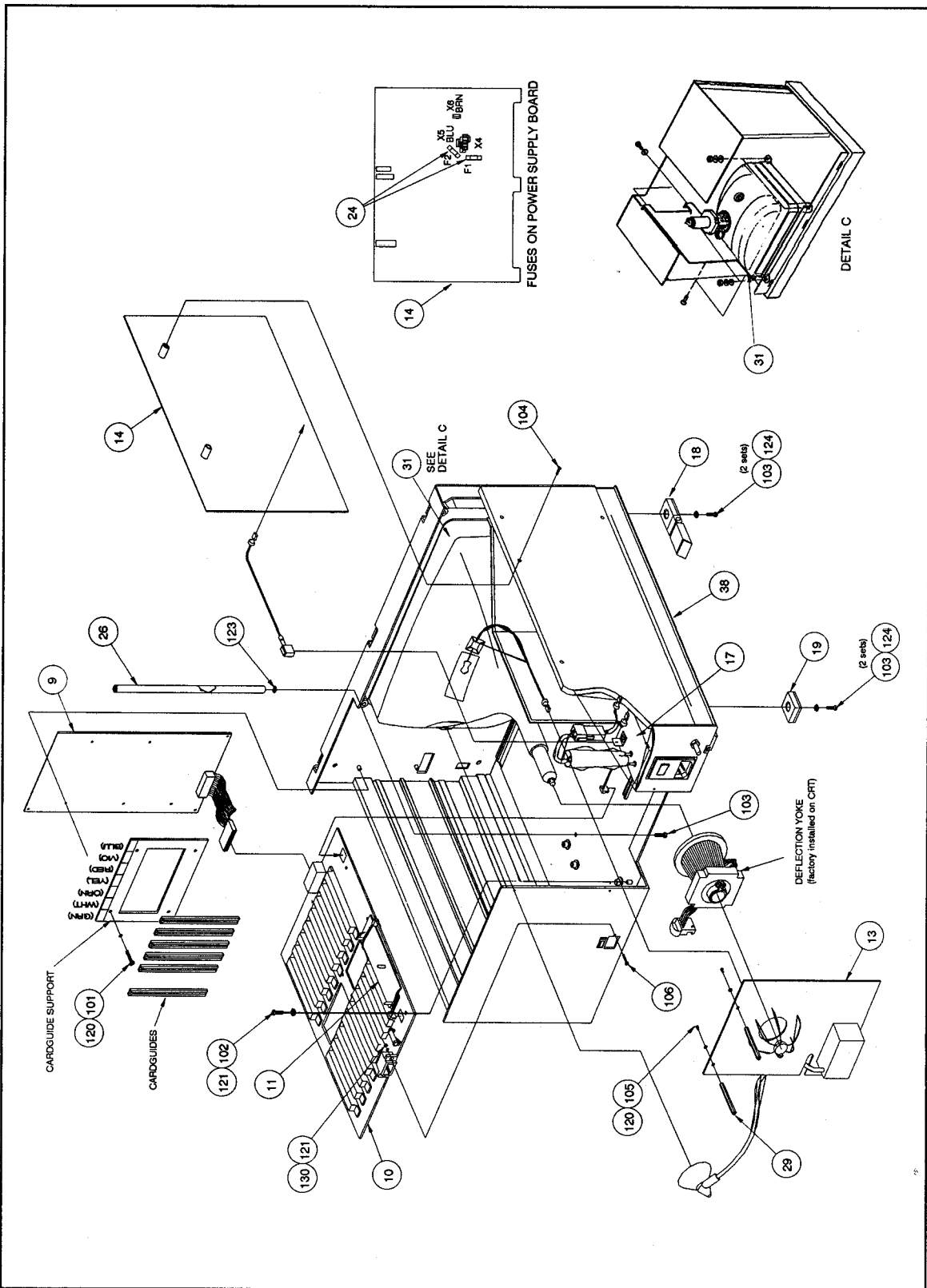

Figure A-3. SIRECUST 1280/1281 Monitor Parts/Assembly (Sheet 3 of 5)

System SIRECUST 1280/1281 Bedside Monitor - Service Manual

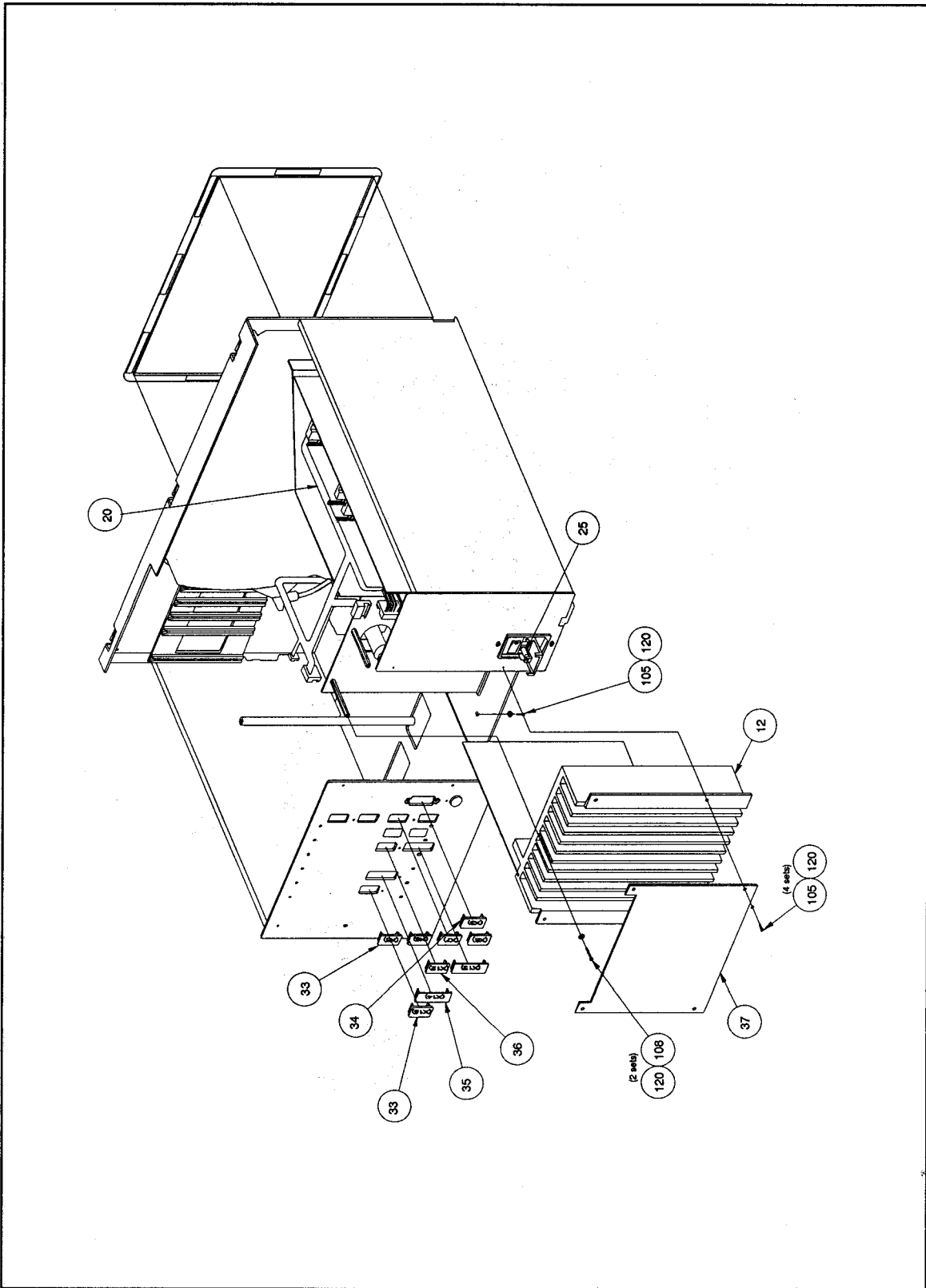

Figure A-4. SIRECUST 1280/1281 Monitor Parts/Assembly (Sheet 4 of 5)

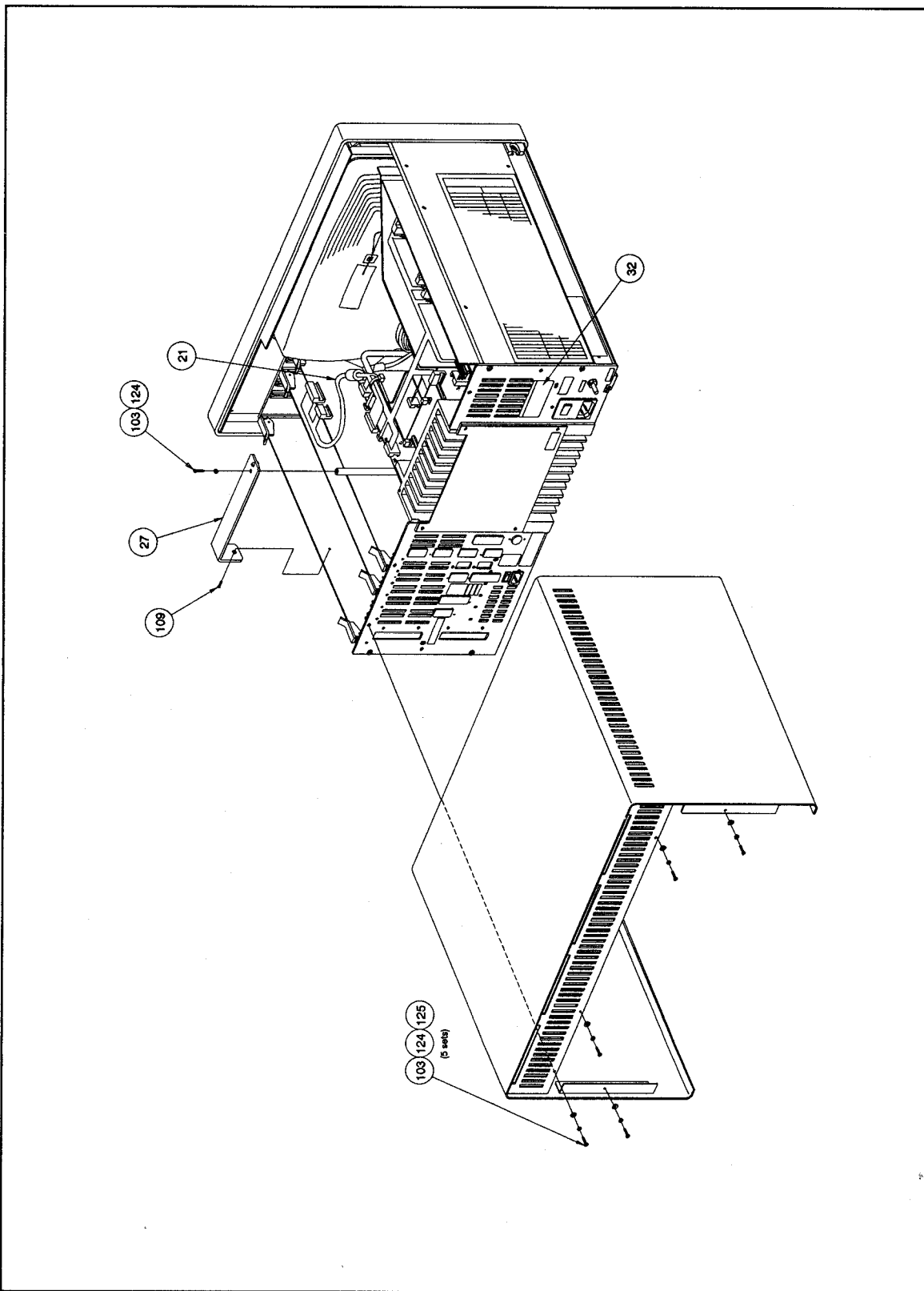

Figure A-5. SIRECUST 1280/1281 Monitor Parts/Assembly (Sheet 5 of 5)

System SIRECUST 1280/1281 Bedside Monitor - Service Manual

REPLACEMENT PARTS

<u>Item No.</u>	<u>Item Name</u>	<u>1280</u>	<u>1281</u>	<u>SIEMENS Art. No.</u>	<u>Fig.</u>
1.	Front End Board	*	*	87 91 378 E2501 A190	A-1,2
2.	Memory Extension Board	*	*	45 32 495 E2501 A400	A-2
3.	Display Processor Board Replaces Display Processor Boards A171/A371	*	*	45 35 696 E2500 A372	A-1,2
4.	Curve Board (1280)	*		87 91 402 E2500 A130	A-1,2
4.	Curve Board (1281)		*	87 91 667 E2500 A270	A-1,2
5.	Master Option Board	*	*	87 92 079 E2523 A810	A-2
5a.	RS232 Sub-option Board	*	*	87 92 087 E2523 A820	A-2
5b.	Analog Sub-option Board	*	*	87 92 103 E2523 A840	A-2
6.	4-Ch Analog Option Board	*	*	88 61 783 E2523 A971	A-2
7.	Clock Board	*	*	87 92 053 E2500 A960	A-2
8.	Line Driver Board	*	*	88 61 502 E2520 A300	A-2
9.	Operator Interface Board Replaces Operator Interface Board, A291	*	*	12 66 308 E2500 A292	A-3
10.	Motherboard	*	*	87 91 360 E2500 A100	A-3
11.	Memory Backup Board Replaces Battery Backup Board, A931	*	*	89 43 987 E2500 A933	A-1,3
12.	Deflection Board (incl. Heat Sink) (1280)	*		87 91 436 E2500 A160	A-4
12.	Deflection Board (incl. Heat Sink) (1281)		*	87 91 873 E2500 A310	A-4
13.	Z-Amp Board (1280)	*		87 91 857 E2500 A181	A-3
13.	Z-Amp Board (1281)		*	87 91 865 E2500 A261	A-3
14.	Power Supply (1280)	*		87 91 410 E2500 A140	A-1,3
14.	Power Supply (1281)		*	87 91 675 E2500 A280	A-1,3
15.	12" Color Shutter/ Front Frame Assembly		*	88 62 484 E2501	A-2
15.	12" TouchScreen/ Front Panel Assembly, Mono	*		88 62 500 E2501	A-2

REPLACEMENT PARTS (Continued)

<u>Item No.</u>	<u>Item Name</u>	<u>1280</u>	<u>1281</u>	<u>SIEMENS Art. No.</u>	<u>Fig.</u>
15.	12" TouchScreen/ Front Panel Assembly, Color		*	88 62 492 E2501	A-2
15.	12" Front Frame	*	*	85 39 371 E2501	A-2
16.	Speaker Assembly	*	*	30 42 777 B2603	A-1
17.	Line Filter Subassembly	*	*	88 61 791 E2501	A-1,3
18.	Foot-Tilt, Socket Assembly (2 ea)	*	*	87 93 143 E2504	A-1,3
19.	Foot-Straight Socket Assembly (2 ea)	*	*	87 93 192 E2504	A-1,3
20.	Pwr. Cbl. Assmb., 12" Chassis, Mono (A140/A100/A160/A181)	*		88 61 742 E2501	A-4
20.	Pwr. Cbl. Assmb., 12" Chassis, Color (A280/A100/A310/A261)		*	88 61 734 E2501	A-4
21.	Cable Assembly 12" Curve/Deflection (A270/A310 or A130/A160)	*	*	89 44 506 E2501	A-5
22.	12" Front Pnl. Lang. Insert, (DEU) PTB	*	*	89 43 649 E2501	A-2
22.	12" Front Pnl. Lang. Insert, (ENG)	*	*	85 40 635 E2501	A-2
22.	12" Front Pnl. Lang. Insert, (FR)	*	*	85 40 643 E2501	A-2
22.	12" Front Pnl. Lang. Insert, (SP)	*	*	85 40 650 E2501	A-2
23.	Battery Subassembly	*	*	88 61 775 E2500 A932	A-1
24.	B Fuse 5X20mm 2.5A 250V FAST	*	*	77 46 415 B1302	A-3
24.	B Fuse 5X20mm 2.5A 250V FAST	*	*	77 46 431 B1302	A-3
25.	B Fuse 5X20mm 4A 125V SLO BLO	*	*	77 46 456 B1302	A-4
25.	B Fuse 5X20mm 2.5A 250V SLO BLO	*	*	77 47 009 B1302	A-4
26.	Board Holddown Standoff	*	*	12 63 875 E2500	A-3
27.	Holddown Bar, 12" Subassembly	*	*	99 64 420 E2501	A-5
28.	Outer Case	*	*	99 64 438 E2501	A-1,5
29.	Standoff Mounting, Z Amp	*	*	12 64 105 E2500	A-3

System SIRECUST 1280/1281 Bedside Monitor - Service Manual

REPLACEMENT PARTS (Continued)

<u>Item No.</u>	<u>Item Name</u>	<u>1280</u>	<u>1281</u>	<u>SIEMENS Art. No.</u>	<u>Fig.</u>
30.	Power Cable, 2M EUROPA	*	*	70 18 195 B1948	A-1
30.	Power Cable, 3,1M UL	*	*	77 57 982 B1948	A-1
31.	12" Mono CRT Subassembly	*		88 61 569 E2501	A-3
31.	12" Color CRT Subassembly		*	88 61 585 E2501	A-3
32.	Nameplate (1280)	*		87 93 366 E2501	A-5
32.	Nameplate (1281)		*	87 94 208 E2501	A-5
33.	Conn Hole Plug 6 Pos	*	*	12 62 141 E2500	A-4
34.	Conn Hole Plug 8 Pos	*	*	12 62 158 E2500	A-4
35.	Conn Hole Plug 16 Pos	*	*	12 62 133 E2500	A-4
36.	Conn Hole Plug 4 Pos	*	*	12 62 166 E2500	A-4
37.	12XX Warning Plate	*	*	99 60 089 E500U	A-4
38.	Chassis 1280/1281	*	*	12 62 075 E2501	A-3

TABLE OF CONTENTS (Continued)

B-2.10.	Operator Interface Board, A291	Sheet 1 of 2	B-25
		2 of 2	B-26
B-2.11.	Power Supply (Mono), A140	Sheet 1 of 1	B-27
B-2.12.	Power Supply (Color), A280	Sheet 1 of 1	B-28
B-2.13.	Clock Board, A960	Sheet 1 of 2	B-29
		2 of 2	B-30
B-2.14.	Master Option Board, A810	Sheet 1 of 5	B-31
		2 of 5	B-32
		3 of 5	B-33
		4 of 5	B-34
		5 of 5	B-35
B-2.16.	Analog Sub-Option Board, A840	Sheet 1 of 1	B-36
B-2.17.	RS-232 Sub-Option Board, A820	Sheet 1 of 1	B-37
B-2.18.	Battery Board, A931	Sheet 1 of 1	B-38
B-2.19.	4-Ch. Analog Option Board, A971	Sheet 1 of 2	B-39
		2 of 2	B-40
B-2.20.	Memory Extension Board, A400	Sheet 1 of 2	B-41
		2 of 2	B-42
B-2.21.	Motherboard, A100	Sheet 1 of 2	B-43
		2 of 2	B-44
B-2.22.	Operator Interface Board, A292	Sheet 1 of 2	B-45
		2 of 2	B-46
B-2.23.	Memory Backup Board, A933	Sheet 1 of 1	B-47

SCHALTBILDER / WIRING DIAGRAMS

see Document E331.E2513.051.10.01.09 - File 2513941

siehe Unterlage E331.E2513.051.10.01.09 - File 2513941

APPENDIX C

PC BOARD JUMPER POSITIONS

APPENDIX C. Jumper Positions

The blocks in the following illustrations show the orientation of jumper blocks and the shading within the blocks show the recommended positions of jumpers for the specific boards identified. Different versions of boards may require different jumper settings or have different jumper block orientations. Always check that the illustration corresponds to the actual PC board before inserting jumpers or changing jumper settings.

NOTE: Jumper positions are software dependent. The illustrations in Figures C-1 thru C-4 are applicable to software versions VC, VE, and VF.

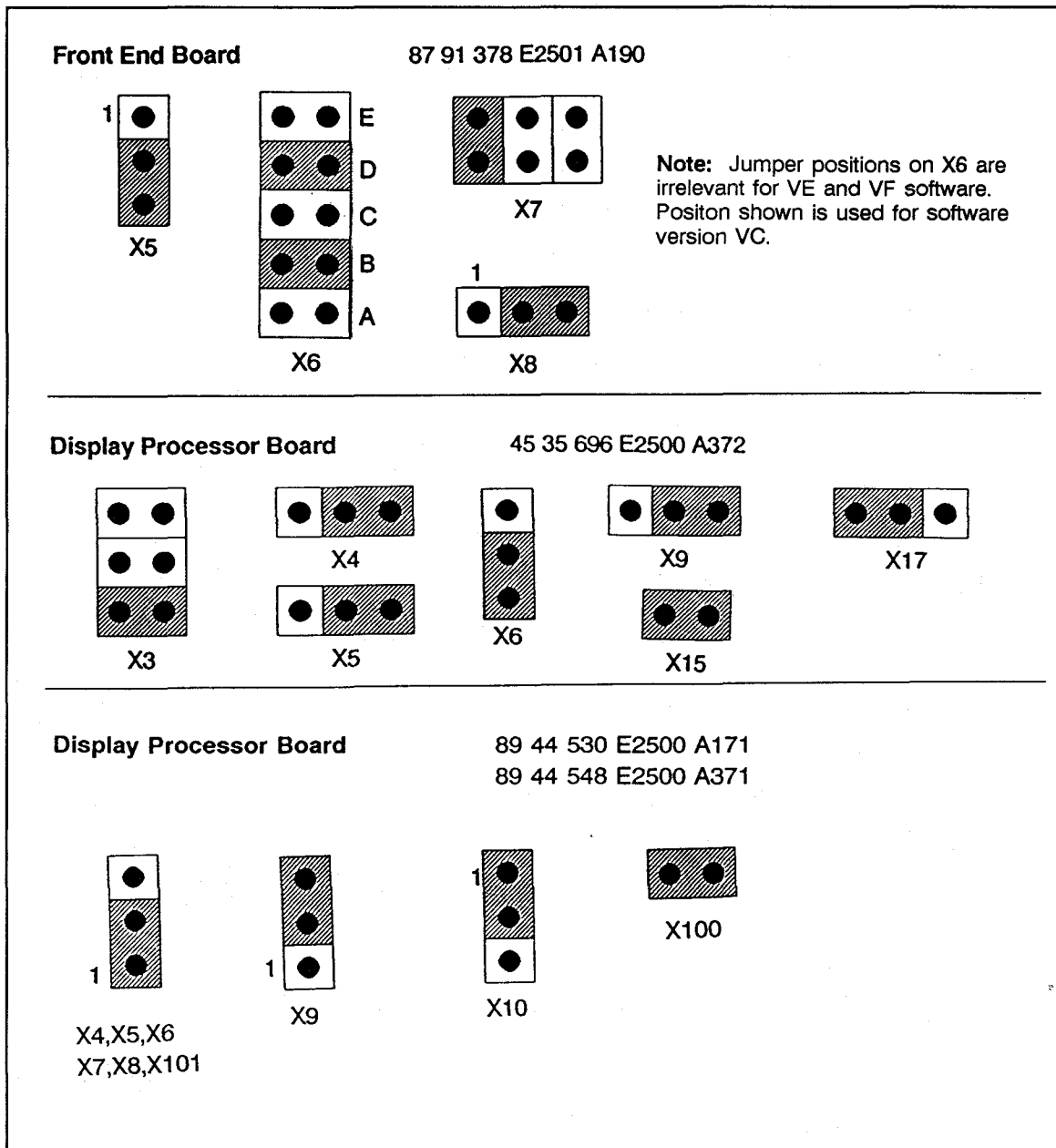

Figure C-1. PC BOARD Jumper Positions

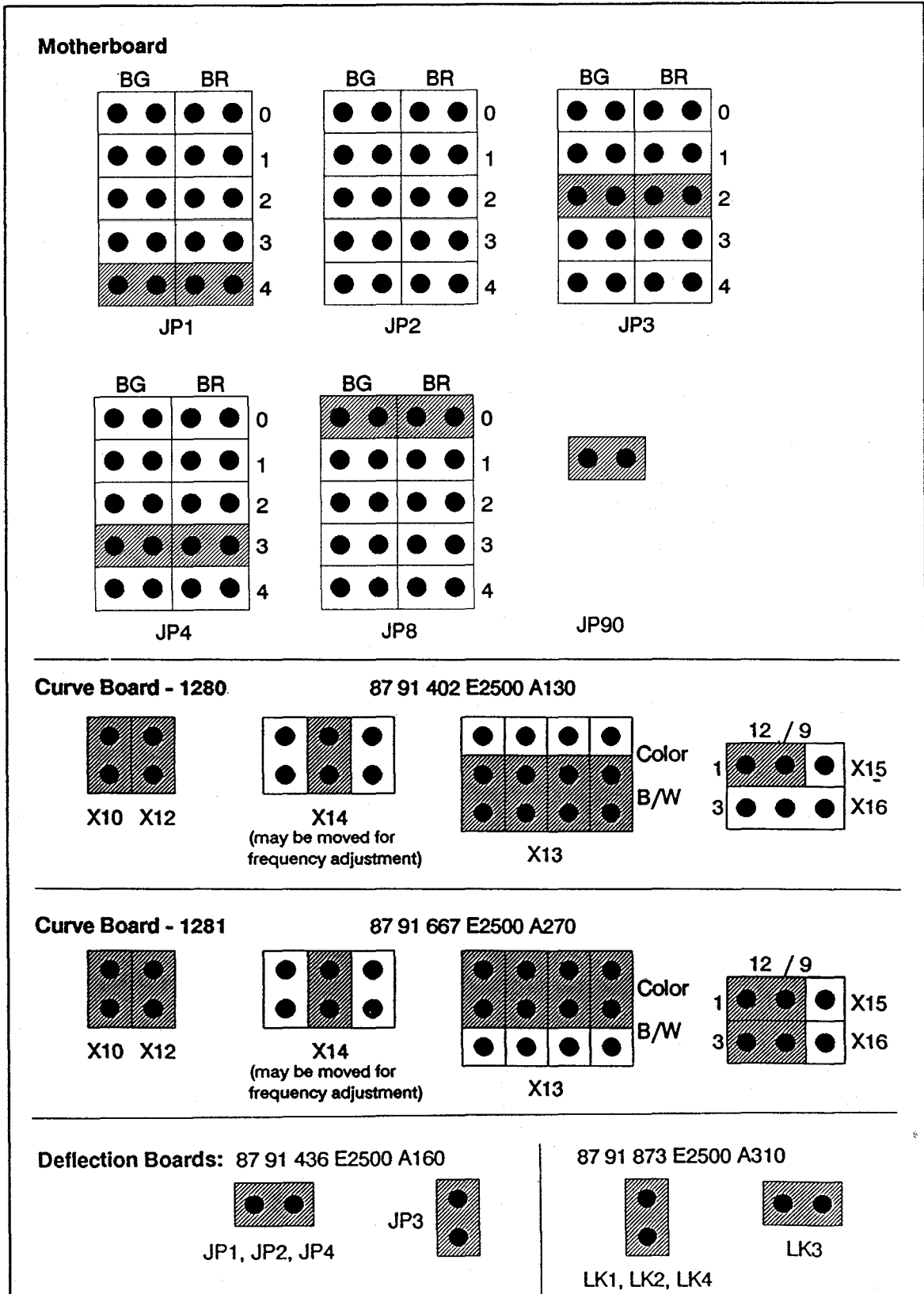

Figure C-2. PC Board Jumper Positions

System SIRECUST 1280/1281 Bedside Monitor - Service Manual

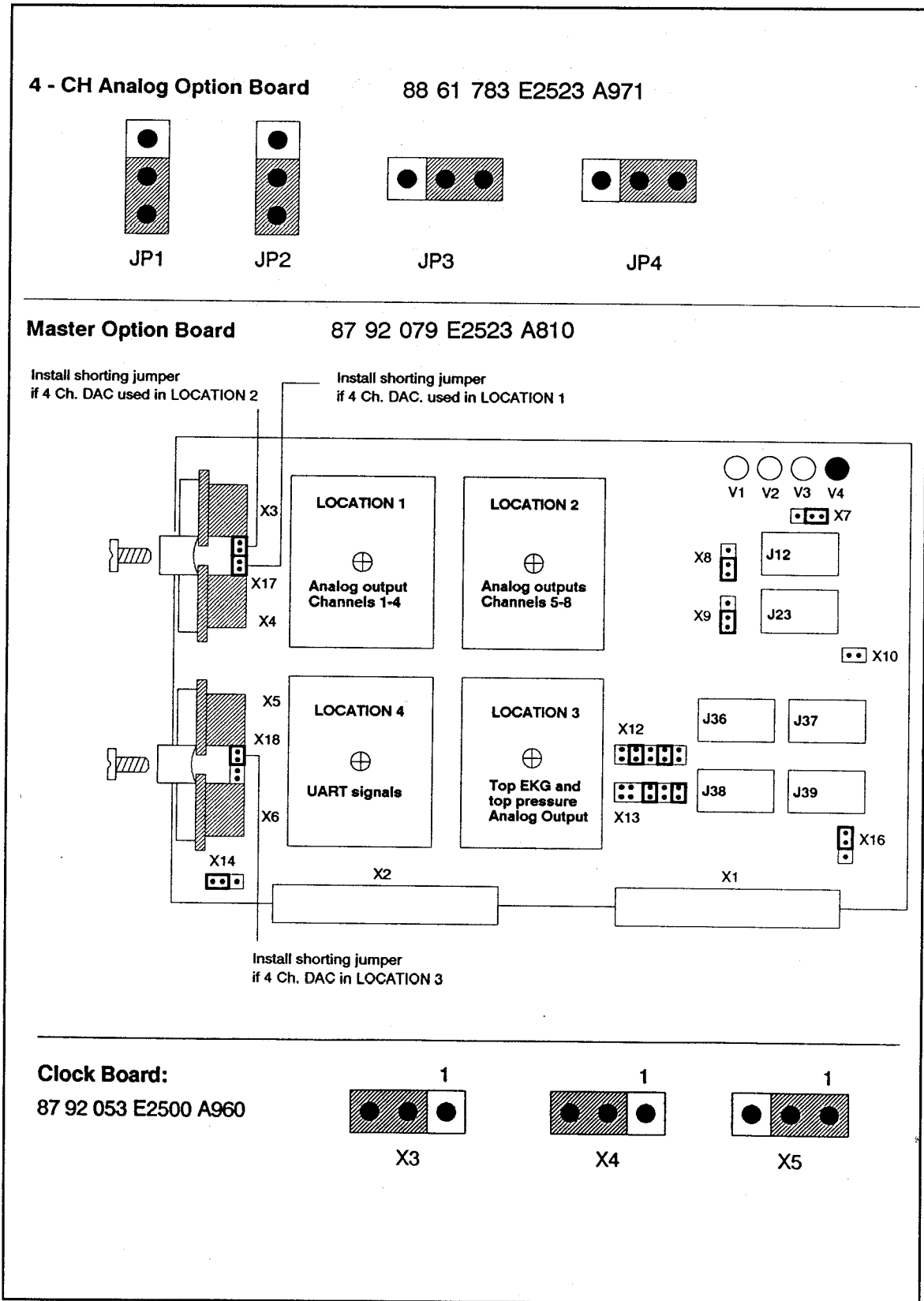

Figure C-3. PC Board Jumper Positions

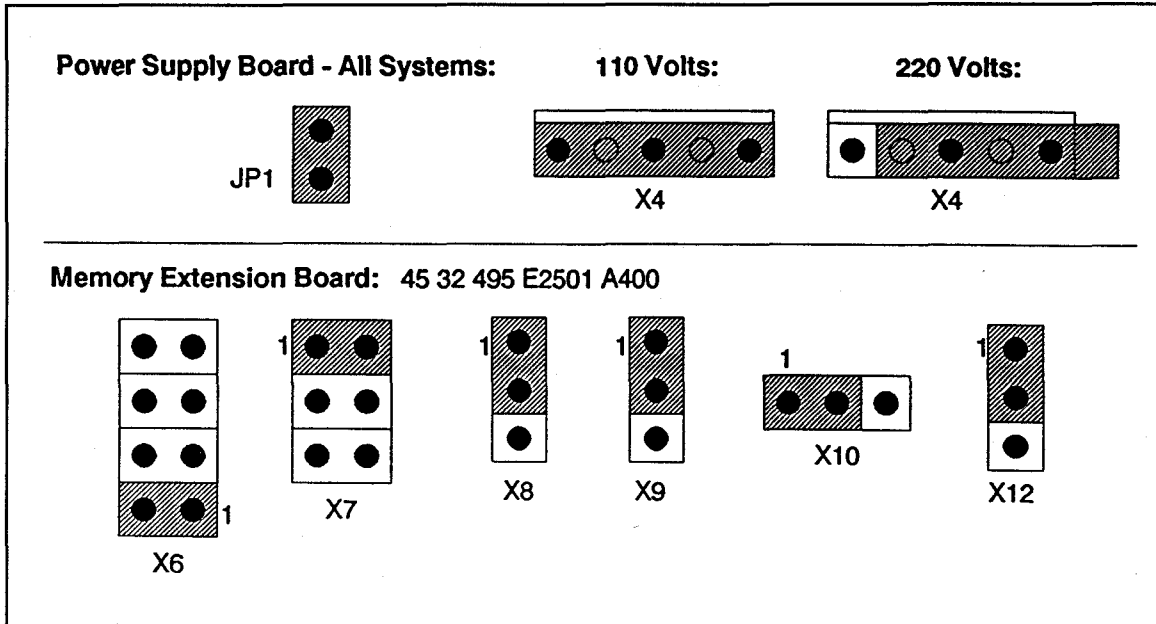

Figure C-4. PC Board Jumper Positions

APPENDIX D

GLOSSARY OF SIGNALS

TABLE OF CONTENTS

Power Supply	D-1
Front End Board, A190	D-1
Operator Interface Board, A292	D-2
Curve Board, A130/A270	D-3
Display Processor Board, A372	D-7
Deflection Board, A160/A310	D-9
Z-Amp Board, A181/A261	D-9
Battery Backup Board, A931	D-10
Master Option Board, A810	D-10
4-Channel Analog Sub-Option Board, A840	D-12
RS-232 Serial Sub-Option Board, A820	D-12

GLOSSARY OF SIGNALS

<u>SIGNAL NAME</u>	<u>SIGNAL MEANING</u>
<u>POWER SUPPLY BOARD A140/A280</u>	
AC INTO	Signal indicates pending main power failure.
SHUT DOWN	The signal switches output voltages of the power supply OFF when the voltage falls below the minimum supply voltage.
SLOW TURN ON	The signal slowly increases current limitation after the unit is switched ON.
 <u>FRONT END BOARD A190</u>	
14 CY INT	Strobe signal for serial data from SIREM.
A...D DAT	Multiplexed data lines from SIREM.
A...D AUX EN	Release of the auxiliary bits received by the module boxes onto the data bus.
A...D DATA EN	Release of the data bits received by the module boxes onto the data bus.
BATT	Battery-buffered supply voltage for SRAMs.
BG 3 L	Bus assignment by ARBITER (Display Processor Board A372.)
BR 3 L	Bus request of Front End Board A190.
BUS EN L	Internal bus enable signal.
BUS ERROR L	Bus error message. Signal is generated by the display processor.
CAS	Column address enable for DRAM.
CLK A1/A2/B1/B2	Serial data to SIREM 1.
CLK C1/C2/D1/D2	Serial data to SIREM 2.
CONT INT 1516 L	Signal clears serial input strobe (14 CY int.)
CS00L..CS13L	Chip select signals for EPROM, SRAM and DRAM.
DCSA 12..DCSD 12	Differential cartridge signals from SIREMs.
ENFE	Activation of the time control for module boxes.

GLOSSARY OF SIGNALS (Continued)

<u>SIGNAL NAME</u>	<u>SIGNAL MEANING</u>
<u>FRONT END BOARD A190 (Continued)</u>	
FIELD BIT	Signal FLD (refer to Curve Board A130/A270)
FSW1,FSW2	Foot switch SIREM 1,2, buffered.
LDA..LDD	Signal results in loading of data in the output register A..D.
MAC LL/UL	Internal enable of the data buffer.
Q3..Q5/Q11..Q17	Internal address lines.
R/W	Read/write signal.
RAS	Line address enable for DRAM.
REFRESH	Refresh request from display processor.
RESET L	System reset signal from display processor.
SEL0L	Selects Front End Board A190 for access by the display processor.
U/LA..U/LD	Multiplex control of CLK A..D.
UART INL/OUT	Serial data line for keyboard connection to SIREM 1,2.
WRITEL	Write signal from display processor.
<u>OPERATOR INTERFACE BOARD A292</u>	
AN2, AN3	Analog connections 2 and 3 of the microcontroller, not used.
BC IN	Decoded data of the bar code reader (not used).
BC OUT	Control data for bar code decoder (not used).
CTS	"Clear to send" message from display processor.
FEUR IN/ FEUR OUT (UART)	Serial data lines of the keyboard connections of the module boxes SIREM 1,2.
IR IN	Serial data from the infrared remote control (not used).
KEY IN/OUT	Serial data line of the keyboard connection to the rear panel of the unit (not used).

GLOSSARY OF SIGNALS (Continued)

<u>SIGNAL NAME</u>	<u>SIGNAL MEANING</u>
<u>OPERATOR INTERFACE BOARD A292 (Continued)</u>	
LR/G	Trigger signal for left LC shutter.
QX-Y MUX	Selection of X or Y position interrogation of the TouchScreen.
RR/G	Trigger signal for right LC shutter.
RX IN	Serial data line from the display processor.
SH1..SH4	Connections to the LC shutter.
TX OUT	Serial data to the display processor.
VDI	Pulses of the bar code reader (not used).
X-Y POS	Analog value of the X or Y position of the tactile touch on the TouchScreen.

CURVE BOARD A130/A270

AC1..8/11	Addresses A1..8/11 buffered.
AD DATA	Multiplexed address/data bus of the 8344.
ALARM	Signal, open collector, is set if the unit is in alarm condition.
ALARM/TIMEOUT	Signal, open collector, for time monitoring of the 68000. If no message arrives from the display processor within 5 seconds then this signal is set.
ALE	Storage of the address in the address latch of the 8344.
ASL	Address scanning, LOW-active, the signal is used to trigger the bus cycle.
BED	WAK connection recognition. The signal carries constant LOW or HIGH level, depending on connection 1 or 2 in the WAK, whereby the processor can set its call address for the central control station.
BLANK	Blanking generated by the graphics control. Control signal for vertical raster.
BLANKING	Blanking signal for blanking the electron beam by the blanking grid of the tube.

GLOSSARY OF SIGNALS (Continued)

<u>SIGNAL NAME</u>	<u>SIGNAL MEANING</u>
<u>CURVE BOARD A130/A270 (Continued)</u>	
BLKPT	Single-point blanking for curve depiction, is supplied by the curve memory.
CBLANK 1,2	Curve blanking signals
CBLANKL	Curve blanking, LOW-active. The signal generated by the programmable timing chain is used for format blanking of the curve display. It permits control of a sixth of the screen.
CEN	Channel enable. The signal is used to blank a curve.
CLR0	Clear interrupt register of the 8344.
CNS0/CNS1	Counter selection 0/1. Signals which are used to control the cyclical address sequence of the curve memory. This cyclical sequence can be set to 0.5, 1 or 2 kBytes.
COMM+/-	Symmetrical lines of the SIRENET connection.
CURVE	Analog signal of the amplitude of the display curve = Y-amp in curve mode.
DAC DATA	Curve amplitude, digital signals.
DACCLK	DAC clock. The signal is used to clock the curve data in the digital/analog converter.
DATA TR	Serial data of the SIRENET connection.
DS0L/DS1L	Data scanning 0 or 1 (refer to display processor).
FLD	Field. This signal is used to mark the two different video fields. In B/W mode, the signal marks rasters and curves. In color operation, the signal marks different color images. The image refresh frequency of the video field is 50 Hz.
FUNNEL	Funnel. This signal is used to enable the common RAM for the 8344 and the display processor.
HRES	Horizontal reset. The signal is used to reset the horizontal integrator for raster operation.
HSYNC	Horizontal synchronization signal (refer to display processor).
IN/OUT	Signal to control the transmission direction of the SIRENET.

GLOSSARY OF SIGNALS (Continued)

<u>SIGNAL NAME</u>	<u>SIGNAL MEANING</u>
<u>CURVE BOARD A130/A270 (Continued)</u>	
INTENSIFY	Address line to read out the brightness memory.
IRQ 4,5	Interrupts to the display processor.
K0...K13	Addresses for cyclical reading out of the curve memory.
LEFT R/G	Trigger signal for left LC shutter.
MDATA	Addresses, curve data memory.
MIDPT	Middle point. The signal serves to start the second address counter for curve operation with divided screen.
MIDPT EN	Enabling of the signal MIDPT.
MUX	Multiplexer. This signal is used to switch over from row and column address lines to the dynamic curve memory.
OE 0, OE 1	Output enable of the dynamic curve memories.
OWNP	The signal is used to enable the buffer of the common RAM to the data bus of the 8344.
PACE	The signal is used to mark an existing pacemaker pulse.
PGML	The signal blocks the programmable timing chain in order to permit programming.
PIXEL	Blanking of the tube during raster operation.
R/W	Read signal from display processor.
RAM 0	Chip select signal for the RAM of the 8344.
RAM AVL	Status signal of the 8344. Indicates who may have access to the common RAM.
RAS RET L	Line return pulse for raster depiction.
RASTER	Y-amplitude for raster depiction.
REFRESH	System refresh signal from display processor.
REG 0..7	Chip select signals for the registers.

GLOSSARY OF SIGNALS (Continued)

<u>SIGNAL NAME</u>	<u>SIGNAL MEANING</u>
<u>CURVE BOARD A130/A270 (Continued)</u>	
RET X-Y	X-Y return. The signal is used to mark the return time between beam deflections in curve operation.
RIGHT R/G	Trigger signal to control the right LC shutter.
ROM 0	Chip select signal for ROM of the 8344.
RST	Reset signal for 8344.
SC0...3	Deflection control. The signal is used to configure the deflection generator between slow and fast curves.
SCLK	Clock for serial data of SIRENET, is generated by the Manchester decoder for decoding.
SDATA	Data bus of the curve memory.
SEL	Initiation of bus cycles for the registers.
SELM	Memory selection, is generated by ASL and the curve memory address.
SH1...4	Color shutter driver signals.
SHCLK	Clock signal for the color shutter, with a frequency of 2 kHz.
SWPAST 2	Signal to reset the integrator which generates the horizontal saw-tooth voltage in curve operation.
SYNC OUT	QRS synchronization signal
SYS RESET L	System reset signal from display processor.
VRET	Vertical return. The signal is used to reset the vertical integrator for raster operation.
VSYNC	Vertical synchronization signal (refer to display processor).
W/R	Write signal of the display processor.
WP0/1	Write pulses for the curve memories.
WR	Write signal from 8344.
HORIZONTAL	Horizontal position of the electron beam of the tube.

GLOSSARY OF SIGNALS (Continued)
SIGNAL NAME**SIGNAL MEANING****CURVE BOARD A130/A270 (Continued)**

X-Y	Signal to distinguish between raster and curve operation.
VERTICAL	Vertical position of the electron beam of the tube.
Z	Controls intensity of electron beam in the CRT (brightness of display). Goes to VIDEO IN on Z-Amp Board.
Z DATA	Data bus of the 8344.

DISPLAY PROCESSOR BOARD A372

68 DSL	Lower data scanning of the 68000. Enabling of the low byte at LOW level.
68 DSU	Upper data scanning of the 68000. Enabling of the upper byte at LOW level.
AC FAIL	LOW-active if the $+5V_{DC}$ supply voltage falls below $+4.75V_{DC}$. The signal is generated on the battery board A931 and blocks use of the SRAMs.
AC LOW	Initiates an interrupt of highest priority in the processor if the mains voltage fails. The signal is generated on the power supply board A140/A280.
ALE	Signal for storage of the addresses for the DRAMs of the graphics controller.
ASL	Address scanning LOW-active. The signal is used to trigger the bus cycles.
B TRIP	The signal indicates whether the $+5V_{DC}$ supply to the SRAMs failed (refer to description of battery board A931) when the unit was switched OFF.
B0..B15	Multiplexed address/data line of the graphics controller.
BEEPER	Speaker signal.
BERRL	Bus error LOW-active, open-collector. Signal terminates the bus cycle in the VME bus when the bus time elapses or in the event of a parity error.
BG0..4	Bus assignment to other units by the ARBITER.

GLOSSARY OF SIGNALS (Continued)

<u>SIGNAL NAME</u>	<u>SIGNAL MEANING</u>
<u>DISPLAY PROCESSOR BOARD A372 (Continued)</u>	
BR0..4	Bus request of a unit (master in the VME bus) to the ARBITER.
C0..C7	Address lines of the DRAMs of the graphics controller.
CTS	"Clear to send" message to operator interface for serial transmission.
DS0L	Lower data scanning in the VME bus, LOW-active signal to enable the lower data byte.
DS1L	Upper data scanning in the VME bus, LOW-active signal to enable the upper data byte.
DTACKL	Data acknowledgment, LOW-active. Terminates the bus cycle in the VME bus if the data are ready.
EDTACK	External data acknowledgment, HIGH-active. Signal deactivates the bus cycles of the assembly.
FS1, FS2	Foot switch connections 1,2 of SIREM 1,2.
GCAS	Column address enable for DRAM of the graphics controller.
GCRD	Reading with graphic display control. The decoded address line is used for access to the graphics control in the read cycle.
GCWR	Writing with graphic display control. The decoded address line is used for access to the graphics control in the read cycle.
GDC CLK	Processor clock of the graphics controller, synchronized.
GRAS	Line address enable for DRAM of the graphics controller.
HSYNC	Horizontal synchronization signal. The signal is used for synchronization of the vertical raster lines.
IAS	Internal address scanning, LOW-active. The signal is used to trigger the 68000 cycle.
IDTACK	Internal data acknowledgment, HIGH-active. Signal is used to switch on the bus cycles of the assembly.
INTERRUPT 1..6	Interrupt lines for external requests.
IPL 0..2	Interrupt connections at the processor, LOW-active.

GLOSSARY OF SIGNALS (Continued)

<u>SIGNAL NAME</u>	<u>SIGNAL MEANING</u>
<u>DISPLAY PROCESSOR BOARD A372 (Continued)</u>	
IRQ	Interrupt signal from INTERRUPT 1...6.
L0..L15	Data line of the DRAMs of the graphics controller.
LCK0	Locking of the VME bus, LOW-active. The signal is used to block access by other processors to the VME bus during a read-modify-write cycle.
MIDPT	Middle point, is used to start the second address counter for curve operation with divided screen.
MTH	Middle point, HIGH-active, is used to switch over between the red and green memory levels.
PIXEL	Is used to blank the tube in raster operating mode. The signal is clocked with a frequency of 40 MHz.
PROC GND	Bus assignment for the 68000, LOW-active.
PROC REQ	Bus request of the 68000, LOW-active.
RAM 1, RAM 2	Chip select signals for SRAM of the 68000.
REF GND	Bus assignment to the refresh counter.
REF REQ	Bus request from refresh counter.
ROM 1, ROM 2	Chip select signals for ROM of the 68000.
SEL 0...5	Select signal for selection of the slaves.
UART R	Serial input for communication with the operator interface.
UART T	Serial output for communication with the operator interface.
VA IRQ	Interruptor request from the serial input.
VSYNC	Vertical synchronization signal. The signal is used for synchronization of the horizontal raster lines and field switchover.
<u>DEFLECTION BOARD A160/A310</u>	
CURRENT SENSE	Current measurement for limitation of the coil current for vertical deflection.

GLOSSARY OF SIGNALS (Continued)

<u>SIGNAL NAME</u>	<u>SIGNAL MEANING</u>
<u>DEFLECTION BOARD A160/A310 (Continued)</u>	
HOR+	Setpoint for horizontal deflection (X-AMP, Curve Board A130/A270).
VERT+	Setpoint for vertical deflection (Y-AMP, Curve Board A130/A270).
X-Y-H	Indicates whether raster or curve mode.

Z-AMP BOARD A181/A261

ACCELERATOR	Accelerating voltage at the tube.
BLANKING IN	Blanking pulse for beam blanking.
CATHODE	Cathode control - brightness of the pixel.
CONTROL	Blanking of the electron beam at the blanking grid.
ERROR VOLTAGE	DC error voltage
FOCUS	Focusing voltage at the tube.
VIDEO IN	Brightness setpoint from Curve Board. (same as Z on Curve Board)

BATTERY BACKUP BOARD A931

AC FAIL	Indicates mains failure.
BATR	Battery connection.
BCHRG	Signal switches the charging current between recharging and trickle charging current and resets BTRIP CIRCUIT.
BTRIP	Indicates whether the battery voltage failed and if data have thus been lost in the battery-buffered SRAM.
PIEZO	Signal to the piezo speaker.

MASTER OPTION BOARD A810

DS0L	Lower Data Strobe D<7:0>, LOW-True.
DS1L	Upper Data Strobe D<15:8>, HIGH-True.

GLOSSARY OF SIGNALS (Continued)

<u>SIGNAL NAME</u>	<u>SIGNAL MEANING</u>
<u>MASTER OPTION BOARD A810 (Continued)</u>	
DTACKL	Data Acknowledge, LOW-True.
WRITEL	System Read/Write, HIGH-Read, LOW-Write.
BERRL	System Bus Error, LOW-True.
BRL	System Bus Request, LOW-True.
BGL	System Bus Grant, LOW-True.
LCK0	Read-Modify-Write Lockout.
RESETL	System Reset, LOW-True.
SEL	Register Select Strobe, LOW-True.
IRQ1..IRQ3,IRQ6	System Interrupt, LOW True. Jumper Selectable, Default = IRQ1.
BATT	Static RAM Battery Backup
ACFAIL	AC Line Failure, 0V on failure.
ACLO	AC LOW - 0V indicates that the AC line is below low limit.
8MHZ	8 MHz Clock
40MHZ	40 MHz Clock
A01..A23	System Bus Address, HIGH-True
D00..D15	System Bus Data, HIGH-True
ASL	System Address Strobe, Open Collector LOW-True
SDL11..SDL16	Sub-Option Board 1 SDL I/O Connector (X4)
SDL21..SDL26	Sub-Option Board 2 SDL I/O Connector (X3)
SDL31..SDL38	Sub-Option Board 3 SDL I/O Connector (X6)
SDL41..SDL48	Sub-Option Board 4 SDL I/O Connector (X5)

GLOSSARY OF SIGNALS (Continued)

<u>SIGNAL NAME</u>	<u>SIGNAL MEANING</u>
<u>FOUR CHANNEL ANALOG SUB-OPTION BOARD A840</u>	
GND	Ground
DBD0..DBD7	Sub-Option Board Data, HIGH-True
ACHNLO	Analog Channel 0
ACHNL1	Analog Channel 1
ACHNL2	Analog Channel 2
ACHNL3	Analog Channel 3
DBSEL0	Sub-Option Board Select 0. -- loads lower 8 bits of D/A Conv.
DBSEL1	Sub-Option Board Select 1. -- loads upper 4 bits of D/A and 4 bit channel select code.
BRSTL	Reset. -- clears D/A and control registers.
SGND	Signal Ground.
<u>RS-232 SERIAL SUB-OPTION BOARD A820</u>	
DBRW	Sub-Option Board Read/Write. HIGH-Read, LOW-Write.
DBDSL	Sub-Option Board Data Strobe, LOW-True.
DBIRQ	Sub-Option Board Interrupt Request, LOW-True - Open Collector.
BE	Buffered "E" Clock
DB8	Buffered 8 MHz.
GND	Ground.
DBD0..DBD7	Sub-Option Board Data, HIGH-True.
RQ0	DMA Request, Receive Data.
RQ1	DMA Request, Transmit Data.
SDL1	Received Data, Channel 0.
SDL2	Clear to Send (CTS), Channel 0.

GLOSSARY OF SIGNALS (Continued)

<u>SIGNAL NAME</u>	<u>SIGNAL MEANING</u>
<u>RS-232 SERIAL SUB-OPTION BOARD A820 (Continued)</u>	
SDL3	Transmitted Data, Channel 0.
SDL4	Received Data, Channel 1.
SDL5	Signal Ground.
SDL6	Transmitted Data, Channel 1.
SDL7	Request to Send (RTS), Channel 0.
DBSELO	Sub-Option Board Select 0, chip select for devices.
DBA0, DBA1, DBA4, DBA5	Sub-Option Board Address, HIGH-True.
BRSTL	Reset, clears uPD71051 UARTS.

APPENDIX E
SUPPLEMENTAL INFORMATION

Buildable Test Equipment

SIRECUST 1280/1281 Bedside Monitors
&
Master Option Board

Self-Test and Error Messages

System SIRECUST 1280/1281 Bedside Monitor - Service Manual

E-1. Temperature Simulator Test Plug: Construct YSI 400 temperature probe simulator test plugs using SIEMENS Art. No. 46 65 519 B1945 plugs or equivalent.

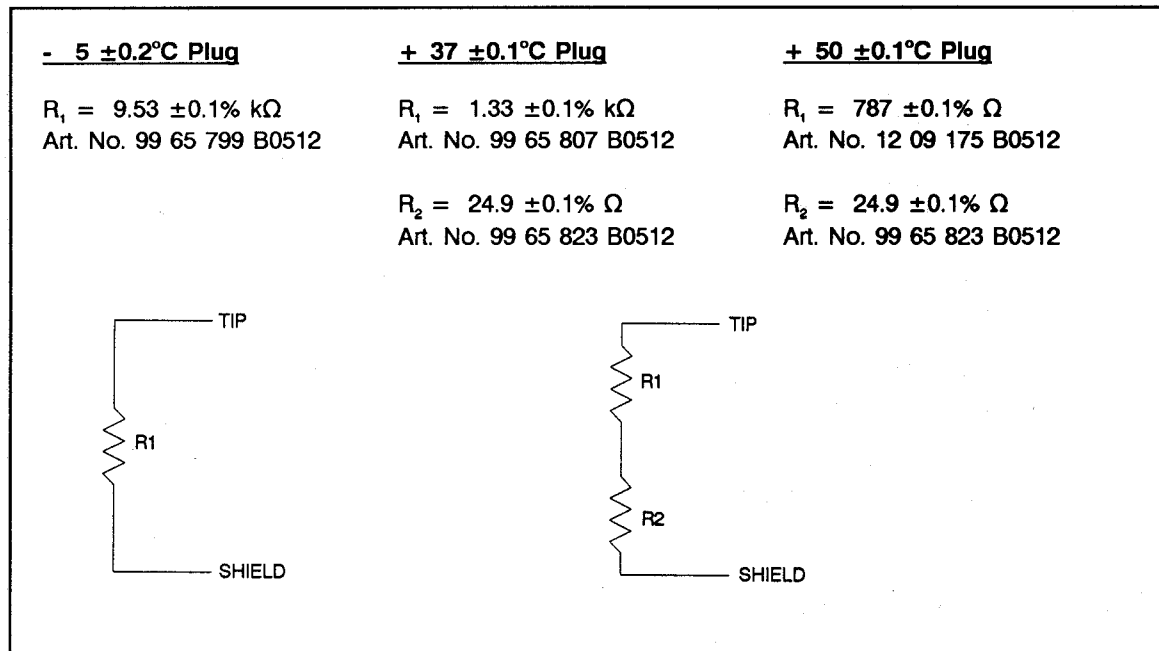

Figure E-1. Temperature Simulator Test Plug Resistance Configurations

1. Connect and solder the resistor(s) as shown in Figure E-1 for the selected test temperature.
2. Install the heat shrink tubing insulation on the resistor/plug assembly, and reinstall the plug case to complete simulator assembly. Refer to Figure E-2.

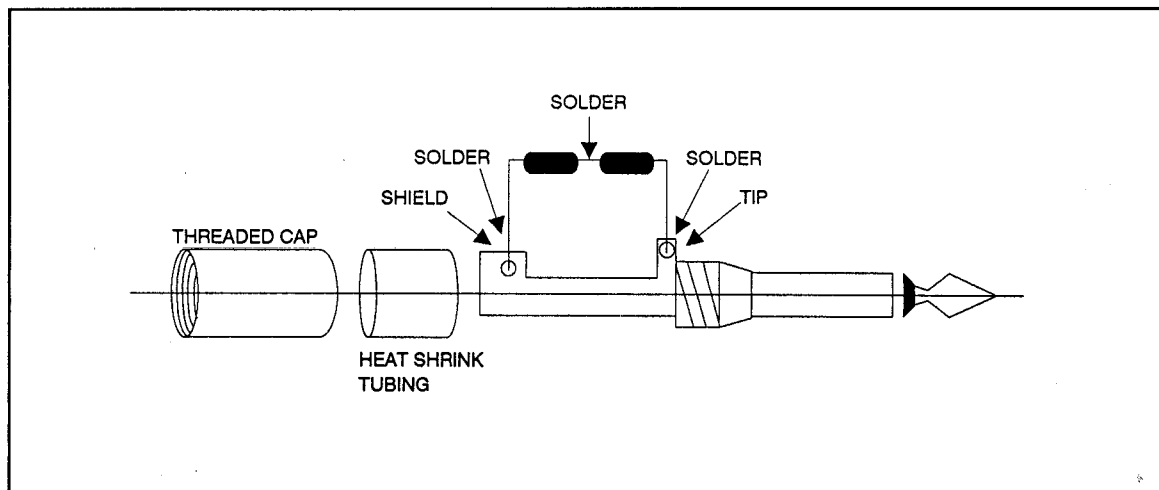

Figure E-2. Temperature Simulator Test Plug Assembly

E-2. Cardiac Output Test Plug: Construct a cardiac output test plug, using a SIEMENS Art. No. 73 68 640 E2260 plug or equivalent. Refer to Figure E-3.

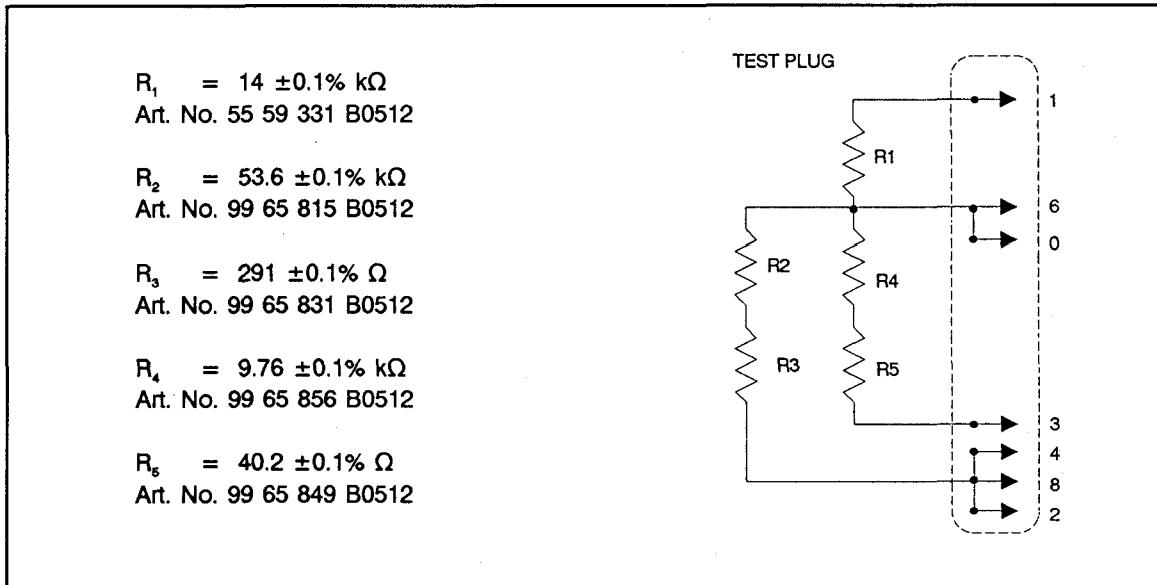

Figure E-3. Cardiac Output Test Plug Assembly

1. Connect and solder the resistor(s) as shown in Figure E-3 for the specified test temperature.
2. Install the heat shrink tubing insulation, and complete assembly of the simulator.

E.3. SIRECUST 1280/1281 Bedside Monitors**&****Master Option Board****Self-Tests and Error Messages****Software Versions VC, VE, and VF****TABLE OF CONTENTS**

E.3.1. Introduction	5
E.3.2. Network Error Messages	5
E.3.2.1. SIRENET Errors	5
E.3.2.2. SIRENET Diagnostics	6
E.3.3. Application Errors	6
E.3.4. Device Self-Tests	6
E.3.4.1. Start-Up Self-Tests	6
E.3.4.1.1. Summary Of Self-Test Messages	7
E.3.4.1.2. Background Online Self-Tests	7
E.3.4.1.3. Online Error Messages	8
E.3.4.2. Bedside Resets and "INTERNAL ERROR/MESSAGE" Screen	8
E.3.5. Master Option Board	8
E.3.5.1. Start Up Self-Tests	8
E.3.5.1.1. Background Online Self-Tests	8

LIST OF TABLES

Table 1: VC_ Software Error Messages	11
Table 1: VC_ Software Error Messages (continued)	12
Table 2: VE_ and VF_ Software Error Messages	13
Table 2: VE_ and VF_ Software Error Messages (continued)	14

E.3.1. Introduction

This document describes the self-tests and error messages of the SIRECUST 1280/1 and Master Option Board.

The software program of the 1280/1 and Master Option Board contain diagnostics that internally observe the performance of that software program. If the software program deviates from the preprogrammed standards set internally, during operation of the monitor, an error message is generated.

Network self-tests error messages, application error messages, and device self-tests/error messages are discussed in the following sections. Error messages are accompanied by a description of the probable cause of the error and a recommended action to be taken to resolve the fault.

NOTE: The self-tests and messages described in this document are for multiple software versions, and are identified as such, when required, by referencing specific versions within the text. The self-tests and messages of subsequent software versions may differ from those described.

E.3.2. Network Error Messages

Network error messages are associated with the SIRENET network. These error messages appear in the devices message window of the display screen. If two or more errors occur simultaneously, one displayed error message will be followed by the other.

E.3.2.1. SIRENET Errors

Status messages are given when a secondary device loses communication with the central station or when there is an error in the processing of alarms or recordings.

NOTE: XXXX normally indicates the device label. If the the device is unlabeled XXXX indicates the assigned trunkline number.

XXXX set offline, device limit, indicates that the permissible number of devices for that particular device-type has been exceeded, and is still connected to the network; e.g. a ninth recorder or a seventeenth bedside monitor.

XXXX set offline, system overload, indicates that the available central station memory is insufficient to accommodate a connected device.

XXXX set offline, wrong device, indicates that the device connected to the trunkline does not match the device-type assigned in the SITE SETUP.

FAILED, indicates that an information request made at a remote device is not available (e.g., cluster 4 in a 3 cluster system).

MISSED POLL INTERVAL(S), indicates that the clock in the secondary station has drifted ≥ 300 msec from the clock in the primary station, since the secondary came online. The cause is usually a clock timing problem within the secondary station or the central station, or both. If the crystals are within tolerance and the clock sync-register adjustment is working, the clocks should never drift that far apart.

NETWORK ALARM ERROR, indicates that the bedside monitor has gone into alarm, and the assigned central device **did not** respond with an acknowledgement for the alarm within 10 seconds. If a device is not assigned to a central or a remote cluster screen, network alarm errors **will** occur.

NO BED TO VIEW, indicates that no screen has been assigned to the remote device.

NO CONTINUOUS RECORDING, indicates that the system is unable to execute a continuous recording. The bedside monitor may not have a recorder assigned to it in the SITE SETUP.

NO COPY, indicates that the system is unable to execute a print screen command. The bedside monitor may not have a SIREDOC 220 assigned to it under the SITE SETUP, or the assigned SIREDOC 220 recorders are occupied with previous commands.

NO RECORDING, indicates that the system is unable to execute an alarm-initiated recording. Verify the recorder assignments in the SITE SETUP.

NO STRIP RECORDING, indicates that the system is unable to execute a strip-chart recording. The bedside monitor may not have a recorder assigned to it in the SITE SETUP.

OFFLINE, indicates that the secondary device is not on the SIRENET network.

E.3.2.2. SIRENET Diagnostics

The following diagnostic message refers to the SIRENET network. To enable or disable SIRENET diagnostic messages press the **DIAGNOSTIC MESSAGES ON/OFF** Keys.

To access these Keys, use the following sequence:

```

DISPLAY SET-UP
DIAGNOSTICS
FIELD SERVICE
(Password) ENTER
MONITORING SET-UP
  
```

NOTE: Diagnostic messages should be active (ON) only when a service representative is present. Set Diagnostic messages OFF for normal operation.

XXXX LOST, indicates that the trunkline for device XXXX is disconnected. If a

communication problem exists between central station and a secondary device, the messages XXXX LOST and XXXX FOUND will be alternately displayed.

E.3.3. Application Errors

The SIRECUST 1280/1 bedside monitor exhibits physiological and technical messages relating to alarms and parameter status in the display screen's status field. Application messages are listed and described in the System SIRECUST 1280/1281 Operating Instructions and subsequent operating supplements. Refer to Order number A91004-M3331-A079-xx-7600 for your specific software version.

E.3.4. Device Self-Tests

This section describes the start-up, on-line, and on-demand self-tests of each device.

E.3.4.1. Start-Up Self-Tests

The following tests are described in the order of execution after the unit has been switched ON. The name of the test in progress appears in the display message window, e.g.: TESTING FRONT END BOARD RAM

- a. If an error is detected during one of the subsequent tests, the software program exhibits the error in the message window and the program is interrupted. For example:

```

FRONT END BOARD RAM PROCESSOR STOPPED
ERROR ADR 048000 GOOD DATA 0123 BAD DATA 01F3
  
```

- b. During the self-test, the number of the test currently in progress is also indicated by the LEDs on the Operator Interface Board (as viewed from the rear of the monitor). The LEDs display a binary-coded number by illumination. An illuminated LED indicates logic level 1, a non-illuminated LED indicates logic level 0. The LED code is read from left to right.

System SIRECUST 1280/1281 Bedside Monitor - Service Manual

For example, if an error is detected during start-up self-test number 8, the processor stops and the LEDs located on the Operator Interface Board display the bit combination of 1000.

To compute the code displayed by the Operator Interface LEDs add up the values of the illuminated LEDs as follows:

<u>LED</u>	<u>VALUE</u>
V1	8
V2	4
V3	2
V4	1

A single LED flashing indicates an Operator Interface Board failure.

- c. The raster memory test differs from all other start-up self-tests in that the program repeats the test 10 times after detecting an error. If the program detects an additional error during the repetitions, it suspends the test and exhibits the error in the message window.

E.3.4.1.1. Summary Of Self-Test Messages

- a. Test Sequence 1 to 3:

If the monitor locks up, emits a continuous error tone, an error message is NOT exhibited on the CRT, and the LEDs of the Operator Interface Board do not provide detection, the problem may be related to the 68000 micro-processor, its primary program RAM, or an EPROM.

- b. Test Sequence 4 to 14:

Error messages are displayed on the CRT and/or the binary-coded test numbers appear on the LEDs on the Operator Interface board.

- c. Tests Sequence 9 to 12 (sw version VC) or Sequence 10 to 11 (sw version VE):

A faulty DRAM chip can be identified by differences in the GOOD DATA and BAD DATA values (as displayed on the CRT).

If the only difference is:

- the first digit: exchange J68
- the second digit: exchange J57
- the third digit: exchange J66
- the fourth digit: exchange J56

If more than one digit position is different, exchange the PC Board recommended in Table 1 or 2.

Software Tables 1 and 2 describe the tests in the order in which they are executed.

E.3.4.1.2. Background Online Self-Tests

The following tests are conducted automatically during monitor operation:

Program EPROM Online Self-Test: The checksum of the program EPROMs is continually calculated while the monitor is operating, and compared to the correct value stored internally. If an error is detected during this process, the monitor shuts down the curve display, exhibits a message that the processor has stopped, and identifies the error source.

Operator Interface Online Self-Test: The Operator Interface Board ROM, RAM, and ADC are continually checked while the monitor is in operation. If an error is detected a message indicating the source of the error is displayed on the screen.

Watchdog Timer of the 8344 Processor on the Curve Board: While the monitor is operating, a "monitoring time-generator program" checks communication between the 68000 located on the Display Pro-

cessor PC Board and the 8344 located on the Curve board. If an error is detected in either processor a continuous alarm sound is emitted and the message 8344 WATCHDOG ALARM is displayed.

E.3.4.1.3. Online Error Messages

If certain errors occur while a monitor is operating, an error message is displayed on the CRT. The messages and description of possible causes of Online Error Messages are as follows:

Unknown Operator Interface Error: The 68000 on the Display Processor board is having trouble communicating with the operator interface 68705.

Possible causes of problem:

- Problem with communication link between 68000 and 68705 (check hardware).
- Display Processor board.
- Software problem.

Unknown Spurious Interrupt: An interrupt was asserted on the 68000 that

cannot be processed. During the interrupt acknowledge cycle, no device responded to the 68000 with the appropriate DTACK or VPA signals.

Possible causes of problem:

- Display Processor board.
- Software problem.

E.3.4.2. Bedside Resets and "INTERNAL ERROR/ MESSAGE" Screen - sw versions VE_ and VF_.

See Figure E-4 and Figure E-5 for screen differences between the two software versions.

If an internal software error occurs and results in an internal state from which a bedside monitor cannot recover and still operate reliably, the monitor will automatically "reset". The screen will blank for a few seconds, and then function will resume as if the unit had been powered down and then back up. This clears all software errors and guarantees proper resumption of operation.

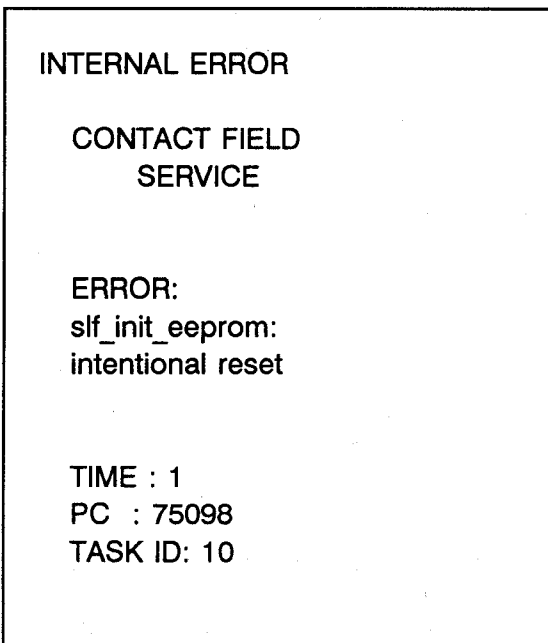

Figure E-4.

"INTERNAL ERROR" Screen

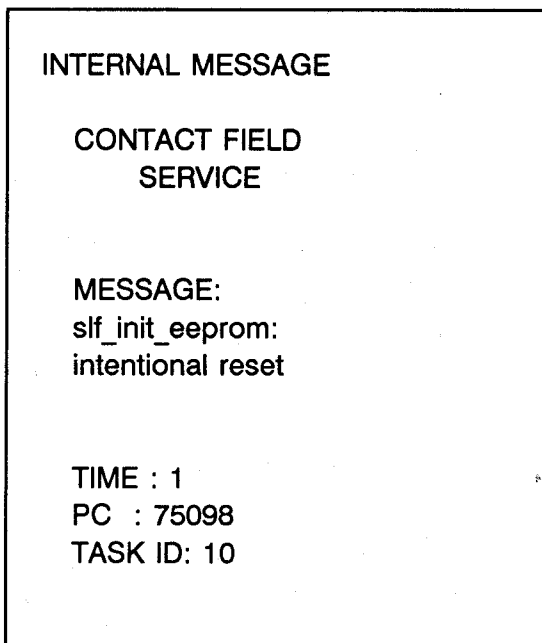

Figure E-5.

"INTERNAL MESSAGE" Screen

After such a reset, a special "INTERNAL ERROR/MESSAGE" screen is displayed listing information that allows SIEMENS software engineers to analyze the error and correct for the condition in a later sw version. Figure E-4 is an illustration of an "INTERNAL ERROR" screen for VE_ software, and Figure E-5 an "INTERNAL MESSAGE" screen for VF_ software. Forward a PRINT SCREEN of the error information and a full description of the steps leading to the error, via the standard complaint system, so that the error can be analyzed.

E.3.5. Master Option Board

This section describes the startup and online self-tests of the Master Option Board. A problem with the Master Option system is indicated by the binary code of the Master Option Board's LEDs, viewed from left to right. An illuminated LED indicates a logic condition 1. A non-illuminated LED is a logic condition 0.

E.3.5.1. Start Up Self-Tests

The Master Option Board (MOB) performs start-up tests on its RAM, ROM, and CPU. If errors are detected during this routine the MOB discontinues the test sequence and displays an LED binary code 0000. By checking the watchdog circuit the bedside monitor detects the interrupted MOB (see Section 5.1.1 below) and resets it. If the MOB continues to display an LED code 0000 replace the board.

E.3.5.1.1. Background Online Self-Tests

After completion of startup self-tests the MOB initiates a series of online tests. It displays the LED code 0001, flashing at a rate of 1 Hz, to indicate successful completion of the test. If an error is detected during the online self-test the MOB displays one of the following LED codes.

1100 (flashing at 1 Hz) - Sub-Option Board Configuration Error:

The MOB polls the identification and configuration of installed Sub-Option Boards. If an error is detected the MOB displays a flashing LED code of 1100. Refer to the MOB Hardware Installation Instructions A91004-M3331-T599-01-7600 for supported configurations.

If the Sub-Option Boards are found to be configured properly but the LED code 1100 still appears this usually indicates that one of the Sub-Option Boards is faulty.

0101 - Shared RAM Interface Test:

If the MOB detects an obstruction in the shared RAM interface path it displays the code 0101 to indicate a software error.

1111 (sw version VE_) - Watchdog Timer Self-Test:

A monitoring time-generator performs tests of the communication between the MOB processor and the bedside monitor processor. If a problem exists the Watchdog Timer expires and the MOB displays the LED code 1111. The monitor detects the MOB violating the watchdog scheme and resets the MOB. For VE_ software, the monitor also displays the message:

OMB WATCHDOG ALARM

For VF_ software, the monitor displays the message:

MOB WATCHDOG ALARM

1111 (sw version VF_) - MOB Configuration Test

Illumination of all four LEDs indicates that the MOB sub-option boards are improperly configured. Slots A, B, and D support only the 4-Ch. DAC sub-option

board, and slot C only the RS-232 sub-option board. During operation, an illuminated V3 indicates that the RS-232 board has received a message; an illuminated V2 indicates that the RS-232 has sent a message.

System SIRECUST 1280/1281 Bedside Monitor - Service Manual

SOFTWARE VERSION VC				
<u>TEST</u>	<u>PURPOSE OF TEST</u>	<u>ADDRESS AREA</u>	<u>POSSIBLE CAUSE</u>	<u>PC BOARD</u>
1	Initialization		PC Board	Display Processor A170/A370
1	Curve-Timing RAM		J 49	Curve Board A130/A270
2	Check of the internal 68000 registers		PC Board	Display Processor A170/A370
3	EPROM Checksum Test	11FFF1→11FFF3 11FFF5→11FFF7 11FFF9→11FFFB 11FFFD→11FFFF	J 28 J 27 J 43 J 42	Display Processor A170/A370
4	Curve Memory Test	40000→47FFF	J 32 J 43 J 52	Curve Board A130/A270
5	Raster Memory Test	0000→3FFF	J15→J18	Display Processor A170/A370
5		4000→7FFF (1281 ONLY)	J 7→J10	Display Processor A370
6	Data Memory Test	20000→2FFFF	J 60 J 61	Display Processor A170/A370
7	Checksum Test of program EPROMs	15FFF9→15FFFB 15FFFD→15FFFF	J 18 J 17	Front End Board A190
8	Front End Program Timing SRAMs	07C000→07FFFF	J42 J43	Front End Board A190
9	Front End Board DRAM Test	48000→4FFFF	Refer to Paragraph E.3.4.1.1.	Front End Board A190

Table 1: VC_ Software Error Messages

System SIRECUST 1280/1281 Bedside Monitor - Service Manual

SOFTWARE VERSION VC				
<u>TEST</u>	<u>PURPOSE OF TEST</u>	<u>ADDRESS AREA</u>	<u>POSSIBLE CAUSE</u>	<u>PC BOARD</u>
10	Front End Board DRAM Test	148000→14FFFF	Refer to Paragraph E.3.4.1.1.	Front End Board A190
11	Front End Board DRAM Test	248000→24FFFF	Refer to Paragraph E.3.4.1.1.	Front End Board A190
12	Front End DRAM Test	348000→34FFFF	Refer to Paragraph E.3.4.1.1.	Front End Board A190
14	Shared RAM Test 8344/68000 Processor	UNKNOWN 8344 FAILURE	J 18 J 38 J 48	Curve Board A130/A270
14	Shared RAM Test	SRAM ERROR FROM 68000 SIDE (COMM IS DOWN)	J 2, J95, J3	Curve Board A130/A270

Table 1: VC_ Software Error Messages (continued)

System SIRECUST 1280/1281 Bedside Monitor - Service Manual

SOFTWARE VERSIONS VE_ and VF_				
<u>TEST</u>	<u>PURPOSE OF TEST</u>	<u>ADDRESS AREA</u>	<u>POSSIBLE CAUSE</u>	<u>PC BOARD</u>
1	Initialization		PC Board	Display Processor A170/A370/A371/A372
1	Curve-Timing RAM		J 49	Curve Board A130/A270
2	Check of the internal 68000 registers		PC Board	Display Processor A170/A370/A371/A372
3	EPROM Checksum Test	11FFF1→11FFF3 11FFF5→11FFF7 11FFF9→11FFFB 11FFFD→11FFFF	J 28 J 27 J 43 J 42	Display Processor A170/A370/A371/A372
4	Curve Memory Test	40000→47FFF	J 32 J 43 J 52	Curve Board A130/A270
5	Raster Memory Test	00000→03FFF	J15→J18	Display Processor A170/A370/A371/A372
5		00000→07FFF 1281 ONLY	J7→J10	Display Processor A370/A371/A372
6	Data Memory Test	20000→2FFFF	J 60 J 61	Display Processor A170/A370/A371/A372
7	Memory Extension/ Front End Board EPROMs (listed as Front End ROMs on Error Screen Message)	3FFFF1→3FFFF3 3FFFF5→3FFFF7 3FFFF9→3FFFFB 3FFFFD→3FFFFF	J 18 J 17 J 34 J 33	Memory Extension Board A400
8	Front End Program Timing SRAMs	0F0000→0FFFFF	J 42, J 43	Front End Board A190
10	Front End Board DRAM Test	048000→04FFFF 148000→14FFFF 248000→24FFFF 348000→34FFFF	Refer to paragraph E.3.4.1.1	Front End Board A190

Table 2: VE_ and VF_ Software Error Messages

System SIRECUST 1280/1281 Bedside Monitor - Service Manual

SOFTWARE VERSIONS VE_ and VF_ (Continued)				
<u>TEST</u>	<u>PURPOSE OF TEST</u>	<u>ADDRESS AREA</u>	<u>POSSIBLE CAUSE</u>	<u>PC BOARD</u>
11	Memory Extension Board DRAM Test (called Front End board RAM in error message screen)	0C8000→0CFFFF 1C8000→1CFFFF 2C8000→2CFFFF 3C8000→3CFFFF	Refer to paragraph E.3.4.1.1	Extension Memory Board A400
12	Memory Extension DRAM Parity			Extension Memory Board A400
14	Shared RAM Test of 8344/68000 Processor	UNKNOWN 8344 FAILURE	J 18 J 38 J 48	Curve Board A130/A270
14	Shared RAM Test	SRAM ERROR FROM 68000 SIDE (COMM IS DOWN)	J 2, J95, J3	Curve Board A130/A270

Table 2: VE_ and VF_ Software Error Messages (continued)

APPENDIX F

FUNCTIONAL VERIFICATION/ PERFORMANCE CHECKLISTS

SIRECUST 1280/1281 BEDSIDE MONITOR FUNCTIONAL VERIFICATION/PERFORMANCE CHECKLIST

The Section numbers listed below correspond to the sections in which the testing and/or calibration procedures are outlined in Chapter 5, Functional Verification, and Chapter 7, Calibration/Adjustment.

SITE: _____ DATE: _____ TECH: _____

MONITOR:(Check)1280 _____ 1281 _____ SERIAL NO: _____

<u>FUNCTION TESTED</u>	<u>SECTION #</u>	<u>FUNCTION OK</u>
<u>Chapter 5. Functional Verification</u>		
Speaker	5.3.1.	_____
Green LED Illumination	5.3.2.	_____
Monitor Power	5.3.3.	_____
TouchScreen Keys	5.3.4.	_____
Display Alignment	5.3.5.	
Raster and Curve Alignment	5.3.5.1.	_____
Colors	5.3.5.2.	_____
Ambient Light Sensor	5.3.6.	_____
Digital I/O	5.3.7.	_____
Monitor Shutdown	5.4.1.	_____
Input and Display	5.4.2.	
Display Agreement with Operating Instructions	5.4.2.5.	_____
Display Interference Free	5.4.2.6.	_____
Display Agreement with Operating Instructions	5.4.2.9.	_____
Display Remains Interference Free	5.4.2.10.	_____
Overall Monitor Function	5.5.	
♥ Symbol	1a.	_____
QRS Volume Keys	1b.	_____
Curve Sweep	2.	_____
Intensity Control	3.	_____
Pacer Detection	4A or 4B.	_____
Memory Backup	5.5.1.	_____

FUNCTIONAL VERIFICATION CHECKLIST (Continued)

<u>FUNCTION TESTED</u>	<u>SECTION #</u>	<u>FUNCTION OK.</u>
Lead-Off	5.5.2.	_____
Cable Unplugged	5.5.3.	_____
Temperature	5.5.4.	_____
Cardiac Output	5.5.5.	_____
Alarms	5.5.6.	_____
Advisory	5.5.6.1 or 2.	_____
Serious	5.5.6.3.	_____
Life Threatening	5.5.6.4.	_____
Communication	5.6.	_____
Screen Recording	5.6.1.	_____
Continuous Recording	5.6.2.	_____
Leakage Current	5.7.	_____
<u>Chapter 7. Calibration/Adjustment</u>		
Main Power Supply Voltages	7.1.	_____
+5 V _{DC} Supply	7.1.1.	_____
+15 V _{DC} Supply	7.1.2.	_____
High Voltage Supply	7.2.	_____

**SIRECUST 1280/1281 BEDSIDE MONITOR
FUNCTIONAL VERIFICATION/PERFORMANCE CHECKLIST**

The Section numbers listed below correspond to the sections in which the testing and/or calibration procedures are outlined in Chapter 5, Functional Verification, and Chapter 7, Calibration/Adjustment.

SITE: _____ DATE: _____ TECH: _____

MONITOR:(Check)1280 _____ 1281 _____ SERIAL NO: _____

<u>FUNCTION TESTED</u>	<u>SECTION #</u>	<u>FUNCTION OK</u>
<u>Chapter 5, Functional Verification</u>		
Speaker	5.3.1.	_____
Green LED Illumination	5.3.2.	_____
Monitor Power	5.3.3.	_____
TouchScreen Keys	5.3.4.	_____
Display Alignment	5.3.5.	_____
Raster and Curve Alignment	5.3.5.1.	_____
Colors	5.3.5.2.	_____
Ambient Light Sensor	5.3.6.	_____
Digital I/O	5.3.7.	_____
Monitor Shutdown	5.4.1.	_____
Input and Display	5.4.2.	_____
Display Agreement with Operating Instructions	5.4.2.5.	_____
Display Interference Free	5.4.2.6.	_____
Display Agreement with Operating Instructions	5.4.2.9.	_____
Display Remains Interference Free	5.4.2.10.	_____
Overall Monitor Function	5.5.	_____
♥ Symbol	1a.	_____
QRS Volume Keys	1b.	_____
Curve Sweep	2.	_____
Intensity Control	3.	_____
Pacer Detection	4A or 4B.	_____
Memory Backup	5.5.1.	_____

FUNCTIONAL VERIFICATION CHECKLIST (Continued)

<u>FUNCTION TESTED</u>	<u>SECTION #</u>	<u>FUNCTION OK</u>
Lead-Off	5.5.2.	_____
Cable Unplugged	5.5.3.	_____
Temperature	5.5.4.	_____
Cardiac Output	5.5.5.	_____
Alarms	5.5.6.	_____
Advisory	5.5.6.1 or 2.	_____
Serious	5.5.6.3.	_____
Life Threatening	5.5.6.4.	_____
Communication	5.6.	_____
Screen Recording	5.6.1.	_____
Continuous Recording	5.6.2.	_____
Leakage Current	5.7.	_____
<u>Chapter 7. Calibration/Adjustment</u>		
Main Power Supply Voltages	7.1.	_____
+5 V _{DC} Supply	7.1.1.	_____
+15 V _{DC} Supply	7.1.2.	_____
High Voltage Supply	7.2.	_____

**SIRECUST 1280/1281 BEDSIDE MONITOR
FUNCTIONAL VERIFICATION/PERFORMANCE CHECKLIST**

The Section numbers listed below correspond to the sections in which the testing and/or calibration procedures are outlined in Chapter 5, Functional Verification, and Chapter 7, Calibration/Adjustment.

SITE: _____ **DATE:** _____ **TECH:** _____

MONITOR:(Check)1280 _____ **1281** _____ **SERIAL NO:** _____

<u>FUNCTION TESTED</u>	<u>SECTION #</u>	<u>FUNCTION OK</u>
<u>Chapter 5, Functional Verification</u>		
Speaker	5.3.1.	_____
Green LED Illumination	5.3.2.	_____
Monitor Power	5.3.3.	_____
TouchScreen Keys	5.3.4.	_____
Display Alignment	5.3.5.	
Raster and Curve Alignment	5.3.5.1.	_____
Colors	5.3.5.2.	_____
Ambient Light Sensor	5.3.6.	_____
Digital I/O	5.3.7.	_____
Monitor Shutdown	5.4.1.	_____
Input and Display	5.4.2.	
Display Agreement with Operating Instructions	5.4.2.5.	_____
Display Interference Free	5.4.2.6.	_____
Display Agreement with Operating Instructions	5.4.2.9.	_____
Display Remains Interference Free	5.4.2.10.	_____
Overall Monitor Function	5.5.	
♥ Symbol	1a.	_____
QRS Volume Keys	1b.	_____
Curve Sweep	2.	_____
Intensity Control	3.	_____
Pacer Detection	4A or 4B.	_____
Memory Backup	5.5.1.	_____

FUNCTIONAL VERIFICATION CHECKLIST (Continued)

<u>FUNCTION TESTED</u>	<u>SECTION #</u>	<u>FUNCTION OK</u>
Lead-Off	5.5.2.	_____
Cable Unplugged	5.5.3.	_____
Temperature	5.5.4.	_____
Cardiac Output	5.5.5.	_____
Alarms	5.5.6.	_____
Advisory	5.5.6.1 or 2.	_____
Serious	5.5.6.3.	_____
Life Threatening	5.5.6.4.	_____
Communication	5.6.	_____
Screen Recording	5.6.1.	_____
Continuous Recording	5.6.2.	_____
Leakage Current	5.7.	_____
<u>Chapter 7, Calibration/Adjustment</u>		
Main Power Supply Voltages	7.1.	_____
+5 V _{DC} Supply	7.1.1.	_____
+15 V _{DC} Supply	7.1.2.	_____
High Voltage Supply	7.2.	_____

**SIRECUST 1280/1281 BEDSIDE MONITOR
FUNCTIONAL VERIFICATION/PERFORMANCE CHECKLIST**

The Section numbers listed below correspond to the sections in which the testing and/or calibration procedures are outlined in Chapter 5, Functional Verification, and Chapter 7, Calibration/Adjustment.

SITE: _____ DATE: _____ TECH: _____

MONITOR: (Check) 1280 _____ 1281 _____ SERIAL NO: _____

<u>FUNCTION TESTED</u>	<u>SECTION #</u>	<u>FUNCTION OK</u>
<u>Chapter 5, Functional Verification</u>		
Speaker	5.3.1.	_____
Green LED Illumination	5.3.2.	_____
Monitor Power	5.3.3.	_____
TouchScreen Keys	5.3.4.	_____
Display Alignment	5.3.5.	_____
Raster and Curve Alignment	5.3.5.1.	_____
Colors	5.3.5.2.	_____
Ambient Light Sensor	5.3.6.	_____
Digital I/O	5.3.7.	_____
Monitor Shutdown	5.4.1.	_____
Input and Display	5.4.2.	_____
Display Agreement with Operating Instructions	5.4.2.5.	_____
Display Interference Free	5.4.2.6.	_____
Display Agreement with Operating Instructions	5.4.2.9.	_____
Display Remains Interference Free	5.4.2.10.	_____
Overall Monitor Function	5.5.	_____
♥ Symbol	1a.	_____
QRS Volume Keys	1b.	_____
Curve Sweep	2.	_____
Intensity Control	3.	_____
Pacer Detection	4A or 4B.	_____
Memory Backup	5.5.1.	_____

FUNCTIONAL VERIFICATION CHECKLIST (Continued)

<u>FUNCTION TESTED</u>	<u>SECTION #</u>	<u>FUNCTION OK</u>
Lead-Off	5.5.2.	_____
Cable Unplugged	5.5.3.	_____
Temperature	5.5.4.	_____
Cardiac Output	5.5.5.	_____
Alarms	5.5.6.	
Advisory	5.5.6.1 or 2.	_____
Serious	5.5.6.3.	_____
Life Threatening	5.5.6.4.	_____
Communication	5.6.	
Screen Recording	5.6.1.	_____
Continuous Recording	5.6.2.	_____
Leakage Current	5.7.	_____
<u>Chapter 7, Calibration/Adjustment</u>		
Main Power Supply Voltages	7.1.	
+5 V _{DC} Supply	7.1.1.	_____
+15 V _{DC} Supply	7.1.2.	_____
High Voltage Supply	7.2.	_____

**SIRECUST 1280/1281 BEDSIDE MONITOR
FUNCTIONAL VERIFICATION/PERFORMANCE CHECKLIST**

The Section numbers listed below correspond to the sections in which the testing and/or calibration procedures are outlined in Chapter 5, Functional Verification, and Chapter 7, Calibration/Adjustment.

SITE: _____ DATE: _____ TECH: _____

MONITOR:(Check)1280 _____ 1281 _____ SERIAL NO: _____

<u>FUNCTION TESTED</u>	<u>SECTION #</u>	<u>FUNCTION OK</u>
<u>Chapter 5, Functional Verification</u>		
Speaker	5.3.1.	_____
Green LED Illumination	5.3.2.	_____
Monitor Power	5.3.3.	_____
TouchScreen Keys	5.3.4.	_____
Display Alignment	5.3.5.	
Raster and Curve Alignment	5.3.5.1.	_____
Colors	5.3.5.2.	_____
Ambient Light Sensor	5.3.6.	_____
Digital I/O	5.3.7.	_____
Monitor Shutdown	5.4.1.	_____
Input and Display	5.4.2.	
Display Agreement with Operating Instructions	5.4.2.5.	_____
Display Interference Free	5.4.2.6.	_____
Display Agreement with Operating Instructions	5.4.2.9.	_____
Display Remains Interference Free	5.4.2.10.	_____
Overall Monitor Function	5.5.	
♥ Symbol	1a.	_____
QRS Volume Keys	1b.	_____
Curve Sweep	2.	_____
Intensity Control	3.	_____
Pacer Detection	4A or 4B.	_____
Memory Backup	5.5.1.	_____

FUNCTIONAL VERIFICATION CHECKLIST (Continued)

<u>FUNCTION TESTED</u>	<u>SECTION #</u>	<u>FUNCTION OK</u>
Lead-Off	5.5.2.	_____
Cable Unplugged	5.5.3.	_____
Temperature	5.5.4.	_____
Cardiac Output	5.5.5.	_____
Alarms	5.5.6.	_____
Advisory	5.5.6.1 or 2.	_____
Serious	5.5.6.3.	_____
Life Threatening	5.5.6.4.	_____
Communication	5.6.	_____
Screen Recording	5.6.1.	_____
Continuous Recording	5.6.2.	_____
Leakage Current	5.7.	_____
<u>Chapter 7. Calibration/Adjustment</u>		
Main Power Supply Voltages	7.1.	_____
+5 V _{DC} Supply	7.1.1.	_____
+15 V _{DC} Supply	7.1.2.	_____
High Voltage Supply	7.2.	_____

SIRECUST 1280/1281 BEDSIDE MONITOR FUNCTIONAL VERIFICATION/PERFORMANCE CHECKLIST

The Section numbers listed below correspond to the sections in which the testing and/or calibration procedures are outlined in Chapter 5, Functional Verification, and Chapter 7, Calibration/Adjustment.

SITE: _____ DATE: _____ TECH: _____

MONITOR: (Check) 1280 _____ 1281 _____ SERIAL NO: _____

<u>FUNCTION TESTED</u>	<u>SECTION #</u>	<u>FUNCTION OK</u>
<u>Chapter 5, Functional Verification</u>		
Speaker	5.3.1.	_____
Green LED Illumination	5.3.2.	_____
Monitor Power	5.3.3.	_____
TouchScreen Keys	5.3.4.	_____
Display Alignment	5.3.5.	_____
Raster and Curve Alignment	5.3.5.1.	_____
Colors	5.3.5.2.	_____
Ambient Light Sensor	5.3.6.	_____
Digital I/O	5.3.7.	_____
Monitor Shutdown	5.4.1.	_____
Input and Display	5.4.2.	_____
Display Agreement with Operating Instructions	5.4.2.5.	_____
Display Interference Free	5.4.2.6.	_____
Display Agreement with Operating Instructions	5.4.2.9.	_____
Display Remains Interference Free	5.4.2.10.	_____
Overall Monitor Function	5.5.	_____
♥ Symbol	1a.	_____
QRS Volume Keys	1b.	_____
Curve Sweep	2.	_____
Intensity Control	3.	_____
Pacer Detection	4A or 4B.	_____
Memory Backup	5.5.1.	_____

FUNCTIONAL VERIFICATION CHECKLIST (Continued)

<u>FUNCTION TESTED</u>	<u>SECTION #</u>	<u>FUNCTION OK</u>
Lead-Off	5.5.2.	_____
Cable Unplugged	5.5.3.	_____
Temperature	5.5.4.	_____
Cardiac Output	5.5.5.	_____
Alarms	5.5.6.	_____
Advisory	5.5.6.1 or 2.	_____
Serious	5.5.6.3.	_____
Life Threatening	5.5.6.4.	_____
Communication	5.6.	_____
Screen Recording	5.6.1.	_____
Continuous Recording	5.6.2.	_____
Leakage Current	5.7.	_____
<u>Chapter 7. Calibration/Adjustment</u>		
Main Power Supply Voltages	7.1.	_____
+5 V _{DC} Supply	7.1.1.	_____
+15 V _{DC} Supply	7.1.2.	_____
High Voltage Supply	7.2.	_____

SIRECUST 1280/1281 BEDSIDE MONITOR FUNCTIONAL VERIFICATION/PERFORMANCE CHECKLIST

The Section numbers listed below correspond to the sections in which the testing and/or calibration procedures are outlined in Chapter 5, Functional Verification, and Chapter 7, Calibration/Adjustment.

SITE: _____ DATE: _____ TECH: _____

MONITOR:(Check)1280 _____ 1281 _____ SERIAL NO: _____

<u>FUNCTION TESTED</u>	<u>SECTION #</u>	<u>FUNCTION OK</u>
<u>Chapter 5. Functional Verification</u>		
Speaker	5.3.1.	_____
Green LED Illumination	5.3.2.	_____
Monitor Power	5.3.3.	_____
TouchScreen Keys	5.3.4.	_____
Display Alignment	5.3.5.	_____
Raster and Curve Alignment	5.3.5.1.	_____
Colors	5.3.5.2.	_____
Ambient Light Sensor	5.3.6.	_____
Digital I/O	5.3.7.	_____
Monitor Shutdown	5.4.1.	_____
Input and Display	5.4.2.	_____
Display Agreement with Operating Instructions	5.4.2.5.	_____
Display Interference Free	5.4.2.6.	_____
Display Agreement with Operating Instructions	5.4.2.9.	_____
Display Remains Interference Free	5.4.2.10.	_____
Overall Monitor Function	5.5.	_____
♥ Symbol	1a.	_____
QRS Volume Keys	1b.	_____
Curve Sweep	2.	_____
Intensity Control	3.	_____
Pacer Detection	4A or 4B.	_____
Memory Backup	5.5.1.	_____

FUNCTIONAL VERIFICATION CHECKLIST (Continued)

<u>FUNCTION TESTED</u>	<u>SECTION #</u>	<u>FUNCTION OK</u>
Lead-Off	5.5.2.	_____
Cable Unplugged	5.5.3.	_____
Temperature	5.5.4.	_____
Cardiac Output	5.5.5.	_____
Alarms	5.5.6.	_____
Advisory	5.5.6.1 or 2.	_____
Serious	5.5.6.3.	_____
Life Threatening	5.5.6.4.	_____
Communication	5.6.	_____
Screen Recording	5.6.1.	_____
Continuous Recording	5.6.2.	_____
Leakage Current	5.7.	_____
<u>Chapter 7, Calibration/Adjustment</u>		
Main Power Supply Voltages	7.1.	_____
+5 V _{DC} Supply	7.1.1.	_____
+15 V _{DC} Supply	7.1.2.	_____
High Voltage Supply	7.2.	_____

**SIRECUST 1280/1281 BEDSIDE MONITOR
FUNCTIONAL VERIFICATION/PERFORMANCE CHECKLIST**

The Section numbers listed below correspond to the sections in which the testing and/or calibration procedures are outlined in Chapter 5, Functional Verification, and Chapter 7, Calibration/Adjustment.

SITE: _____ **DATE:** _____ **TECH:** _____

MONITOR:(Check)1280 _____ **1281** _____ **SERIAL NO:** _____

<u>FUNCTION TESTED</u>	<u>SECTION #</u>	<u>FUNCTION OK</u>
<u>Chapter 5, Functional Verification</u>		
Speaker	5.3.1.	_____
Green LED Illumination	5.3.2.	_____
Monitor Power	5.3.3.	_____
TouchScreen Keys	5.3.4.	_____
Display Alignment	5.3.5.	_____
Raster and Curve Alignment	5.3.5.1.	_____
Colors	5.3.5.2.	_____
Ambient Light Sensor	5.3.6.	_____
Digital I/O	5.3.7.	_____
Monitor Shutdown	5.4.1.	_____
Input and Display	5.4.2.	_____
Display Agreement with Operating Instructions	5.4.2.5.	_____
Display Interference Free	5.4.2.6.	_____
Display Agreement with Operating Instructions	5.4.2.9.	_____
Display Remains Interference Free	5.4.2.10.	_____
Overall Monitor Function	5.5.	_____
♥ Symbol	1a.	_____
QRS Volume Keys	1b.	_____
Curve Sweep	2.	_____
Intensity Control	3.	_____
Pacer Detection	4A or 4B.	_____
Memory Backup	5.5.1.	_____

FUNCTIONAL VERIFICATION CHECKLIST (Continued)

<u>FUNCTION TESTED</u>	<u>SECTION #</u>	<u>FUNCTION OK</u>
Lead-Off	5.5.2.	_____
Cable Unplugged	5.5.3.	_____
Temperature	5.5.4.	_____
Cardiac Output	5.5.5.	_____
Alarms	5.5.6.	
Advisory	5.5.6.1 or 2.	_____
Serious	5.5.6.3.	_____
Life Threatening	5.5.6.4.	_____
Communication	5.6.	
Screen Recording	5.6.1.	_____
Continuous Recording	5.6.2.	_____
Leakage Current	5.7.	_____
<u>Chapter 7. Calibration/Adjustment</u>		
Main Power Supply Voltages	7.1.	
+5 V _{DC} Supply	7.1.1.	_____
+15 V _{DC} Supply	7.1.2.	_____
High Voltage Supply	7.2.	_____

SIRECUST 1280/1281 BEDSIDE MONITOR FUNCTIONAL VERIFICATION/PERFORMANCE CHECKLIST

The Section numbers listed below correspond to the sections in which the testing and/or calibration procedures are outlined in Chapter 5, Functional Verification, and Chapter 7, Calibration/Adjustment.

SITE: _____ DATE: _____ TECH: _____

MONITOR: (Check) 1280 _____ 1281 _____ SERIAL NO: _____

<u>FUNCTION TESTED</u>	<u>SECTION #</u>	<u>FUNCTION OK</u>
<u>Chapter 5, Functional Verification</u>		
Speaker	5.3.1.	_____
Green LED Illumination	5.3.2.	_____
Monitor Power	5.3.3.	_____
TouchScreen Keys	5.3.4.	_____
Display Alignment	5.3.5.	_____
Raster and Curve Alignment	5.3.5.1.	_____
Colors	5.3.5.2.	_____
Ambient Light Sensor	5.3.6.	_____
Digital I/O	5.3.7.	_____
Monitor Shutdown	5.4.1.	_____
Input and Display	5.4.2.	_____
Display Agreement with Operating Instructions	5.4.2.5.	_____
Display Interference Free	5.4.2.6.	_____
Display Agreement with Operating Instructions	5.4.2.9.	_____
Display Remains Interference Free	5.4.2.10.	_____
Overall Monitor Function	5.5.	_____
♥ Symbol	1a.	_____
QRS Volume Keys	1b.	_____
Curve Sweep	2.	_____
Intensity Control	3.	_____
Pacer Detection	4A or 4B.	_____
Memory Backup	5.5.1.	_____

FUNCTIONAL VERIFICATION CHECKLIST (Continued)

<u>FUNCTION TESTED</u>	<u>SECTION #</u>	<u>FUNCTION OK</u>
Lead-Off	5.5.2.	_____
Cable Unplugged	5.5.3.	_____
Temperature	5.5.4.	_____
Cardiac Output	5.5.5.	_____
Alarms	5.5.6.	_____
Advisory	5.5.6.1 or 2.	_____
Serious	5.5.6.3.	_____
Life Threatening	5.5.6.4.	_____
Communication	5.6.	_____
Screen Recording	5.6.1.	_____
Continuous Recording	5.6.2.	_____
Leakage Current	5.7.	_____
<u>Chapter 7. Calibration/Adjustment</u>		
Main Power Supply Voltages	7.1.	_____
+5 V _{DC} Supply	7.1.1.	_____
+15 V _{DC} Supply	7.1.2.	_____
High Voltage Supply	7.2.	_____

SIRECUST 1280/1281 BEDSIDE MONITOR FUNCTIONAL VERIFICATION/PERFORMANCE CHECKLIST

The Section numbers listed below correspond to the sections in which the testing and/or calibration procedures are outlined in Chapter 5, Functional Verification, and Chapter 7, Calibration/Adjustment.

SITE: _____ DATE: _____ TECH: _____

MONITOR:(Check)1280 _____ 1281 _____ SERIAL NO: _____

<u>FUNCTION TESTED</u>	<u>SECTION #</u>	<u>FUNCTION OK</u>
<u>Chapter 5, Functional Verification</u>		
Speaker	5.3.1.	_____
Green LED Illumination	5.3.2.	_____
Monitor Power	5.3.3.	_____
TouchScreen Keys	5.3.4.	_____
Display Alignment	5.3.5.	
Raster and Curve Alignment	5.3.5.1.	_____
Colors	5.3.5.2.	_____
Ambient Light Sensor	5.3.6.	_____
Digital I/O	5.3.7.	_____
Monitor Shutdown	5.4.1.	_____
Input and Display	5.4.2.	
Display Agreement with Operating Instructions	5.4.2.5.	_____
Display Interference Free	5.4.2.6.	_____
Display Agreement with Operating Instructions	5.4.2.9.	_____
Display Remains Interference Free	5.4.2.10.	_____
Overall Monitor Function	5.5.	
♥ Symbol	1a.	_____
QRS Volume Keys	1b.	_____
Curve Sweep	2.	_____
Intensity Control	3.	_____
Pacer Detection	4A or 4B.	_____
Memory Backup	5.5.1.	_____

FUNCTIONAL VERIFICATION CHECKLIST (Continued)

<u>FUNCTION TESTED</u>	<u>SECTION #</u>	<u>FUNCTION OK</u>
Lead-Off	5.5.2.	_____
Cable Unplugged	5.5.3.	_____
Temperature	5.5.4.	_____
Cardiac Output	5.5.5.	_____
Alarms	5.5.6.	
Advisory	5.5.6.1 or 2.	_____
Serious	5.5.6.3.	_____
Life Threatening	5.5.6.4.	_____
Communication	5.6.	
Screen Recording	5.6.1.	_____
Continuous Recording	5.6.2.	_____
Leakage Current	5.7.	_____
<u>Chapter 7. Calibration/Adjustment</u>		
Main Power Supply Voltages	7.1.	
+5 V _{DC} Supply	7.1.1.	_____
+15 V _{DC} Supply	7.1.2.	_____
High Voltage Supply	7.2.	_____

SIEMENS technische Dokumentation geben wir mit dem Ziel heraus, Sie beim Einsatz unserer Produkte zu unterstützen. Bei der Erarbeitung von Form und Inhalt der benötigten Information sind wir jedoch auch auf Ihre Hilfe angewiesen. Bitte teilen Sie uns mit, welche Begriffe oder Beschreibungen weitere Klärung benötigen oder ob diese Veröffentlichung inhaltliche Fehler oder Lücken aufweist.

SIEMENS technical documentation and service information supports you in the use of our products. We would appreciate your suggestions as to how our publications can better serve your needs. Please tell us if you feel certain terms or descriptions need further clarification, or if you found errors or omissions in the content of this publication.

Forward your reply to the Manager of Service Documentation, at the Danvers address listed below.

El servicio de documentación e información técnica de SIEMENS le presta un apoyo incondicional en el empleo de sus productos. Para tal fin, apreciaremos sus sugerencias acerca de como hacer que nuestras publicaciones satisfagan sus necesidades. Por favor díganos si la terminología o las descripciones usadas necesitan clarificaciones o si encuentra errores u omisiones en el contenido de esta publicación.

Dans le souci d'améliorer la qualité de notre documentation technique, nous vous serions reconnaissants de bien vouloir nous faire parvenir vos suggestions sur le contenu et la présentation de ce manuel. N'hésitez pas à nous communiquer toutes erreurs et omissions, et nous faire connaître les termes et descriptions qui auraient besoin d'être énoncés plus clairement pour une meilleure compréhension du texte et de nos produits.

Remita sus sugerencias al Gerente de Documentación de servicio técnico a la dirección de Erlangen (Alemania Occidental) indicada abajo.

Adressez votre courrier à l'attention de Monsieur le Directeur du Service de Documentation, ETD4, à nos bureaux d'Erlangen (R.F.A.), dont vous trouverez l'adresse ci-dessous.

SIEMENS reserves the right to make modifications to equipment without prior notice.

SIEMENS Medical Electronics, Inc.
16 Electronics Avenue
Danvers, MA 01923
USA
Tel: (508) 750-7500
Fax: (508) 777-3398
EPP33/DR. D. KAUPP

SIEMENS Aktiengesellschaft
Bereich Medizinische Technik
Henkestr. 127, D-8520 Erlangen
Deutschland
Tel: (9131) 84-2852
Fax: (9131) 84-2472
ETD41/H. WENING

A91001-M3330-T623-01-7600
E331.E2501.061.21.02.02.
ASK-T623-01-7600
Printed in Germany