

# PLEASE READ

Please check the A page for change information.

Since Air-Shields, Inc. conducts a continuous product improvement program, circuit and component improvements are sometimes incorporated into equipment before they can be incorporated into the printed manuals. When this occurs, changed material is provided on separate sheets at the rear of the manual or under separate cover in the form of a change package. Changed material on each page of text is indicated by a vertical bar on the margin next to the changed material, as shown on the right.



THIS MANUAL CONTAINS PROPRIETARY INFORMATION. REPAIRS AND AUTHORIZED MODIFICATIONS SHOULD BE PERFORMED ONLY BY QUALIFIED SERVICE PERSONNEL TO MAINTAIN YOUR WARRANTY AND TO AVOID CREATING SAFETY HAZARDS. WE CANNOT ASSUME RESPONSIBILITY FOR ANY CONDITIONS AFFECTING THE PROPER OPERATION OF THIS EQUIPMENT WHICH MAY RESULT FROM UNAUTHORIZED REPAIR OR MODIFICATION.

## NOTE ON REPLACEMENT PARTS

Some parts used in your equipment may be different than those which appear in the Parts List of this manual. This sometimes occurs because of difficulty in parts procurement, but does not alter the function of the equipment. Order the part listed in the Parts List.

NOTE: ALSO SEE PAGE 2.

## LIST OF AVAILABLE MODIFICATION KITS

ITEM	DESCRIPTION AND PURPOSE	PART NO.
1	<p>CONTROLLER MAXIMUM AIR TEMPERATURE (38.5°C) RETROFIT KIT.....</p> <p>changes maximum air temperature limit from 38.0 ±0.5°C to 38.5 ±0.5°C and the high air temperature Alarm to 39.5 ±0.5°C displayed temperature. The components supplied in this kit are identified in the applicable parts list (sect.6) by an (*) and reference designation as follows: R20 and R60</p>	68 903 70
2	<p>PROBE FAIL CORRECTION RETROFIT KIT.....</p> <p>Modifies the Controller to ensure that the AIR and SKIN digital displays blank if the air and skin temperature probe opens or shorts. The components supplied in this kit are identified in the applicable parts list (sect.6) by an (*) and reference designation as follows: C3, C9, CR1, and CR6.</p>	68 903 71
3	<p>DISPLAY DRIFT CORRECTION RETROFIT KIT.....</p> <p>Modifies the Controller to ensure the digital displays track to the actual temperature. The components supplied in this kit are identified in the applicable parts list (sect.6) by an (*) and reference designations as follows: C1, C4, C7, C10, CR9, R5, R6, R16, R17, R24, and R34.</p>	68 903 72
4	<p>LONG-STEMMED CASTER RETROFIT KIT (WITH BRAKE).....</p> <p>LONG-STEMMED CASTER RETROFIT KIT (WITHOUT BRAKE).....</p> <p>Reduces possibility of caster falling off of cabinet and reduces wear on caster bushing.</p>	68 901 71 68 901 72

2. (Change 3)

## LIST OF EFFECTIVE PAGES

<u>PAGE NO.</u>	<u>CHANGE NO.</u>	<u>DATE OF ISSUE</u>
Front Cover .....	2	10/84
Inside Front Cover .....	3	6/85
1.....	2	10/84
2 .....	3	6/85
A and B Page .....	3	6/85
i .....	0	12/82
ii .....	2	10/84
iii through vi .....	0	12/82
vii .....	3	6/85
viii .....	0	12/82
1-1 through 1-4 .....	0	12/82
2-1 and 2-2 .....	0	12/82
2-3 .....	1	9/83
2-4 and 2-5 .....	0	12/82
2-6 .....	1	9/83
2-7 and 2-8 .....	0	12/82
2-9 .....	1	9/83
2-10 .....	3	6/85
3-1 .....	2	10/84
3-2 .....	3	6/85
3-3 and 3-4 .....	0	12/82
3-5 .....	2	10/84
3-6 .....	1	9-83
3-7 .....	2	10/84
3-8 .....	1	9/83
3-9 .....	2	10/84
3-10 .....	0	12/82
3-11 .....	2	10/84
3-12 through 3-17 .....	0	12/82
3-18 .....	1	9/83
3-19 .....	0	12/82
3-20 and 3-21 .....	3	6/85
3-22 through 3-32 .....	0	12/82
4-1 through 4-12 .....	0	12/82
5-1 through 5-50 .....	0	12/82
5-51 .....	1	9/83
5-52 .....	0	12/82
6-1 .....	0	12/82
6-2 through 6-4.....	3	6/85
6-5 .....	0	12/82
6-6 through 6-10.....	3	6/85
6-11 .....	0	12/82
6-12 .....	1	9/83
6-13 and 6-14 .....	3	6/85
6-15 .....	2	10/84
6-16 .....	1	9/83
6-17 and 6-18 .....	3	6/85
6-19 .....	2	10/84
6-20 .....	1	9/83

## LIST OF EFFECTIVE PAGES (CONT.)

<u>PAGE NO.</u>	<u>CHANGE NO.</u>	<u>DATE OF ISSUE</u>
6-21 .....	3 .....	6/85
6-22 .....	1 .....	9/83
6-23 .....	3 .....	6/85
6-24 .....	1 .....	9/83
6-25 .....	3 .....	6/85
6-26 .....	2 .....	10/84
6-27 and 6-28 .....	0 .....	12/82
6-29 .....	3 .....	6/85
6-30 .....	0 .....	12/82
6-31 and 6-32 .....	3 .....	6/85
6-33 .....	2 .....	10/84
6-34 .....	1 .....	9/83
6-35 and 6-36 .....	2 .....	10/84
6-37 .....	0 .....	12/82
6-38 .....	1 .....	9/83
6-39 .....	3 .....	6/85
6-40 .....	0 .....	12/82
6-41 and 6-42 .....	3 .....	6/85
6-43 .....	2 .....	10/84
6-44 .....	0 .....	12/82
6-45 .....	3 .....	6/85
6-46 .....	0 .....	12/82
7-1 and 7-2 .....	0 .....	12/82
7-3 and 7-4 .....	1 .....	9/83
7-5 and 7-6 .....	3 .....	6/85
7-7 and 7-8 .....	0 .....	12/82
7-9 and 7-10 .....	1 .....	9/83
7-11 and 7-12 .....	3 .....	6/85
7-13 through 7-22 .....	0 .....	12/82

B. (Change 3)



## TABLE OF CONTENTS

<u>SECTION</u>	<u>PAGE</u>
	TABLE OF DEFINITIONS AND SYMBOLS ..... vii
1	GENERAL INFORMATION
	1.1 Introduction ..... 1-1
	1.2 Description ..... 1-1
	1.3 Accessories ..... 1-1
	1.4 Model Identification/Series Change..... 1-3
2	INSTALLATION
	2.1 General ..... 2-1
	2.2 Assembly ..... 2-1
	2.3 Cleaning ..... 2-2
	2.4 Operational Checkout Procedure ..... 2-3
3	TECHNICAL INFORMATION
	3.1 Specifications ..... 3-1
	3.2 Theory of Operation ..... 3-3
	3.2.1 General ..... 3-3
	3.2.2 System Functional Description ..... 3-3
	3.2.3 Temperature Control ..... 3-5
	3.2.4 Alarms ..... 3-6
	3.3 Detailed Circuit Description ..... 3-8
	3.3.1 General ..... 3-8
	3.3.2 Controller Temperature Control and Alarm Logic (PCB2)..... 3-8
	3.3.3 Controller Displays (PCB1) ..... 3-27
	3.4 Controller Timing Diagrams ..... 3-28
4	PREVENTIVE MAINTENANCE
	4.1 General ..... 4-1
	4.2 Cleaning ..... 4-1
	4.2.1 Disassembly for Cleaning ..... 4-1
	4.2.2 Cleaning ..... 4-6
	4.2.3 Reassembly after Cleaning ..... 4-8
	4.3 Gas Sterilization ..... 4-12
	4.4 Calibration Schedule ..... 4-12
5	SERVICE
	5.1 General ..... 5-1
	5.2 Calibration Procedures ..... 5-1
	5.2.1 General ..... 5-1
	5.2.2 Test Equipment Required ..... 5-1
	5.2.3 PCB2 - Model C100 ..... 5-2
	5.2.4 PCB1 - Model C100 ..... 5-4
	5.2.5 PCB2 - Model C200 ..... 5-4
	5.2.6 PCB1 - Model C200 ..... 5-6

**TABLE OF CONTENTS (CONT.)**

<u>SECTION</u>		<u>PAGE</u>
5	SERVICE (Continued)	
	5.2.7 Leakage Current Tests .....	5-9
	5.2.8 Oxygen Concentration Tests .....	5-9
5.3	Troubleshooting .....	5-10
	5.3.1 General.....	5-10
	5.3.2 Test Equipment Required .....	5-10
	5.3.3 Troubleshooting Procedures .....	5-10
5.4	Removal and Replacement Procedures .....	5-51
	5.4.1 General .....	5-51
	5.4.2 Controller Front Panel .....	5-51
	5.4.3 PCB2 .....	5-51
	5.4.4 PCB1 .....	5-51
	5.4.5 Power and Silence/Reset Switches .....	5-52
	5.4.6 Oxygen Input Valve Filter Cartridge .....	5-52
*6	PARTS LIST	
	6.1 General .....	6-1
7	DIAGRAMS	
	7.1 General .....	7-1

\* ALSO SEE PAGE 2

## LIST OF ILLUSTRATIONS

<u>FIGURE</u>	<u>TITLE</u>	<u>PAGE</u>
1.1	Accessories .....	1-2
2.1	Assembly .....	2-2
2.2	Hood Release Operation .....	2-4
2.3	Access Panel Operation .....	2-4
2.4	Main Deck Retainer .....	2-5
2.5	Mattress Tray Operation .....	2-6
2.6	Access Door Operation .....	2-6
2.7	Mattress Elevator Operation .....	2-7
2.8	Filter Cover Removal .....	2-8
3.1	Air/O <sub>2</sub> Circulation System .....	3-4
3.2	Functional Block Diagram, PCB2 Analog Section .....	3-10
3.3	Functional Block Diagram, Air Flow, High Air Temp. and Probe Failure Alarm Circuitry .....	3-12
3.4	Functional Block Diagram, Set Temp High Alarm Circuitry ....	3-14
3.5	Functional Block Diagram, Set Temp Low Alarm Circuitry ....	3-15
3.6	Variable Triangular Waveform .....	3-19
3.7	Heater Power Control at Full Power .....	3-21
3.8	Functional Block Diagram, Power Up Reset .....	3-22
3.9	Functional Block Diagram, Master Clock .....	3-23
3.10	Functional Block Diagram, One Hour Timer .....	3-24
3.11	Functional Block Diagram, 15 Minute Timer .....	3-26
3.12	Functional Block Diagram, Auto Test .....	3-27
3.13	Functional Block Diagram, PCB1, Controller Displays .....	3-29
3.14	Controller Timing Diagram .....	3-30
4.1	Removal of Controller .....	4-2
4.2	Removal of Inner Wall .....	4-3
4.3	Access Panel Inner Wall Removal .....	4-4
4.4	Removal of Main Deck .....	4-4
4.5	Removal of Air Intake Tube .....	4-5
4.6	Removal of Humidity Fill Pipe Assembly .....	4-7
4.7	Installation of Main Deck and Hood Seat Gasket .....	4-9
4.8	Installation of Iris Entry Port Sleeve .....	4-10
4.9	Installation of Access Door Gasket .....	4-11
5.1	PCB2 (Model C100), Location of Test Points and Adjustments..	5-3
5.2	PCB1 (Model C100), Location of Test Points and Adjustments..	5-5
5.3	PCB2 (Model C200), Location of Test Points and Adjustments..	5-7
5.4	PCB1 (Model C200), Location of Test Points and Adjustments..	5-8
5.5	Oxygen Input Valve Assembly .....	5-52
6.1	Parts Location Diagram, Hood Assembly .....	6-2
6.2	Parts Location Diagram, Access Panel Assembly .....	6-6
6.3	Parts Location Diagram, Shell Assembly and Deck Assembly ...	6-8
6.4	Parts Location Diagram, Model C68 Controller .....	6-12
6.5	Parts Location Diagram, Model C82 Controller .....	6-18
6.6	Parts Location Diagram, Model C68 Controller, Front Panel ..	6-20
6.7	Parts Location Diagram, Model C82 Controller, Front Panel ..	6-22
6.8	Parts Location Diagram, Display Board PCB1 - Model C68 Controller .....	6-24
6.9	Parts Location Diagram, Temperature Control and Alarm Logic PCB2 - Model C68 Controller .....	6-28

**LIST OF ILLUSTRATIONS (CONT.)**

<u>FIGURE</u>	<u>TITLE</u>	<u>PAGE</u>
6.10	Parts Location Diagram, Display Board PCB1- Model C82 Controller .....	6-34
6.11	Parts Location Diagram, Temp. Cont. and Alarm Logic PCB2 - Model C82 Controller .....	6-38
6.12	Parts Location Diagram, Cabinet Stand Assembly .....	6-44
7.1	C68 Controller, Schematic Diagram .....	7-1
7.2	C82 Controller, Schematic Diagram .....	7-9
7.3	C68 Controller, Wiring Diagram .....	7-15
7.4	C82 Controller, Wiring Diagram .....	7-19

## LIST OF TABLES

<u>TABLE</u>	<u>TITLE</u>	<u>PAGE</u>
1.1	Series Change - C68-2 Controller .....	1-3
1.2	Series Change - C82-1 Controller .....	1-3
1.3	Series Change - C100/200-2 Hood and Shell Assy .....	1-3
3.1	Specifications .....	3-1
6.1	Hood Assembly, Parts List .....	6-3
6.2	Access Panel Assy., Parts List .....	6-7
6.3	Shell Assy. and Deck Assy., Parts List .....	6-9
6.4	Model C68 Controller, Parts List .....	6-13
6.5	Model C82 Controller, Parts List .....	6-17
6.6	Model C68 Controller Front Panel, Parts List .....	6-21
6.7	Model C82 Controller Front Panel, Parts List .....	6-23
6.8	PCB1, Model C68 Controller Display Board, Parts List .....	6-25
6.9	PCB2, Model C68 Controller Temp. Contr. and Alarm Logic, Parts List .....	6-29
6.10	PCB1, Model C82 Controller Display Board, Parts List .....	6-35
6.11	PCB2, Model C82 Controller Temp. Control and Alarm Logic, Parts List .....	6-39
6.12	Cabinet Stand Assembly, Parts List .....	6-45

## LIST OF FLOWCHARTS

<u>CHART</u>	<u>TITLE</u>	<u>PAGE</u>
5.1	Overall Checks .....	5-11
5.2	Auto Test Troubleshooting .....	5-19
5.3	Display Troubleshooting .....	5-22
5.4	Set Point Low Alarm Troubleshooting .....	5-23
5.5	Set Point High Alarm Troubleshooting .....	5-26
5.6	One Hour Timer Troubleshooting .....	5-29
5.7	15 Minute Timer Troubleshooting .....	5-30
5.8	Air and Skin* Probe Alarms Troubleshooting .....	5-31
5.9	Air Flow Alarm Troubleshooting .....	5-36
5.10	High Air Temp. Alarm Troubleshooting .....	5-39
5.11	Heater Circuitry Troubleshooting .....	5-42
5.12	38°C Air Temp. Shutdown Troubleshooting .....	5-46
5.13	Power Failure Alarm Troubleshooting .....	5-47
5.14	Oxygen Concentrations .....	5-48
5.15	Insufficient Relative Humidity .....	5-50

\* Model C100 Only.

## TABLE OF DEFINITIONS AND SYMBOLS

### TECHNICAL DEFINITIONS

CONTROL ZONE. Between two planes 10 and 15 cm above the mattress center and parallel to the mattress, measurement points being above the center points of the four quadrants of the mattress.

INCUBATOR TEMPERATURE. Air temperature at a point 10 cm (4 in.) above and centered over the mattress surface.

TEMPERATURE EQUILIBRIUM. The condition reached when the average incubator temperature does not vary more than 0.2°C over a period of one hour.

TEMPERATURE OVERSHOOT. The amount by which incubator temperature exceeds average incubator temperature at temperature equilibrium, resulting from a change in control temperature.

TEMPERATURE RISE TIME. The time required for the incubator temperature to rise 10°C.

TEMPERATURE UNIFORMITY. The amount by which the average temperature at each of four points 10 cm (4 in.) above the mattress surface differs from the average incubator temperature at temperature equilibrium. The four points are the centers of four areas formed by lines that divide the width and length of the mattress surface.

TEMPERATURE VARIABILITY. The variability of the temperature at a fixed point in the incubator above the mattress that will be observed over a one-hour period after TEMPERATURE EQUILIBRIUM has been reached and all accesses remain closed.

### NOTE, IMPORTANT, CAUTION AND WARNING

NOTE. A Note is inserted in text to point out procedures or conditions which may otherwise be misinterpreted or overlooked. A Note may also be used to clarify apparently contradictory or confusing situations.

IMPORTANT: Similar to a Note but used where greater emphasis is required.

CAUTION: A Caution is inserted in text to call attention to a procedure which, if not followed exactly, can lead to damage or destruction of the equipment.

WARNING. A Warning is inserted in text to call attention to dangerous or hazardous conditions inherent to the operation, cleaning, and maintenance of the equipment which may result in personal injury or death of the operator or patient.

## TABLE OF DEFINITIONS AND SYMBOLS (CONT.)

### SYMBOLS



Attention; consult accompanying documents



Type B equipment with an F-type isolated (floating) applied part.



Protective earth (ground)



## **SECTION 1**

### **GENERAL INFORMATION**

#### **1.1 INTRODUCTION**

This manual provides instructions for installation, maintenance, and repair of the Air-Shields® Isolette® Infant Incubator Model C100 and C200; it is intended for use only by trained, qualified service personnel. Instructions for the operator of the Incubators are provided in a separate operator's manual.

#### **1.2 DESCRIPTION**

The forced air circulation system of the Incubator permits stable temperature control, uniform heat distribution, humidification, effective isolation of the infant from airborne contaminants, and control of oxygen concentrations. Accessibility to the infant is provided by an Access Panel, Access Doors, and Iris Entry Ports. When the Access Panel is open, a curtain of warm air flows from beneath the front edge of the mattress toward the top of the Access Panel opening; this air shield minimizes the temperature drop within the hood environment.

On the Model C100, skin or air temperature control is selected by a front panel control. The Model C200 is equipped only for Air Temperature control. Instrumentation includes digital display(s) for temperature, LED's for relative indication of heater output, and a comprehensive visual and audible alarm system which includes an alarm test feature.

#### **1.3 ACCESSORIES**

Accessories available for use with the Incubators are illustrated in Figure 1.1.

C100/200  
GENERAL INFORMATION

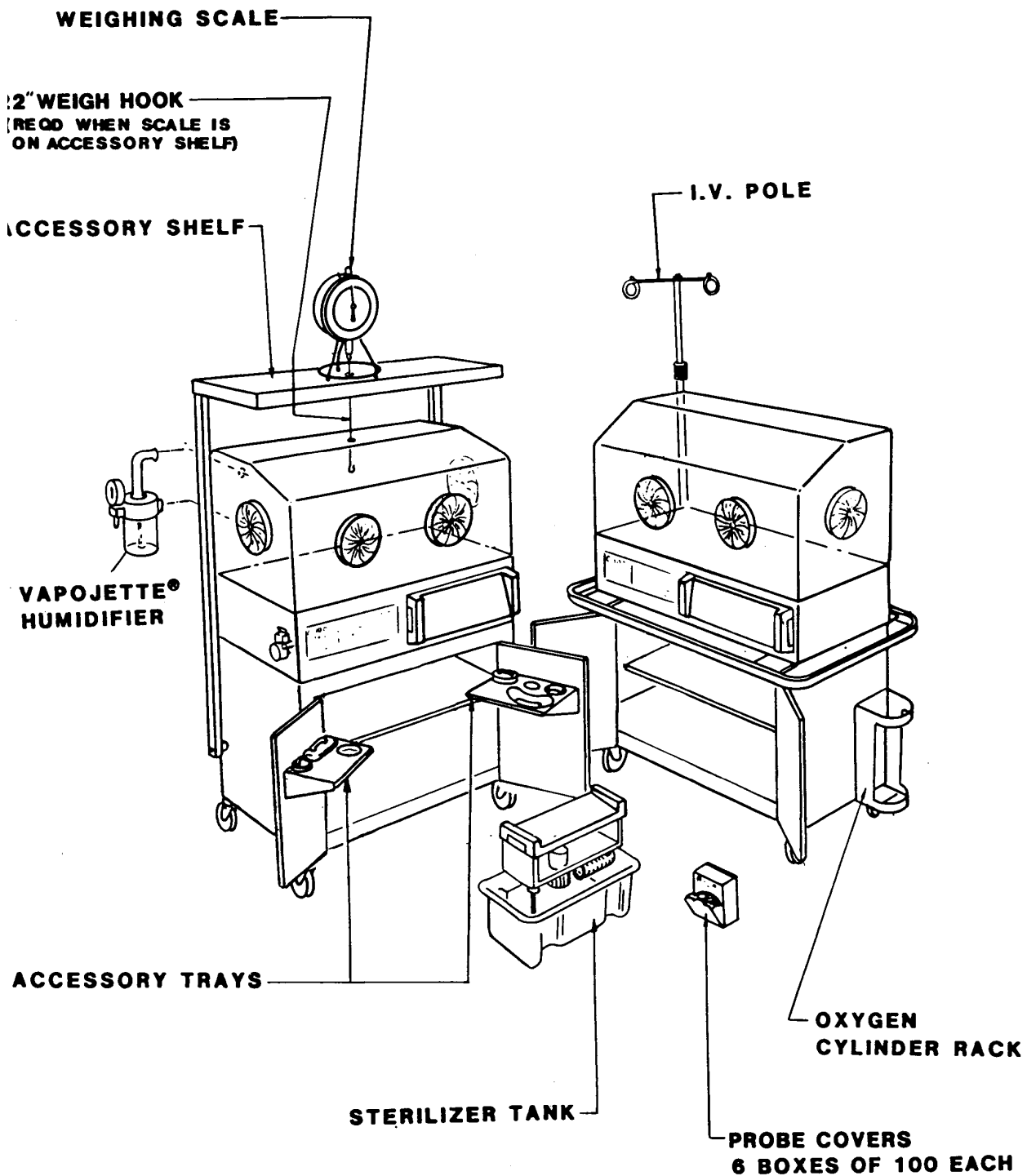

**FIGURE 1.1 ACCESSORIES**

#### 1.4 MODEL IDENTIFICATION/SERIES CHANGE

The Air-Shields® Isolette® Infant Incubator contains two data tags which list model identification and series number. One data tag is located on the side of the Incubator next to the probe and power cord connector panel; this data tag relates to the Hood and Shell Assembly excluding the Controller. The second data tag is located on the top of the Controller Chassis and relates only to the Controller.  
Example:

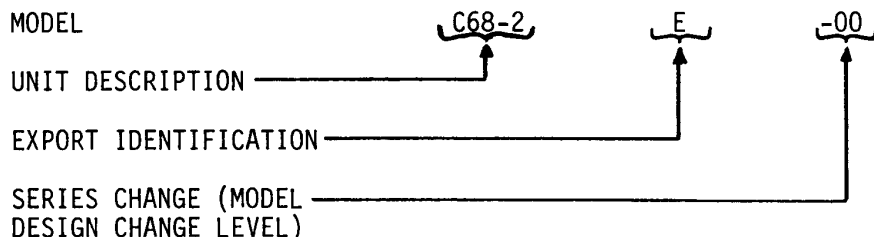

**TABLE 1.1 SERIES CHANGE – C68-2 CONTROLLER**

SERIES NO.	DESCRIPTION OF CHANGE	ITEMS/ASSEMBLIES AFFECTED
00	Original Design	None

**TABLE 1.2 SERIES CHANGE – C82-1 CONTROLLER**

SERIES NO.	DESCRIPTION OF CHANGE	ITEMS/ASSEMBLIES AFFECTED
00	Original Design	None

**TABLE 1.3 SERIES CHANGE – C100/200-2 HOOD AND SHELL ASSEMBLY**

SERIES NO.	DESCRIPTION OF CHANGE	ITEMS/ASSEMBLIES AFFECTED
00	Original Design	None

C100/200  
GENERAL INFORMATION

(This page is intentionally left blank.)

## SECTION 2 INSTALLATION

### 2.1 GENERAL

The Cabinet Stand, the Hood and Base Assembly, and the Guard Rail are shipped in separate cartons. When removing the equipment from the cartons, take care not to scratch or otherwise damage unprotected surfaces. Remove all packing materials from the shell assembly.

### 2.2 ASSEMBLY

Instructions for assembling each major assembly are provided in the shipping carton for that assembly. To assemble the major items (the Cabinet Stand, the Hood and Base Assembly, and the Guard Rail) proceed as follows:

1. Attach the Guard Rail to the underside of the Base Assembly using the 6 bolts and lock nuts supplied (see Figure 2.1).
2. Place the Guard Rail and Base Assembly on the Cabinet Stand as shown in Figure 2.1.

**CAUTION:** Refer to Figure 2.1 for lifting instructions.

3. Secure the Base Assembly to the Cabinet Stand using the clamp on each side of the Cabinet Stand. Clamps may be adjusted by turning the threaded latch into the body of this clamp.

**WARNING:** The Incubator must be attached to the Cabinet Stand using the clamps provided. Failure to do so could result in the Incubator separating from the stand if sufficiently tilted, particularly with the hood open.

4. Install the Hood Assembly on the Base Assembly as shown in Figure 2.1.
5. Assemble the power cord bracket onto the Base Assembly as shown in Figure 2.1.

# C100/200 INSTALLATION

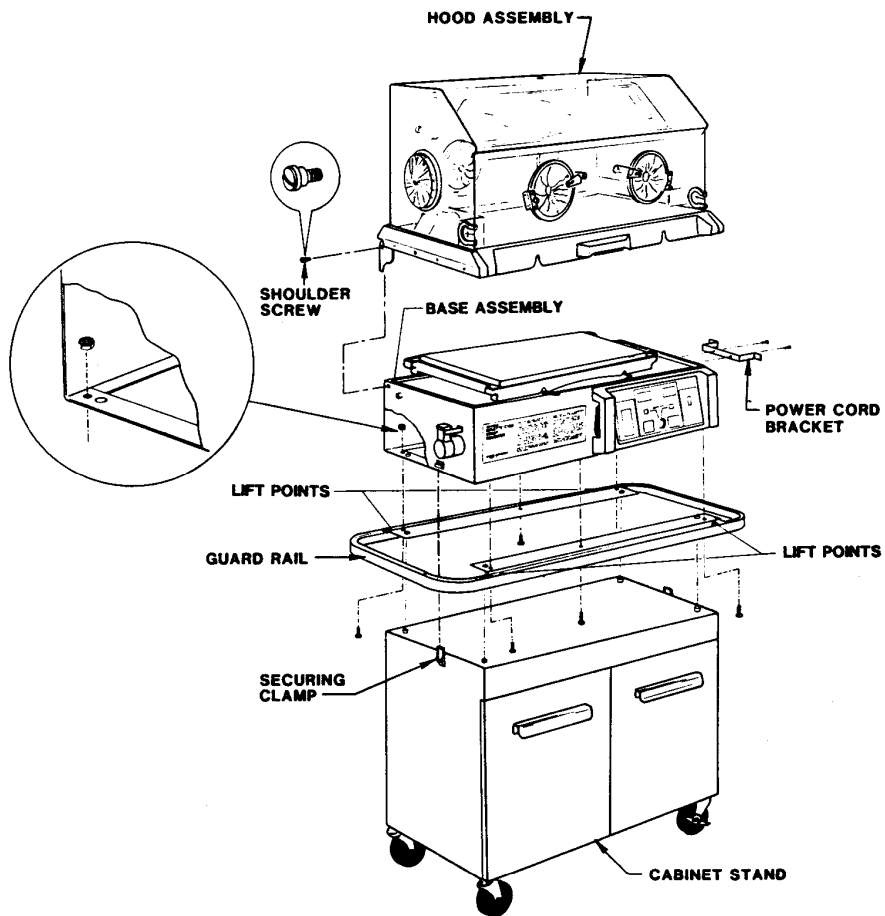

**FIGURE 2.1 ASSEMBLY**

## 2.3 CLEANING

The Incubator should be cleaned as necessary using the procedures described in Section 4 of this manual.

## 2.4 OPERATIONAL CHECKOUT PROCEDURE

The operational checkout should be performed before the Incubator is first placed into use and after any disassembly for cleaning or maintenance.

1. BEFORE CONNECTING THE INCUBATOR to the power source, depress the POWER switch; the power failure alarm should sound, and the POWER FAIL indicator should light. This tests the operation of the power failure alarm circuit and ensures that the rechargeable battery that powers the circuit is in good condition. Depress the POWER switch a second time to silence the alarm.

2. CONNECT THE POWER CORD.

CAUTION: Make sure that the building power source is compatible with the electrical specifications of the Incubator. For proper grounding reliability, connect the power cord only to a properly marked 3-wire hospital grade or hospital use receptacle. Do not use extension cords.

3. ON THE MODEL C100, set the CONTROL MODE switch to the AIR position.
4. DEPRESS THE POWER SWITCH. When on, the switch is illuminated. When initially turned on, the power unit performs a 5-second self test; all alarm lamps light, the audible alarm is pulsed, and each temperature display (two in C100, one in C200) shows 3 eights (88.8). If any function does not occur, the unit requires service.

IMPORTANT:

- This test should be performed on a daily basis.
- The self test tests the lamps displays, and audible alarms, but does not completely simulate a functional failure.

5. ADJUST THE AIR SET TEMP °C THUMBWHEEL SWITCH TO 34.0. All four HEATER lamps should light, indicating full heater output.

NOTE: Allow the unit to operate while continuing the operational checkout.

6. CHECK HOOD HINGE AND LATCH OPERATION for proper positioning. Using the Hood Lift handle, slowly tilt the Hood back until the Hood Latch engages. Close the Hood by releasing the Hood Latch as shown in Figure 2.2.

C100/200  
INSTALLATION

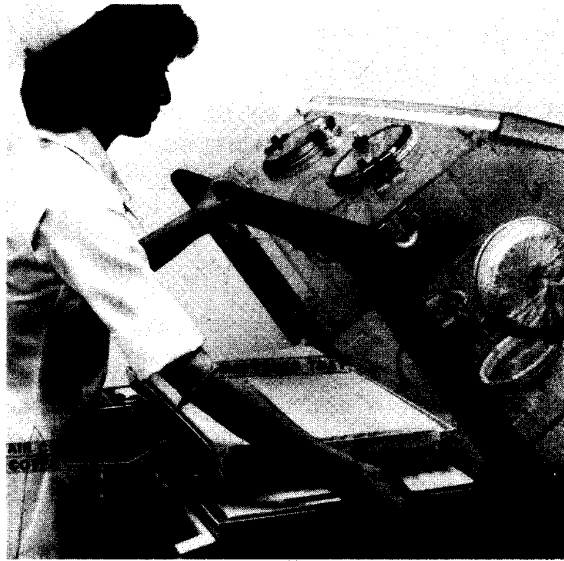

**FIGURE 2.2 HOOD RELEASE OPERATION**

7. CHECK ACCESS PANEL DETENT. Rotate both latch releases inwardly and open the Access Panel as shown in Figure 2.3; the Air Curtain Cover should rise slightly as the Access Panel opens, and the detents should create a noticeable "drag" during initial movement of the panel. Pivot the Access panel to the full open position (hanging straight down).

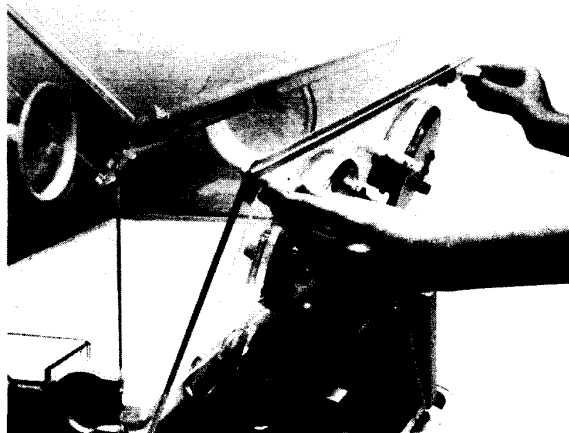

**FIGURE 2.3 ACCESS PANEL OPERATION**



C100/200  
INSTALLATION

8. CHECK AIR CURTAIN COVER. Remove Mattress Tray by lifting straight up to clear the rails on the hood baffles and then withdrawing through the front of the Incubator. Check that the rear curved edge of the Air Curtain Cover is retained by the 1/4" rod between the Mattress Tray rails and that the front edge is about 1" above the Main Deck.

**WARNING:** Do not lift the main deck or touch the heater when performing the following step. The heater can be sufficiently hot to cause burns.

9. CHECK MAIN DECK by pivoting the Air Curtain Cover to the vertical position and checking the Main Deck Retainer; the retainer should be positioned as shown in Figure 2.4. Lower the Air Curtain Cover and reinstall the Mattress Tray.

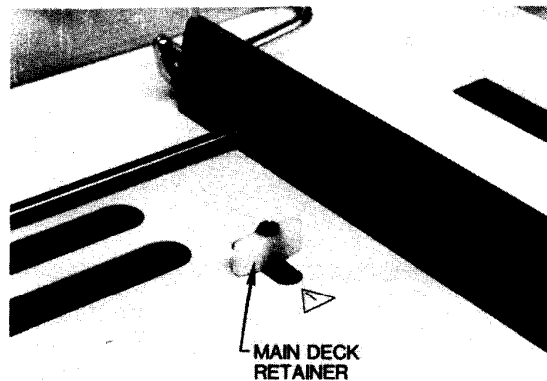

**FIGURE 2.4 MAIN DECK RETAINER**

10. CHECK MATTRESS TRAY by sliding it out to the fully extended position as shown in Figure 2.5. Lean on Mattress Tray; make sure it is properly supported by the rails and baffles to provide a firm infant platform.
11. CHECK ACCESS PANEL LATCHES by closing the Access Panel and rotating both latches until fully engaged. Both latches must be fully engaged to avoid accidental opening of the Access Panel.

C100/200  
INSTALLATION

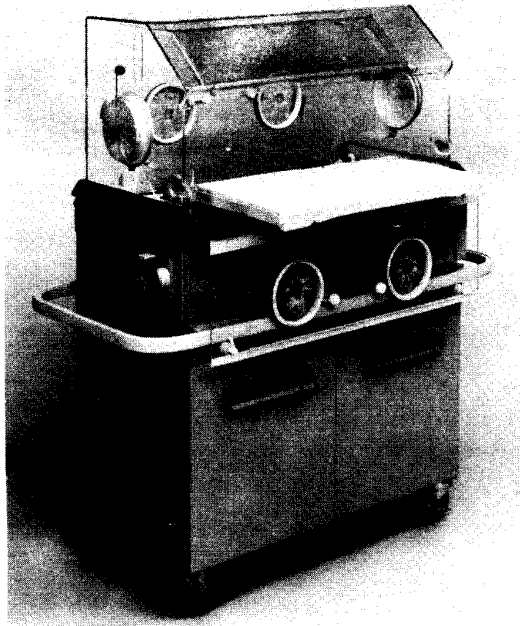

**FIGURE 2.5 MATTRESS TRAY OPERATION**

12. CHECK ELBOW LATCH ACCESS DOORS. Gently press the door release with an elbow, as shown in Figure 2.6. Each Access Door should swing open. Close the doors and check for proper latching.
13. CHECK IRIS ENTRY PORTS. Rotate the outer ring of each Iris Port; the iris should open and close as rotation is continued through 360°.

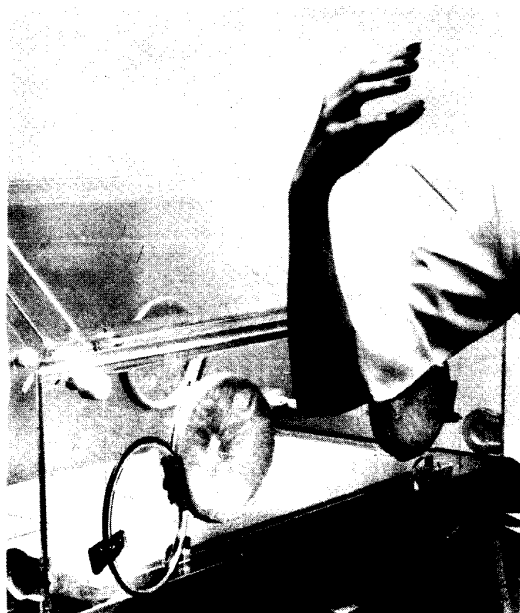
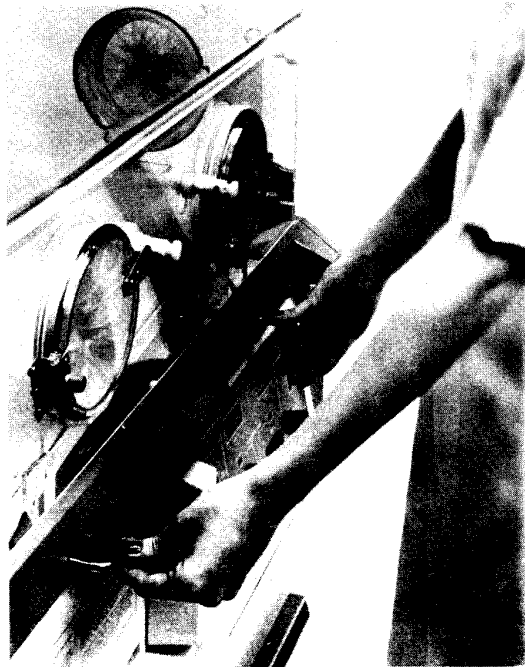

**FIGURE 2.6 ACCESS DOOR OPERATION**

14. CHECK MATTRESS ELEVATORS. Separately operate each Mattress Elevator by rotating handles downward as shown in Figure 2.7.

NOTE:

- These elevator levers are provided to permit the infant to be positioned in Trendelenburg or Fowler position. Do not elevate both ends of the mattress at the same time except for possible use during magnification x-ray procedures. Never leave the infant unattended while both elevators are raised.
- The Hood cannot be opened when either Mattress Elevator is raised.



**FIGURE 2.7 MATTRESS ELEVATOR OPERATION**

C100/200  
INSTALLATION

**WARNING:** A dirty Air Intake Microfilter may affect oxygen concentrations and/or cause Carbon Dioxide buildup. The filter must be checked on a routine basis and changed at least every three months.

15. CHECK THE AIR-INTAKE MICROFILTER. Loosen the two thumbscrews of the Air-Intake Filter Cover and remove the cover as shown in Figure 2.8. Inspect the microfilter; if visibly dirty it should be replaced. Refer to paragraph 4.2.3 for additional instructions.



**FIGURE 2.8 FILTER COVER REMOVAL**

16. CHECK THE OXYGEN INPUT VALVE FILTER. The Oxygen Input Valve Filter Cartridge should be checked once every four months and replaced if the ends are gray or black. Refer to paragraph 5.4.8 for instructions on disassembly of the Oxygen Input Valve.
17. CHECK AIR/OXYGEN SYSTEM by introducing a carefully measured 8 LPM of oxygen, then monitoring levels within hood to verify that they reach the predicted level as indicated on the Filter Cover Assembly.

18. CHECK AIR TEMPERATURE MODE OF OPERATION. Place calibrated test thermometer 4 inches above center mattress. With all access openings closed, allow the Incubator to warm up to the thumbwheel setting (34.0); it should take approximately one hour or less. While the unit is warming up, suspend the auxiliary probe through the hole in the top of the Incubator Hood and position the patient probe\* in the center of the mattress surface; do not connect the probe plugs to the receptacles. When the AIR TEMP °C Display has stabilized, the number of HEATER Indicator lamps illuminated will typically be reduced to no more than two. Check that the digital display remains within 0.5°C of set temp for 15 minutes after stabilization. The test thermometer should read within 1.0°C of the displayed temperature.
19. CHECK AIR SET TEMP. ALARM by setting the AIR SET TEMP °C thumbwheel first to 32.0°C, then to 38.0°C. An audible and visual alarm should activate at each setting after a 9 to 18 second delay, and cancel when the setting is returned to the display reading.
20. CHECK AUXILIARY PROBE. Insert the Auxiliary Probe connector into the AUXILIARY AIR PROBE receptacle. Set the AIR SET TEMP °C thumbwheel to 34.0°C. When AIR TEMP °C Display has stabilized, the number of HEATER Indicator Lamps illuminated will typically be reduced to no more than two. Check that the digital display remains within 1.0°C of set temp for 15 minutes after stabilization.
- 21.\* CHECK SKIN TEMPERATURE MODE OF OPERATION. Connect the Patient Probe plug to the PATIENT PROBE Receptacle and set the SKIN SET TEMP °C thumbwheel to 36.0°C. Set the CONTROL MODE Switch to the SKIN position. If the SET TEMP alarm actuates, depress the Alarm SILENCE/RESET Button. Allow the Incubator temperature to stabilize at 36°C.
- 22.\* CHECK SKIN SET TEMP ALARM. Leave the CONTROL MODE Switch in the SKIN position and set the SKIN SET TEMP°C thumbwheel to 37.5°C, then to 34.5°C. An audible and visual alarm should activate at each setting and cancel when the setting is returned to the display reading.
- 23.\* CHECK SKIN PROBE ALARM. Leave the CONTROL MODE Switch in the SKIN position and disconnect the Patient Probe from the receptacle. The audible and visual alarms should activate, the SKIN TEMP °C digital display should blank, and the HEATER Indicator Lamps should all go off. When the Skin Probe is reconnected, the Incubator should return to normal operation.

\* Model C100 only.

C100/200  
INSTALLATION

**WARNING:** The Controller heater can be sufficiently hot to cause burns; avoid removing the Controller or touching the heater until the unit has been switched off for at least 45 minutes.

24. **CHECK AIR FLOW ALARM.** Set the POWER switch to OFF. Remove the Controller (Figure 4.1) from the Incubator. Remove the fan impeller from the fan motor shaft, and reinstall the Controller in the Incubator. Set the POWER switch to ON and wait for the end of the Auto-Test cycle (5 seconds). Within 5 minutes, the AIR FLOW indicator should flash, a pulsating audible alarm should sound, and all HEATER lights should go out. Reinstall the fan impeller and restore the Incubator to normal operating condition before proceeding.
25. **CHECK MAXIMUM AIR TEMPERATURE.** On the Model C100, position the probe end of the Patient Probe outside the Incubator (leave the CONTROL MODE Switch in the SKIN position). On the Model C200, set the thumbwheel switches to 39.9°C. Allow the Incubator to heat. If the SET TEMP alarm actuates, depress the Alarm SILENCE/RESET Button.

The Incubator should not heat above  $38.5 \pm 0.5^\circ\text{C}$ , as indicated on the AIR TEMP °C display. The test thermometer located at center mattress should read less than  $40^\circ\text{C}$ .

26. **CHECK HIGH TEMPERATURE ALARM.** Position probe end of auxiliary probe outside the Incubator, and a calibrated thermometer 4-inches above the center of the mattress. If the SET TEMP alarm actuates, depress the Alarm SILENCE/RESET Button. When the HIGH TEMPERATURE Alarm actuates, disconnect the auxiliary probe; the AIR TEMP °C display and the calibrated thermometer should read  $39.5 \pm 1.0^\circ\text{C}$  (see note below). The test thermometer located at center mattress should read within  $1.3^\circ\text{C}$  of the displayed temperature.
27. **CHECKOUT IS COMPLETE.** Disconnect and store the Auxiliary and Patient\* Probes. If the Incubator is to be used, set the CONTROL MODE Switch\* to the AIR position and leave the Incubator running until ready for use. If it is not going to be used it may be shut off.

\* Model C100 only.

NOTE:  $39.5 \pm 0.5^\circ\text{C}$  in current production Incubators and Incubators which have been retrofitted for Air Temperature Limit of  $38.5^\circ\text{C}$ . See Tables 6.9 and 6.11 for details relating to component changes.

### SECTION 3 TECHNICAL INFORMATION

#### 3.1 SPECIFICATIONS

Specifications for Incubator Models C100 and C200 are provided in Table 3.1. All specifications are subject to change without notice.

**TABLE 3.1 SPECIFICATIONS**

#### CONTROLLER POWER REQUIREMENTS:

Model C68-2	.....	110/120V ~, 50/60 Hz, 390/450W
Model C68-2E	.....	220/240V ~, 50/60 Hz, 390/450W
	.....	100V ~, 50/60 Hz, 390/450W
Model C82-1	.....	110/120V ~, 50/60 Hz, 390/450W
Model C82-1E	.....	220/240V ~, 50/60 Hz, 390/450W
	.....	100V ~, 50/60 Hz, 390/450W

CHASSIS LEAKAGE CURRENT ..... 100 uA or less.

#### ALARMS:

Air-Flow	.....	Actuated by fan failure.
Probe	.....	Actuated if Air or Skin* Temperature Probe or High Temperature Probe is electrically open, shorted, or disconnected, or if Air Flow Probe is shorted.
High Temperature	.....	Actuates if Air Temperature sensed below deck rises above $39.5 \pm 1^\circ\text{C}$ . (See Note below).
Set Temperature (SET TEMP)	.....	Actuates if Skin* or Air Temperature fluctuates from set temperature as follows: Skin Temperature* $+1.0 \pm 0.3^\circ\text{C}$ $-1.0 \pm 0.3^\circ\text{C}$ Air Temperature $+1.5 \pm 0.5^\circ\text{C}$ $-3.0 \pm 0.5^\circ\text{C}$
Power Failure Alarm (POWER FAIL)	.....	An alarm which is actuated if primary power to the incubator fails or the power cord is accidentally disconnected from the wall receptacle or the Incubator.

\* Model C100 Only.

**NOTE:**  $39.5 \pm 0.5^\circ\text{C}$  in current production Incubators and Incubators which have been retrofitted for Air Temperature Limit of  $38.5^\circ\text{C}$ . See Tables 6.9 and 6.11 for details relating to component changes.

TABLE 3.1 SPECIFICATIONS (CONT.)

ALARM SILENCE/RESET Switch	
Silence .....	Silences the set temp audible alarm for 12 to 15 minutes; alarm silence is automatically over-ridden if a subsequent alarm occurs within the period of silence.
Reset .....	Cancels High Air Temp., Air Flow or Probe Alarm if alarm condition no longer exists.
TEMPERATURE CONTROL RANGES:	
Air Temperature Mode .....	20°C to 38°C.± 1.0°C.***
Skin Temperature Mode* .....	34 to 37.9°C.
TEMPERATURE RISE TIME** .....	45 minutes.
TEMPERATURE VARIABILITY** .....	0.2°C.
TEMPERATURE OVERSHOOT** .....	0.5°C maximum.
TEMPERATURE UNIFORMITY** .....	1°C.
CORRELATION OF INDICATED AIR TEMPERATURE TO ACTUAL INCUBATOR TEMPERATURE** (after Temperature Equilibrium** is reached) .....	
± 1°C.	
CORRELATION OF INDICATED AIR TEMPERATURE TO SET TEMP. (after Temperature Equilibrium** is reached):	
Air .....	± 0.5°C of set temperature up to 38°C.***
Skin* .....	± 0.3°C of set temperature up to 37.9°C.
OXYGEN CONCENTRATION RANGE .....	20.9 to 70%.
HUMIDITY .....	Typically between 50 and 60% with water in humidity reservoir.
NOMINAL DIMENSIONS:	
Height .....	134 cm (52-3/4").
Depth .....	56 cm (22").
Width .....	116 cm (45.7").
NOMINAL WEIGHT .....	76 Kg (168 lbs.)
NOISE LEVEL WITHIN HOOD ENVIRONMENT .....	
60 dBA maximum with 50 dBA or less ambient.	
AIR VELOCITY OVER MATTRESS .....	
Does not exceed 10 cm/sec (20ft/min) within Control Zone**.	

\* Model C100 only.

\*\* Refer to Table of Definitions and Symbols.

\*\*\* 38.5°C ± 0.5°C in current production Incubators and Incubators that have been retrofitted for Air Temperature Limit of 38.5°C.



## 3.2 THEORY OF OPERATION

### 3.2.1 GENERAL

This section contains a system functional description for Isolette Infant Incubators Model C100 and C200 and detailed theory of operation for the Controllers.

### 3.2.2 SYSTEM FUNCTIONAL DESCRIPTION

The control of temperature, humidity, and oxygen concentration is achieved by means of the forced air circulation system as shown in Figure 3.1. A controlled amount of room air (approximately 35 lpm) is drawn through the air/oxygen intake filter by means of the motor driven impeller on the control unit. Supplemental oxygen, which is introduced through the Oxygen Input Valve on the filter cover, displaces a portion of room air to maintain the total gas intake (including oxygen) at 35 lpm. Since the amount of room air is controlled by the impeller/filter characteristics and the amount of oxygen is controlled by the flowmeter setting, predictable oxygen concentration within the incubator can be attained. When oxygen flow exceeds 8 lpm, a valve within the oxygen inlet housing is activated to restrict air intake so that higher oxygen concentrations can be achieved without excessive oxygen flow. At 12 lpm maximum air intake restriction is achieved.

In addition to drawing fresh, filtered air into the Incubator, the impeller provides for the internal recirculation at a much greater flow than that of the fresh gas inflow. The total flow of fresh plus recirculated air is directed past the air flow sensor and around the heater with a predetermined portion being directed over the humidity reservoir for humidification. When the Access Panel of the Hood is closed, the Air Curtain Cover is closed and all the air enters the infant compartment up through the slot at one end of the main deck as shown in Figure 3.1. After circulating within the infant compartment, the air is then recirculated down through the slot in the other end of the main deck, past the temperature sensing probe, which encapsulates the air temperature control thermistor and a high air temperature alarm thermistor, and back to the impeller. When the Access Panel of the Hood is open, the Air Curtain Cover is raised permitting a portion of the air to flow upward past the opening (Figure 3.1) creating a warm air shield which minimizes the drop in Incubator temperature.

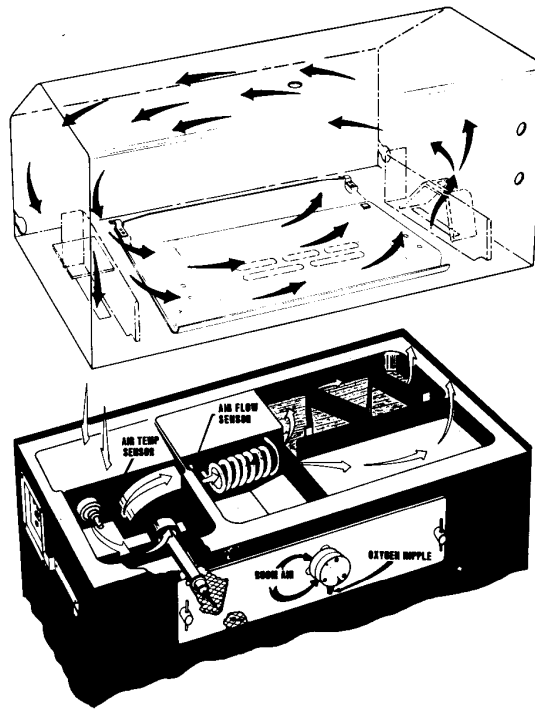

AIR CIRCULATION WITH INCUBATOR DOOR CLOSED

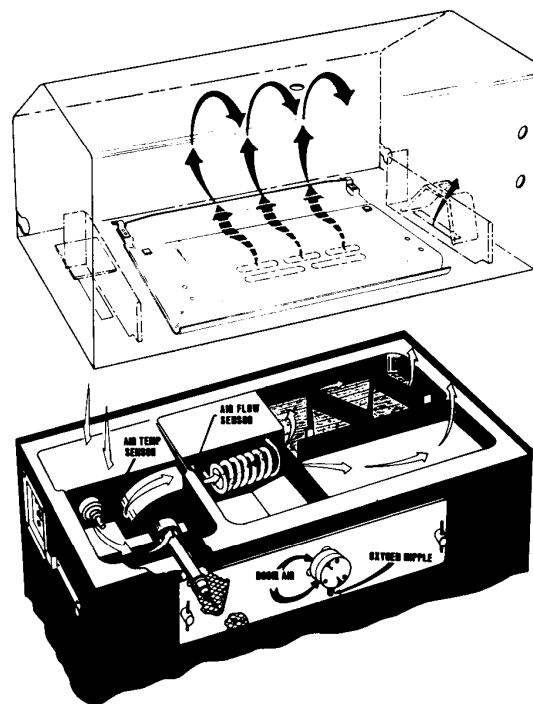

AIR CIRCULATION WITH INCUBATOR DOOR OPEN

FIGURE 3.1 AIR/O<sub>2</sub> CIRCULATION SYSTEM

### 3.2.3 TEMPERATURE CONTROL

In the Model C100, Incubator temperature is regulated using either Incubator air or infant's skin temperature as the controlling parameter; the desired mode is selected by a front panel switch. The Model C200 provides only air temperature control. In either mode of operation, the heater output is proportional to the amount of heat required to maintain the desired temperature, and the relative amount of heat being provided is indicated by the number of lit HEATER output lamps on the front panel. Changes in the number of lamps illuminated indicate the amount of power required to maintain a given temperature. During skin temperature control, Model C100 provides an indication of the degree of the infant's dependency upon the temperature of its environment to maintain body temperature. Each mode of operation is described below.

AIR TEMPERATURE MODE (MODELS C100 AND C200). In this mode of operation, the air temperature can be maintained from 20 to 38°C as selected by the AIR SET TEMP °C thumbwheel switch on the front panel. The Incubator temperature is monitored by a probe located below deck and compared with the thumbwheel settings. The information from this probe is supplied to the heater control circuitry which proportions the heater output to maintain the thumbwheel setting. Actual air temperature is displayed on the Air Temperature Display. A second sensor within the air temperature probe serves as a backup to limit the temperature sensed below deck to between 39.0 and 40.0°C; at this temperature an alarm is activated and the heater is shut off.

If desired, an auxiliary probe can be used to monitor and control the Incubator air temperature. This probe is suspended above the mattress through the weighing scale hole and plugged into a special receptacle on the side of the Incubator. When plugged in, the primary air temperature probe is disconnected, but the backup sensor within the primary temperature probe remains connected. Thus, the auxiliary probe becomes the controlling element for the air temperature.

In the Air Temperature mode of operation, the infant's temperature will be a function of the air temperature and the infant's ability to establish and maintain its own temperature. A small infant, or one with underdeveloped homeostatic control, may not be able to maintain a stable temperature at the optimum level.

C100/200  
TECHNICAL INFORMATION

SKIN TEMPERATURE MODE. (MODEL C100). In this mode of operation, the infant's skin temperature can be maintained at a temperature from 34 to 37.9°C as selected by the SKIN SET TEMP °C thumbwheel switch on the front panel. A temperature sensing probe is attached directly to the infant's skin; the information from the probe is supplied to the heater control circuitry which proportions the heater output to maintain the skin set temperature. The air temperature set temp does not control air temperature while in the skin temperature mode, but actual air temperature is still displayed. The air temperature probe (or a properly installed auxiliary probe) still limits the air temperature to a maximum of 38.5°C. If the CONTROL MODE Switch is set to the Air Temperature mode while the skin probe remains connected, the Skin Temperature display will continue to display actual skin temperature, but will not control. If the probe is disconnected from its receptacle at any time (Skin mode of operation), the Skin display blanks and an alarm is activated. The backup sensor within the Air Temperature probe remains in the circuit to limit maximum air temperature to 40°C.

### 3.2.4 ALARMS

The Incubator is equipped with a system of alarms and temperature protection devices. Alarm indications are provided for power failure, inadequate air flow, probe failure, high temperature, and variation from set temp. Each time the unit is turned on, the unit is automatically stepped through an alarm check sequence to verify proper alarm function. After the automatic alarm check is made, the low set temp alarm is disabled for about 60 minutes, or until the temperature reaches set temp whichever occurs first. Each of these alarms is described below.

AIR FLOW ALARM (MODELS C100 AND C200). A sensor located below deck in the normal air path of the fan controls this alarm. If air flow is obstructed (due to a fan failure or total air circulation failure), the temperature of the self-heated sensor rises causing the AIR FLOW alarm on the front panel to flash and produces a pulsating audible tone. This alarm is non self-resetting and cannot be cancelled by the Alarm SILENCE/RESET Button until the alarm condition is corrected.

HIGH TEMPERATURE ALARM (MODELS C100 AND C200). A second sensor within the Air Temperature Probe sounds this alarm if the sensed temperature exceeds  $39.5 \pm 1^\circ\text{C}^*$ . A high temperature alarm is indicated by a flashing light and a continuous audible tone. This alarm is non self-resetting and cannot be cancelled by the Alarm SILENCE/RESET Button until the alarm condition is corrected.

\*  $39.5 \pm 0.5^\circ\text{C}$  in current production Incubators and Incubators which have been retrofitted for Air Temperature Limit of 38.5°C. See Tables 6.9 and 6.11 for details relating to component changes.

PROBE ALARM. Circuitry is provided to monitor air, skin\*, and high temperature sensors for shorted, open or disconnected conditions.

In the Model C100 Incubator, an indicator light flashes and an audible alarm sounds to indicate a defective air temperature, skin temperature, auxiliary or shorted air flow sensor. The probe alarm is also actuated if the skin temperature probe is disconnected while in skin mode.

The Model C200 Incubator is equipped only for air control; therefore, no skin probe alarm is provided. The probe alarm is actuated to indicate a defective air temperature, auxiliary or shorted air flow sensor.

In either Incubator, if a probe shorts, it will appear as a high set temp violation, and the set temp alarm will light. This alarm is non self-resetting and cannot be cancelled by the Alarm SILENCE/RESET Button until the alarm condition is corrected. If a probe alarm occurs simultaneously with a set temp alarm, a shorted probe is probably the true cause of the alarm, since a shorted probe will appear as a high temperature condition.

SET TEMP ALARM. The Set Temp alarm is actuated if skin\* or air temperature fluctuates from set temperature as follows:

- \*Skin Temperature       $+1 \pm 0.3^{\circ}\text{C}$   
    $-1 \pm 0.3^{\circ}\text{C}$
- Air Temperature         $+1.5 \pm 0.5^{\circ}\text{C}$   
    $-3.0 \pm 0.5^{\circ}\text{C}$

A temperature below the set temp is indicated by a flashing light, a pulsating audible tone, and a low temperature reading; a temperature above the set temp is indicated by a flashing light, a continuous audible tone, and a high temperature reading. If a set temp alarm occurs simultaneously with a probe alarm, a shorted probe is probably the true cause of the alarm, since a shorted probe will appear as a high temperature condition.

The set temp alarm is self-resetting; that is, if the alarm condition is corrected, the audible alarm is automatically silenced and the light is turned off.

The audible set temp alarm can be silenced by depressing the SILENCE/RESET Button; the activation of other audible and visual alarms will not be affected by use of the 15 minute audible alarm silence. When silenced, the alarm lamp will remain on until the alarm condition is corrected. If the alarm condition is not corrected within 15 minutes, the audible alarm will be reactivated.

\* Model C100 only.

POWER FAILURE ALARM (MODELS C100 AND C200). If primary power to the Incubator is interrupted for any reason, including a disconnected power cord, an audible alarm is activated and an alarm lamp lights. This alarm can be deactivated only by restoring the primary power or setting the Incubator POWER Switch off.

### 3.3 DETAILED CIRCUIT DESCRIPTION

#### 3.3.1 GENERAL

This paragraph provides detailed circuit descriptions of the Controllers. An overall functional description is provided elsewhere in this section.

All electronics, except the temperature probes, air circulation fan, heater connectors, etc., is contained on two printed circuit boards. A detailed functional description of these printed circuit boards and their relationship with the probes, air circulation fan, heater, connectors, etc., are provided in the following paragraphs.

#### 3.3.2 CONTROLLER TEMPERATURE CONTROL AND ALARM LOGIC (PCB2)

PCB2 consists of an analog section and digital section. The analog section (Figure 3.2) monitors the probes, sensors, and set temp switches; it also contains the power supply, temperature control, heater control, and power failure alarm circuitry.

The digital section contains the master clock, auto test, 15 minute silence, and one hour inhibit circuitry. In addition, it contains the 9 to 18 second delay circuitry and alarm latches.

AIR DATA CIRCUITRY (Figs. 3.3 and 7.1 or 7.2) The function of the Air Data Circuitry is to monitor either the Air Temperature Probe RT1-A or the Auxiliary Probe and Air Set Temp Switches and provide an error signal to the Temperature Control circuitry.

The Air Temperature thermistor RT1-A is connected across a linearization network consisting of R34, R36, R37, and R38. When the Auxiliary Probe is connected to jack J20, RT1-A is disconnected from the network and the Auxiliary Probe is connected to the network. The output of the linearization network is applied to differential amplifier AR4-1. This amplifier has a gain of 15 and has an output of 200 mV/°C. The output of AR4-1 is applied to the Air Limit Circuitry and the junction of R44 and R45, the air temperature summing point. The other input to this summing point is from AR4-2, the set temp amplifier. AR4-2 is connected to the Air Temperature set temp switches and is a current-to-voltage amplifier whose output is -500 mV/°C and is also applied to the junction of R44 and R45. The

summed voltage, which represents the difference between the Incubator air temperature and set temp temperature, is applied to AR6-1, an error amplifier whose output is  $\pm 5.0$  volts per  $\pm 1.5^\circ\text{C}$  difference between the Incubator air temperature and set temp temperature. The output of AR6-1 is applied to the Temperature Control circuitry via S1-B\* and the TEMP Fail Circuitry via R77.

\*SKIN DATA CIRCUITRY (Figs. 3.2 and 7.1) The function of the Skin Data Circuitry is to monitor the Skin Probe RT2 and Skin Set Temp switches and provide an error signal to the Temperature Control circuitry. The Skin Temperature Probe is connected across a linearization network consisting of R50 through R53. The output of the linearization network is applied to differential amplifier AR5-1. This amplifier has a gain of 15 and has an output of  $200\text{ mV}/^\circ\text{C}$ . The output of AR5-1 is applied to the Probe Fail Circuitry via S1-D. In addition, the output is applied to the junction of R47 and R55, the skin temperature summing point. The other input to this summing point is from AR5-2, the set temp amplifier. AR5-2 is connected to the Skin Temperature set temp switches, and is a current- to-voltage amplifier whose output is  $-500\text{ mV}/^\circ\text{C}$ . The summed voltage which represents the difference between the infant's skin temperature and the set temp switches is applied to AR6-4, an error amplifier, whose output is  $\pm 5.0$  volts per  $\pm 1.0^\circ\text{C}$  difference between skin temperature and set temp temperature. The output of AR6-4 is applied to the Temperature Control Circuitry via S1-B and the Temp Fail Circuitry via S1-C.

PROBE FAIL ALARM CIRCUITRY The Probe Fail Alarm Circuitry is split between the analog and digital portions of PCB2. The following discussion is divided accordingly.

ANALOG (Figs. 3.2, and 7.1 or 7.2) The output of the Air Data (AR4-1) or Skin Data (AR5-1)\* circuitry is applied to the Probe Fail circuitry across CONTROL MODE Switch S1-D\*. When a temperature sensing thermistor shorts, the output of the differential amplifier (AR4-1 air, AR5-1 skin)\* goes to approximately +10 volts (saturation) which causes AR9-1 pin 13 to go low and activate the probe failure alarm circuitry. A shorted high temperature and shorted air flow probe will also cause TP30 to go low and activate the probe failure alarm circuit.

\* Model C100 only.

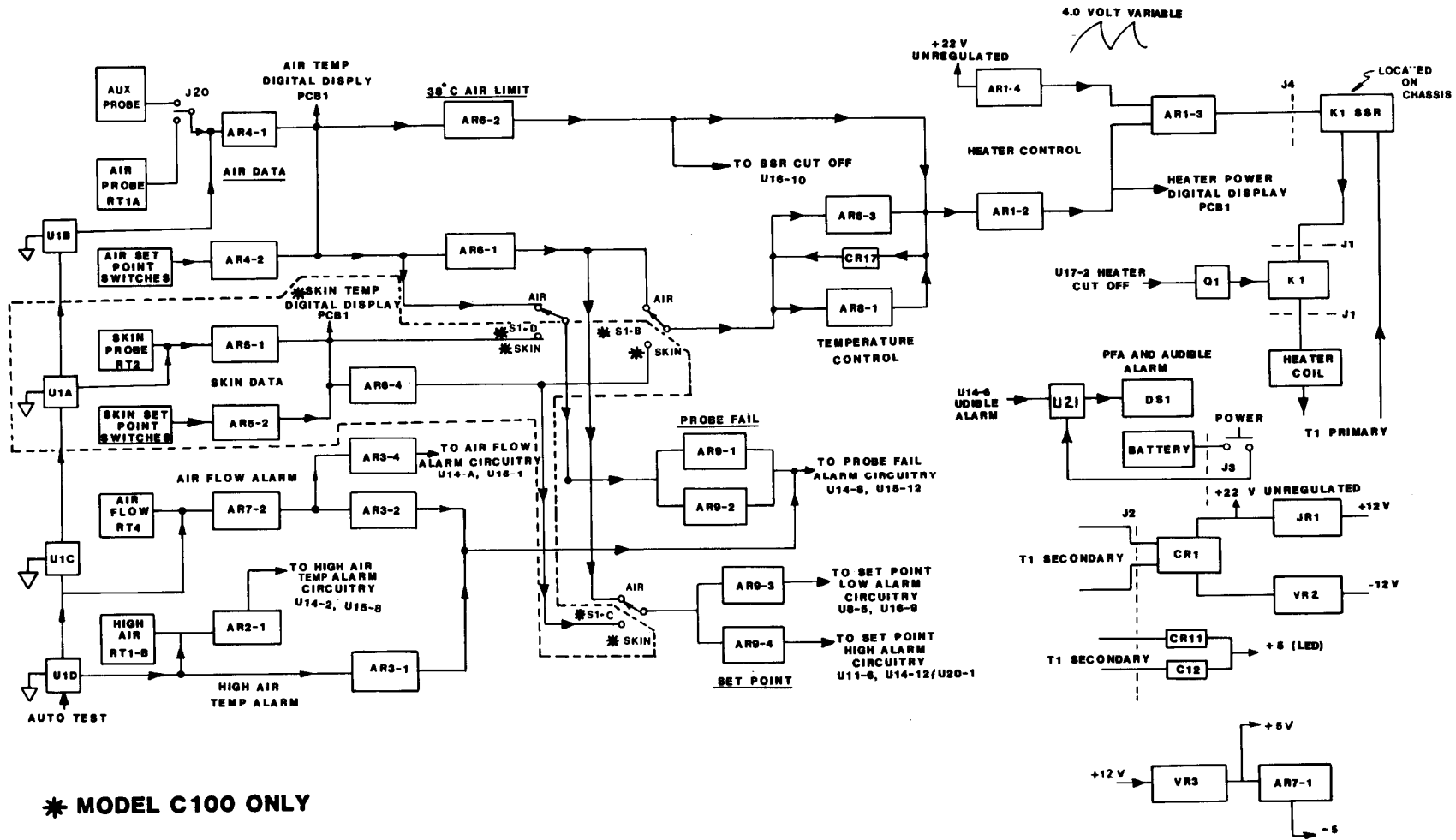

C100/200  
TECHNICAL INFORMATION

FIGURE 3.2 FUNCTIONAL BLOCK DIAGRAM, PCB2 ANALOG SECTION



When a temperature sensing thermistor opens, the output of the differential amplifier (AR4-1 air, AR5-1 skin\*) goes to -6.5 volts and causes AR9-2 pin 14 to go low and activate the probe failure alarm circuitry. An open high temperature probe will activate the probe failure alarm circuitry.

DIGITAL (Figs. 3.3, 7.1 or 7.2) When a Probe Failure occurs, a logic low is applied to U14-A (pin 8). This low causes U16-B (pin 4) to go low and start the 9 to 18 second Delay Timer U5-A and U5-B. After the timer times out, U5-B (pin 13) goes low and is applied to U15-D (pin 13), U15-C (pin 9), and U15-A (pin 2).

The low at U14-A (pin 8) is also applied to U15-3 (pin 12) thus determining that the alarm is a Probe Failure Alarm. U15-D (pin 11) goes high and will set latch U19-B (pin 1) high at the next clock pulse. The high at U19-B (pin 1) is applied to U18-A (pin 1) whose other input is the flashing signal from the Alarm Flash Circuitry U16-A (pin 2). The output of U18-A (pin 3) then flashes the PROBE lamp on the front panel.

The output of U19-B (pin 1) is also applied to U20-C (pin 11) which will pulse the audible alarm on and off via U11-A and U14-B. If the Probe Failure is related to either the air or skin\* thermistor, the alarm will sound continuously because the set temp high alarm has also been activated and the clock signal at U14-C (pin 11) is blocked out by the low at U14-C (pin 12). In addition to sounding the alarm, the high at U19-B (pin 1) turns off the SSR via U16-F, U20B, and U16-E (pin 10). The output of U16-E (pin 10) is also connected to U17-B (pin 5). U17-B will disconnect the Heater Coil via Q1 and K1 after one Master Clock pulse.

This alarm is not resettable because of the nature of the alarm (the defective probe must be replaced). However, if a set temp high alarm occurred indicating that the probe failure is related to either skin\* or air, the SET TEMP lamp will stop flashing and stay on continuously after reset.

TEMP FAIL (SETPOINT) ALARM CIRCUITRY The Temp Fail (Set temp) Alarm Circuitry is split between the analog and digital portions of PCB2. The following discussion is divided accordingly.

ANALOG (Figs. 3.2, 7.1 or 7.2) The output of the Air Data or Skin Data\* circuitry is applied to the Temp. Fail (Set Temp) circuitry. In the Air Mode, when the air temperature falls 3.0°C below set temp, the output of Error Amplifier AR6-1 will go to +8.8 volts. This +8.8 volts applied to AR9-3 (pin 4) causes AR9-3 (pin 2) to go low and activate the Set Temp Low Alarm circuitry. When the air temperature rises 1.5°C above set temp, the output of AR6-1 goes to -5.0 volts. This -5.0 volts is applied to AR9-4 (pin 7) and causes AR9-4 (pin 1) to go low and activate the Set Temp High Alarm circuitry.

\* Model C100 only.

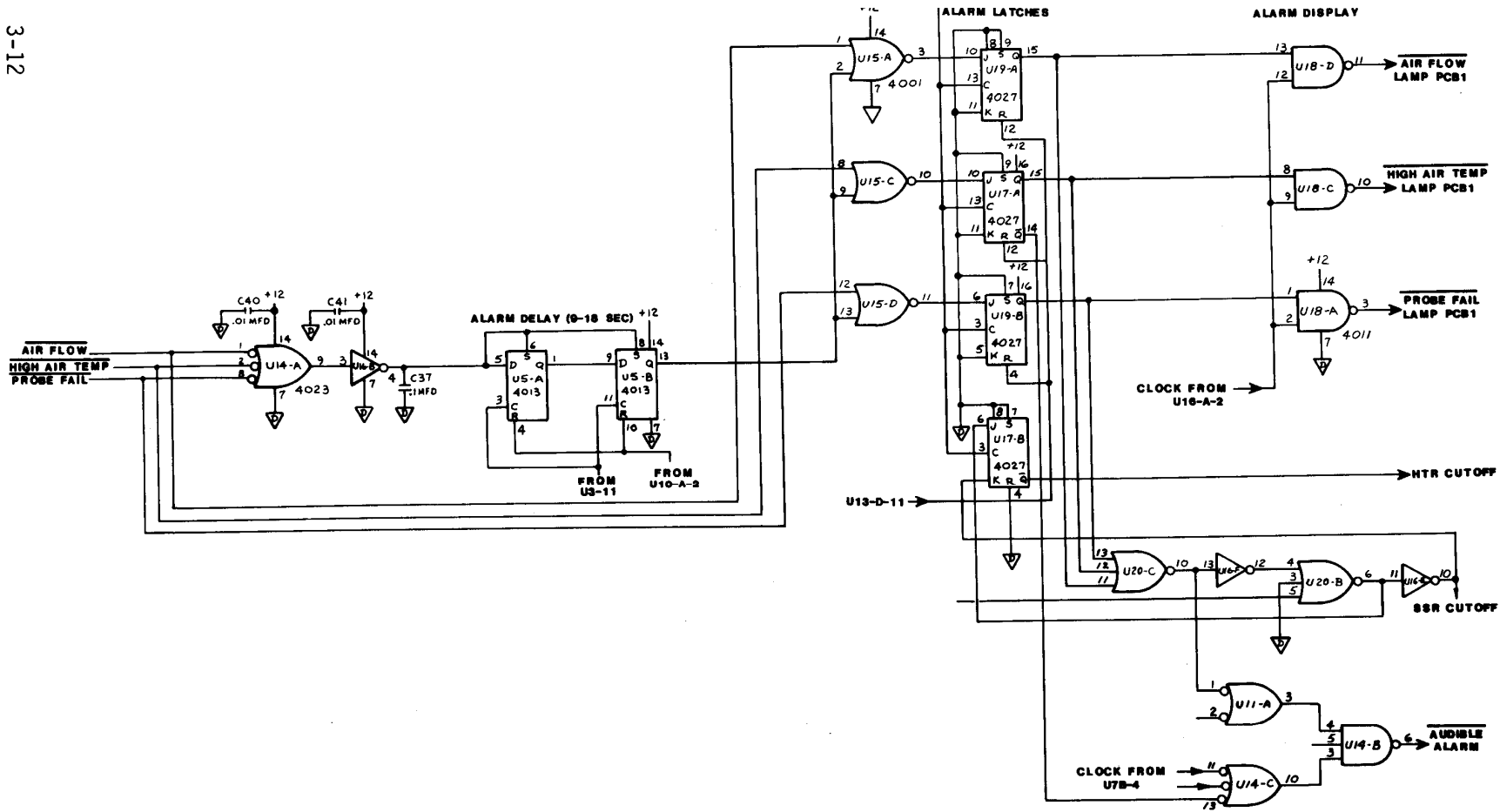

FIGURE 3.3 FUNCTIONAL BLOCK DIAGRAM, AIR FLOW, HIGH AIR TEMP.  
AND PROBE FAILURE ALARM CIRCUITRY

\*In the Skin Mode when the skin temperature rises above or falls below 1°C of set temp, the output of Error Amplifier AR6-4 will go to either plus or minus 5 volts. This voltage is applied through S1-C (pin 6) to AR9-3 and AR9-4, which control the Low and High SET TEMP alarm circuits, respectively. When the voltage is +5 volts, the SET TEMP Low Alarm is activated; when the voltage is -5 volts the SET TEMP High alarm is activated.

DIGITAL - SET TEMP HIGH ALARM (Figs. 3.4, 7.1 or 7.2) When a Set Temp High Alarm occurs a logic low is applied to U11-B (pin 6), U14-C (pin 12), and U20-A (pin 1). The low at U11-B (pin 6) activates the (9-18 SEC) Set Temp Alarm Delay (U12-A and U12-B) and places U15-B (pin 5) low. After the delay circuitry times out, U12-B (pin 13) goes low and places U15-B (pin 6) low which activates U18-B (pin 4) and flashes the SET TEMP lamp on the front panel (Note the clock pulses on U18-B (pin 6) from U13-B (pin 4)).

The low at U14-C (pin 12) activates the Audible Alarm continuously after an 8 to 9 second delay. The audible alarm delay is controlled by the output of U9-C and U11-A.

The low at U20-A (pin 1) cuts off the Solid State Relay K1 via U20-B and U16-E. This occurs 9 to 18 seconds after the alarm because of the input at U20-A pin 8 from the delay circuitry. The output of U16-E (pin 10) is also applied to U17-B (pin 5), which after one Master Clock pulse, disconnects the Heater Coil via Q1 and K1.

This alarm may be silenced for a period of 15 minutes, refer to the 15 Minute Timer Circuit description.

DIGITAL - SETPOINT LOW ALARM (Figs. 3.5, 7.1 or 7.2) A Set Temp Low Alarm occurs when the skin\* or air temperature is below the setting of the set temp switches. This alarm is disabled for one hour after turn on.

When a set temp low alarm occurs a logic low is applied to U8-A (pin 5) and U16-D (pin 9). The low at U16-D (pin 9) is inverted and applied to U11-D (pin 13). U11-D (pin 11) will go low if U11-D (pin 12) is at a logic high. U11-D (pin 12) can only be high one hour after turn on or 2.5 minutes after set temp is reached; refer to the One Hour Timer circuit description.

\* Model C100 only.

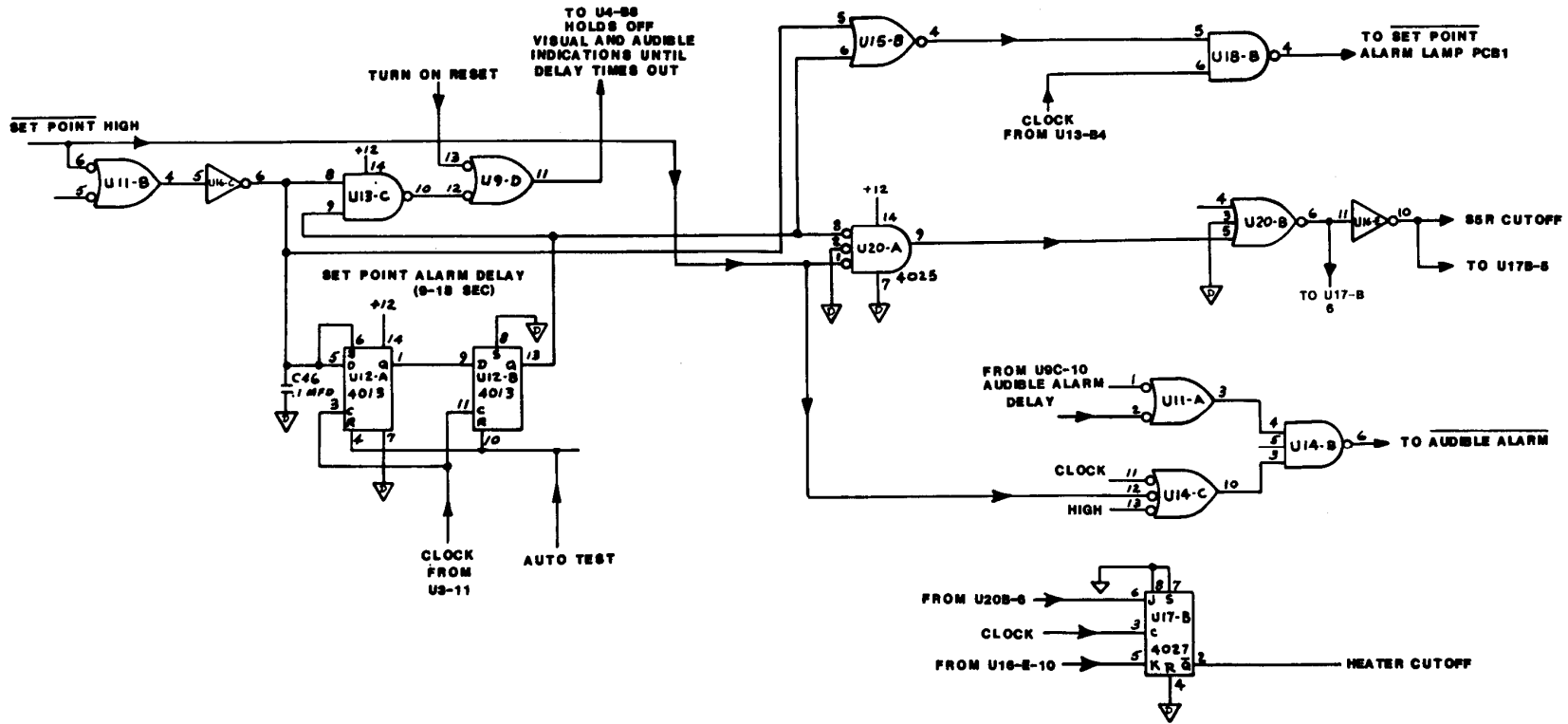

FIGURE 3.4 FUNCTIONAL BLOCK DIAGRAM, SET TEMP HIGH ALARM CIRCUITRY

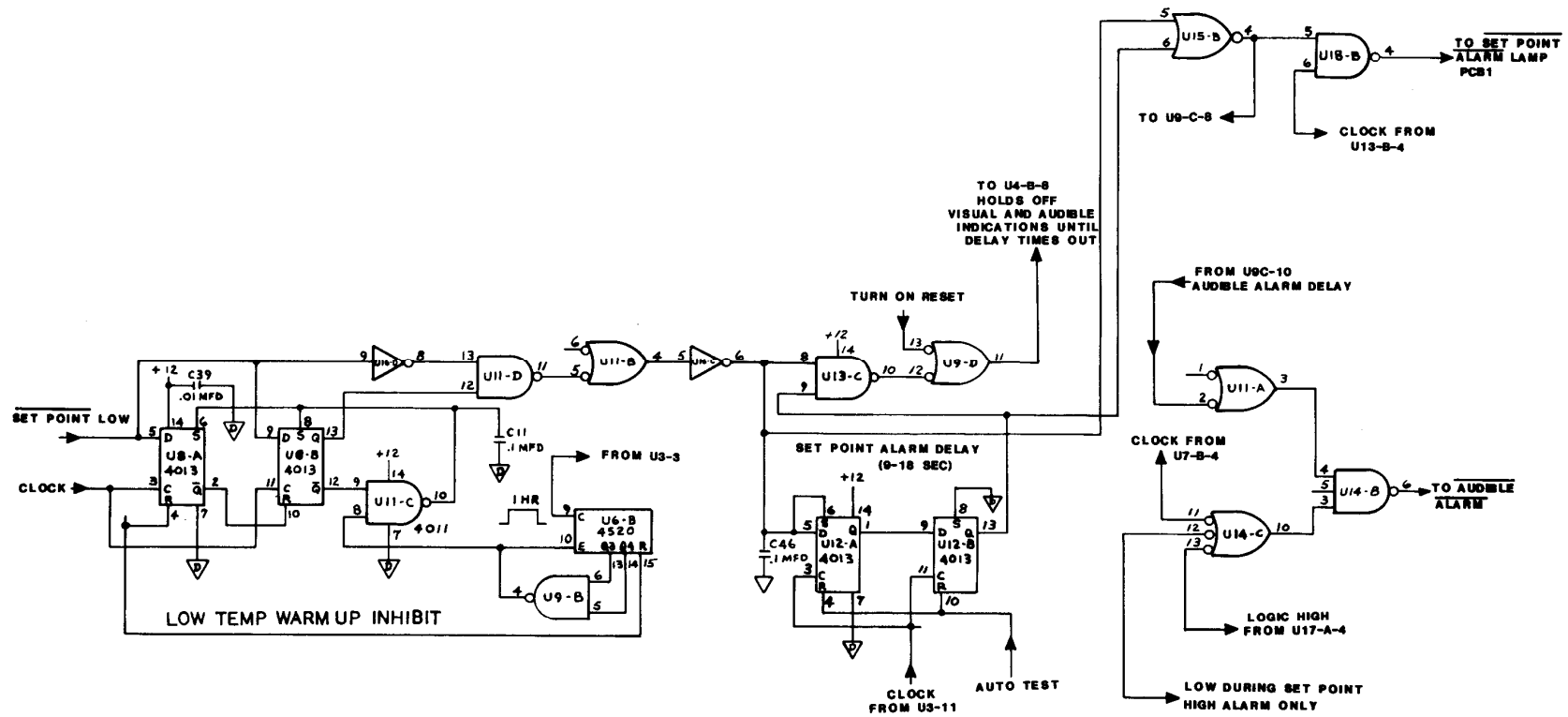

FIGURE 3.5 FUNCTIONAL BLOCK DIAGRAM, SET TEMP LOW ALARM CIRCUITRY

TECHNICAL INFORMATION  
C100/200

C100/200  
TECHNICAL INFORMATION

When U11-D (pin 11) goes low, the 9-to-18 second delay timer is activated by U11-B (pin 4) and U16-C (pin 6). After the delay circuit times out, U12-B (pin 13) goes low and places U15-B (pin 6) low which activates U18-B (pin 4) and flashes the SET TEMP light (note the clock pulses on U18-B (pin 6) from U13-B (pin 4)).

The audible alarm will be pulsed on and off because of the following conditions. U14-C (pins 12 and 13) are at a logic high which permits the clock at pin 11 to be gated through to U14-B (pin 3). U14-B (pin 5) is at a logic high after the auto sequence (refer to Auto Test Circuit description). U14-B (pin 4) is at a logic high because there are no other alarms and the SILENCE/RESET button has not been depressed. This alarm may be silenced for a period of 15 minutes, refer to the 15 Minute Timer Circuit description.

AIR FLOW ALARM CIRCUITRY The Air Flow Alarm Circuitry is split between analog and digital portions of PCB2. The following discussion is divided accordingly.

ANALOG (Figs. 3.2, 7.1 or 7.2) Thermistor RT4, which is located between the Heater and Fan, is heated by the current flow from +12 volts via R31 to ground. This current flow maintains the voltage at the junction of R31 and R40 at approximately +11.0 volts. In the event that the fan stops turning, the voltage at the junction of R31/R40 will go to approximately +6 volts due to the rise in temperature. The +6 volts at the input of AR7-2 will cause its output to rise to +5.5 volts and cause the output of comparator AR3-4 (pin 13) to go low and activate the Air Flow Alarm circuitry. If RT4 shorts the output of AR7-2 will rise to approximately 11.0 volts and cause the output of comparator AR3-4 (pin 13) to go low and activate the Air Flow Alarm circuitry.

If RT4 opens, the output of AR7-2 pin 7 will go to approximately -8 volts. This -8 volts will cause AR3-2 (pin 14) to go low and activate the Probe Fail Alarm circuitry.

DIGITAL (Figs. 3.3, 7.1 or 7.2) An Air Flow Alarm occurs when the Air Circulation across the heater coil stops.

When an Air Flow Alarm occurs, a logic low is applied to U14-A (pin 1). This low causes U16-B (pin 4) to go low and start the 9- to 18-second Delay Timer U5-A and U5-B. After the timer times out, U5-B (pin 13) goes low and is applied to U15-D (pin 13), U15-C (pin 9), and U15-A (pin 2).

The low at U14-A (pin 1) is also applied to U15-A pin 1, thus determining that the alarm is an Air Flow Alarm. U15-A (pin 3) goes high and will set latch U19-A (pin 15) high at the next clock pulse.

The high at U19-A (pin 15) is applied to U18-D (pin 13) whose other input is the flashing signal from the Alarm Flash Circuitry U16-A (pin 2). The output of U18-D (pin 11) then flashes the AIR FLOW lamp on the front panel.

The output of U19-A (pin 15) is also applied to U20-C (pin 11) which sounds the pulsating audible alarm via U11-A and U14-B. In addition, it turns off the SSR via U16-F, U20-B, and U16-E (pin 10). The output of U16-E (pin 10) is also connected to U17-B (pin 5). U17-B will disconnect the Heater Coil via Q1 and K1 after one Master Clock pulse.

When the SILENCE/RESET button is depressed, latch U19-A will be reset via U13-D. However, if the alarm condition still exists, the latch will be set again at the next Master Clock pulse.

HIGH AIR TEMPERATURE ALARM CIRCUITRY The High Air Temperature Alarm Circuitry is split between the analog and digital portion of PCB2. The following discussion is divided accordingly.

ANALOG (Figs. 3.2, 7.1 or 7.2) The High Air Temperature Circuitry is controlled by thermistor RT1-B. As long as the Air Temperature is between 20 and 39.5°C, the voltage at input of AR2-1 (pin 5/6) will be greater than 2.6 volts. When the air temperature rises above 39.5°C the input voltage falls below 2.6 volts and the output of AR2-1 (pin 7) will go low and activate the High Air Temperature Alarm Circuitry. In the event that the thermistor shorts the output of AR2-1 (pin 7) will also go low and activate the High Air Temperature Alarm circuitry.

If RT1-B opens the output of AR3-1 (pin 2) will go low and activate the Probe Failure Alarm Circuitry.

DIGITAL (Figs. 3.3, 7.1 or 7.2) When a High Air Temperature Alarm occurs, a logic low is applied to U14-A (pin 2). This low causes U16-B (pin 4) to go low and start the 9- to 18- second Delay Timer U5-A and U5-B. After the timer times out, U5-B (pin 13) goes low and is applied to U15-D (pin 13), U15-C (pin 9), and U15-A (pin 2).

C100/200  
TECHNICAL INFORMATION

The low at U14-A (pin 2) is also applied to U15-C (pin 8) thus determining that the alarm is a High Air Temperature Alarm. U15-C (pin 10) goes high and will set latch U17-A (pin 15) high at the next clock pulse.

The high at U17-A (pin 15) is applied to U18-C (pin 8) whose other input is the flashing signal from the Alarm Flash Circuitry U16-A (pin 2). The output of U18-C (pin 10) then flashes the HIGH TEMP lamp on the front panel.

The output of U17-A (pin 15) is also applied to U20-C (pin 11) which sounds the audible alarm continuously via U11-A and U14-B. The alarm will sound continuously and not pulsate because U17-A (pin 14) is low and is connected to U14-C (pin 13). This low blocks out the flashing signal at U14-C (pin 11). In addition to sounding the alarm, the high at U17-A (pin 15) turns off the SSR via U16-F, U20-B, and U16-E (pin 10). The output of U16-E (pin 10) is also connected to U17-B (pin 5). U17-B will disconnect the Heater Coil via Q1 and K1 after one Master Clock pulse.

When the SILENCE/RESET button is depressed, latch U17-A will be reset via U13-D. However, if the alarm condition still exists, the latch will be set again at the next Master Clock pulse.

38°C\*\* AIR LIMIT CIRCUITRY (Figs. 3.2, 7.1 or 7.2) The function of the 38°C\*\* Air Limit Circuitry is to shut down the heater when the Incubator air temperature exceeds 38°C\*\*. When the output of AR4-1 (pin 1) goes above 3.6 volts (38°C) (see Note Below) the output of AR6-2 (pin 14) goes high and shuts down the Temperature Control Circuitry which in turn will shut down the Heater Control Circuitry.

TEMPERATURE CONTROL CIRCUITRY (Figs. 3.2, 7.1 or 7.2) Upon initial turn on, the air temperature of the Incubator or the infants skin temperature will be low and the error voltage at TP20 (air) or TP13 (skin\*) will be highly positive. This positive voltage saturates AR6-3 negative. This negative saturation forward biases CR17 and cancels out the positive voltage at the junction of CR21 and R79 and drives it to approximately -6.0 volts.

This -6 Volts bias drives the output of AR8-1 to ground potential in approximately 1/2 second because of the time constant developed by R67 and C25. This in effect cancels AR8-1 out of the circuit and permits the Heater Control Circuitry to apply full power to the Heater.

\* Model C100 only.

\*\* 38.5°C in current production Incubators and in Incubators that have been retrofitted for Air Temperature limit of 38.5°C. See Tables 6.9 and 6.11 for details.

NOTE: 3.7 volts (38.5°C) in current production Incubators and Incubators that have been retrofitted for Air Temperature Limit of 38.5°C.



As the temperature approaches control point, the voltage at TP20 becomes less positive, this in turn causes the output of AR6-3 to become less negative. At approximately 0.9°C below set temp AR6-3 comes out of negative saturation and goes toward 0. This in turn causes the voltage at the junction of R79 and CR21 to rise toward 0 and then go positive as the temperature in the Incubator reaches set temp.

This positive voltage turns CR21 off and causes the output of AR8-1 to go negative at a time constant of 1 minute created by C26 and R68. This negative voltage is applied to the summing point of R70 and R72 and will cancel any overshoot as the temperature reaches set temp. In addition, if the door is opened, the temperature will drop and TP20 will go positive and drive AR8-1 into saturation and permit the Heater to go on full. After the door is closed, the temperature will rise and AR8-1 will function as previously described to cancel any overshoot as the temperature reaches set temp.

The voltage at the summing point of R70 and R72 is applied to AR1-2. The output of AR1-2 is limited to +4.0 volts at full power by the Temperature Control circuitry and varies between +1 and +2 volts (1/4 to 1/2 power) at set temp.

HEATER CONTROL CIRCUITRY (Figs. 3.2, 7.1 or 7.2) AR1-4 and its associated circuitry provide a variable triangular waveform as illustrated in Figure 3.6.

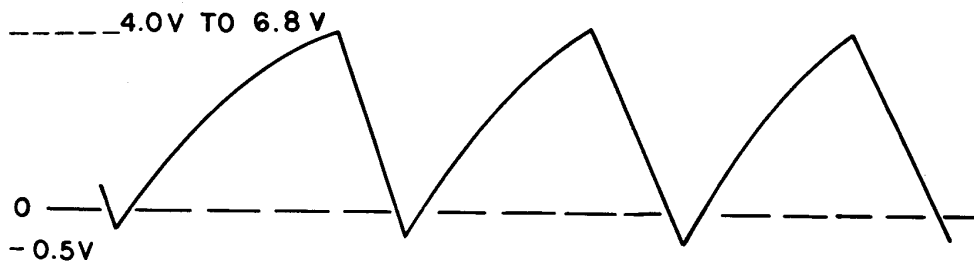

FIGURE 3.6 VARIABLE TRIANGULAR WAVEFORM

C100/200  
TECHNICAL INFORMATION

The amplitude of the waveform is directly effected by the +22V unregulated voltage which supplies voltage divider network R96, R97, and R100. Since the +22 volt unregulated supply will drift up and down with the ac line voltage, the amplitude of the waveform will also increase and decrease with increases and decreases of ac line voltage. This varying triangular waveform is one input to AR1-3 which controls Heater Relay K1 and SSR (Solid State Relay). The other input to AR1-3 is the output of the Temperature Control Circuitry.

As illustrated in Figure 3.7 when full power is required and the line voltage is 95 Vac the output of AR1-3 (TP-15) will be -12 volts constantly, because the output of the temperature control circuitry is +4.0 volts and the amplitude of the triangular waveform will never rise above 4.0 volts.

When full power is required at a line voltage of 135 Vac the output of AR1-3 will be off (positive) for 54% of the time which is the amount of time the triangular waveform is above the 4.0 volt bias level supplied by the temperature control circuitry.

Similarly at a line voltage of 120 Vac the output of AR1-3 will be off (positive) for 36% of the time which the amount of time the triangular waveform is above the 4.0 volt bias level supplied by the Temperature Control Circuitry.

When the temperature of the Incubator reaches set temp, the output of AR1-3 will be off (positive) for 75% of the time which is the amount of time the triangular waveform is above the +1.0 to 2.0 volts bias level supplied by the Temperature Control Circuitry.

HEATER COIL CIRCUITRY (Figs. 3.2, 7.1 or 7.2) The Heater Coil HTR1 is connected across the ac line and is turned on and off by Heater Power relay K1 which is a solid state relay controlled by the Heater Control circuitry described above.

POWER FAILURE ALARM (PFA) AND AUDIBLE ALARM CIRCUITRY (Figs. 3.2, 7.1 or 7.2) The Power Failure Alarm (PFA) and Audible Alarm circuitry consists of Q2, U21, DS1, and ENTRY 1. When the POWER switch (S1-3C-4C) is on and the ac line voltage is absent, the -12 volts which keeps Q1 turned on and U21 and DS1 off, will disappear and the battery will activate DS1 and turn on the POWER FAIL indicator on PCB1. During an alarm condition the alarm is activated by a logic low from the digital logic circuitry at TP7.

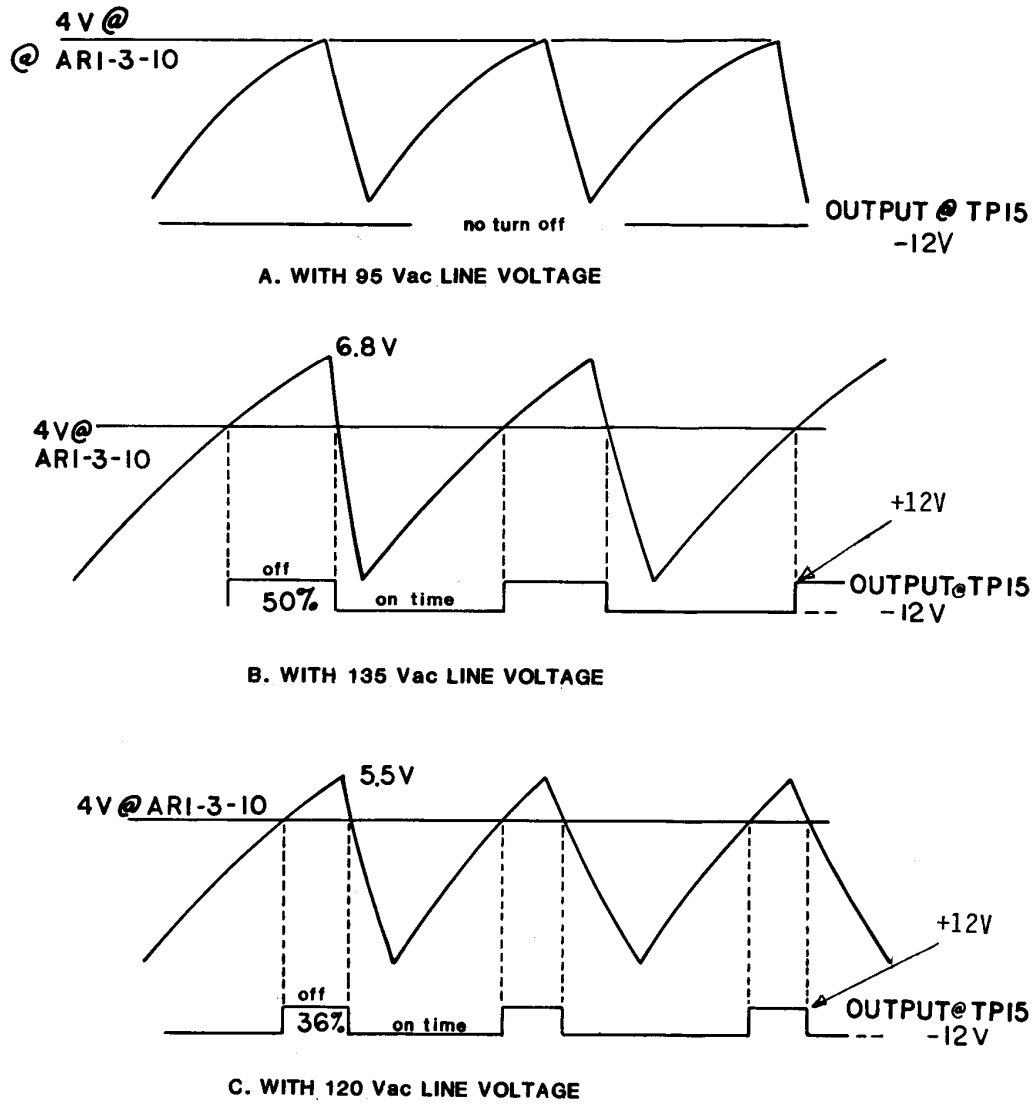

FIGURE 3.7 HEATER POWER CONTROL AT FULL POWER

HEATER CUT OFF CIRCUITRY (Figs. 3.2, 7.1 or 7.2) Transistor Q1 will disconnect the Heater from the ac line via relay K1 during all alarm conditions except SET TEMP low. The alarm circuitry is discussed in detail elsewhere in this section.

POWER SUPPLY (Figs. 3.2, 7.1 or 7.2) The power supply accepts a voltage from the secondary of T1 and puts out  $\pm 12$  volts regulated dc via VR1 and VR2. The +12 Vdc is also regulated at +5 Vdc by VR3. The output of VR3 is also applied to inverter AR7-1 which supplies a -5.0 Vdc which tracks the +5.0 Vdc.

The power supply also provides an unregulated +5.0 Vdc for the LED's and unregulated -22 Vdc for the Heater Control Circuitry.

POWER UP RESET (Figs. 3.8, 7.1 or 7.2) The Power Up Reset circuitry consists of U7-C, U7-D, U9-A and RC network R114 and C35. Upon turn on, C35 is discharged and the outputs of gates U7-C, U7-D, and U9-A are high until C35 charges up and then they go low. This logic low resets the counters and starts the Master Clock.

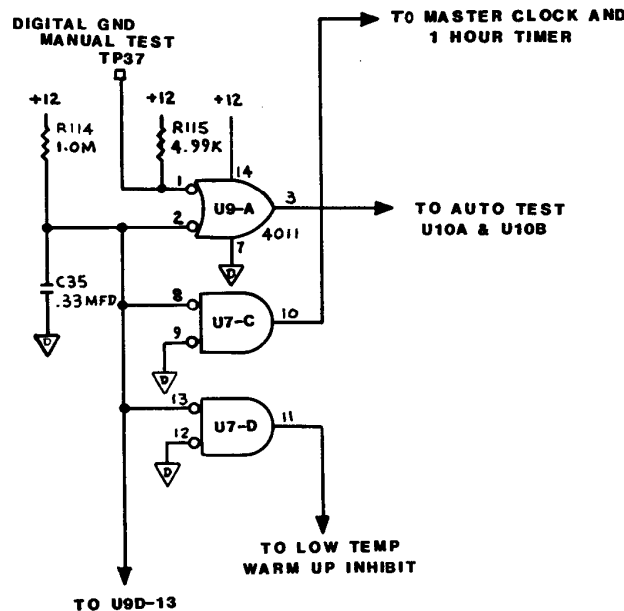

**FIGURE 3.8 FUNCTIONAL BLOCK DIAGRAM, POWER UP RESET**

MASTER CLOCK (Figs. 3.9, 7.1 and 7.2) The Master Clock consists of U2-C and U2-D. It is an RC ring oscillator which provides a 0.833 Hz squarewave.

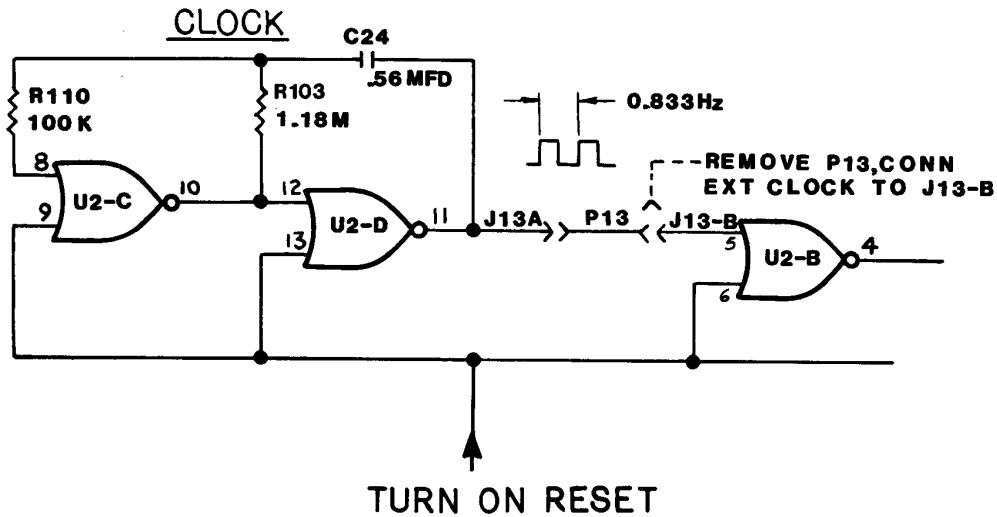

**FIGURE 3.9 FUNCTIONAL BLOCK DIAGRAM, MASTER CLOCK**

ONE HOUR TIMER (Figs. 3.10, 7.1 and 7.2) The function of the One Hour Timer is to disable the Low Temperature Set Temp alarm for a period of one hour after turn on to permit the Incubator to warm up.

The 1.2 second Master Clock is buffered by U2-B and U2-A and is applied to the clock input of U4-A a dual "D" flip flop which is hooked in a divide by 2 configuration. The output of U4-A is applied to U3 a binary, ripple counter. The Q7 output (pin 3) of U3 then provides a 5.0 minute period clock (2.5 minutes high, 2.5 minutes low) to the clock input of U6-B.

Pins 13 and 14 of U6-B (a synchronous up counter) will go high after twelve 5.12 period clock pulses (1 hour) and disable U6-B via U9-B pin 4. The logic low at U9-B pin 4 is also applied to U11-C pin 8 which disables the Low Temp Warm Up inhibit flip-flops U8-A and U8-B and permits the Set Temp Low Alarm (if present) signal at U16-D (pin 9) to be gated through.

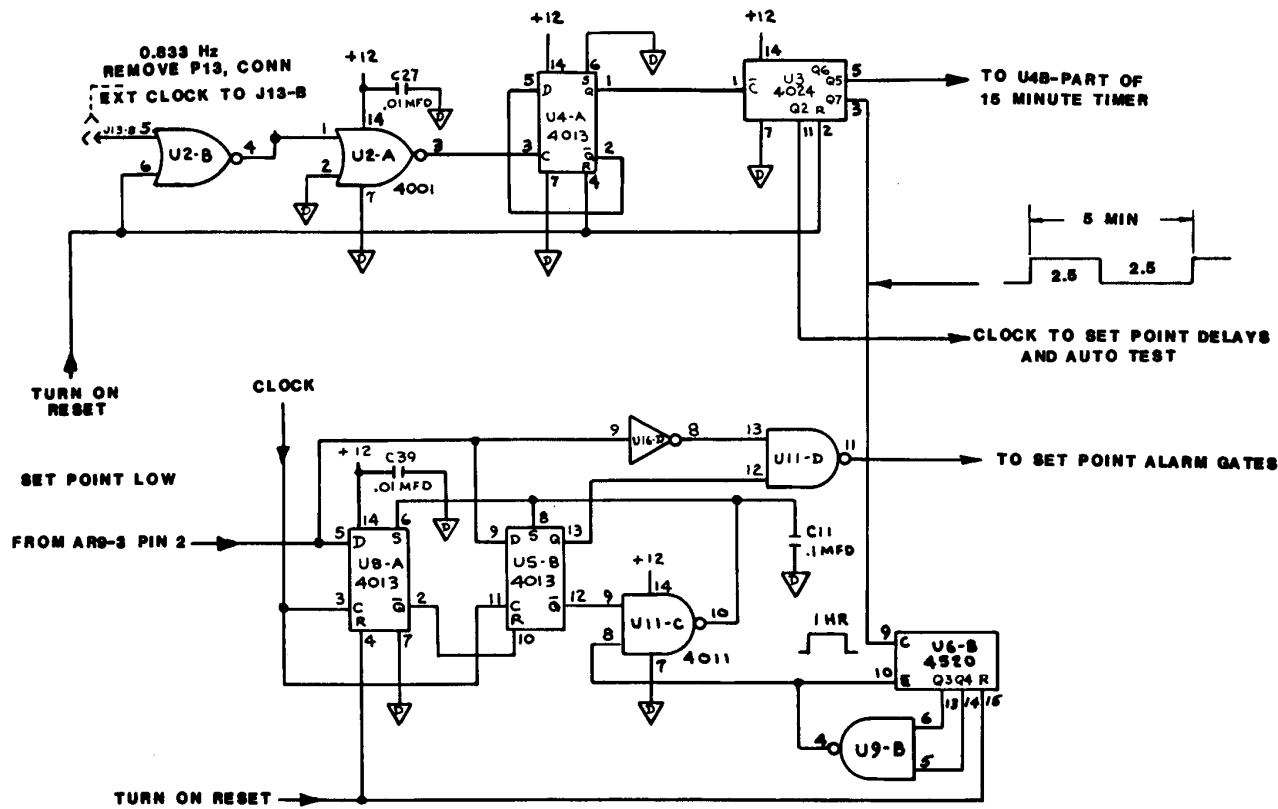

FIGURE 3.10 FUNCTIONAL BLOCK DIAGRAM, ONE HOUR TIMER

If the temperature reaches set temp before one hour, the signal at U8-A (pin 5) goes high. This low to high transition resets the One Hour Timer after a period of 1-1/4 to 2-1/2 minutes (one clock pulse). This delay provides the operator with time to raise the set temp and still keep the One Hour Timer in effect.

15 MINUTE TIMER (Figs. 3.11, 7.1 or 7.2) The purpose of the 15 Minute Timer is to silence the high and low set temp alarms for a period of 15 minutes after the SILENCE/RESET button is depressed.

When the SILENCE/RESET (S2) button is depressed, a logic low is applied to U13-D (pin 13) and U7-A (pin 1). The low at U7-A (pin 1) along with the low at U7-A (pin 2) provides a reset to 15 minute timer U4-B and dual "D" flip-flop U6-A via U7-A (pin 3). Upon reset, U4B (pin 13) will go low and U6-A will begin to count. After a period of 15 minutes, U6-A (pin 6) will go high, and as a result, U4-B (pin 13) will again go high.

The 15 minute low at U4-B (pin 13) is applied to U9-C (pin 9). This low provides a high to U11-A (pin 2), which in conjunction with U11-A (pin 1) blocks the audible alarm. As stated previously, after a period of 15 minutes U4-B (pin 3) goes high and permits the audible alarm to sound.

AUTO TEST (Figs. 3.12, 7.1 or 7.2) Upon turn on, the Auto Test Circuit will activate alarm lamps, and the Digital Display will show all eights for a period of 5 seconds.

When the unit is turned on, U9-A (pin 3) of the reset circuitry resets U10-A and U10-B. Upon reset, U10-A (pin 2) will go high for a period of 5 seconds. This low is applied to PCB1 via J12-20 and causes the Digital Display to show all eights. The logic high at U10-A (pin 2) is also applied to analog switch U1-A, U1-B, U1-C, and U1-D. When these switches turn on, U1-A, U1-B, and U1-D short thermistors RT1-A, RT1-B, and RT2\* which creates alarm conditions. Switch U1-C puts AR7-2 (pin 6) to ground via a 10.0K resistor which simulates an Air Flow failure. This logic high also disables the Set Temp Alarm Delay circuitry.

Also, upon reset U10-A (pin 1) goes low, this low is applied to U13-A pin 2 which holds the Alarm Latch resets low via U13-D (pin 11). Since the Alarm Delay timer is disabled, U5-B (pin 13) is low, this permits the alarm inputs at U14-A to be gated through the Alarm Latches and turn on the AIR FLOW, HIGH TEMP, and PROBE alarm lights via U18-A, U18-C, and U18-D.

\* Model C100 only.

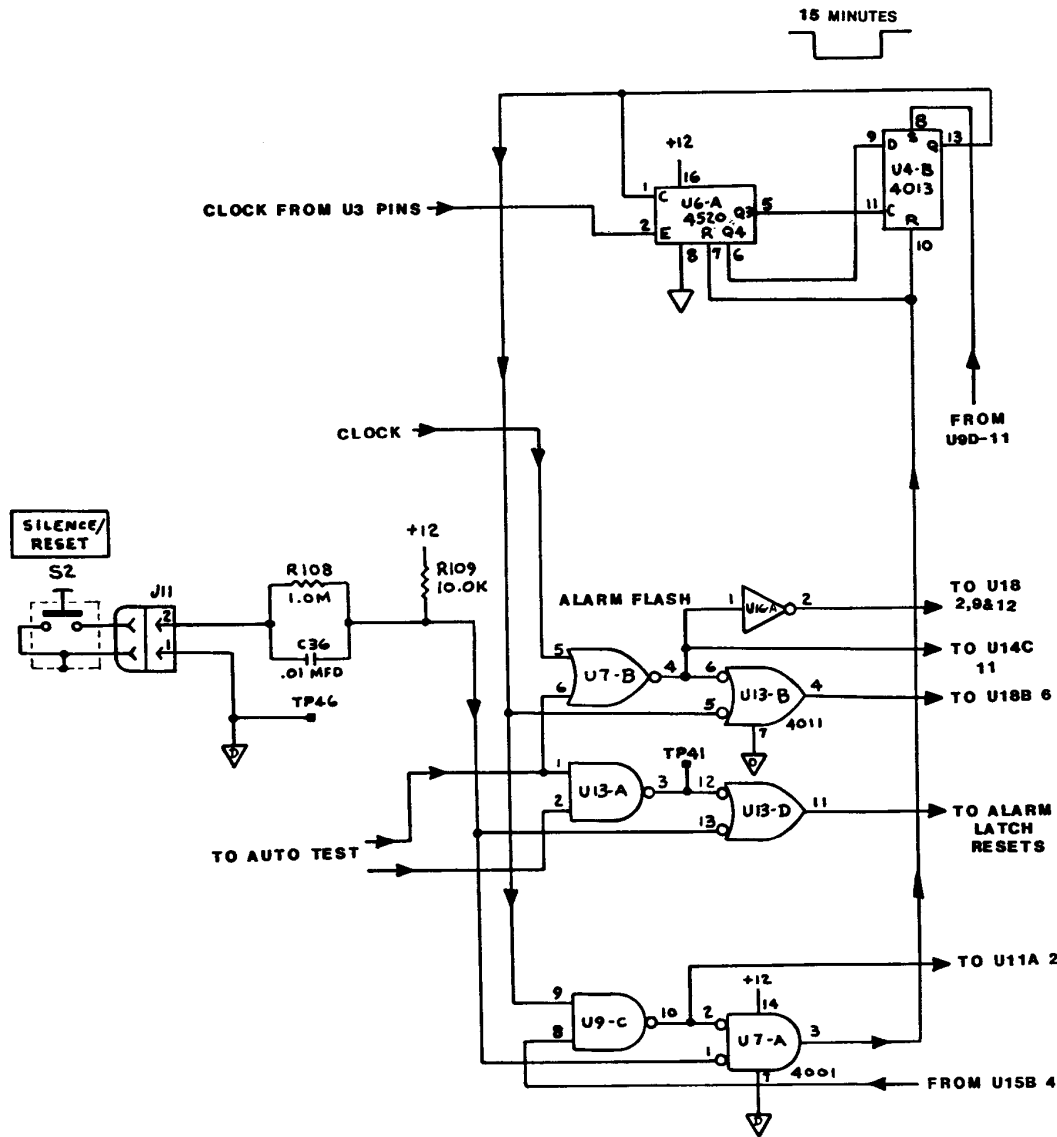

FIGURE 3.11 FUNCTIONAL BLOCK DIAGRAM, 15 MINUTE TIMER



Since the SET TEMP ALARM DELAY timer is also disabled, U12-B (pin 13) is low. This low will turn on the SET TEMP light via U15-B and U18-B. Upon completion of 5 seconds, U10-A and U10-B return to normal and cancel the Auto Test sequence.

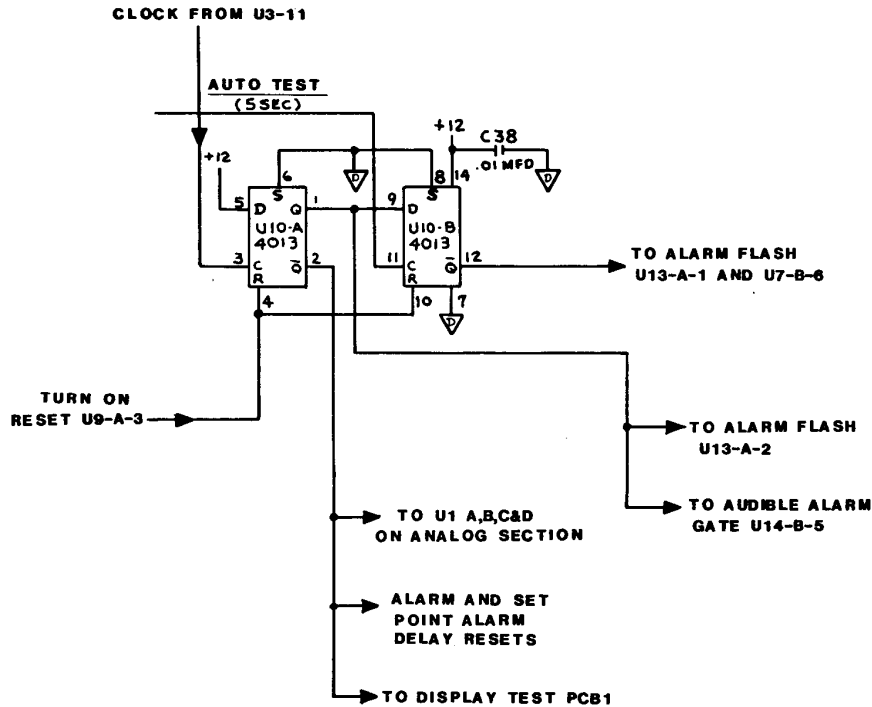

FIGURE 3.12 FUNCTIONAL BLOCK DIAGRAM, AUTO TEST

### 3.3.3 CONTROLLER DISPLAYS (PCB1)

PCB1 contains the Air and Skin\* temperature digital displays, alarm indicators, and Heater Power indicators.

**DIGITAL DISPLAYS** (Figs. 3.13, 7.1 or 7.2) U1\* and U2 are analog to digital converters which provide 3 digit seven segment outputs. During Auto Test a logic high from U10-A (pin 2) on PCB2 is applied to pin 37 of each converter(s) via buffer U3-1 and U3-6. This high puts U1\* and U2 in the test mode and the Digital Display(s) will read all eights.

Since the operation of the SKIN\* and AIR A/D converters are identical, only operation in the air mode will be described.

The VIN air input at J-18 comes from AR4-1 on PCB2 and is applied to pin 31 of U2. This analog voltage represents current air temperature and U2 converts it to a Digital readout.

\* Model C100 only.

C100/200  
TECHNICAL INFORMATION

The Display Blank Circuit consists of CR6, CR7, and CR8. When the input signal is removed or the controlling thermistor opens, the junction of CR8 and R20 will go to -6.1 volts. This voltage will saturate the input of U2 (pin 31) and the Digital Display will go blank. This condition will also occur if the controlling thermistor shorts.

The Gain Control (R18) calibrates U2 at 36°C. The Offset Control R13 calibrates U2 at 20°C.

ALARM INDICATORS (Figs. 3.13, 7.1 or 7.2) When an alarm condition occurs, a pulsating logic low is applied to the appropriate input of U3-2, -3, -4, or -5 which activates the appropriate alarm lamp. Also, if there is a power failure, the battery voltage is applied to J1-9 (PCB1) which lights the POWER FAIL lamp (DS1 on PCB1) via Q1 (PCB1) to indicate power failure.

HEATER POWER INDICATORS (Figs. 3.13, 7.1 or 7.2) The inverting inputs of AR1-1, AR1-2, AR1-3, and AR1-4 are connected to AR1-2 on PCB2 which is the output of the Temperature Control circuitry. As described previously, the output of this circuit is 1 to 2 volts at set temp and 4.0 volts at full power.

The non-inverting inputs of AR1-1, AR1-2, AR1-3, and AR1-4 are connected to a voltage divider network which provides reference voltages. Depending upon the voltage at the inverting input, the output of the appropriate comparator will go low and light the appropriate Power Indicator.

At 1/4 power, only AR1-1 will be on, at 1/2 power both AR1-1 and AR1-2 will be on, and at full power all the comparators will be on.

\*CONTROL MODE INDICATORS (Figs. 3.13 and 7.1). The Control Mode Indicators SKIN and AIR (DS7 and DS8), are operated by the CONTROL MODE switch S1-A on PCB2 which applies -12 volts.

### **3.4 CONTROLLER TIMING DIAGRAMS**

Timing Diagrams for the Controller are presented in Figure 3.14.

\* Model C100 only.

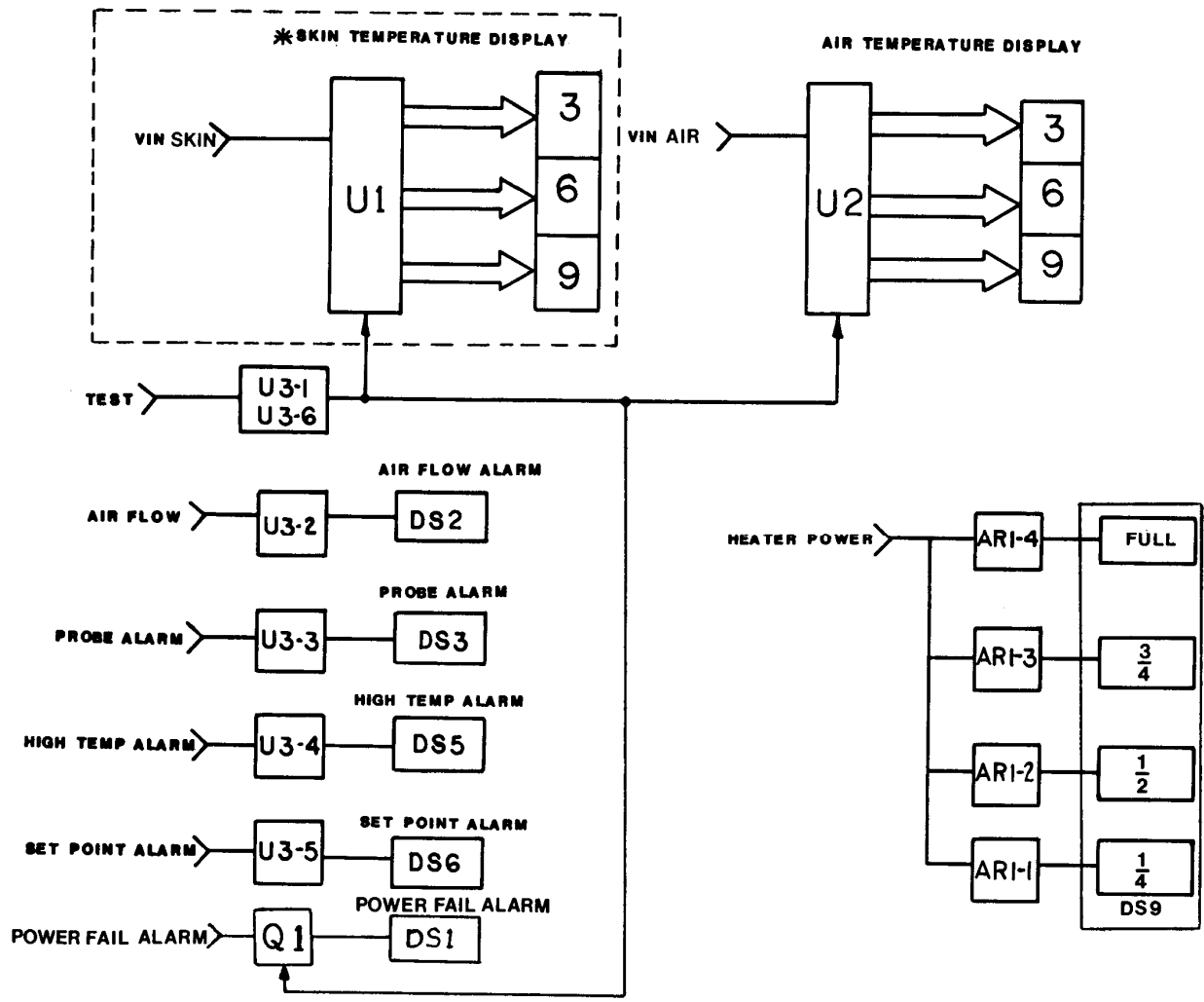

\* MODEL C100 ONLY

FIGURE 3.13 FUNCTIONAL BLOCK DIAGRAM, PCB1, CONTROLLER DISPLAYS

C100/200  
 TECHNICAL INFORMATION

HI TEMP ALARM TIMING

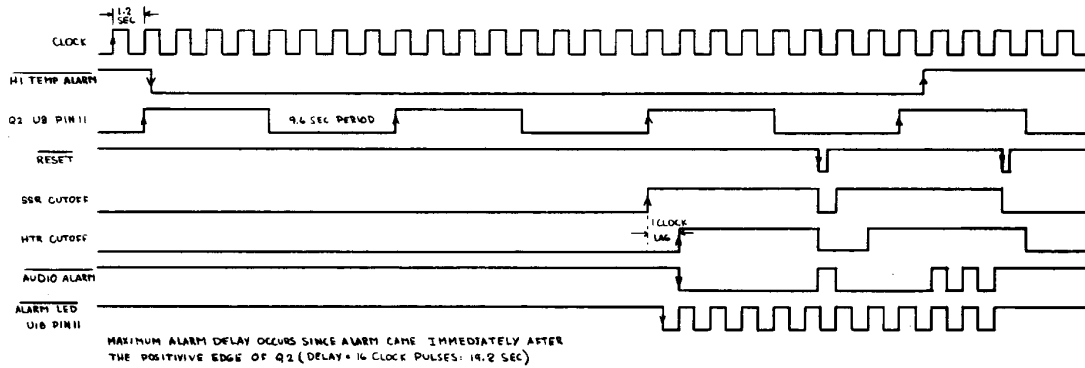

PROBE SHORT ALARM TIMING

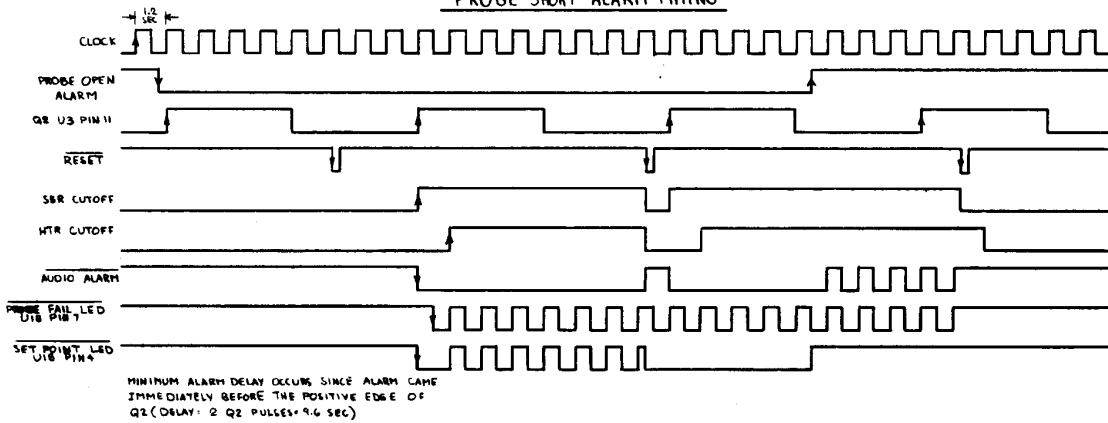

PROBE OPEN & AIRFLOW ALARM TIMING

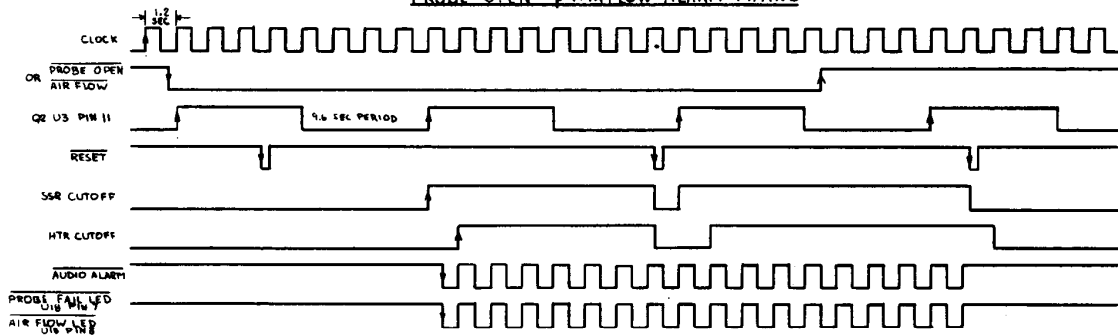
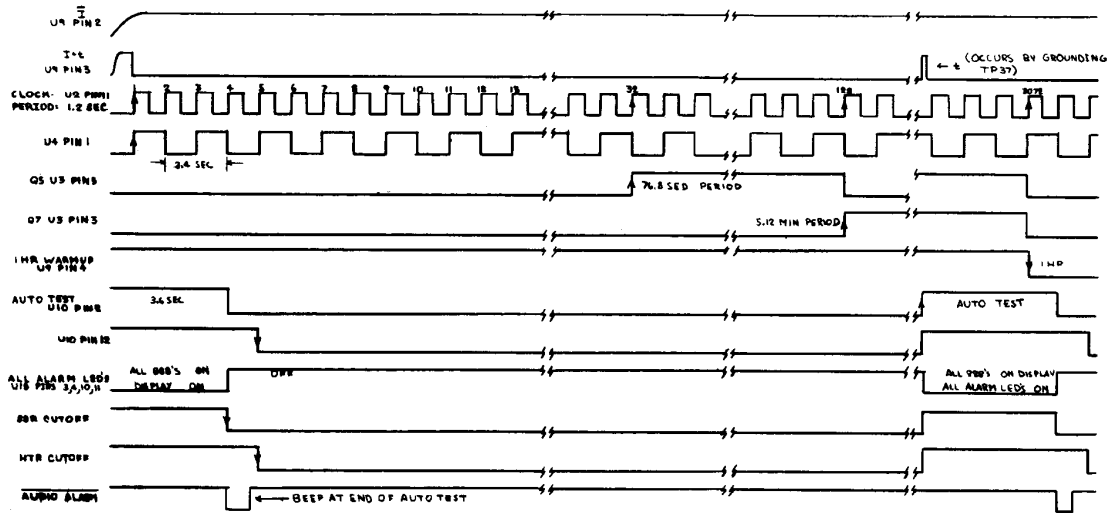
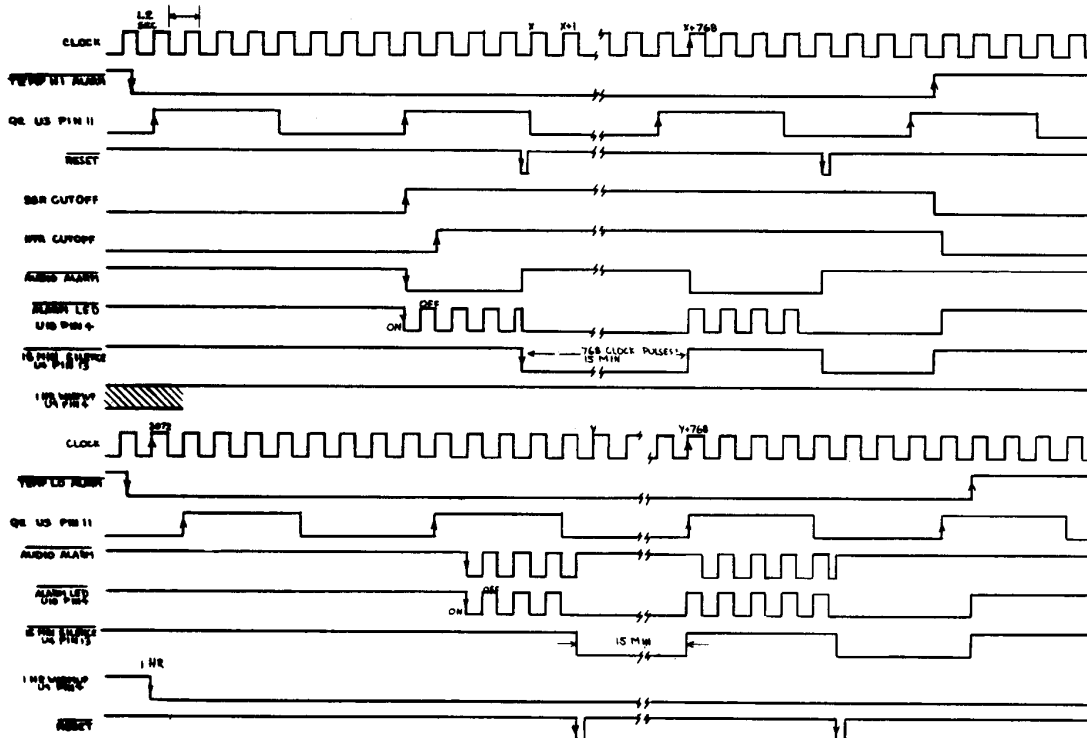

FIGURE 3.14 CONTROLLER TIMING DIAGRAM (SHEET 1 of 2)

BASIC TIMING SIGNALS



SET POINT ALARM TIMING



NOTE: 1) SR CUTOFF AND HTR CUTOFF ARE NOT EXPECTED DURING TEMP LO ALARM

FIGURE 3.14 CONTROLLER TIMING DIAGRAM (SHEET 2 of 2)

C100/200  
TECHNICAL INFORMATION

(This page is intentionally left blank.)

## SECTION 4 PREVENTIVE MAINTENANCE

### 4.1 GENERAL

This section provides preventive maintenance procedures for the Incubator. Included are routine and special cleaning instructions, sterilization procedures, and a calibration schedule.

### 4.2 CLEANING

When an infant is discharged or at least once a week, the Incubator should be thoroughly cleaned and disinfected. Cleaning can most effectively be accomplished by disassembling, then grouping the parts and/or assemblies in categories according to the method of cleaning required.

#### 4.2.1 DISASSEMBLY FOR CLEANING

NOTE: For routine cleaning there is no need to separate the Hood/Base Assembly from the Cabinet Stand. If separation is necessary refer to the Installation Section.

**WARNING:** The Controller heater can be sufficiently hot to cause burns; avoid removing the Controller or touching the heater until the unit has been switched off for at least 45 minutes.

1. REMOVE THE CONTROLLER. Disconnect the Power Cord and Probe(s) from the side of the Incubator. Release the latch on each side of the Controller as shown in Figure 4.1, then withdraw the unit from the Incubator.
- 2.\* REMOVE THE HOOD INNER WALL. Remove the Inner Wall as described in Figure 4.2.
- 3.\* REMOVE ACCESS PANEL INNER WALL (HEAT SHIELD). Refer to Figure 4.3. With the Access Panel completely open, remove the Inner Wall by simultaneously pulling out at the top and pushing in the downward direction.
4. REMOVE MATTRESS TRAY AND AIR CURTAIN COVER. Close the Access Panel and latch the Hood Assembly in the open position, then lift out the Mattress Tray. Remove and discard the disposable mattress cover. Lift the front of the Air Curtain Cover, swing it toward the back of the Incubator past the vertical position until you feel it snap free, then slide it slightly forward to remove.

\* Model C100 only. (Optional on Model C200).

C100/200  
PREVENTIVE MAINTENANCE



**FIGURE 4.1 REMOVAL OF CONTROLLER**



C100/200  
PREVENTIVE MAINTENANCE

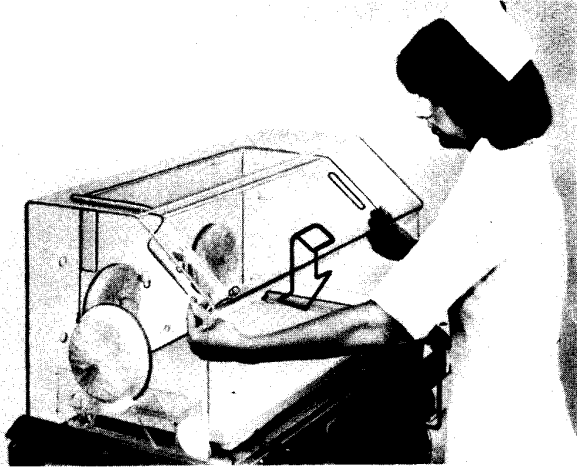

**1 RELEASE FRONT OF INNER WALL**  
by pushing slightly back in direction of hood  
slope, then down.

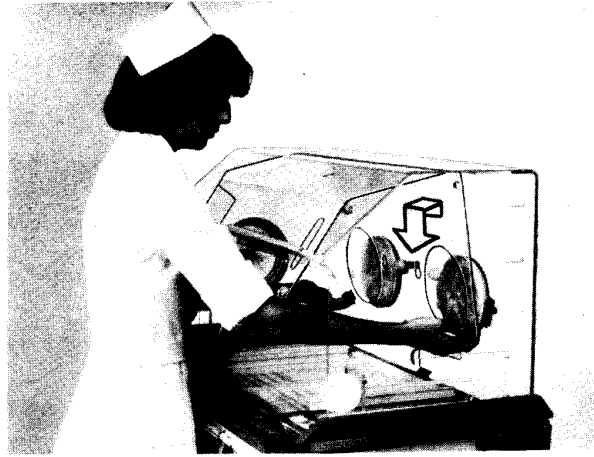

**2 RELEASE REAR OF INNER WALL**  
while resting front edge of inner wall on  
your arm; lift rear of inner wall, pull toward  
you to release, then lower.

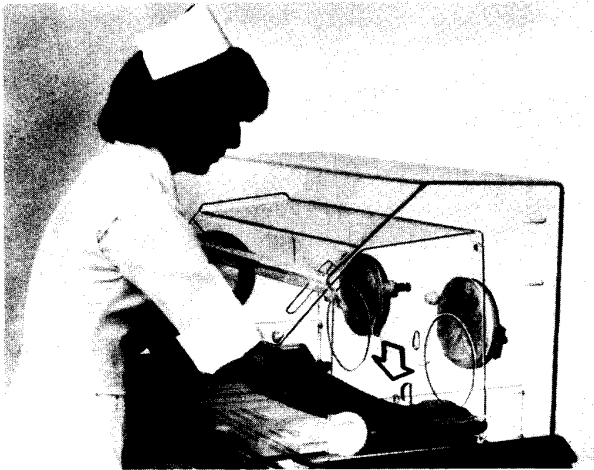

**3 LOWER REAR OF INNER WALL AS FAR AS  
IT WILL GO.**

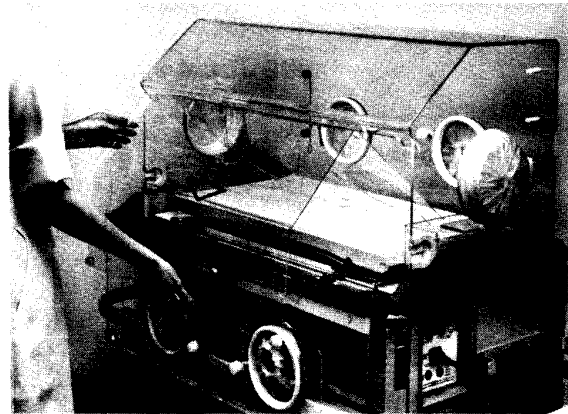

**4 REMOVE INNER WALL**  
by lowering in direction shown.

**FIGURE 4.2 REMOVAL OF INNER WALL**

\* Model C100 Only. (Optional on Model C200).

C100/200  
PREVENTIVE MAINTENANCE

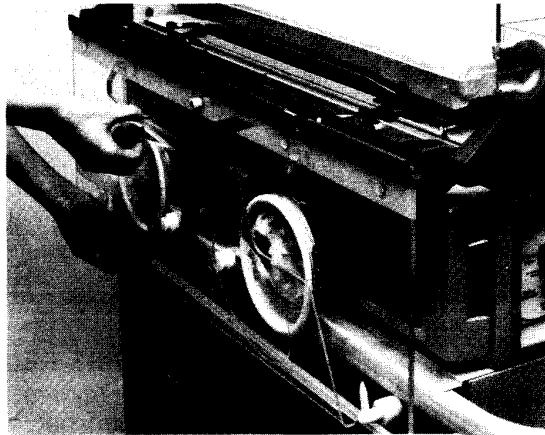

**FIGURE 4.3 ACCESS PANEL INNER WALL REMOVAL**

5. REMOVE MAIN DECK. Rotate the Main Deck Retainer (Figure 4.4) parallel with the slot, then lift out the Main Deck and Hood Seat Gasket.



**FIGURE 4.4 REMOVAL OF MAIN DECK**

\* Model C100 only. (Optional on Model C200.)

6. REMOVE AIR INTAKE TUBE. Grasp the Air Intake Tube (Figure 4.5) twist and pull it toward the front of the Incubator until the end of the tube clears the gasket. Remove the tube from the base assembly.

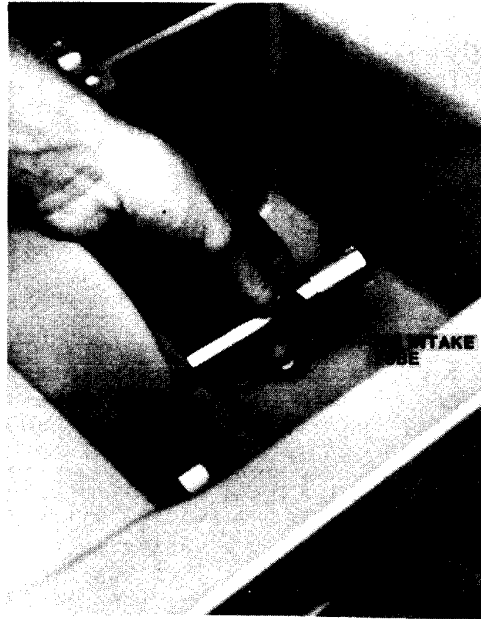

**FIGURE 4.5 REMOVAL OF AIR INTAKE TUBE**

7. REMOVE DISPOSABLE ACCESS DOOR CUFF from each Access Door Gasket by pulling it off from the outside; discard the cuffs.
8. REMOVE ACCESS DOOR GASKET from each Access Door hole by pulling it off from the outside.
9. REMOVE TUBING ACCESS PORTS from each side of the Hood by pulling them free.
10. REMOVE DISPOSABLE IRIS ENTRY PORT SLEEVES by pulling each Sleeve off the retainer rings; discard the sleeves.
11. REMOVE THE AIR-INTAKE MICROFILTER COVER by loosening the two thumbscrews.

C100/200  
PREVENTIVE MAINTENANCE

**4.2.2 CLEANING**

1. CLEANING AGENTS. An iodophor or quaternary disinfectant-detergent registered by the U.S. Environmental Protection Agency should be used, but only after the Incubator is empty and disassembled as described in paragraph 4.2.1. A cleanser such as Air-Shields® Kleenaseptic® Germicidal Surface Cleanser may be used. When using any cleaning agent follow the manufacturer's directions for use. After removing all solid wastes and contaminants from the disassembled parts, clean them as follows:
- 2.\* SKIN PROBE. Use a disinfectant-detergent to thoroughly clean all surfaces, then dry with a clean cloth or paper towel.
3. HUMIDITY CHAMBER AND FILL PIPE, AIR INTAKE TUBE, ACCESS DOOR GASKETS, TUBING ACCESS PORTS, AND MAIN DECK GASKET. Fill the humidity chamber with a disinfectant-detergent, then remove the W-shaped Baffle from the chamber and dry it with a clean cloth or paper towel. Place the Air Intake Tube, Access Door Gaskets, Tubing Access Ports, and Main Deck Gasket into the solution.

NOTE: If necessary, a larger container may be used, but if the chamber is not used, then the Fill Pipe and Humidity Chamber must be cleaned separately.

Allow them to soak as recommended by the cleaning solution manufacturer, then remove them and dry completely with a clean cloth or paper towel. Drain the Humidity Chamber, scrub it thoroughly including all indentations, then dry the chamber and Fill Pipe (inside and out) with a clean cloth or paper towel.

If necessary to remove the fill pipe for cleaning, rotate the Fill Pipe Assembly about 1/4 turn to the left. Loosen the thumbscrew that secures the Fill Pipe Bracket, and rotate the bracket 1/4 turn to the left. Unscrew the Fill Pipe Assembly by rotating counterclockwise as shown in Figure 4.6. Clean Fill Pipe Assembly and the sleeve that becomes a loose part when the Fill Pipe Assembly is unscrewed.

\* Model C100 only.

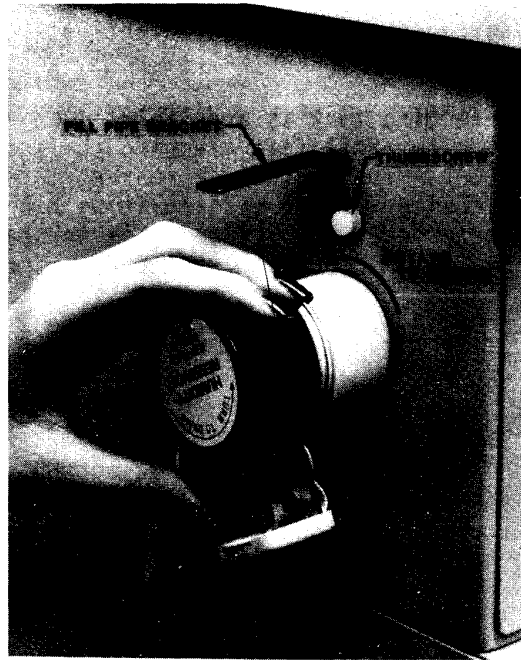

**FIGURE 4.6 REMOVAL OF HUMIDITY FILL PIPE ASSEMBLY**

4. CONTROLLER. The portions of the Controller external to the controlled incubator environment include the front panel and the top, bottom, and two sides of the chassis. These portions may be wiped clean with a cloth dampened with a disinfectant-detergent.

CAUTION: Some chemical cleaning agents may be conductive and/or leave a residue which may permit a build-up of dust or dirt which may be conductive. Do not permit cleaning agents to contact electrical components. Do not spray cleaning solutions onto any of these surfaces.

The portions of the Controller that are within the Incubator's controlled environment are on the rear surface: included are the air temperature probe, the fan impeller, the heater, the gaskets, and the surface of the Controller to which these components are mounted.

CAUTION: Failure to clean could result in sufficient lint buildup to reduce air flow, which will affect temperature control and cause high oxygen concentrations.

- A. Remove any lint buildup, pay particular attention to the fan impeller, heater, air temperature probe, and air flow sensor.

C100/200  
PREVENTIVE MAINTENANCE

- B. Clean these surfaces with a disinfectant-detergent then dry with a clean cloth or paper towel.

NOTE: A disinfecting tank is available as an accessory from Air-Shields to facilitate cleaning the rear surface of the Controller. The Controller rear surface is immersed into the tank after filling it with a disinfectant-detergent, then allowing it to soak as recommended by the manufacturer of the cleaning solution.

5. MATTRESS TRAY, AIR CURTAIN COVER, MAIN DECK. Use a disinfectant-detergent to clean all surfaces thoroughly, then dry with a clean cloth or a paper towel.
6. HOOD AND CABINET STAND. Use a disinfectant-detergent to clean all surfaces of the hood thoroughly, including the inner wall and access door heat shield\*. Make sure to clean all holes, indentations, baffles, etc., then dry with a clean cloth or paper towel. Clean the exposed surfaces of the cabinet stand.

CAUTION:

- Alcohol can cause crazing of the clear Plexiglas Hood. Do not use alcohol for cleaning.
  - Do not expose the hood assembly to direct radiation from germicidal lamps. Ultraviolet radiation from these sources can cause cracking of gaskets, fading of paint, and crazing of the clear Plexiglas Hood.
7. AIR-INTAKE MICROFILTER. Do not attempt to clean or reverse the microfilter. If visibly dirty, or older than 3 months, it should be replaced. Before installing a new filter, clean the Microfilter chamber and cover with a disinfectant-detergent.

**WARNING:** A dirty microfilter may affect oxygen concentration and/or cause carbon dioxide buildup. Be sure the filter is checked on a routine basis commensurate with local conditions.

**4.2.3 REASSEMBLY AFTER CLEANING**

After cleaning all parts and assemblies as described in paragraph 4.2.2, reassemble as described below.

1. INSTALL THE AIR INTAKE TUBE (into the Base Assembly) by reversing the procedures shown in Figure 4.5.
2. INSERT HUMIDITY CHAMBER BAFFLE into the Humidity Chamber.

\* Model C100 only. (Optional in C200).

3. INSTALL THE MAIN DECK AND HOOD SEAT GASKET into the Base Assembly as shown in Figure 4.7. Rotate the Main Deck Retainer (Figure 4.4) to secure the deck.
4. INSTALL THE AIR CURTAIN COVER AND MATTRESS TRAY.

**WARNING:** The Air Curtain Cover must be properly installed for correct temperature control

Hook the lip on the bottom of the Air Curtain onto the rod at the rear of the Main Deck Assembly, then lower the cover toward the front of the Incubator to the rest position. Close the Hood Assembly and check for proper operation of the Air Curtain Cover. The Air Curtain Cover is operating correctly if it rises slightly when the Access Panel is opened. Install the Mattress Tray by positioning it a few inches above the mattress rails, then lowering straight down.

5. INSTALL DISPOSABLE MATTRESS COVER. Place a new disposable Mattress Cover over the mattress, then place the mattress onto the tray.

**WRONG MAIN DECK POSITION-**Main deck placed up on gasket on one side, permitting air flow as shown by dashed line.

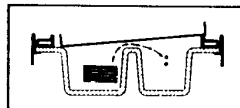

**CORRECT MAIN DECK POSITION-**Main deck placed down on conditioning chamber top.

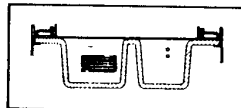

**FIGURE 4.7 INSTALLATION OF MAIN DECK AND HOOD SEAT GASKET**

C100/200  
PREVENTIVE MAINTENANCE

6. INSTALL DISPOSABLE IRIS ENTRY PORT SLEEVES. Install a new Iris Entry Port Sleeve as shown in Figure 4.8.

NOTE: If the Incubator is to be gas sterilized, wait until after sterilization to install new sleeves.



1 Slide the smaller diameter elastic band of new sleeve over the inner ring of the port housing.



2 Fold back and slip larger elastic band over the outer ring of the port housing.

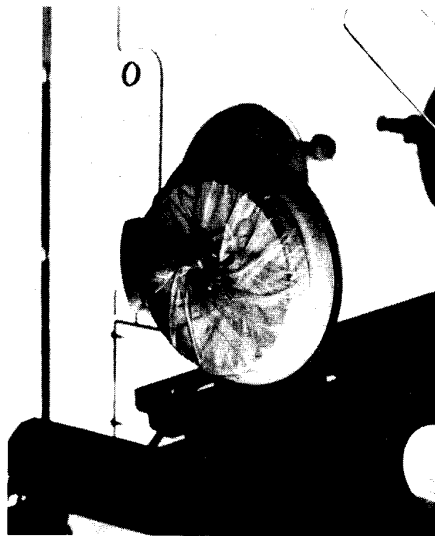

3 Rotate outer ring to close. If properly installed, the sleeve will open again if rotation is reversed.

**FIGURE 4.8 INSTALLATION OF IRIS ENTRY PORT SLEEVE**



7. INSTALL A TUBING ACCESS PORT into the front edge of each side of the Hood. Replace if distorted or torn.
8. INSTALL AN ACCESS DOOR GASKET behind each Access Door, as shown in Figure 4.9.

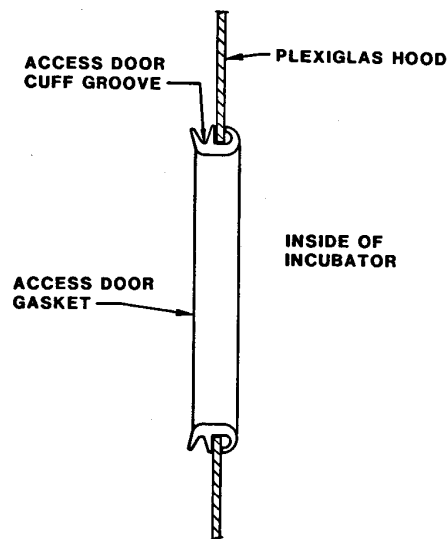

**FIGURE 4.9 INSTALLATION OF ACCESS DOOR GASKET**

9. INSTALL A NEW ACCESS DOOR CUFF onto each Access Door Gasket by stretching the larger diameter elastic band into the groove in the gasket. When installed correctly, the cuff has a small opening at its center. The Access Door should latch with slight pressure, and should open when the latch button is depressed.

**NOTE:** If the Incubator is to be gas sterilized, wait until after sterilization to install new sleeves.

10. INSTALL HOOD INNER WALL by reversing the procedure shown in Figure 4.2.
11. INSTALL THE HEAT SHIELD onto the Access Panel.

C100/200  
PREVENTIVE MAINTENANCE

12. INSTALL A NEW AIR-INTAKE MICROFILTER if necessary. Replace the Air Intake Microfilter Cover and tighten the two thumbscrews. If a new filter is installed, indicate the date on the place provided on the cover.

IMPORTANT: A complete operational checkout (paragraph 2.4) should be performed before returning the unit to service.

#### 4.3 GAS STERILIZATION

Prior to gas sterilization, the entire Incubator should be thoroughly cleaned as described elsewhere in this section. All used disposable elements such as iris sleeves, access door cuffs, mattress covers, etc., should be removed and discarded as described in the cleaning instructions. New disposable elements should be installed after sterilization.

Release the Controller latches and slide the unit out about 1/4". The Access Panel may be closed, but the Access Doors should be left open. The Air Intake Microfilter may be left in place.

NOTE: Gas sterilization does not eliminate the need for routine replacement of the Air Intake Microfilter.

CAUTION: Sterilization temperature should not exceed 130°F (54.5C).

Standard Gas sterilization procedures as programmed by automatic equipment such as made by American Sterilizers and Wilmot Castle are satisfactory as these do not normally exceed 130°F (54.5C).

Upon completion of gas sterilization, an aeration period of 16 to 24 hours should be allowed. The Control unit should be properly secured in place and the C100 Incubator should be operated in a dry condition for the entire period of aeration at a temperature of 32 to 35°C. After aeration, if the unit is not to be used immediately, a disposable dust cover should be placed on the Incubator.

IMPORTANT: A complete operational checkout procedure (paragraph 2.4) should be performed before returning the unit to service.

#### 4.4 CALIBRATION SCHEDULE

It is recommended that the Controller of the Incubator be tested and calibrated at least every four to six months and after repairs have been made. Calibration and test procedures are provided in Section 5 of this manual.

## SECTION 5 SERVICE

### 5.1 GENERAL

This section provides calibration, troubleshooting, and removal and replacement instructions for the Model C100 and C200 Incubators.

IMPORTANT: It should be noted that the terms "SET TEMP" and "SET POINT" are used interchangeably in this manual.

### 5.2 CALIBRATION PROCEDURES

#### 5.2.1 GENERAL

This paragraph provides calibration procedures for the Controllers and tests for the Incubator.

Unless otherwise indicated, all calibration procedures are performed under the following conditions:

1. The Controller is removed from the Incubator and the cover is removed.
2. The Controller is connected to a primary source of the correct voltage and frequency.

#### 5.2.2 TEST EQUIPMENT REQUIRED

The test equipment listed below is required for calibration of the Controller and performing Oxygen Concentration tests. Equivalent test equipment may be substituted.

- Probe Simulator, Part No. 68 900 80 - # 373 100
- Logic Probe - capable of  $\pm 12$  Vdc
- Variable Transformer, General Radio Model WSM T3AW
- Digital VOM, Fluke Model 8000A
- Oxygen Analyzer, Sybron/Taylor Model QA580
- Flowmeter, Victor - Model 1099-0025
- Leakage Tester, Bo-Tek 501

C100/200  
SERVICE

**5.2.3 PCB2 - MODEL C100**

TEST SETUP.

1. Connect the Simulator to the PATIENT PROBE and AUXILIARY PROBE jacks on the Side Panel of the Controller. Connect the ac line cord through a variac and turn on the unit. Set the variac as follows:  $120 \pm 2 V \sim$  (110/120V Models);  $240 \pm 2V \sim$  (220/240V Models);  $100 \pm 2V \sim$  (100V Models).
2. On the Controller, set the AIR and SKIN set Temp. switches to  $36.0^{\circ}\text{C}$ . Set the CONTROL MODE switch to AIR.
3. On the Simulator, set the MODE switch to AIR and the TEMP switch to  $36^{\circ}\text{C}$ . Refer to Figure 5.1 for location of test points and adjustments.

PROCEDURE

1. Refer to Figure 5.1 and connect the DVM between TP20 (+) and TP22 on PCB2.
2. Adjust R35 on PCB2 for a reading of  $-350 \pm 50 \text{ mV}$  on the DVM.
3. On the Simulator, set the MODE switch to SKIN. Connect the DVM between TP13 (+) and TP22.
4. Adjust R50 for a reading of  $-350 \pm 50 \text{ mV}$  on the DVM.
5. Turn off the POWER switch on the Controller. Connect the logic probe between +12 Vdc and ground. Monitor TP15 with the logic probe.
6. Turn the unit on. Set the variac as follows:  $95 \pm 2V \sim$  (110/120V Models);  $190 \pm 2V \sim$  (220/240V Models);  $80 \pm 2V \sim$  (100V Models). The light on the logic probe should flash on and off every four seconds.
7. Slowly turn R100 clockwise until the light momentarily goes out approximately every four seconds. If the light stays on constantly, back off (counterclockwise) R100 slightly.
8. Set the variac as follows:  $120 \pm 2V \sim$  (110/120V Models);  $240 \pm 2V \sim$  (220/240V Models);  $100 \pm 2V \sim$  (100V Models). The light should go off for approximately 2 seconds and come on for approximately four seconds.
9. Turn off the Power. Remove the logic probe.

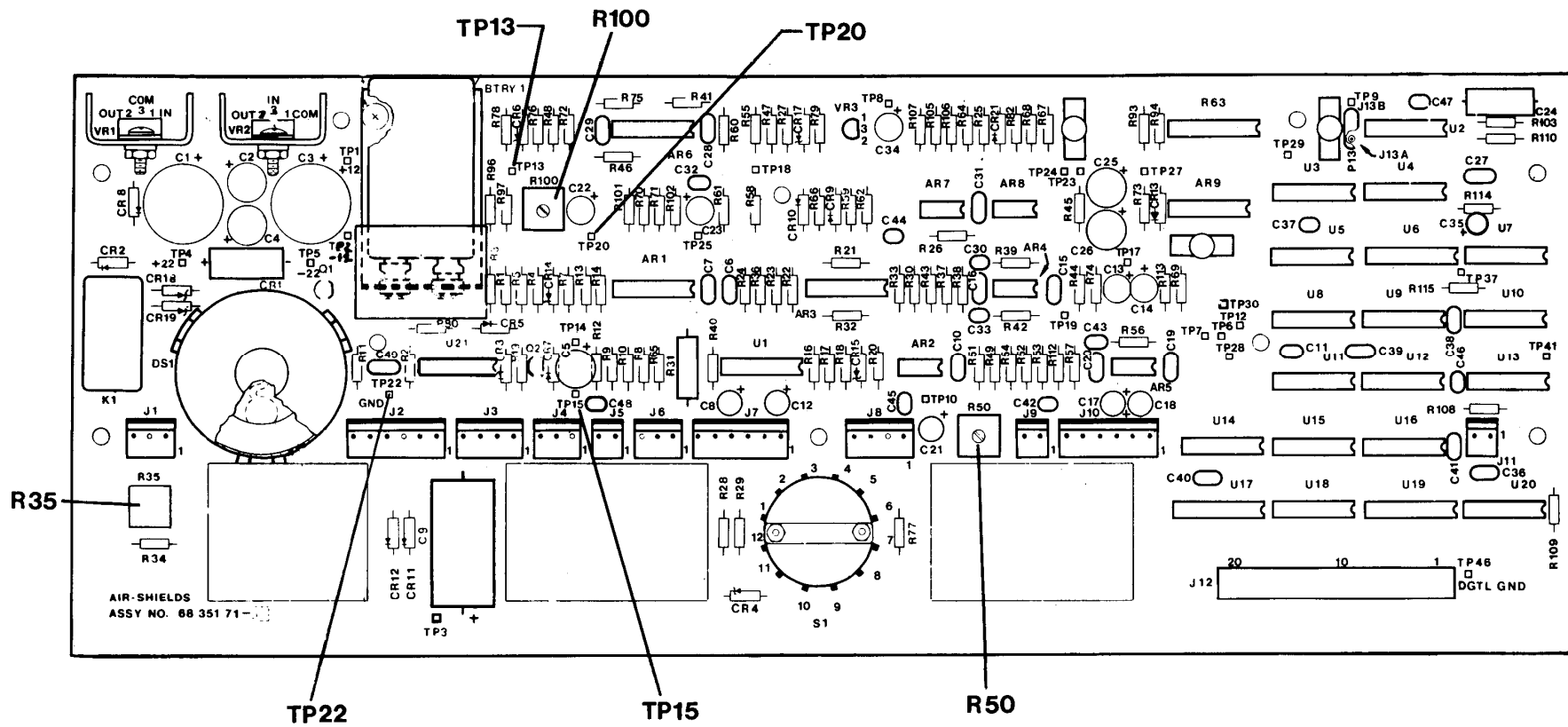

FIGURE 5.1 PCB2 (MODEL C100), LOCATION OF TEST POINTS AND ADJUSTMENTS

C100/200  
SERVICE

**5.2.4 PCB1 – MODEL C100**

TEST SETUP.

1. Remove the CONTROL MODE knob. Remove the five screws which hold PCB1 and PCB2 to the Front Panel. Set PCB1 and PCB2 vertically behind the brackets located behind the SILENCE/RESET and POWER switches.
2. Connect the Simulator to the PATIENT PROBE and AUXILIARY PROBE jacks on the Side Panel. Set the Simulator to 36°C. Set the Controller and Simulator to SKIN mode. Refer to Figure 5.2. for location of test points and adjustments.

PROCEDURE.

1. On PCB1, adjust R7 until the left display (SKIN) reads 36.0 ± 0.1°C.
2. Set the Simulator to 20°C. Adjust R2 on PCB1 until the left display (SKIN) reads 20.0 ± 0.1°C.
3. Repeat steps 1 and 2 to ensure proper settings. Readjust if necessary.
4. Set the Simulator to AIR mode and 36.0°C.
5. On PCB1 adjust R18 until the right display (AIR) reads 36 ± 0.1°C.
6. Set the Simulator to 20°C. On PCB1 adjust R13 until the right display (AIR) reads 20 ± 0.1°C.
7. Repeat steps 5 and 6 to ensure proper settings. Readjust if necessary.

**5.2.5 PCB2 – MODEL C200**

TEST SETUP.

1. Connect the Simulator to the AUXILIARY PROBE jack on the Side Panel of the Controller. Connect the ac line cord through a variac and turn on the unit. Set the variac as follows: 120 ± 2V~ (110/120V Models); 240 ± 2V~ (220/240V Models); 100 ± 2V~ (100V Models).
2. On the Controller, set the SET TEMP °C switch to 36.0°C.
3. On the Simulator, set the MODE switch to AIR and the TEMP switch to 36°C. Refer to Figure 5.3 for location of test points and adjustments.

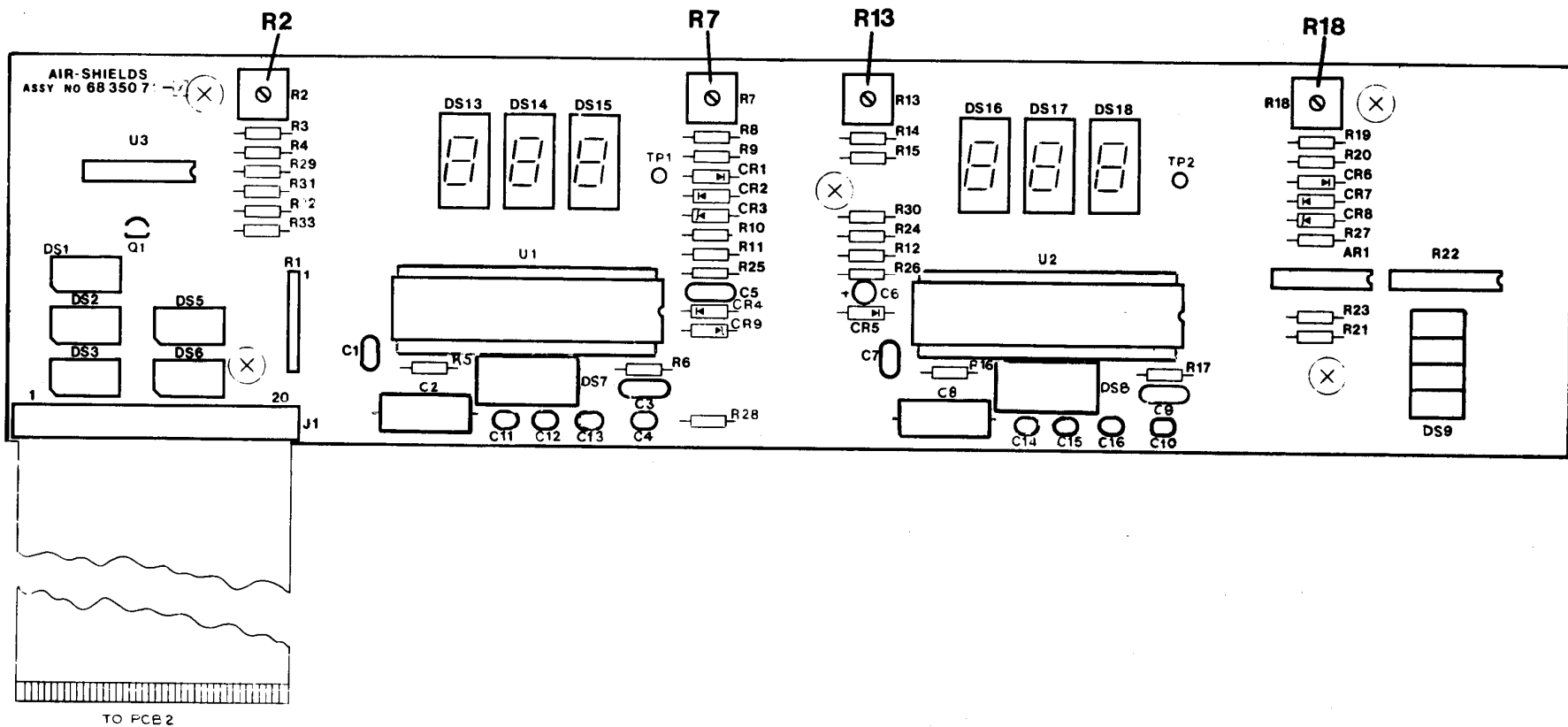

FIGURE 5.2 PCB1 (MODEL C100), LOCATION OF TEST POINTS AND ADJUSTMENTS

C100/200  
SERVICE

PROCEDURE.

1. Refer to Figure 5.3 and connect the DVM between TP20 (+) and TP22 on PCB2.
2. Adjust R35 on PCB2 for a reading of  $-350 \pm 50\text{mV}$  on the DVM.
3. Turn off the POWER switch on the Controller. Connect the logic probe between +12 Vdc and ground. Monitor TP15 with the logic probe.
4. Turn the unit on. Set the variac as follows:  $95 \pm 2\text{V} \sim$  (110/120V Models);  $190 \pm 2\text{V} \sim$  (220/240V Models);  $80 \pm 2\text{V} \sim$  (100V Models). On PCB2 turn R100 fully counterclockwise. The light on the logic probe should flash on and off every four seconds.
5. Slowly turn R100 clockwise until the light momentarily goes out approximately every four seconds. If the light stays on constantly, back off (counterclockwise) R100 slightly.
6. Set the variac as follows:  $120 \pm 2\text{V} \sim$  (110/120V Models);  $240 \pm 2\text{V} \sim$  (220/240V Models);  $100 \pm 2\text{V} \sim$  (100V Models). The light should go off for approximately 2 seconds and come on for approximately 4 seconds.
7. Turn off the power. Remove the logic probe.

**5.2.6 PCB1 – MODEL C200**

TEST SETUP.

1. Remove the five screws which hold PCB1 and PCB2 to the Front Panel. Set PCB1 and PCB2 vertically behind the brackets located behind the SILENCE/RESET and POWER switches.
2. Connect the Simulator to the AUXILIARY PROBE jack on the Side Panel. Set the Simulator to  $36^\circ\text{C}$ . Set the Simulator to AIR mode. Refer to Figure 5.4 for location of test points and adjustments.

PROCEDURE

1. On PCB1 adjust R18 until the display reads  $36 \pm 0.1^\circ\text{C}$ .
2. Set the Simulator to  $20^\circ\text{C}$ . On PCB1 adjust R13 until the display reads  $20 \pm 0.1^\circ\text{C}$ .
3. Repeat steps 1 and 2 to ensure proper settings. Readjust if necessary.
4. Reassemble the Controller and disconnect the Simulator.



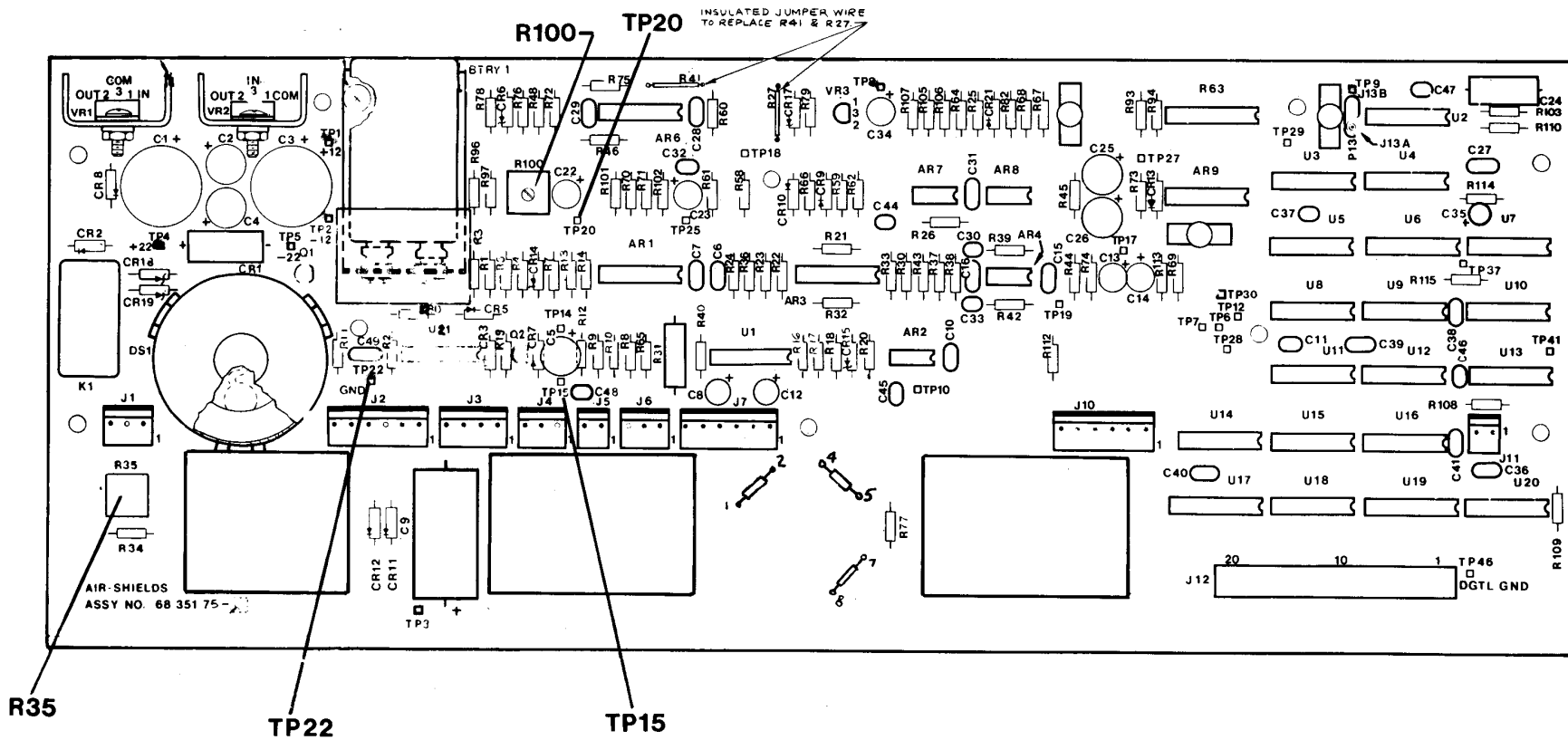

5-7

FIGURE 5.3 PCB2 (MODEL C200), LOCATION OF TEST POINTS AND ADJUSTMENTS

C100/200  
SERVICE

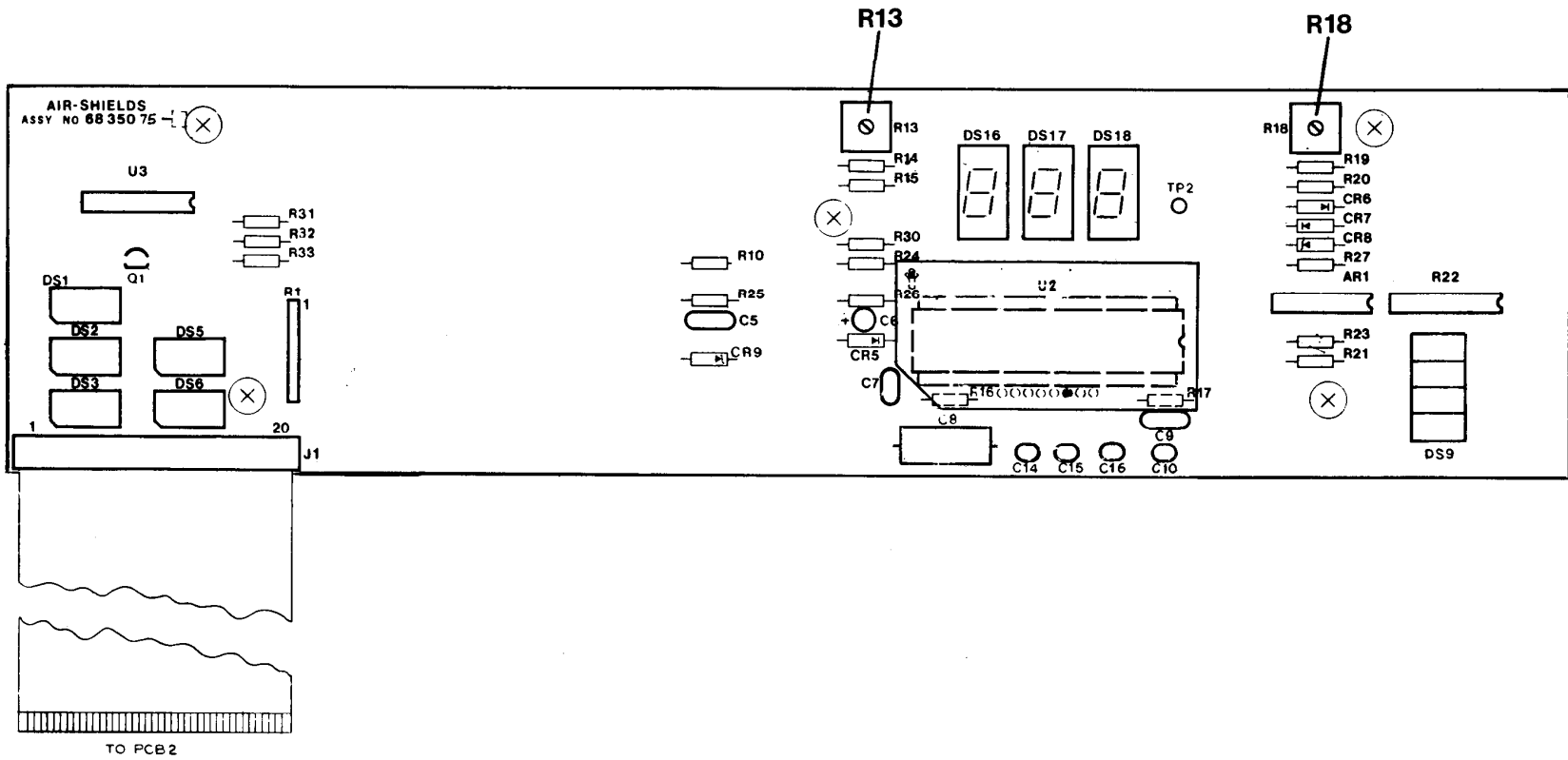

FIGURE 5.4 PCB1 (MODEL C200), LOCATION OF TEST POINTS AND ADJUSTMENTS

### **5.2.7 LEAKAGE CURRENT TESTS**

#### TEST SETUP.

1. Connect the Controller to the primary power source through an ungrounded adapter plug, so that the unit is ungrounded. Turn the POWER switch on.
2. The leakage current test standards provided in the procedure below assume leakage through a resistance of 1000 ohms. If the Leakage Tester being used does not provide this resistance, the test set-up must be adjusted to provide it.

#### PROCEDURE.

1. Use the Leakage Tester to measure between the chassis of the unit under test and a known ground such as the ground connection of a wall receptacle. The leakage current must not exceed 100 microamps.
2. Reverse the plug and repeat step 1.
3. Perform steps 1 and 2 with the Controller POWER switch OFF.

### **5.2.8 OXYGEN CONCENTRATION TESTS**

#### TEST SETUP.

1. Place a calibrated oxygen analyzer on the mattress in the Incubator.
2. Apply oxygen at a flowrate of 8 LPM to the O<sub>2</sub> nipple on the Filter Cover.

#### PROCEDURE

1. Turn the unit ON.
2. After 40 minutes of operation, verify that the oxygen concentration level is between 37% and 40% for 60 Hz units and 42% and 47% for 50 Hz units.
3. Increase the Oxygen flow to 12 LPM. After another 40 minutes of operation, verify that the oxygen concentration level is between 70% and 95% for 60 Hz units and 70% and 95% for 50 Hz units.

### 5.3 TROUBLESHOOTING

#### 5.3.1 GENERAL

Troubleshooting guides for the Incubators and the Controllers are presented under paragraph 5.3.3 in the form of flowcharts. It is assumed that an attempt has been made to calibrate the unit and that all cables are in good condition.

#### 5.3.2 TEST EQUIPMENT REQUIRED

The test equipment listed below is required for troubleshooting the Controller of the Incubator. Equivalent test equipment may be substituted.

- Digital Voltmeter, Fluke Model 8000A
- Logic Probe - capable of  $\pm 12$  Vdc
- Oscilloscope, Tektronix Model T912
- Probe Simulator, Part No. 68 900 80
- Variable Transformer, General Radio Model WSM T3AW
- Resistor, 3.6 K, 1/4 Watt, 5%
- Resistor, 4.6 K, 1/4 Watt, 5%
- Resistor, 390 Ohms, 1/4 Watt, 5%
- Resistor, 100 Ohms, 1/4 Watt, 5%
- Oxygen Analyzer
- Flowmeter

#### 5.3.3 TROUBLESHOOTING PROCEDURES

Unless otherwise specified on the troubleshooting charts, all checks are made with the Controller plugged into an ac power source and the POWER switch is on. The troubleshooting charts assume that the calibration procedures described in paragraph 5.2 have been attempted. Flowcharts 5-14 and 5-15 assume that the Controller is in the Incubator.

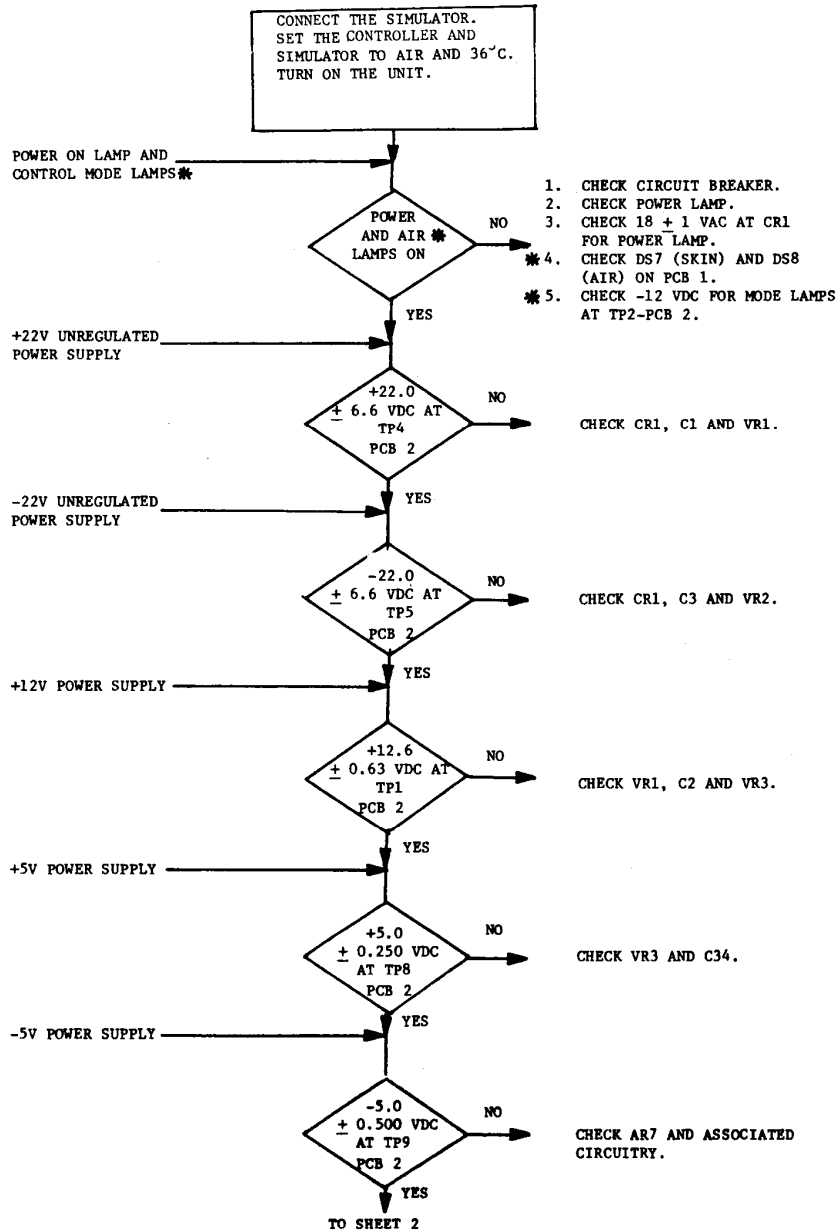

\* MODEL C100 ONLY

FLOWCHART 5.1 OVERALL CHECKS (SHEET 1 of 8)

C100/200  
SERVICE

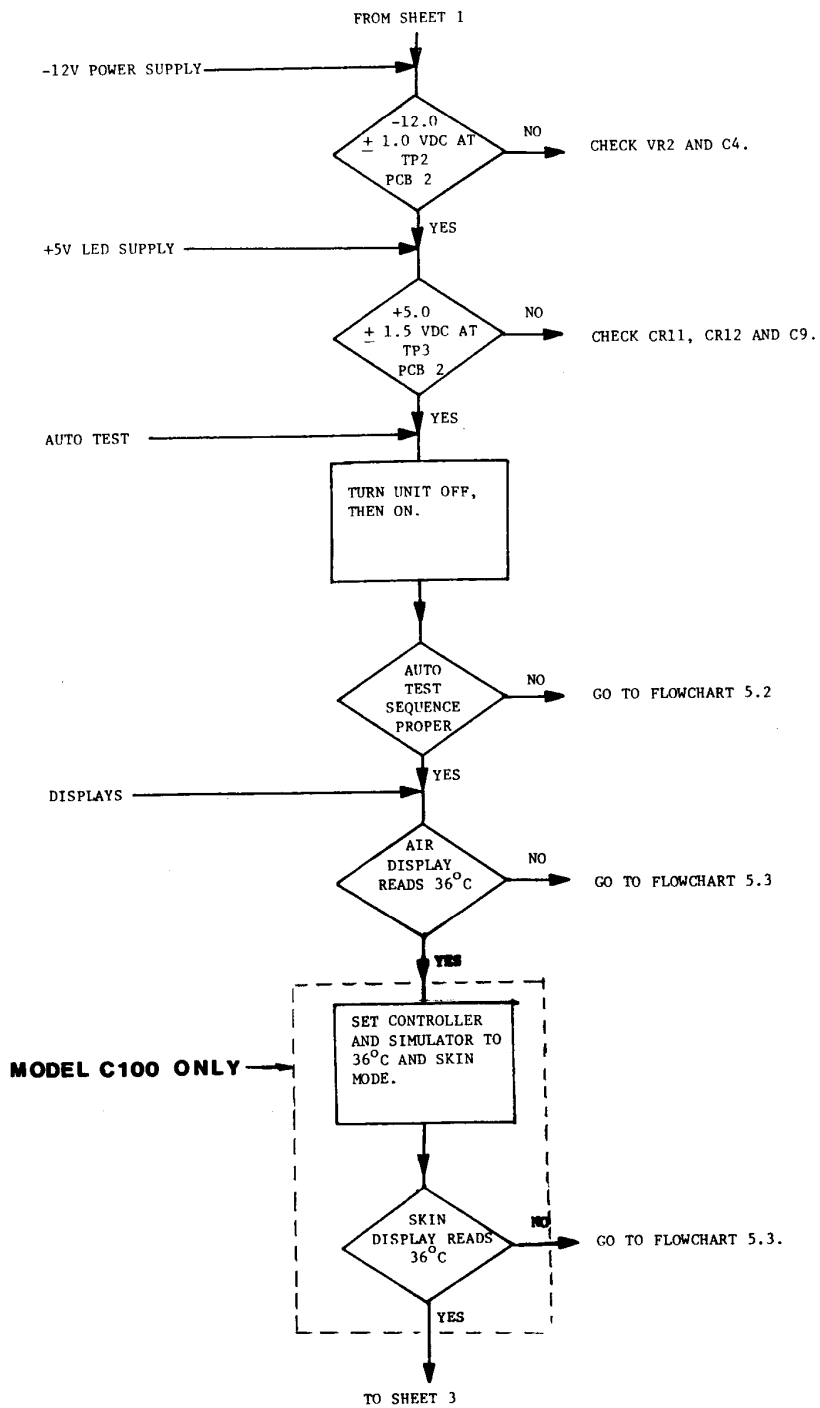

FLOWCHART 5.1 OVERALL CHECKS (SHEET 2 of 8)

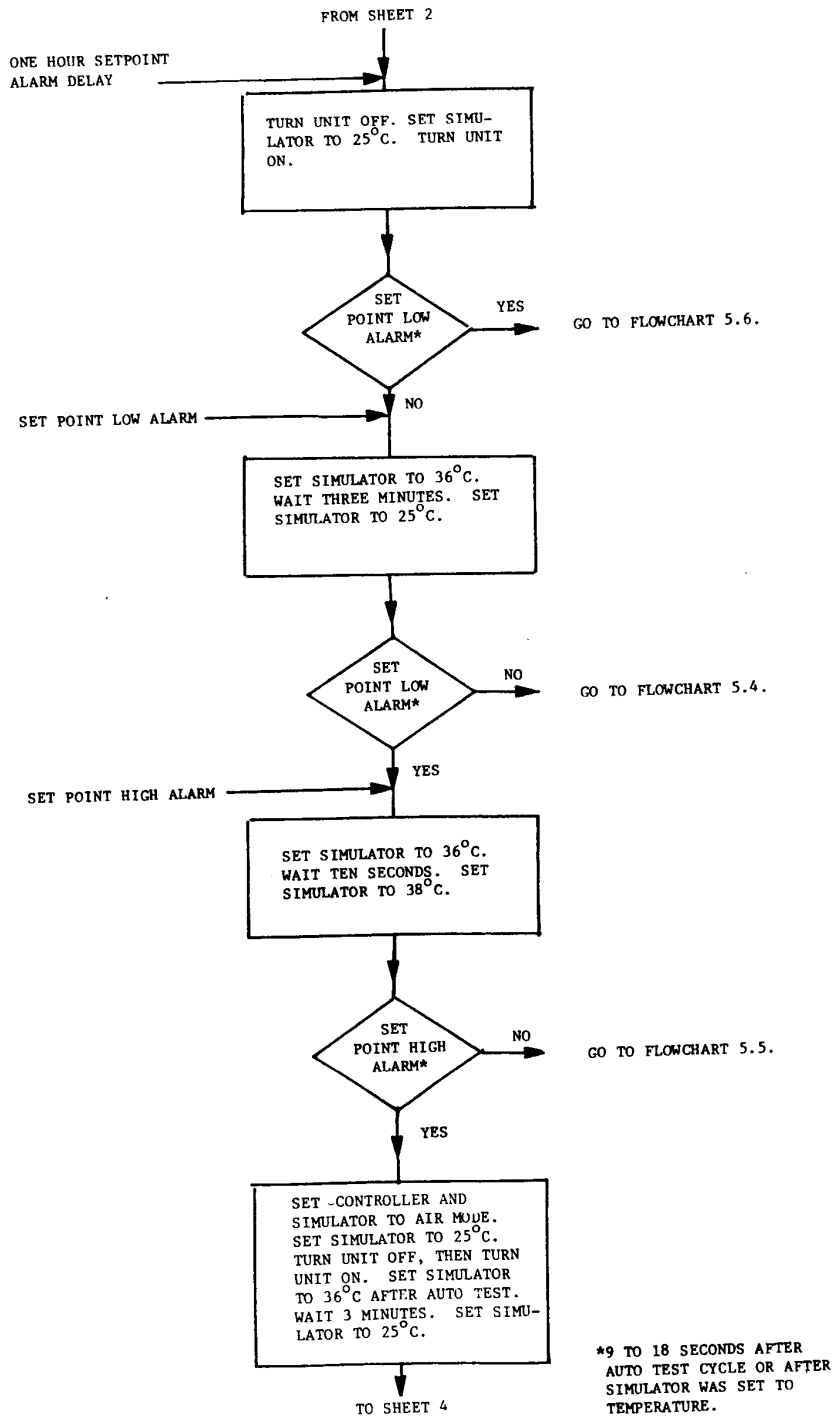

FLOWCHART 5.1 OVERALL CHECKS (SHEET 3 of 8)

C100/200  
SERVICE

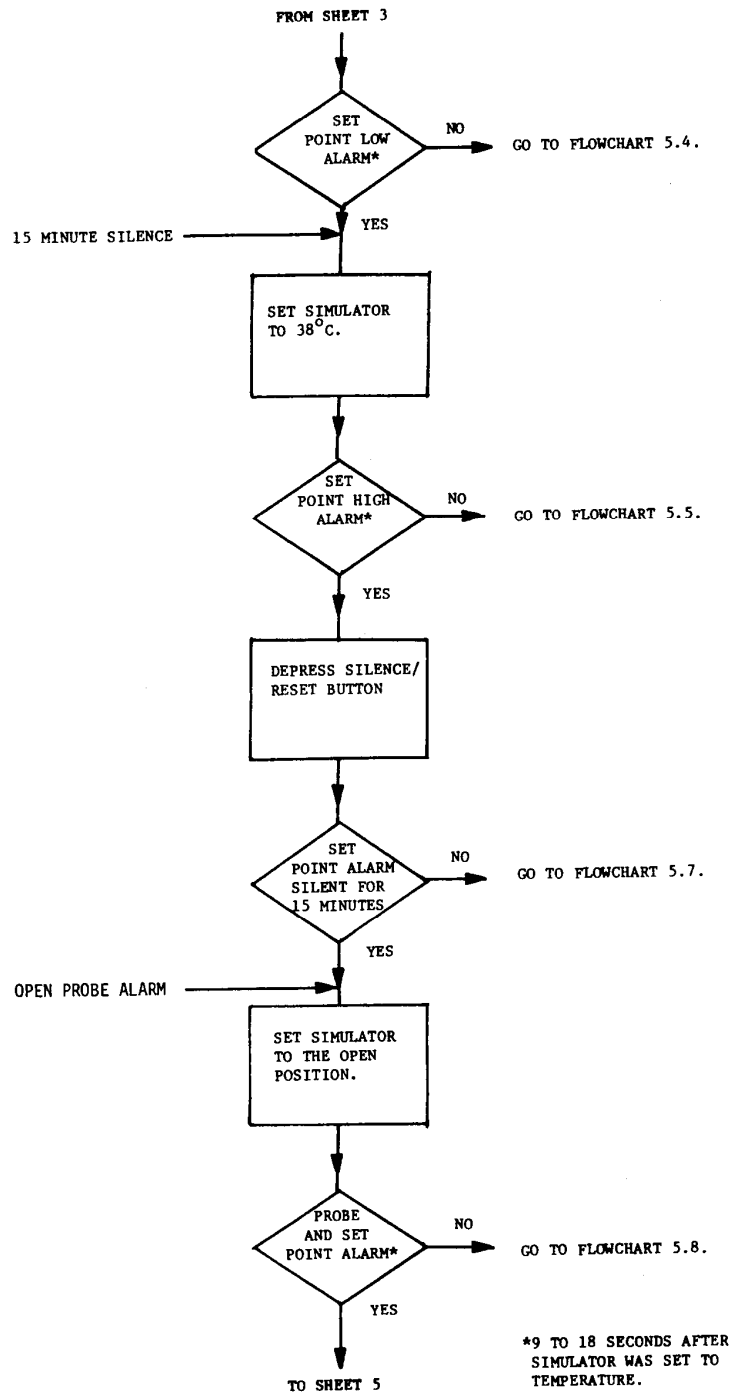

FLOWCHART 5.1 OVERALL CHECKS (SHEET 4 of 8)



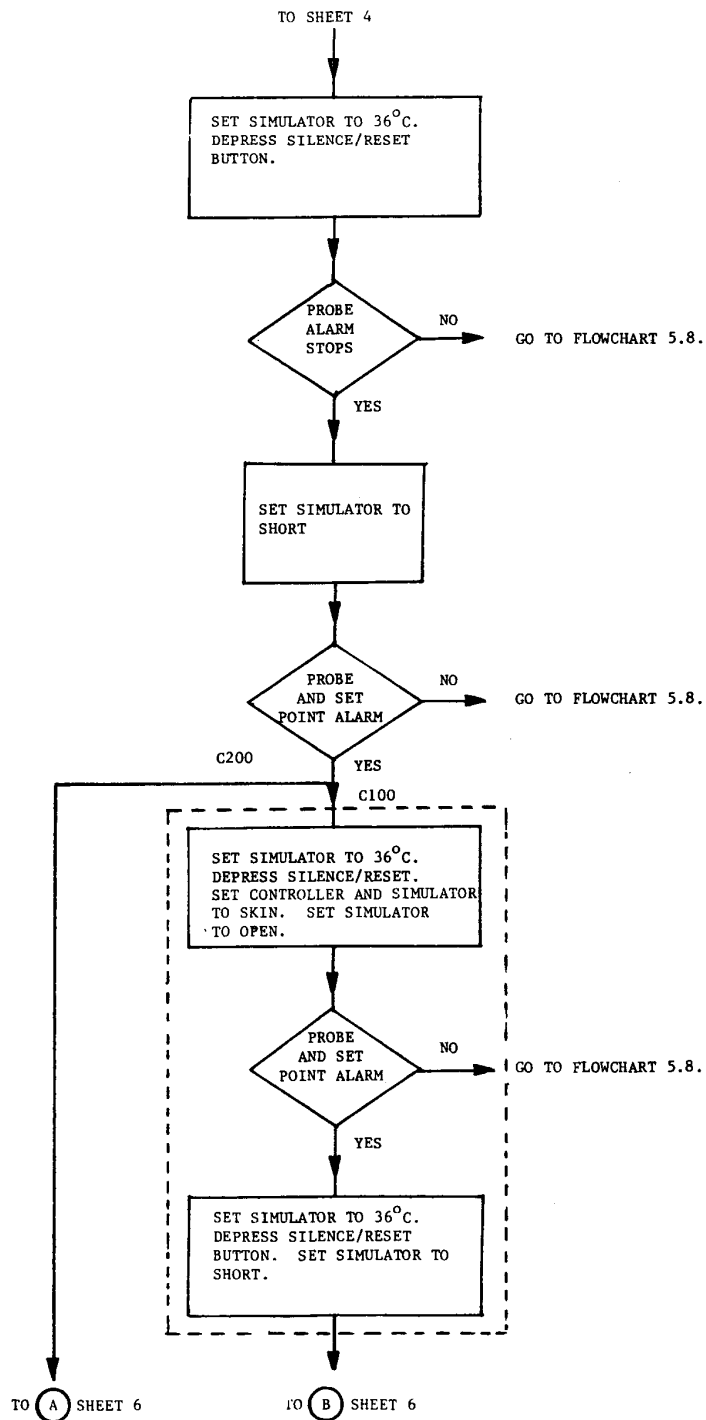

FLOWCHART 5.1 OVERALL CHECKS (SHEET 5 of 8)

C100/200  
SERVICE

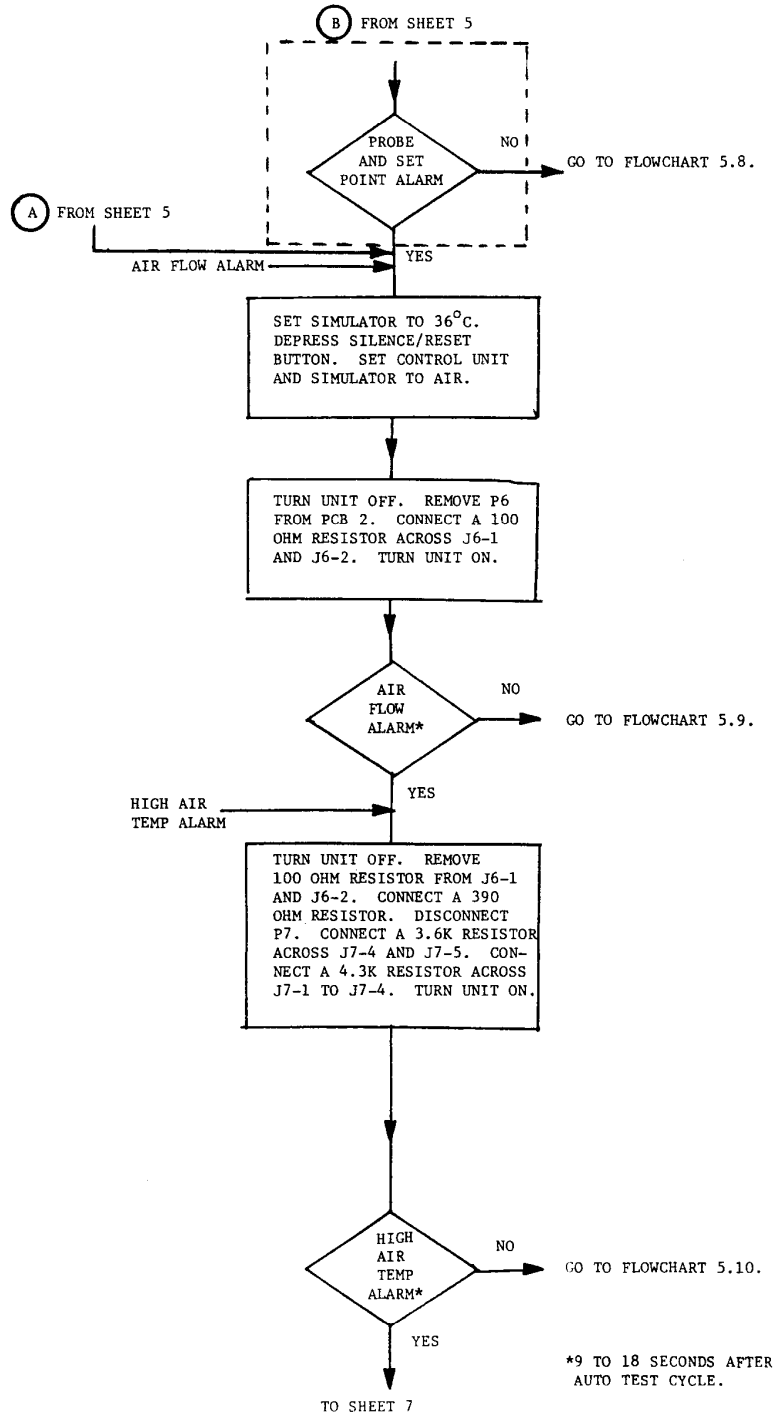

FLOWCHART 5.1 OVERALL CHECKS (SHEET 6 of 8)

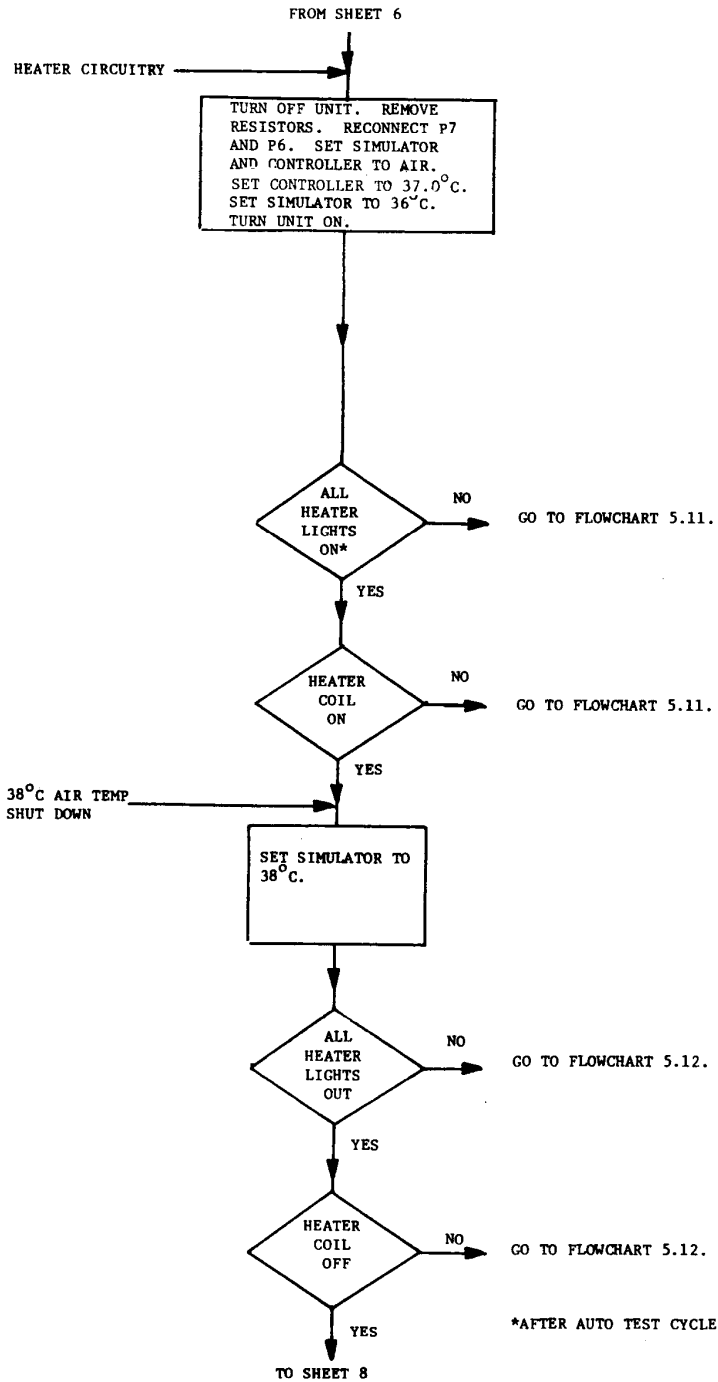

FLOWCHART 5.1 OVERALL CHECKS (SHEET 7 of 8)

C100/200  
SERVICE

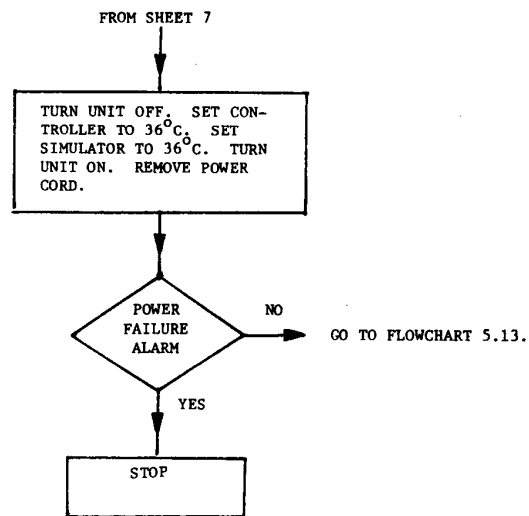

**FLOWCHART 5.1 OVERALL CHECKS (SHEET 8 of 8)**

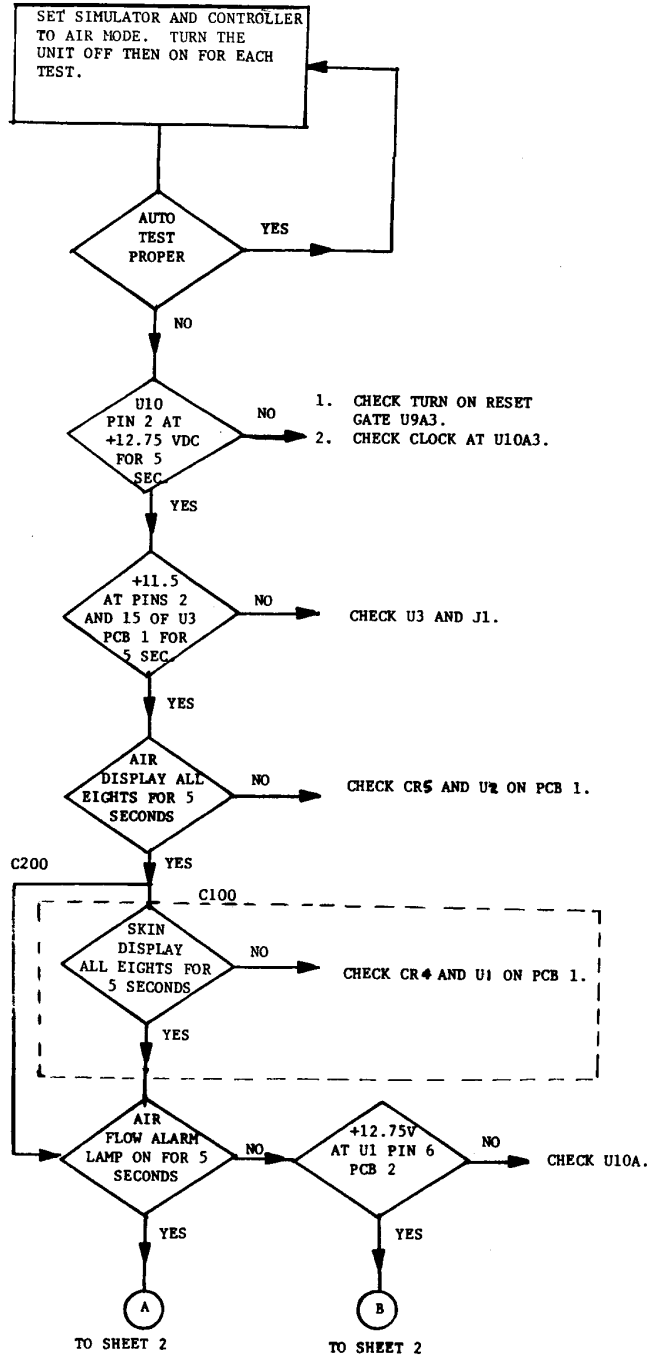

FLOWCHART 5.2 AUTO TEST TROUBLESHOOTING (SHEET 1 of 3)

C100/200  
SERVICE

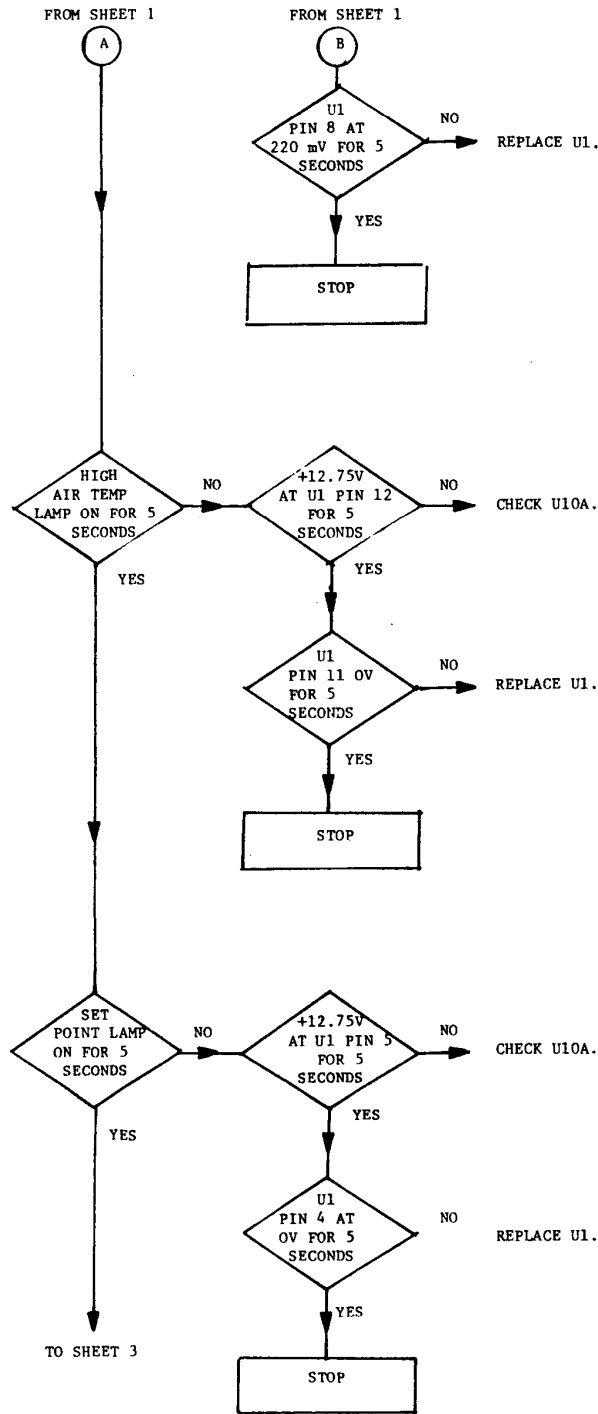

FLOWCHART 5.2 AUTO TEST TROUBLESHOOTING (SHEET 2 of 3)

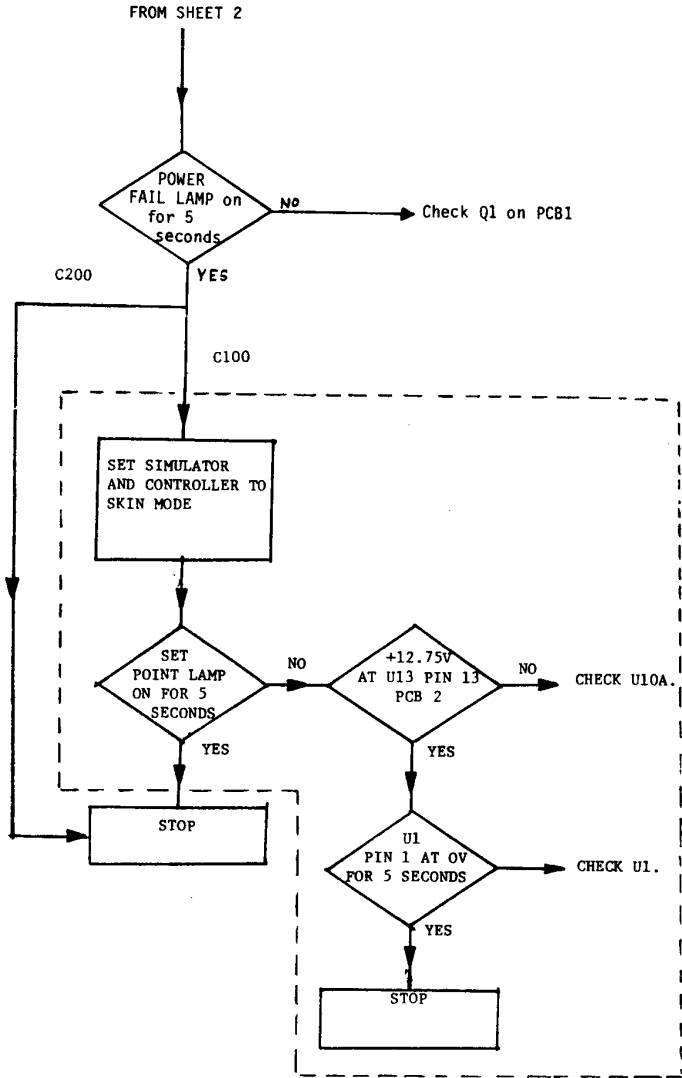

FLOWCHART 5.2 AUTO TEST TROUBLESHOOTING (SHEET 3 of 3)

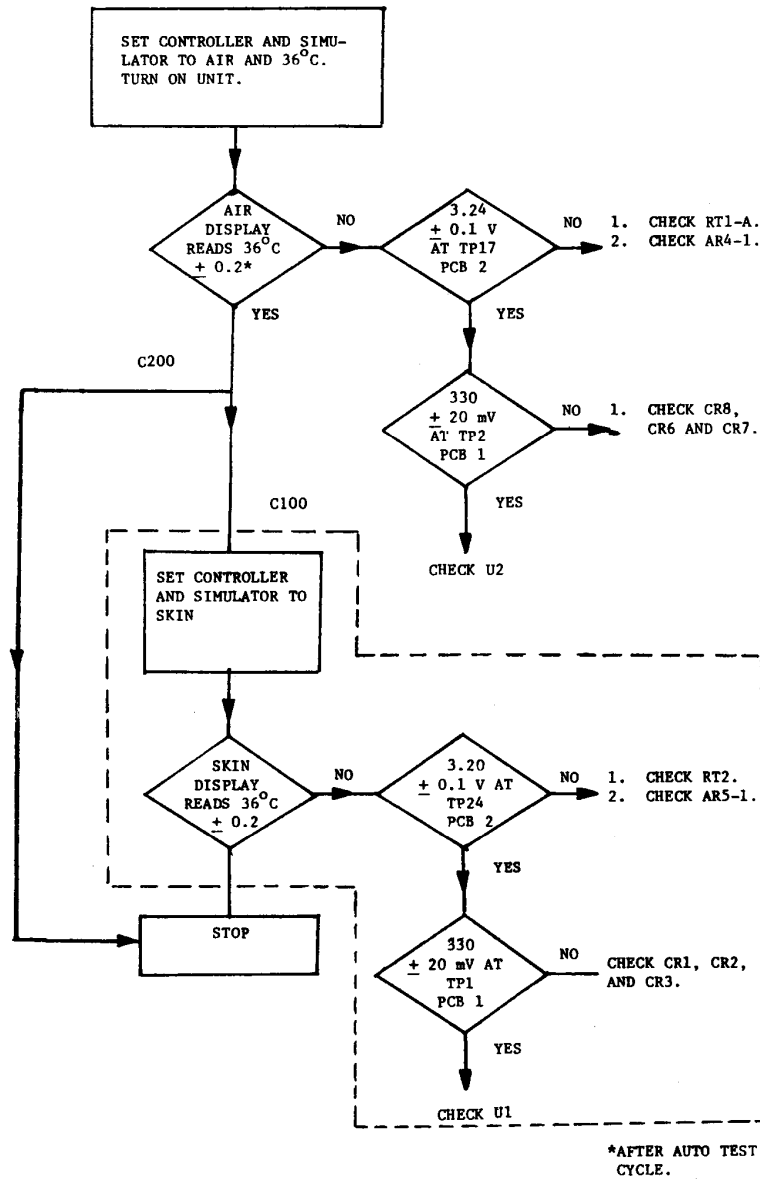

FLOWCHART 5.3 DISPLAY TROUBLESHOOTING



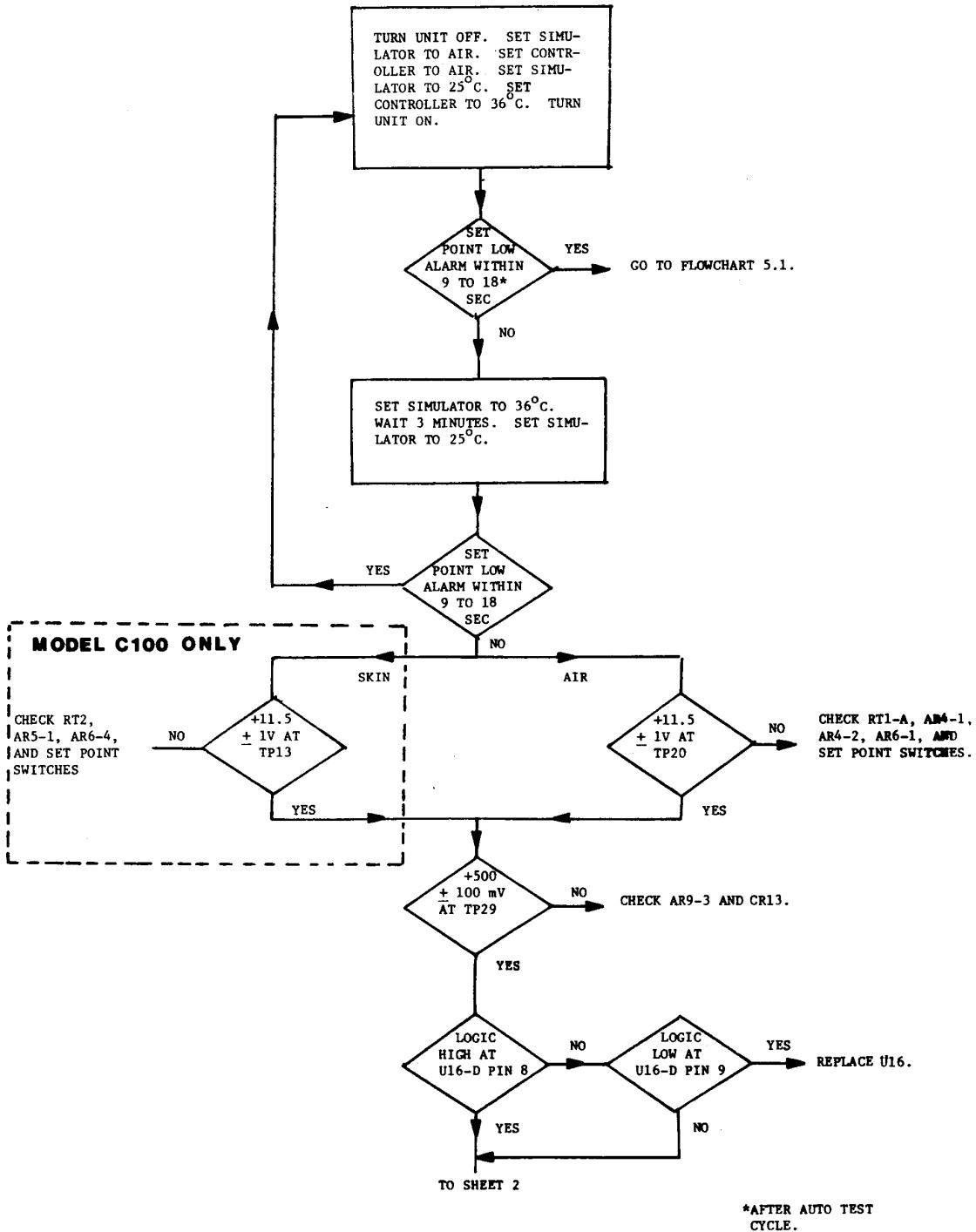

FLOWCHART 5.4 SET POINT LOW ALARM TROUBLESHOOTING (SHEET 1 of 3)

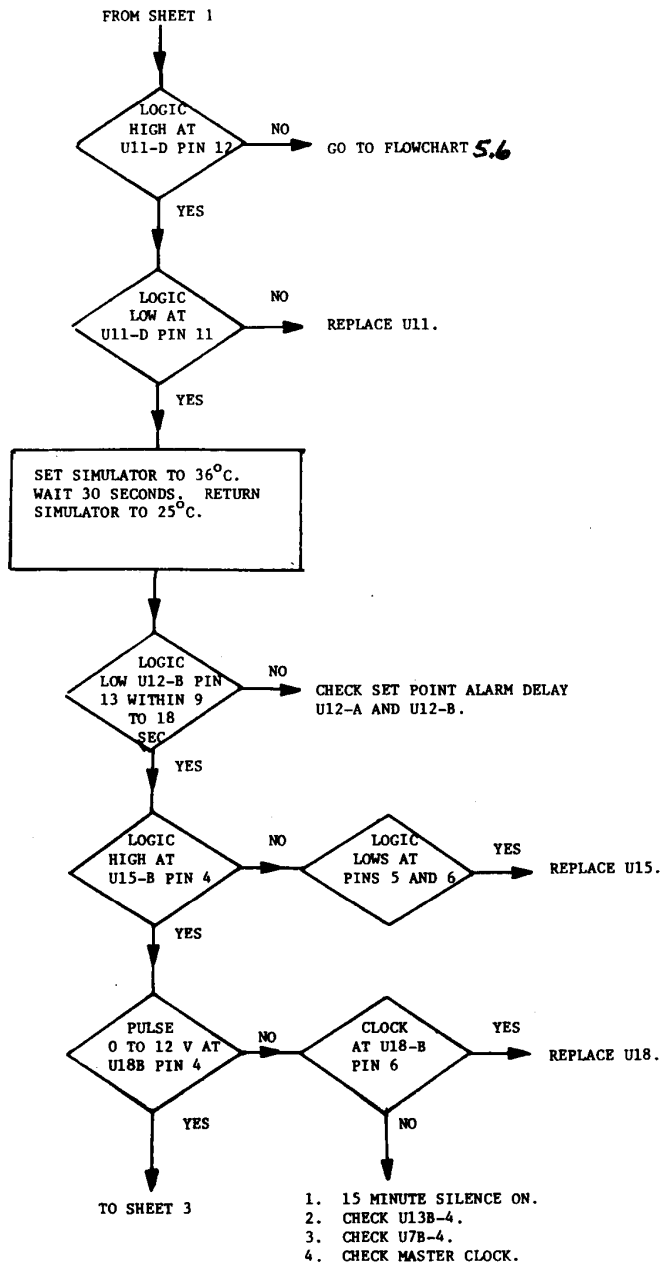

**FLOWCHART 5.4 SET POINT LOW ALARM TROUBLESHOOTING (SHEET 2 of 3)**

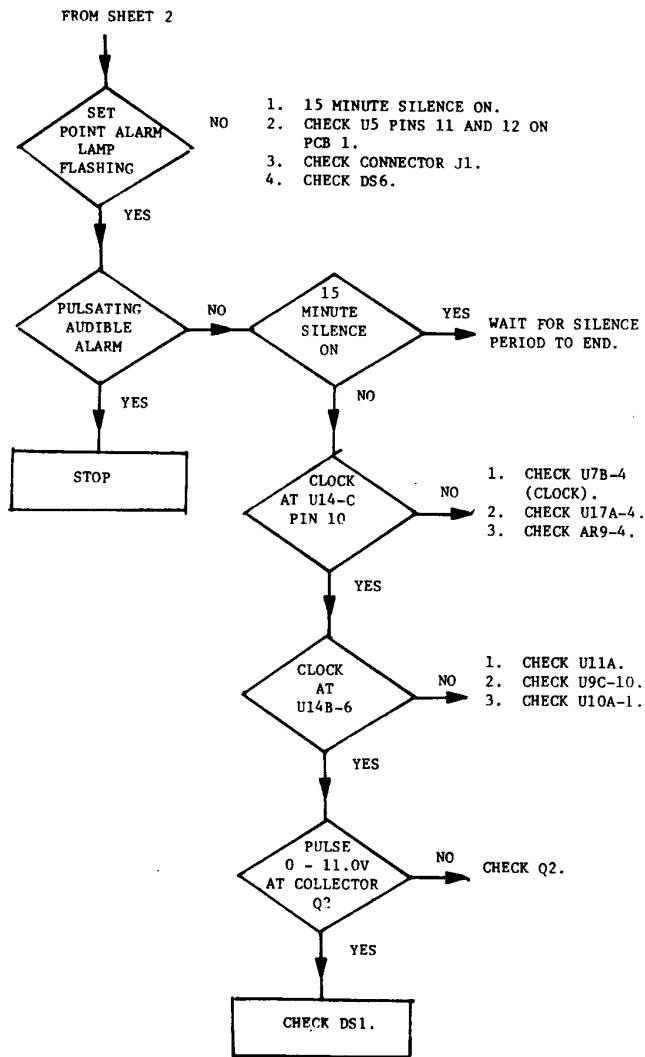

FLOWCHART 5.4 SET POINT LOW ALARM TROUBLESHOOTING (SHEET 3 of 3)

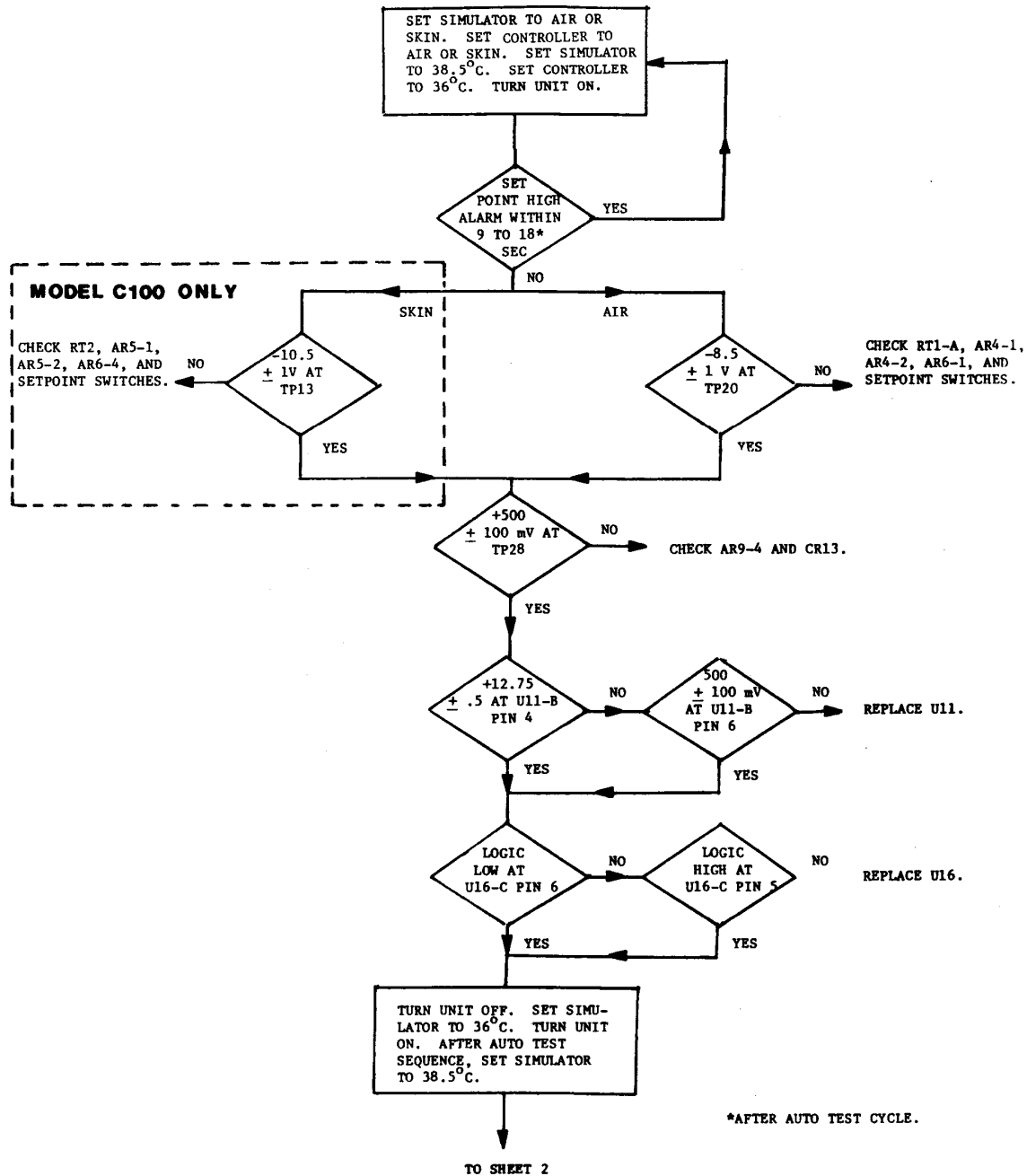

FLOWCHART 5.5 SET POINT HIGH ALARM TROUBLESHOOTING (SHEET 1 of 3)

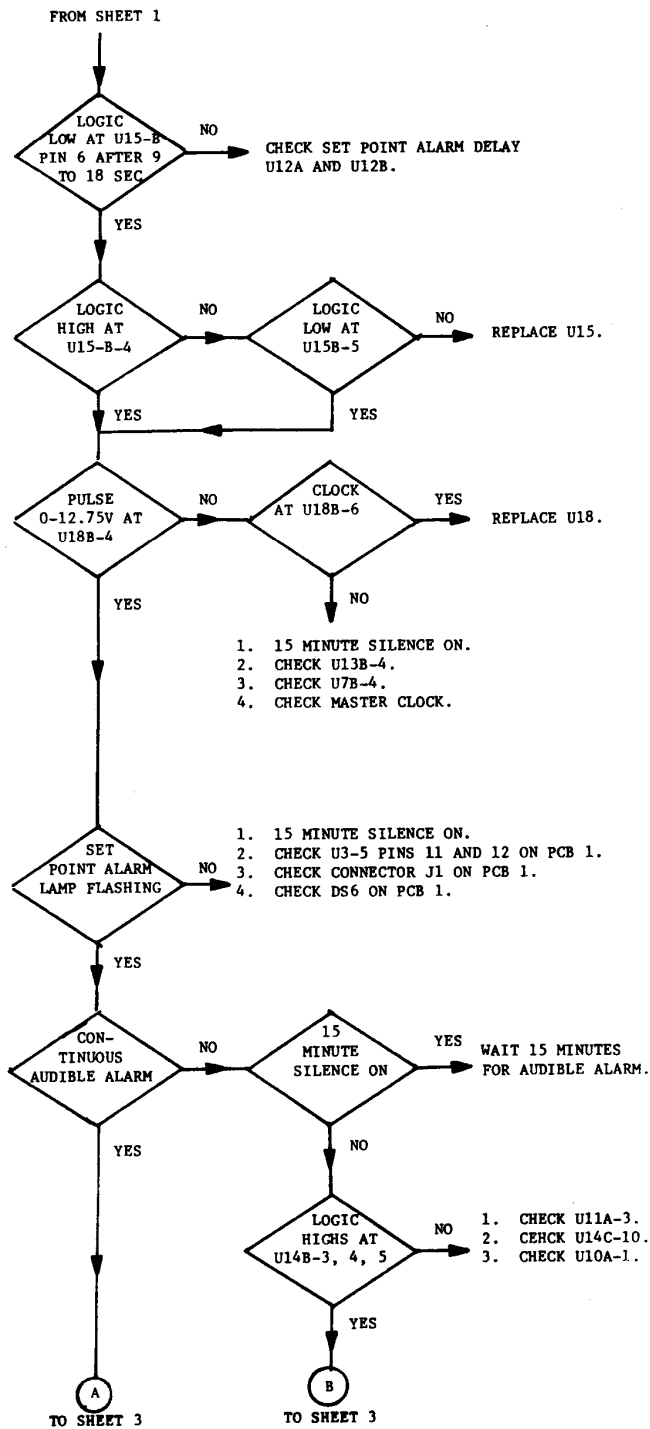

FLOWCHART 5.5 SET POINT HIGH ALARM TROUBLESHOOTING (SHEET 2 of 3)

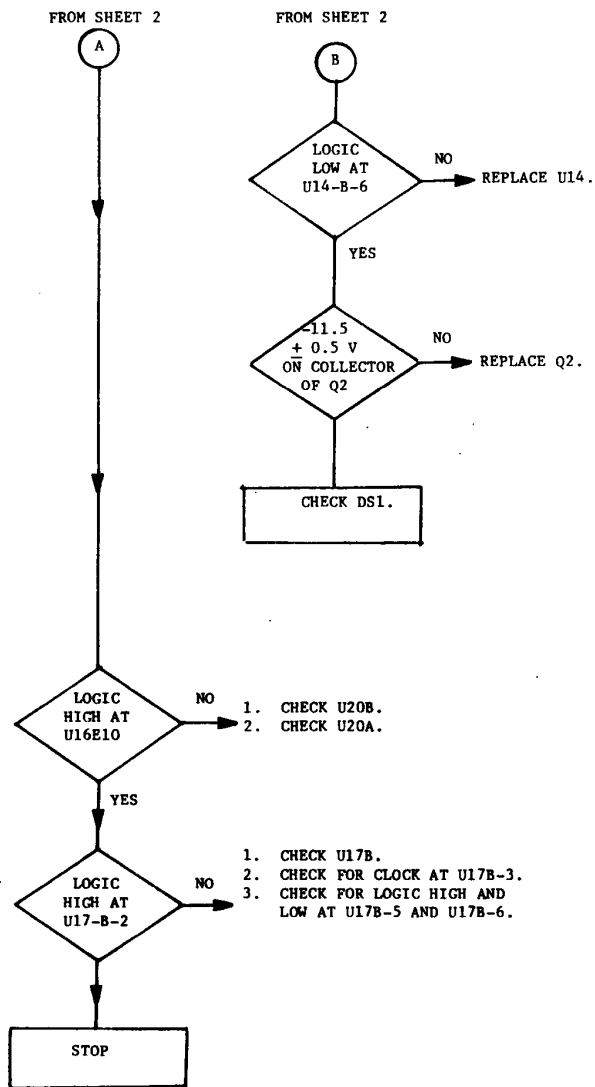

**FLOWCHART 5.5 SET POINT HIGH ALARM TROUBLESHOOTING (SHEET 3 of 3)**

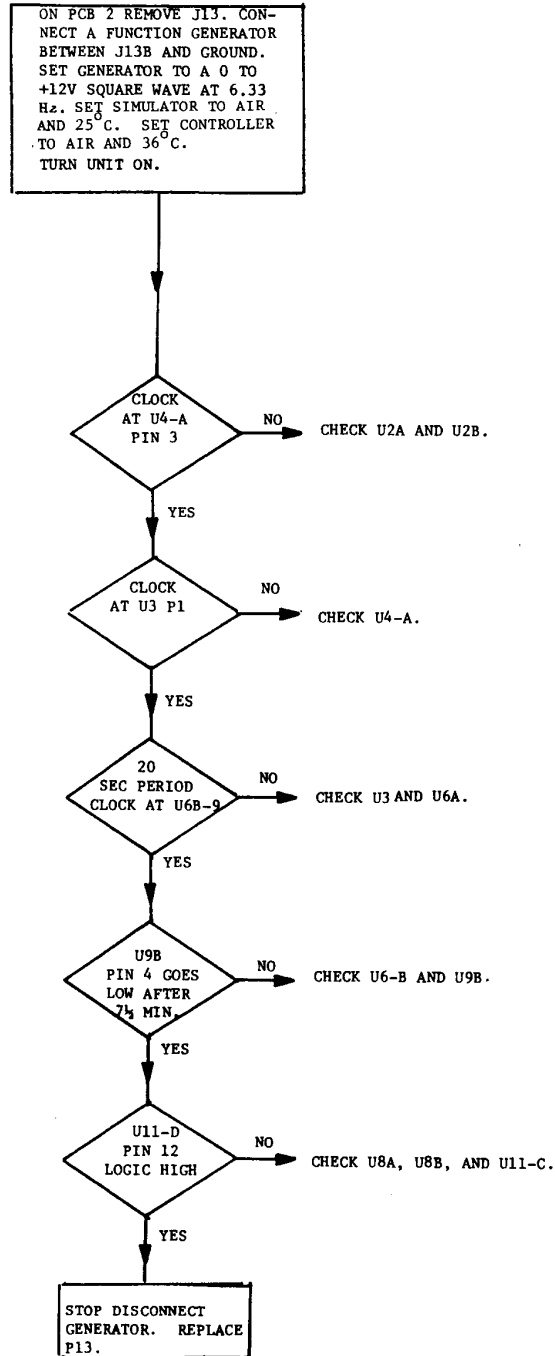

FLOWCHART 5.6 ONE HOUR TIMER TROUBLESHOOTING

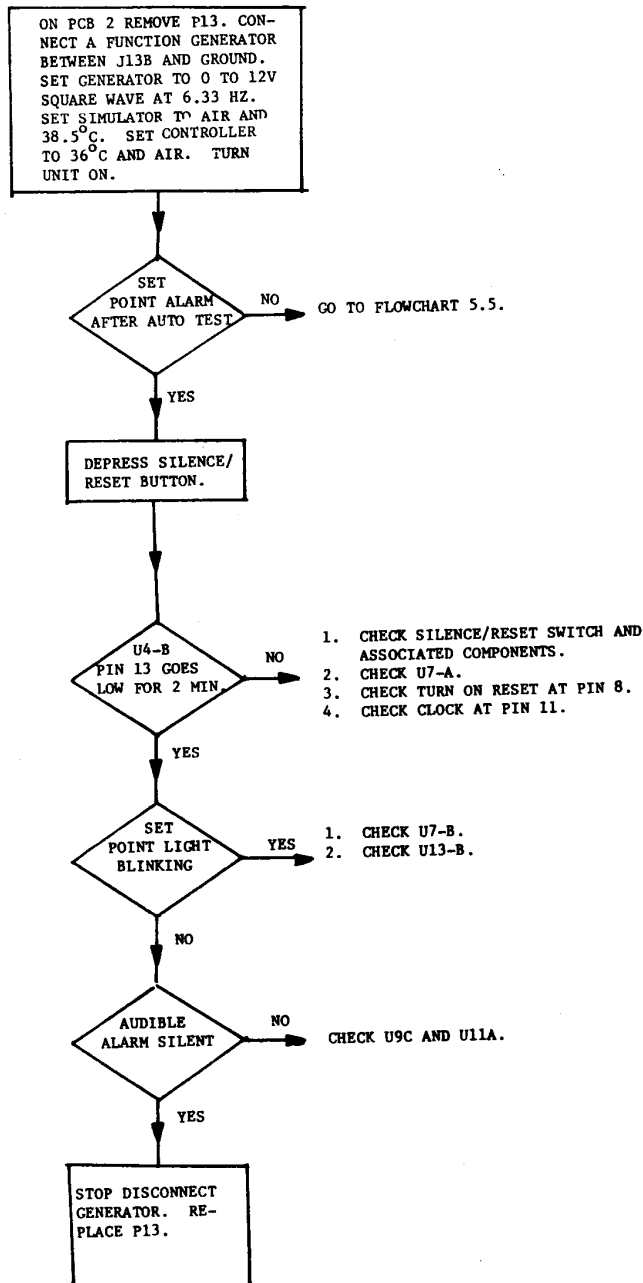

FLOWCHART 5.7 15 MINUTE TIMER TROUBLESHOOTING



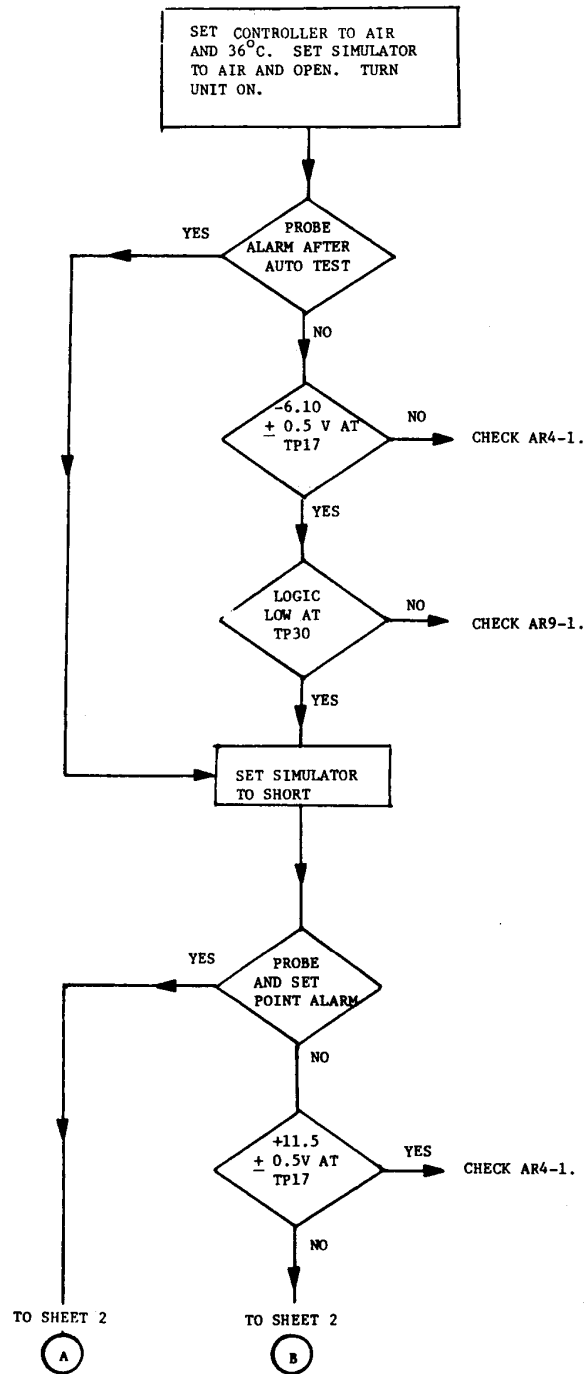

**FLOWCHART 5.8 AIR AND SKIN\* PROBE ALARMS TROUBLESHOOTING  
(SHEET 1 of 5)**

\* Model C100 Only.

C100/200  
SERVICE

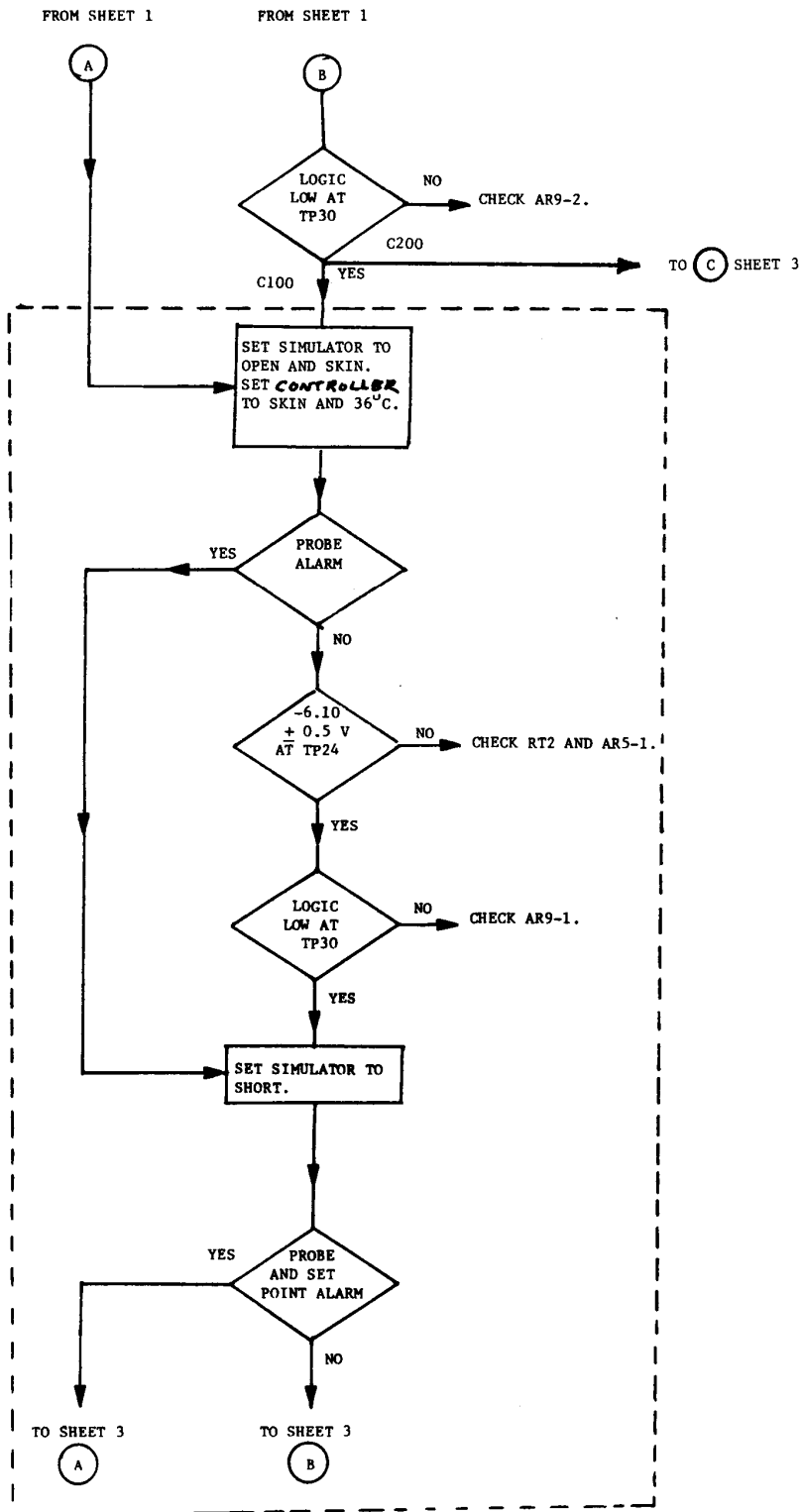

**FLOWCHART 5.8 AIR AND SKIN\* PROBE ALARMS TROUBLESHOOTING  
(SHEET 2 of 5)**

\*Model C100 Only.

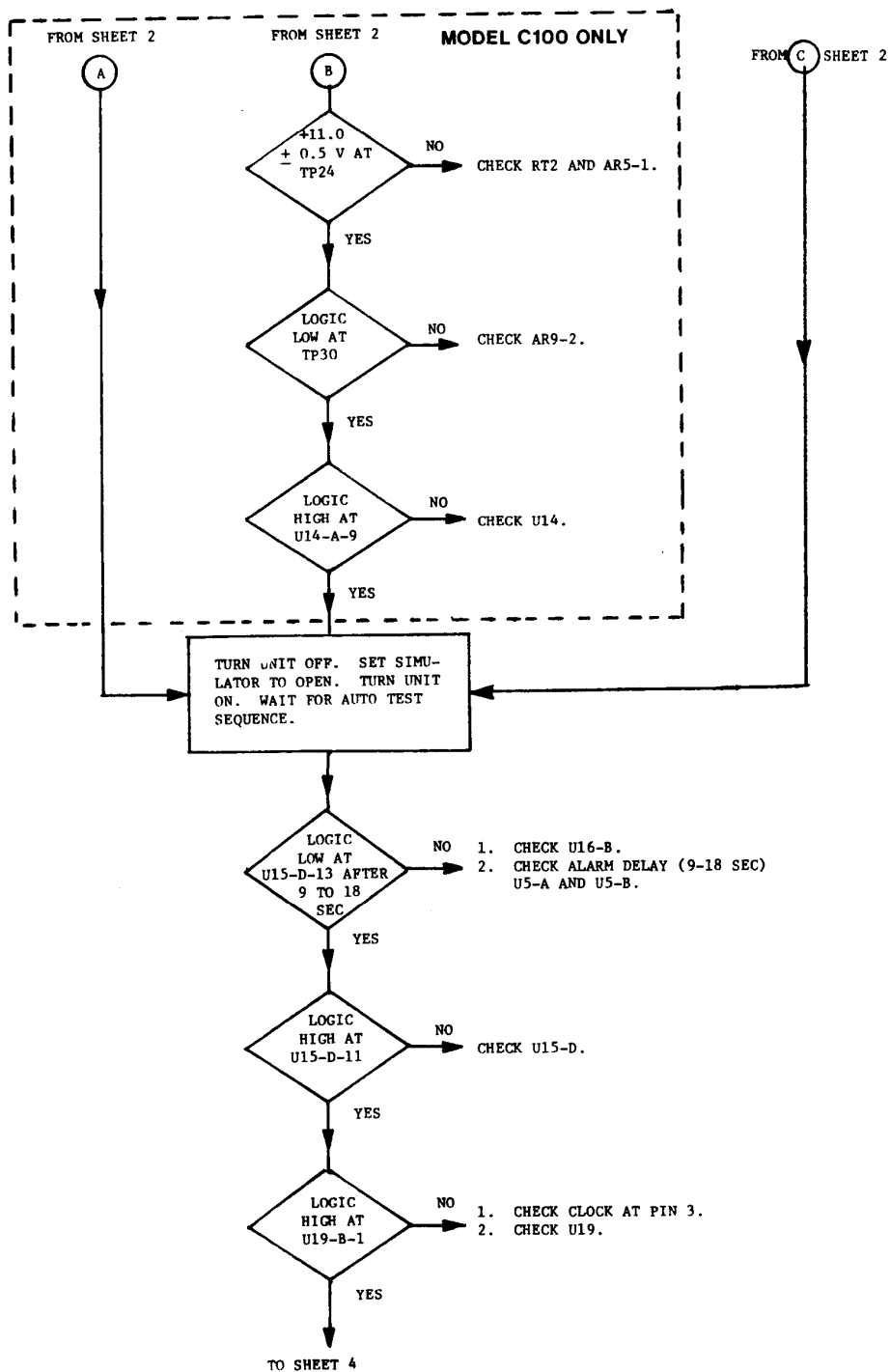

**FLOWCHART 5.8 AIR AND SKIN\* PROBE ALARMS TROUBLESHOOTING  
(SHEET 3 of 5)**

\* Model C100 Only.

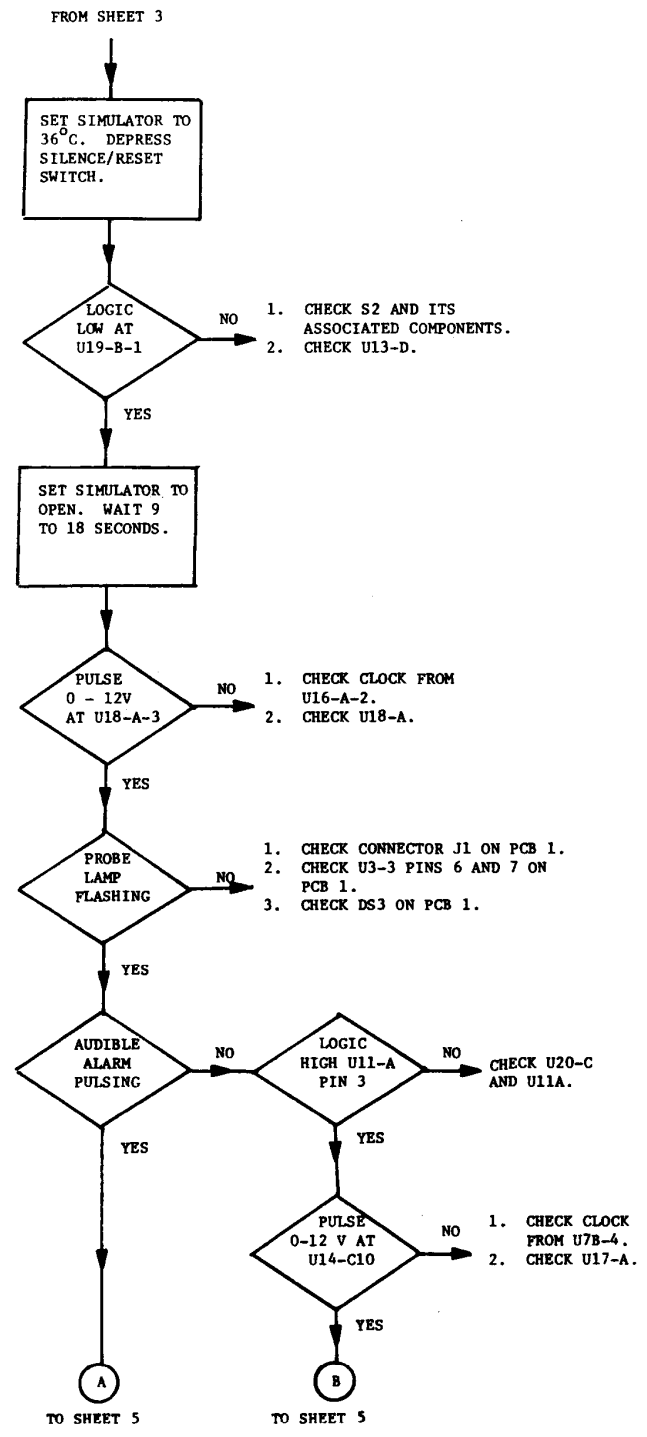

**FLOWCHART 5.8 AIR AND SKIN\* PROBE ALARMS TROUBLESHOOTING (SHEET 4 of 5)**

\* Model C100 Only.

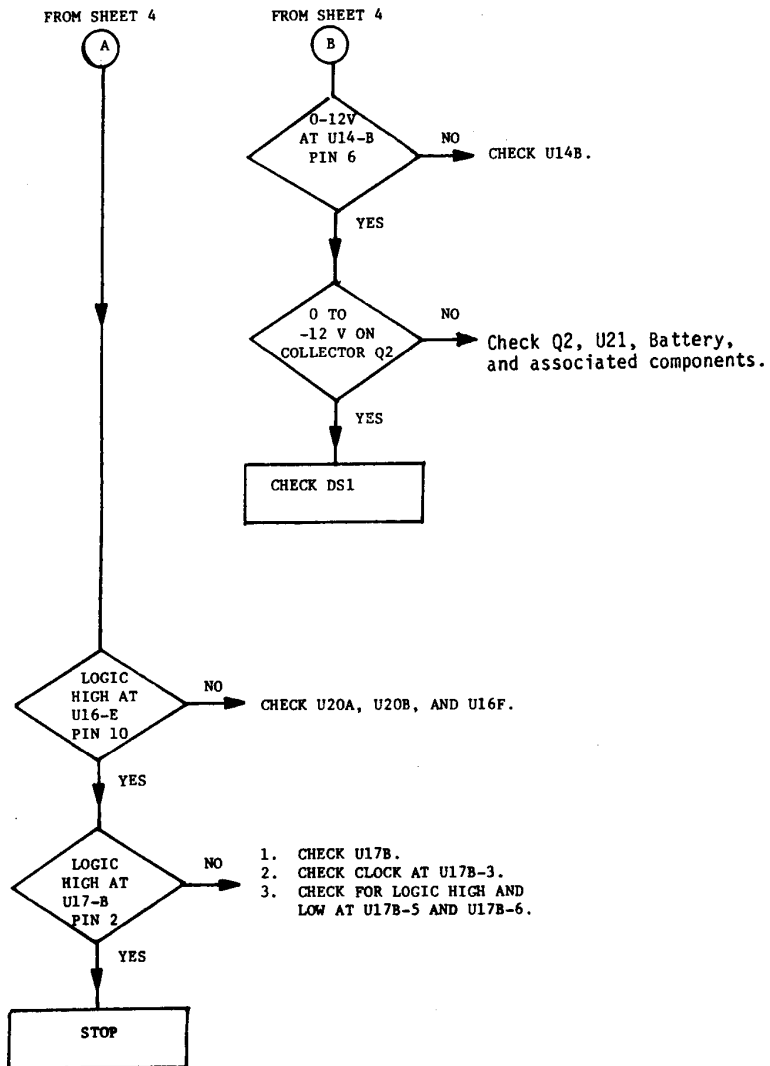

**FLOWCHART 5.8 AIR AND SKIN\* PROBE ALARMS TROUBLESHOOTING  
(SHEET 5 of 5)**

\* Model C100 Only.

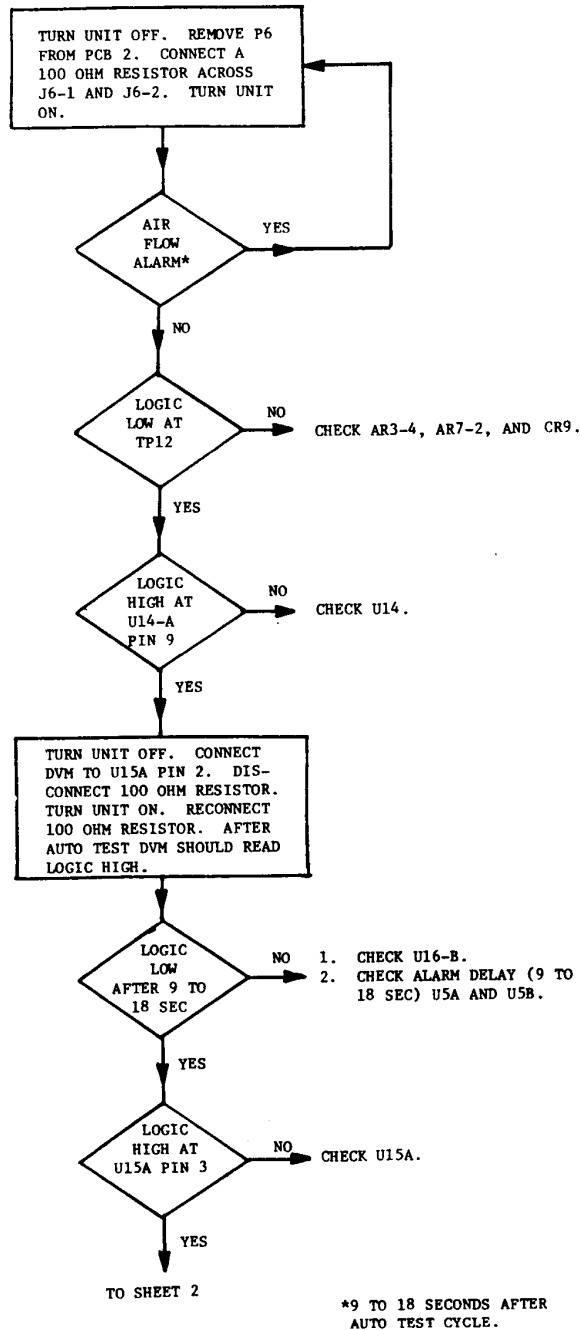

FLOWCHART 5.9 AIR FLOW ALARM TROUBLESHOOTING (SHEET 1 of 3)

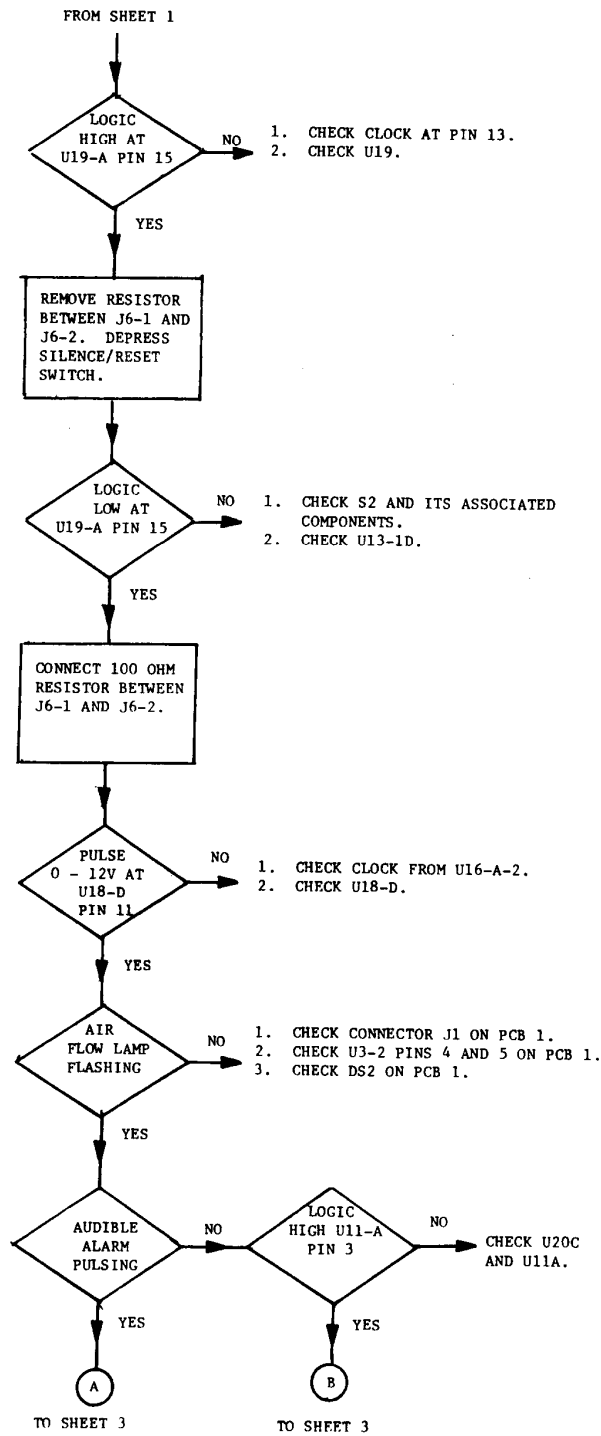

**FLOWCHART 5.9 AIR FLOW ALARM TROUBLESHOOTING (SHEET 2 of 3)**

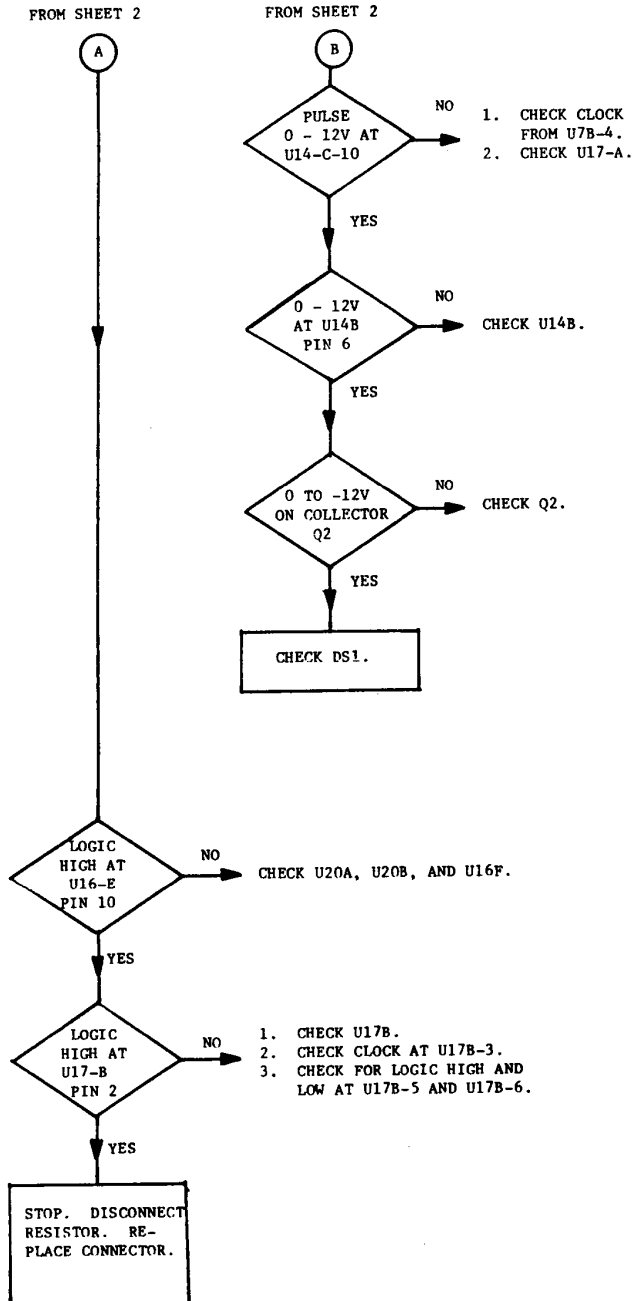

FLOWCHART 5.9 AIR FLOW ALARM TROUBLESHOOTING (SHEET 3 of 3)



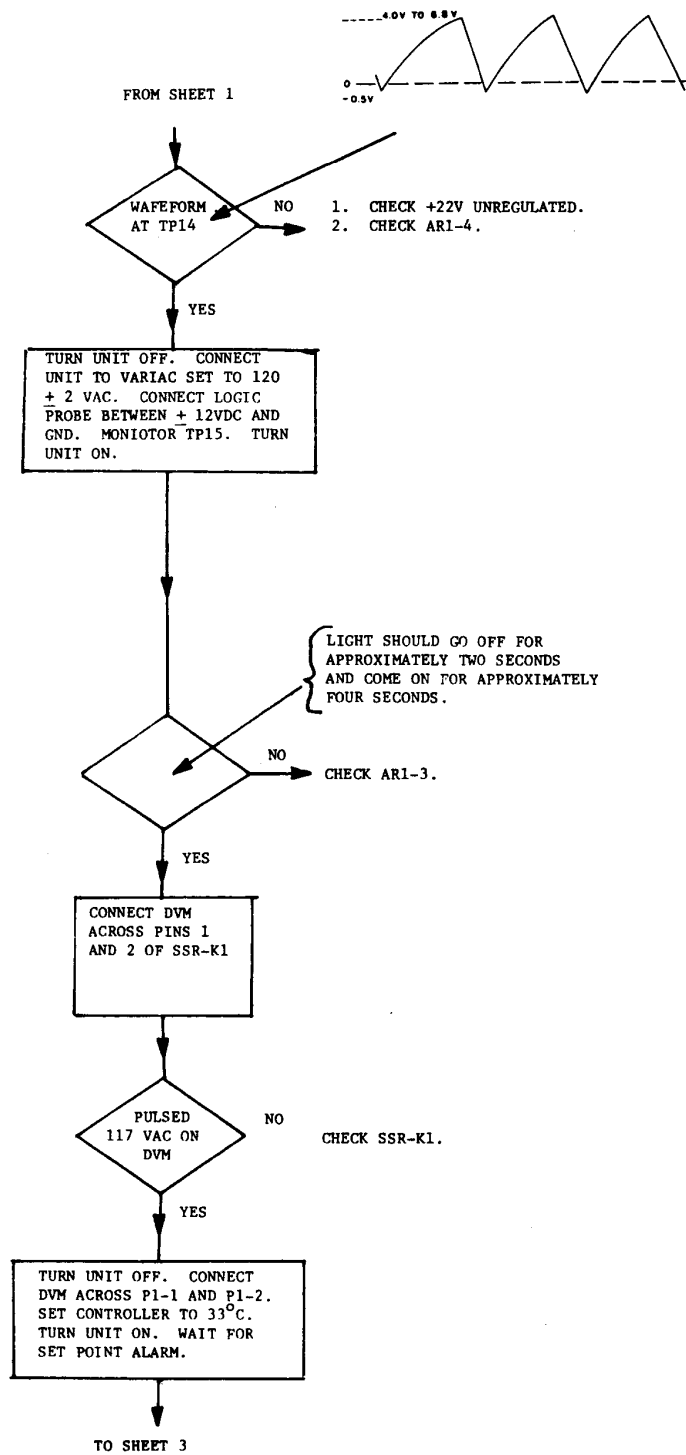

FLOWCHART 5.11 HEATER CIRCUITRY TROUBLESHOOTING (SHEET 2 of 4)

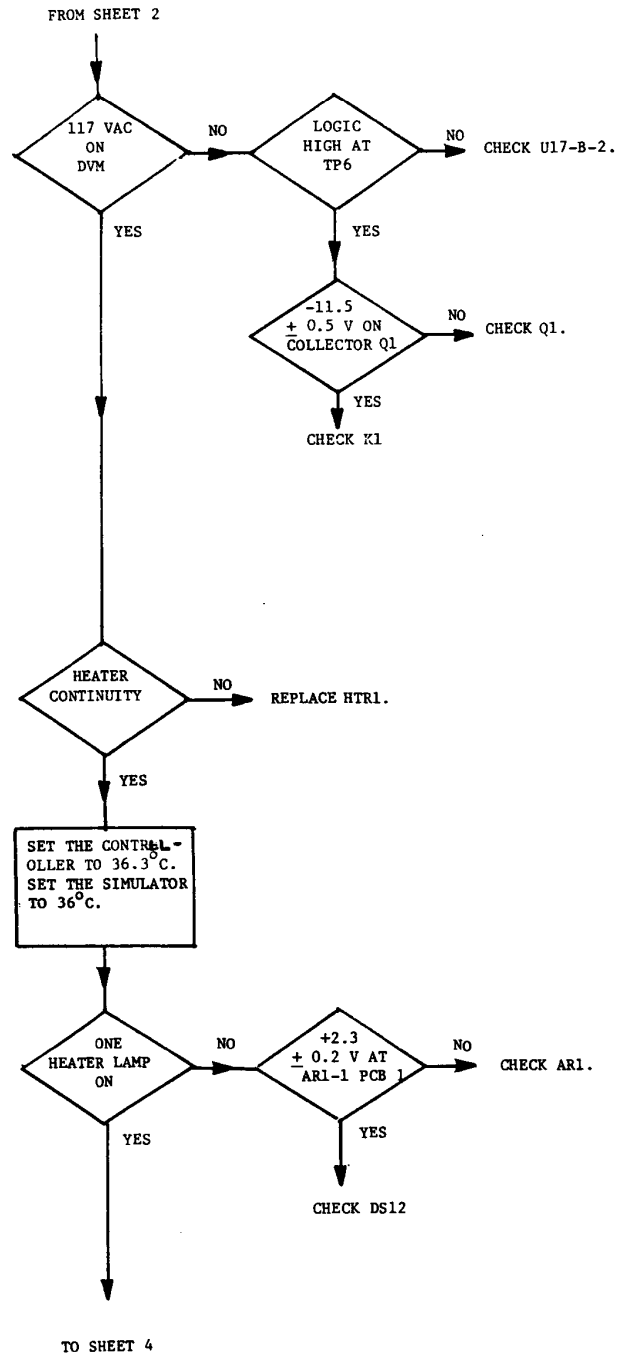

FLOWCHART 5.11 HEATER CIRCUITRY TROUBLESHOOTING (SHEET 3 of 4)

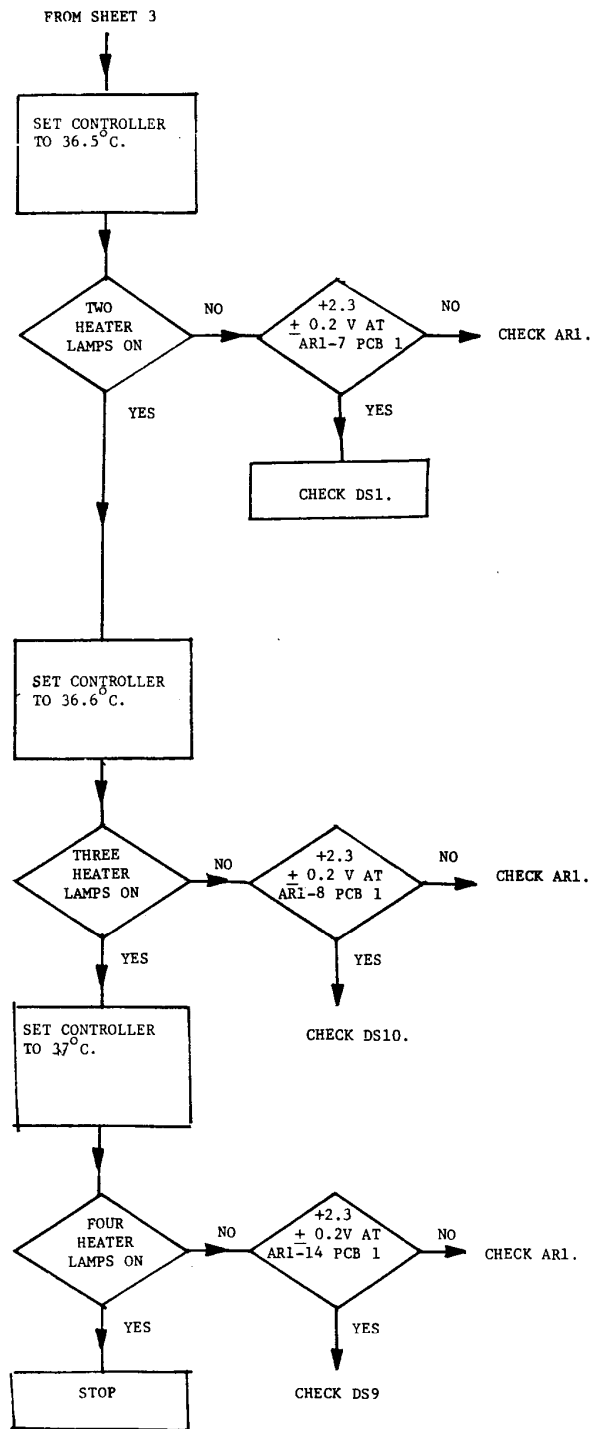

FLOWCHART 5.11 HEATER CIRCUITRY TROUBLESHOOTING (SHEET 4 of 4)

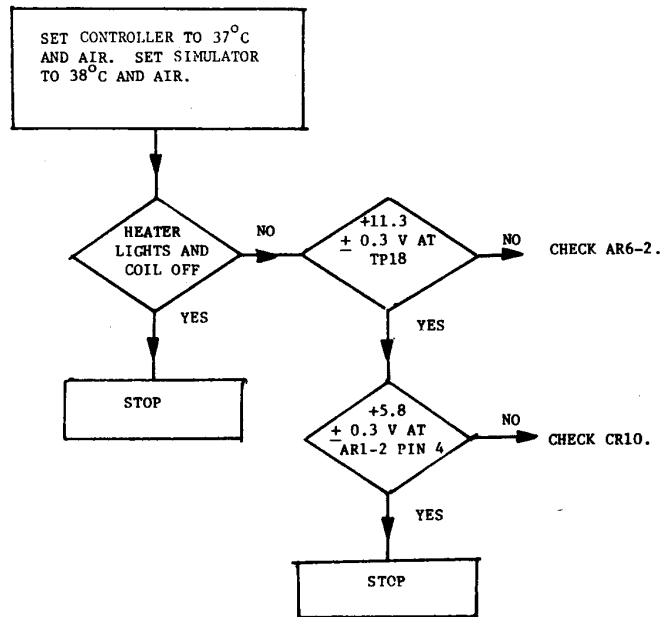

**FLOWCHART 5.12 38°C AIR TEMP. SHUTDOWN TROUBLESHOOTING**

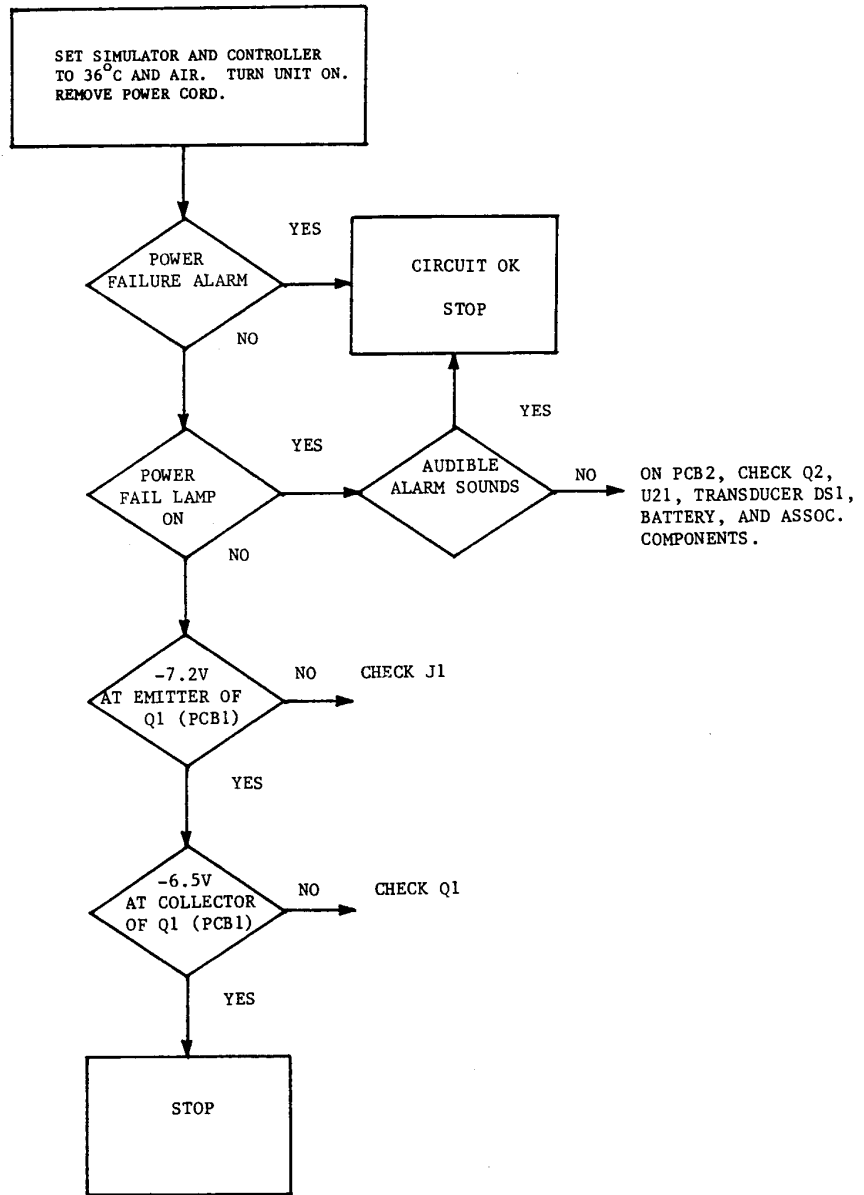

FLOWCHART 5.13 POWER FAILURE ALARM TROUBLESHOOTING

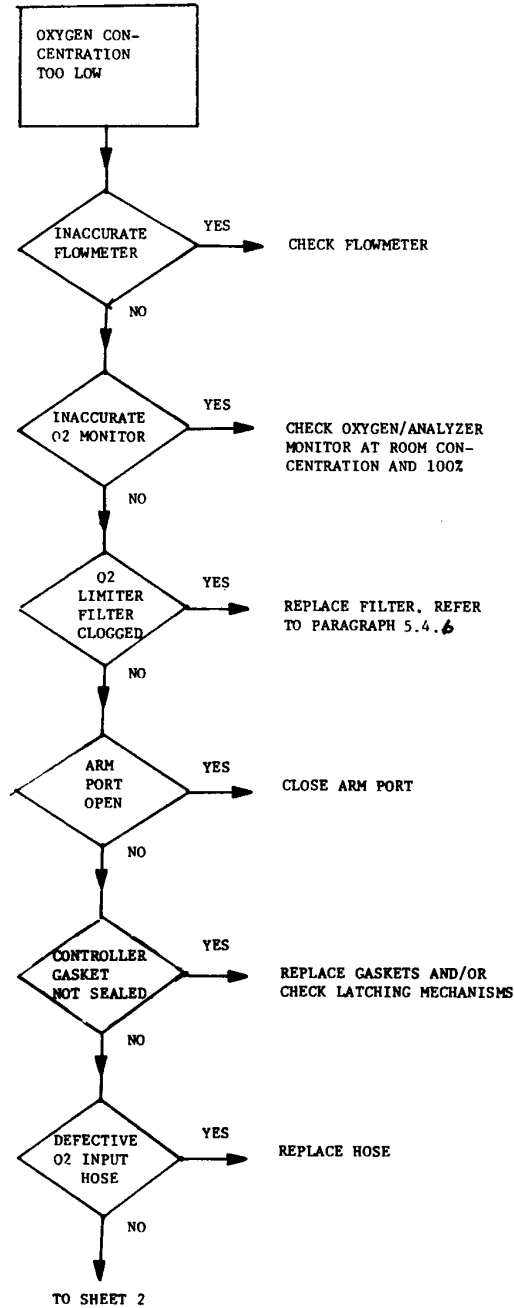

FLOWCHART 5.14 OXYGEN CONCENTRATIONS (SHEET 1 of 2)

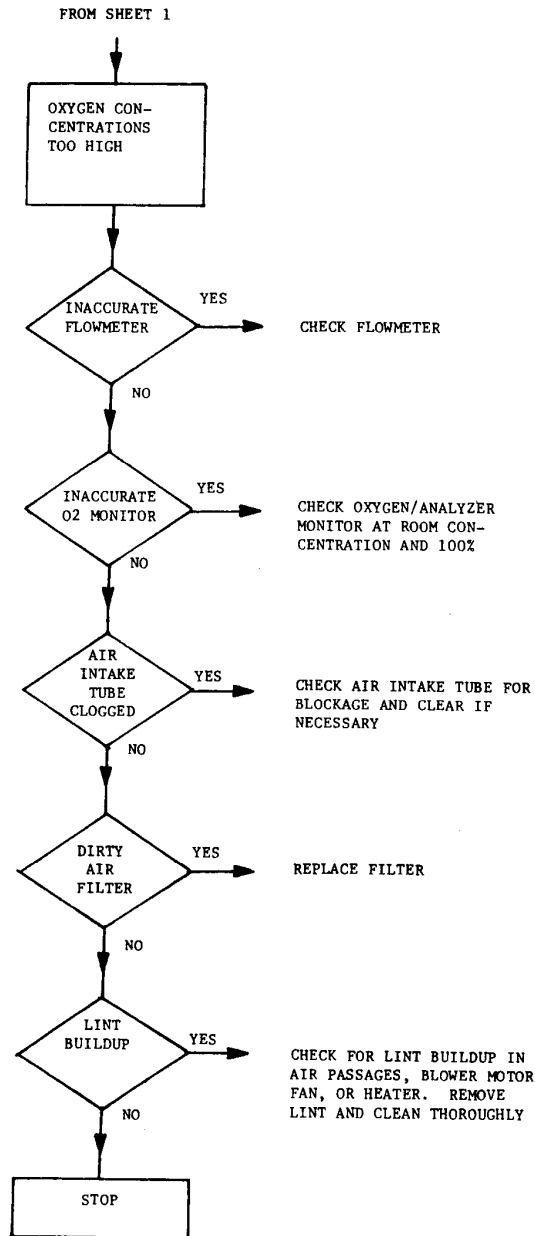

FLOWCHART 5.14 OXYGEN CONCENTRATIONS (SHEET 2 of 2)

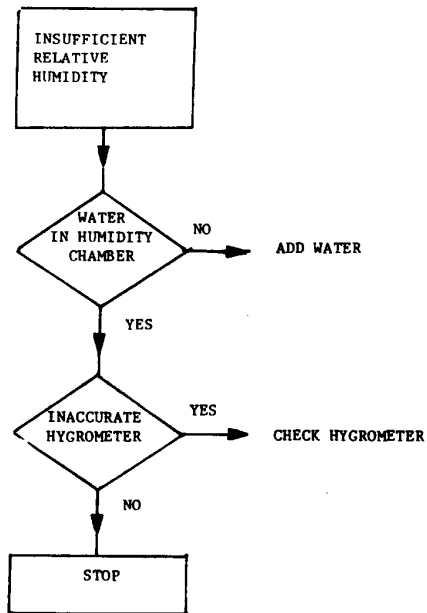

**FLOWCHART 5.15 INSUFFICIENT RELATIVE HUMIDITY**



## 5.4 REMOVAL AND REPLACEMENT PROCEDURES

### 5.4.1 GENERAL

This section provides removal and replacement procedures for components of the Incubator. Removal and replacement procedures for components other than those provided are obvious upon inspection.

### 5.4.2 CONTROLLER FRONT PANEL

1. Remove the Controller from the Incubator.
2. Remove the four phillips head screws located behind the handles.
3. If required, remove plugs P1 through P9, and P11. Disconnect in-line connector P15.
4. To replace the Controller Front Panel, reverse steps 1 through 3.

### 5.4.3 PCB2

1. Remove the Controller Front Panel as described above.
2. Remove the five phillips head screws that hold the printed circuit board to the panel.
3. Remove the CONTROL MODE knob\*.
4. Remove plugs P1 through P9, P11, and P12. Disconnect in-line connector P15.
5. Remove PCB 1 as described below.
6. To replace PCB 2, perform steps 1 through 5 in reverse order.

### 5.4.4 PCB1

1. Remove the Controller Front Panel and PCB2 as described above.
2. Remove ribbon cable from J1.
3. Use long nose pliers to remove the five snap-in board supports from PCB2.
4. To replace the board, push the snap-in board supports into PCB2 and reconnect the ribbon cable to J1.

\* Model C100 Only.

#### 5.4.5 POWER AND SILENCE/RESET SWITCHES

1. To remove the POWER switch, unscrew the bezel. Disconnect in-line connector P15. Remove the nut holding the switch to the Front Panel.
2. To remove the SILENCE/RESET switch, unscrew the bezel. Disconnect P11 from PCB2. Remove the nut holding the switch to the front panel.

#### 5.4.6 OXYGEN INPUT VALVE FILTER CARTRIDGE

1. Refer to Figure 5.5 and remove the three screws which hold the Input Valve to the Air-Intake Filter Cover.
2. Replace the Filter Cartridge (part no. 68 130 67) and reassemble the Oxygen Input Valve as shown in Figure 5.5.

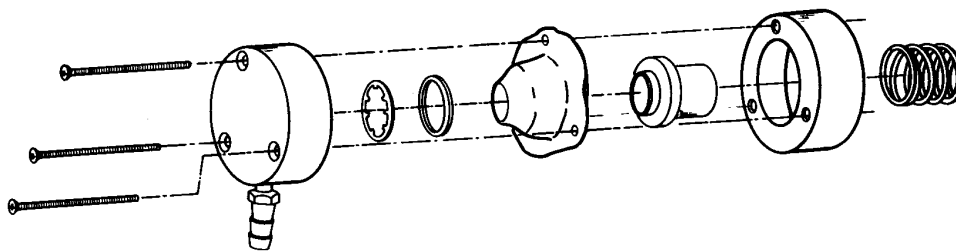

**FIGURE 5.5 OXYGEN INPUT VALVE ASSEMBLY**

## SECTION 6 PARTS LIST

### 6.1 GENERAL

This section provides parts lists for the Model C100 and C200 Incubators. Part Numbers of accessories and single use items are provided below.

#### ACCESSORIES

Accessory Shelf *	26 610 84
Sterilizer Tank	26 517 01
Vapojette Humidifier	26 750 70
Weighing Scale	26 830 70
Weighing Hook (15" for Weighing Scale)	26 610 76
(22" required when Weighing Scale is on Accessory Shelf)	26 610 78
Weighing Sling	26 830 20
I.V. Pole	68 452 70
Accessory Trays	
Right Side	26 850 70
Left Side	26 810 70
Oxygen Cylinder Rack	26 840 70

#### SINGLE USE ITEMS

Entry Port Sleeves (100 per case)	26 920 70
Access Door Cuffs Disposable (100 per case)	26 934 81
Mattresses (10 per case)	79 265 10
Sofspots™ Probe Covers (Case of 600)	26 901 80
Storage Covers (50 per pack)	26 920 72
Humidity Indicator Cards (5 per pack)	68 120 43
Kleenaseptic® Surface Cleaner (12 per pack)	79 251 72
Vaposeptic® Air Sanitizer (Carton of 12)	79 250 71

\* The counterweight supplied with the Accessory Shelf must be installed in the Cabinet Stand to meet the 10° tilt test. Refer to the Installation Instructions, Catalog No. 26 990 36-1 supplied with the Accessory Shelf.

C100/200  
PARTS LIST

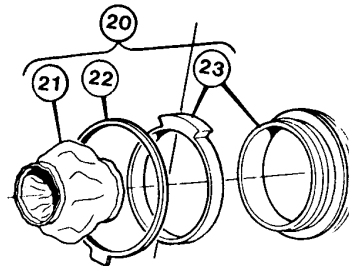
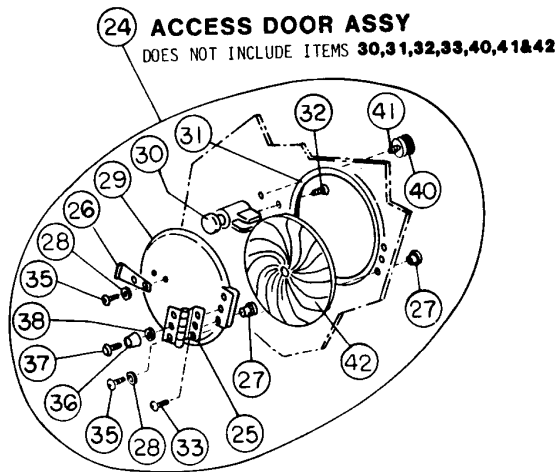
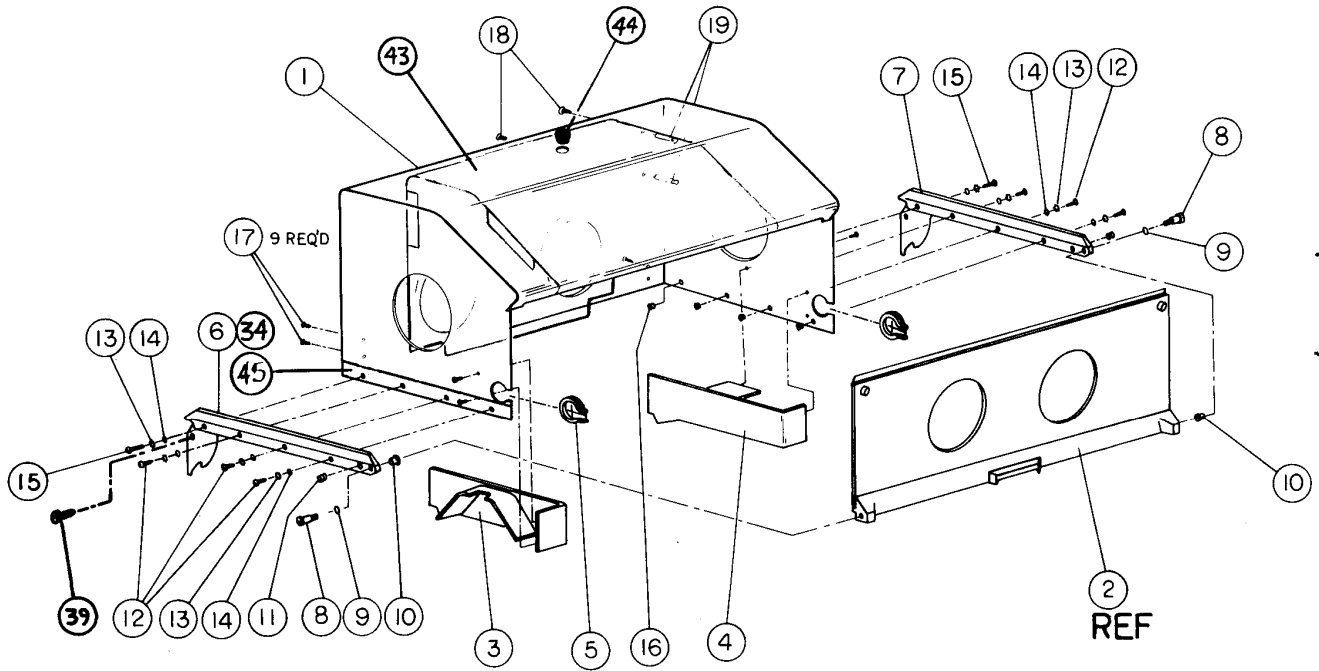

FIGURE 6.1 PARTS LOCATION DIAGRAM, HOOD ASSEMBLY

**TABLE 6.1 HOOD ASSEMBLY, PARTS LIST (SHEET 1 of 2)**

PART NO. 68 147 70, Model C100 (Includes Heat Shield)  
PART NO. 68 149 70, Model C200 (W/O Heat Shield)

ITEM NO.	DESCRIPTION	PART NO.
1	Replacement Hood Kit (Plexiglas only)	68 902 74
2	Access Panel Assy. (Refer to Figure 6.2)	
3	Baffle, Left (Plexiglas Assy.)	68 156 71
4	Baffle, Right (Plexiglas Assy.)	68 156 75
5	Grommet, Access	67 120 45
6	Strip, Hood Mounting, Side, Left	68 121 10
7	Strip, Hood Mounting Side, Right	68 121 00
8*	Screw, Shoulder, Slotted Head	68 121 30
9*	Washer, Non-Metallic, 3/8 I.D.	68 121 40
10*	Brq, Flanged, Non-Metallic 3/8 I.D.	68 121 35
11*	Plunger, Spring	68 121 45
12	Scr. 10-32 x 5/8 TR. PH, SS	99 042 58
13	Washer, Lock, Internal No. 10, SS	99 123 92
14	Washer, Flat, .219 I. D. x .366 O.D., SS	99 123 64
15	Screw, 10-32 x 7/8 TR PH SS	99 043 18
16	Stud, Threaded, 10-32	26 301 14
17	Screw, No. 6 x 1/2, BF, FL, PH, S4, PASS	99 085 55
18	Screw, 6-32 x 3/4 FL, PH, SS (100°)	99 024 61
19	Mounting Stud, Card	68 120 41
20	Iris Port Assy.	12 612 70
21	Sleeve, Iris Port, Reusable (P/O item 20)	12 615 00
22	Retainer Ring, Iris Port (P/O item 20)	12 616 01
23	Ring Assy., Iris Port (P/O item 20)	12 612 74
24	Access Door Assy.	26 652 73
25	Hinge, Access Door (P/O item 24)	26 651 12
26	Strike (P/O Item 24)	26 669 30
27	Nut, Blind 6-32 (P/O item 24)	26 651 10
28	Wash #6 LK, SHI, SS (P/O item 24)	99 122 19
29	Access Door (P/O Item 24)	26 650 00
30	Latch Assy.	26 669 70
31	Gasket, Access Door	68 120 00
32	Scr, 6-32 x 1/4 FL, PH, SS (100°)	99 022 77
33	Scr, 6-32 x 3/16 TR, PH, SS	99 022 44
34*	Trim Strip	68 400 26
35	Scr 6-32 x 5/16 TR, PH, SS (P/O Item 24)	99 022 98
36	Door Stop (P/O Item 24)	26 605 00
37	Scr 6-32 x 9/16 RD, PH, SS	99 024 15
38	Bumper Spacer (P/O Item 24)	26 651 15
39*	Screw, Shoulder, Slotted Head (Secures Hood to Base)	68 120 50

\* Not supplied with Hood Assembly- Must be ordered separately.

C100/200  
PARTS LIST

**TABLE 6.1 HOOD ASSEMBLY, PARTS LIST (SHEET 2 of 2)**

PART NO. 68 147 70, Model C100 (Includes Heat Shield)  
PART NO. 68 149 70, Model C200 (W/O Heat Shield)

ITEM NO.	DESCRIPTION	PART NO.
40	Knob, Retainer, Small	68 157 61
41	Setscrew, 6-32 x 9/16 SE SK SS NY CP	99 024 17
42*	Access Cuff (Case of 100)	26 934 81
43	Heat Shield Assembly (Optional on C200)	68 122 70
44	Stopper, Weighing Hook	12 621 70
45	Strip, Plastic, White (Part of item 1)	68 147 00

\* Not supplied with Hood Assembly - Must be ordered separately.

C100/200  
PARTS LIST

(This page is intentionally left blank.)

C100/200  
PARTS LIST

PAWL, LATCH ASSEMBLY

P/No 6890296

28:00

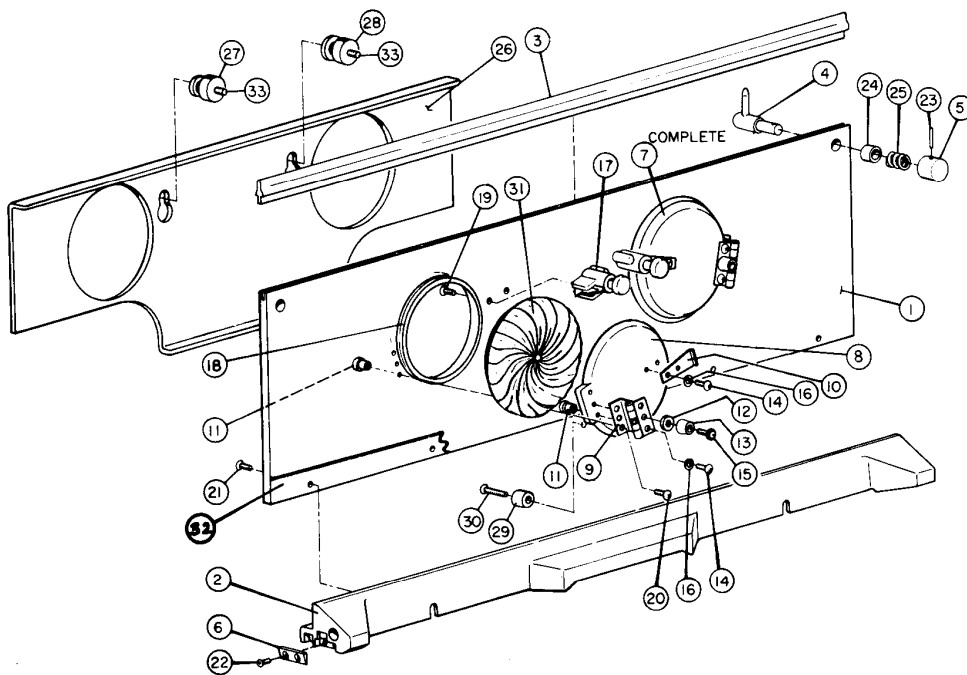

FIGURE 6.2 PARTS LOCATION DIAGRAM, ACCESS PANEL ASSEMBLY



C100/200  
PARTS LIST

**TABLE 6.2 ACCESS PANEL ASSEMBLY, PARTS LIST**

PART NO. 68 159 70, Model C100 (Includes Heat Shield)  
PART NO. 68 158 70, Model C200 (W/O Heat Shield)

ITEM NO.	DESCRIPTION	PART NO.
1	Panel, Access (Plex only; includes items 3 and 32)	68 157 75
2	Strip, Access Panel Mounting, Front (Blue)	68 121 20
3	Strip, Sealing	68 157 21
4	Pawl, Latch	68 157 40
5	Knob	68 157 11
6	Plate, Striker	68 121 55
7	Access Door Assy. Complete (includes items 8 through 16)	26 652 73
8	Access Door	26 650 00
9	Hinge, Access Door	26 651 12
10	Strike	26 669 30
11	Blind Nut 6-32	26 651 10
12	Spacer Bumper	26 651 15
13	Stop Door	26 605 00
14	Screw, #6-32 x 5/16 TR, PH, SS	99 022 98
15	Screw, #6-32 x 9/16 RD, PH, SS	99 024 15
16	Washer, #6 LK, SHI, SS	99 122 19
17	Latch Assy.	26 669 70
18	Gasket, Access Door	68 120 00
19	Screw, 6-32 x 1/4 FL, PH, SS (100°)	99 022 77
20	Screw, 6-32 x 3/16 TR, PH, SS	99 022 44
21	Screw, 8-32 x 5/16 TR, PH, SS	99 031 05
22	Screw 6-32 x 1/4 FL, PH, SS	99 022 75
23	Pin, Spring, 15/16 LG, SS	99 142 73
24	Spacer, Non-Metallic	68 157 45
25	Spring, Compression	68 157 50
26	Shield, Heat (Optional on Model C200)	68 157 55
27	Knob, Retainer, Small	68 157 61
28	Knob, Retainer, Large	68 157 60
29	Stop	68 157 66
30	Screw, 8-32 x 7/8 FL, PH, SS	99 033 19
31	Access Door Cuff, Disposable (Case of 100)	26 934 81
32	Strip, Plastic, White (Part of item 1)	68 158 00
33	Screw, Set, 6-32 x 9/16 SE, SK, SS, NY, CP	99 024 17

C100/200  
PARTS LIST

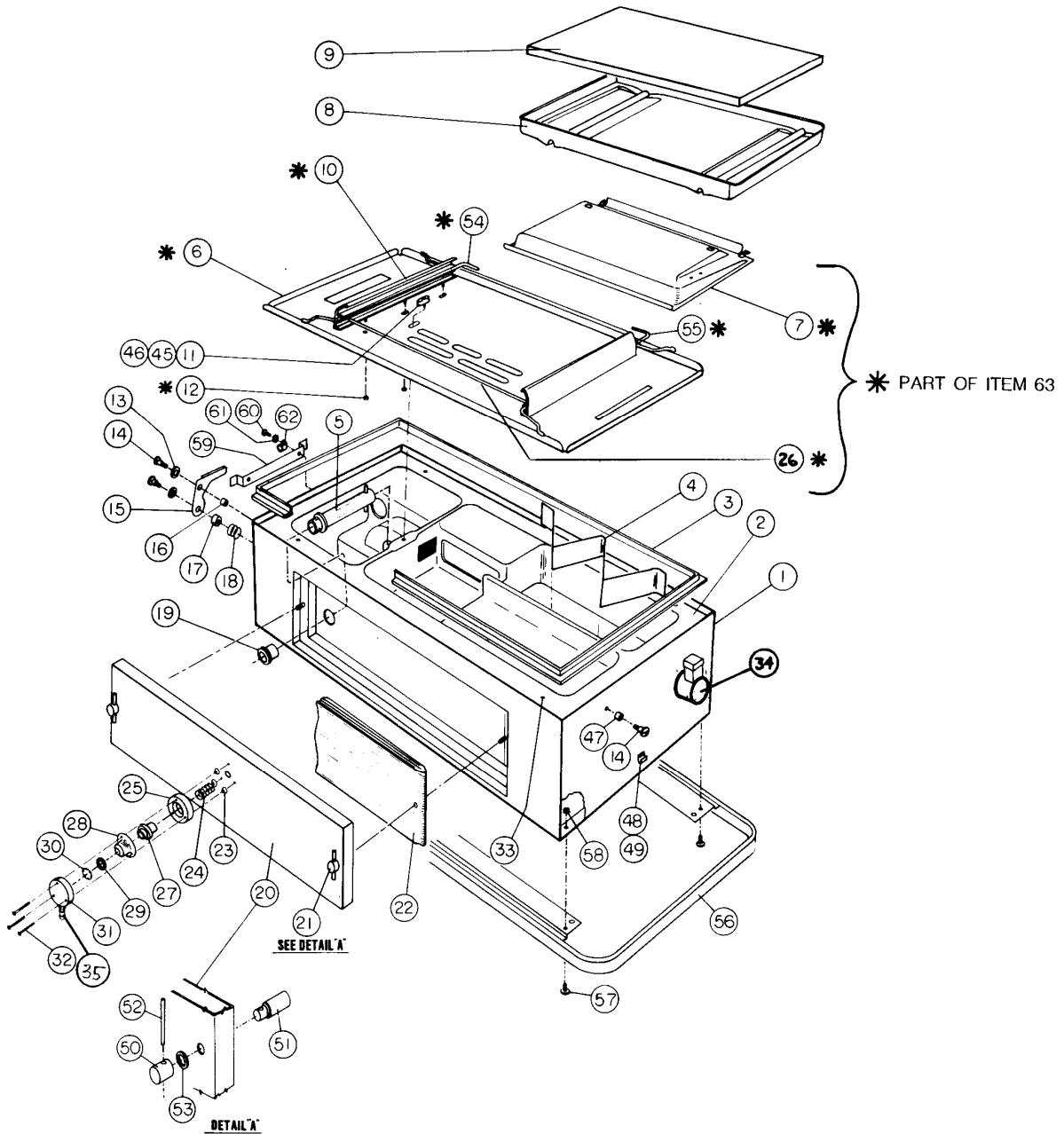

FIGURE 6.3 PARTS LOCATION DIAGRAM, SHELL ASSEMBLY AND DECK ASSEMBLY

**TABLE 6.3 SHELL ASSY. AND DECK ASSY., PARTS LIST (SHEET 1 of 2)**

ITEM NO.	DESCRIPTION	PART NO.
	Shell Assy., W/O Ice Chamber: English Labeling (120V) English Labeling (240V) Spanish Labeling French Labeling German Labeling	68 110 70 68 110 71 68 110 80 68 110 90 68 110 96
	Shell Assy., With Ice Chamber: English Labeling (120V) English Labeling (240V) Spanish Labeling French Labeling German Labeling	68 111 70 68 111 71 68 111 80 68 111 90 68 111 96
1	Shell, W/O Ice Chamber	68 110 00
	Shell, With Ice Chamber	68 110 01
2	Main Box Machining	26 100 30
3	Gasket, Hood	12 216 00
4	Baffle, Humidity Reservoir	26 101 02
5	Cross Feed Pipe Assy.	68 112 80
6 *	Main Deck, Replacement <i>#389 - 10%</i>	68 902 71
7 *	Air Curtain Cover	68 141 70
8	Deck, Mattress	68 160 00
9	Mattress/Cover Assy.	68 142 70
10*	Rail, Deck	68 141 18
11	Knob, Bar, Plastic	68 140 01
12*	Nut, 8-32, .250 HX x .070 THK, BR, NI, PL <i>.060</i>	99 106 68
13	Washer, 3/8 x 5/8 FL, SS .064 THK	99 126 70
14	Screw, Shoulder, Slotted	68 110 51
15	Handle, Latch	68 110 55
16	Spacer, Non-Metalic	68 110 58
17	Spacer, Non-Metalic	68 110 56
18	Spring, Torsion	68 110 57
19	Grommet, Filter	68 112 15
20	Filter Cover Assy.: English Labeling Spanish Labeling French Labeling German Labeling	68 133 70 68 133 75 68 133 80 68 133 85
21	Cover, Filter	68 130 00
22	Filter Pad (Box of 4)	26 945 70
23	Spacer, Non-Metalic	68 130 52
24	Spring, Compression	68 130 65
25	Cylinder	68 130 55
26*	Shaft, Plenum	68 141 32

\* Part of item 63.

C100/200  
PARTS LIST

**TABLE 6.3 SHELL ASSY. AND DECK ASSY., PARTS LIST (SHEET 2 of 2)**

ITEM NO.	DESCRIPTION	PART NO.
27	Filter, Cartridge Assembly	68 130 67
28	Diaphragm	68 130 57
29	Washer, Non-Metallic	68 130 51
30	Ring, Retaining, Wal 5105-62SS	99 182 93
31	Cap	68 130 60
32	Screw, 6-32 x 1-3/4 OV, PH, SS	99 026 18
33	Screw, 8-32 x 1/2 FL, SL, SS	99 031 96
34	Fill Spout Assy.	See Note
35	Fitting, Nipple, Hose	01 017 00
36	Not Used	
37	Not Used	
38	Not Used	
39	Not Used	
40	Not Used	
41	Not Used	
42	Not Used	
43	Not Used	
44	Not Used	
45	Shaft, Deck Retention	68 140 02
46	Screw, 8-32 x 1/4 PN, SL, SS	99 030 66
47	Spacer, Non-Metallic	68 110 59
48	Hook, Latch	24 144 00
49	Screw, 4-40 x 5/16 FL, S1, SS	99 010 76
50	Knob, Filter Cover	68 130 30
51	Shaft, Filter Cover Knob	68 130 35
52	Handle, Knob	68 130 40
53	Washer, .38 ID x .62 OD x .015 THK, FL, NY	99 126 11
54*	Elevator, R.H.	68 140 33
55*	Elevator, L.H.	68 140 32
56	Guard Rail	68 410 70
57	Screw, 10-32 x 1/2 TR, PH, SS	99 042 01
58	Nut, 10-32, HX, KEPS, CA	99 107 36
59	Cleat, Power Cord	68 110 53
60	Screw, 10-32 x 5/8 TR, PH, SS	99 042 58
61	Washer, No. 10, Lock, Split, ST	99 123 90
62	Cable Clamp, Loop Type	17 061 25
63	Main Deck Assembly	68 140 70

\* Part of Item 63.

NOTE: Replace with Replacement Kit, Part No. 68 902 70.

C100/200  
PARTS LIST

(This page is intentionally left blank.)

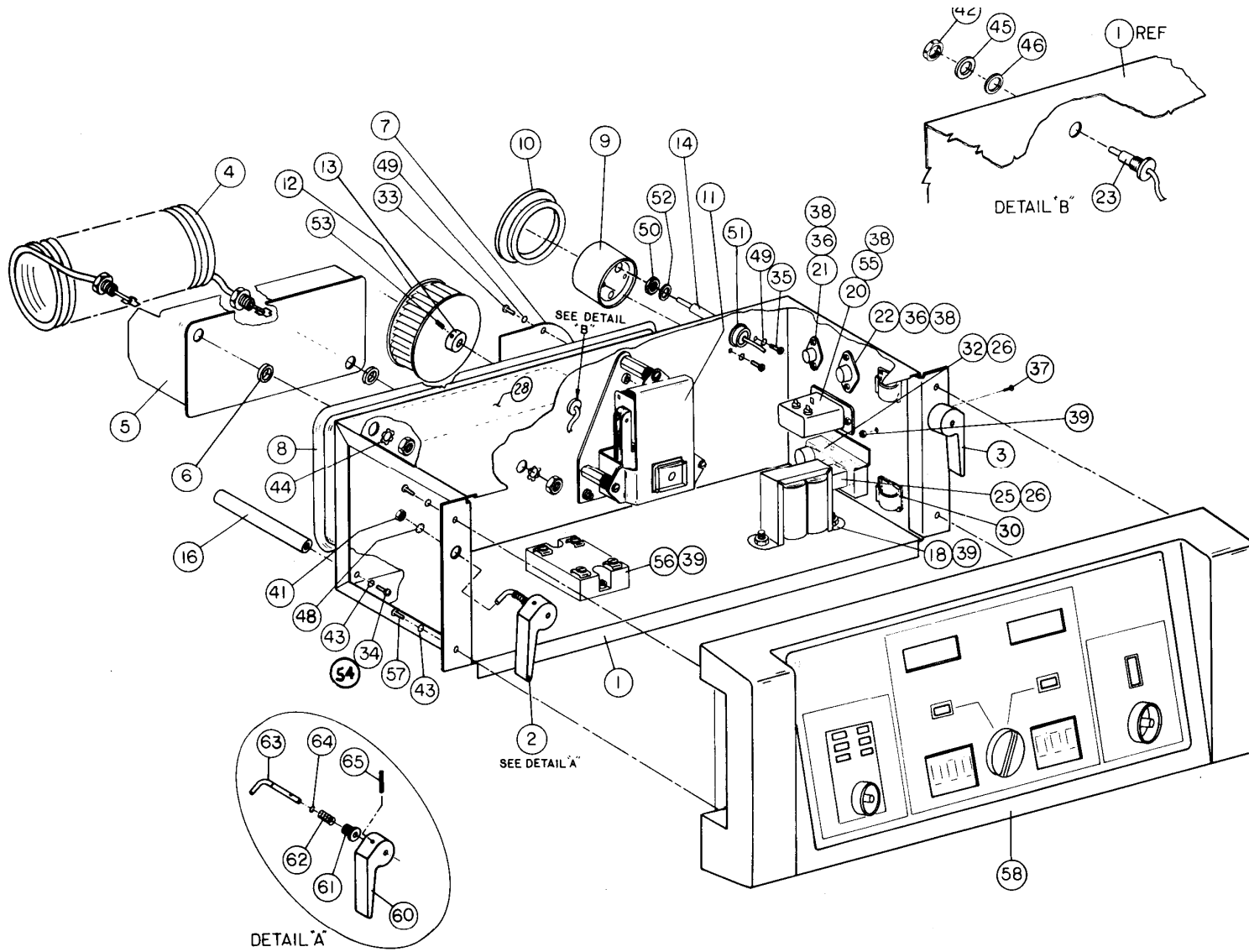

FIGURE 6.4 PARTS LOCATION DIAGRAM, MODEL C68 CONTROLLER

**TABLE 6.4 MODEL C68 CONTROLLER, PARTS LIST (SHEET 1 of 3)**

PART NO. 68 215 70, 120V, ENGLISH  
 PART NO. 68 215 80, 240V, ENGLISH  
 PART NO. 68 215 90, 100V, JAPANESE  
 PART NO. 68 215 83, 240V, GERMAN

PART NO. 68 215 71, 120V, SPANISH  
 PART NO. 68 215 72, 120V, FRENCH  
 PART NO. 68 215 81, 240V, SPANISH  
 PART NO. 68 215 82, 240V, FRENCH

ITEM NO.	REFERENCE DESIGNATION	DESCRIPTION	PART NO.
1		Chassis Assy., 120V Units	68 212 70
2		Chassis Assy., 240V Units	68 212 80
3		Chassis Assy., 100V Units	68 212 90
4	HTR1	Chassis, Controller (Weldment)	68 215 10
5	HTR1	Latch Assy., Left	68 207 80
6	HTR1	Latch Assy., Right	68 207 81
7	HTR1	Heater, 120V	68 208 25
8		Heater, 240V	68 208 26
9		Heater, 100V	68 208 27
10		Baffle/Plate, Heater	68 208 20
11		Spacer, Heater Plate	26 516 05
12		Plate, Stiffener	68 204 21
13*		Gasket	26 503 00
14		Plug, Thermostat	12 512 01
15		Gasket	26 501 00
16	B1	Motor Replacement Kit, 120V	68 903 80
17	B1	Motor Replacement Kit, 220V	68 903 81
18	B1	Motor Replacement Kit, 100V	68 903 82
19		Impeller	68 204 31
20		Adapter, Impeller	68 204 33
21	RT1A & B	Dual Thermistor Assy., Hi-Temp Alarm	68 214 70
22		Not Used	
23		Post, Bumper	68 215 12
24		Not Used	
25	T1	Power Transformer Assy., 120V	68 206 71
26	T1	Power Transformer Assy., 240V	68 206 77
27	T1	Power Transformer Assy., 100V	68 206 81
28		Not Used	
29	J14	Connector Assy., Power	68 205 81
30	J7	Receptacle Assy., Air Temperature Probe	68 209 85
31	J8	Patient Probe Rcpt. Assy.	68 209 75
32	RT4	Thermistor Assy., Air Flow	68 214 80
33		Not Used	
34	CB1	Circuit Breaker, Sgl. Pole, 5 Amp (100 and 120 Vac Units)	17 BH 150
35	CB1, CB2	Circuit Breaker, Sgl. Pole, 5 Amp ( 240 Vac Units)	17 BH 150

\*Used only on Jakel Motors

C100/200  
PARTS LIST

**TABLE 6.4 MODEL C68 CONTROLLER, PARTS LIST (SHEET 2 of 3)**

PART NO. 68 215 70, 120V, ENGLISH  
PART NO. 68 215 80, 240V, ENGLISH  
PART NO. 68 215 90, 100V, JAPANESE  
PART NO. 68 215 83, 240V, GERMAN

PART NO. 68 215 71, 120V, SPANISH  
PART NO. 68 215 72, 120V, FRENCH  
PART NO. 68 215 81, 240V, SPANISH  
PART NO. 68 215 82, 240V, FRENCH

ITEM NO.	REFERENCE DESIGNATION	DESCRIPTION	PART NO.
27		Not Used	
28		Label, Heater Caution	68 208 30
29		Not Used	
30		Clip, Cord	17 725 44
31		Not Used	
32		Button, Plug	22 035 40
33		Scr, 8-32 x 5/8 TR, PH, SS	99 032 57
34		Scr, 10-32 x 1/2 TR, PH, SS	99 042 01
35		Scr, 8-32 x 3/4 TR, PH, SS	99 032 85
36		Scr, 4-40 x 3/8 TR, PH, SS	99 011 07
37		Scr, 6-32 x 3/4 TR, PH, SS	99 024 69
38		Nut, 4-40 HX, "KEPS", S, CA	99 103 33
39		Nut, 6-32 HX, "KEPS", S, CAD, PL	99 105 34
40		Not Used	
41		Nut, 3/8-24, HX, JAM, SS	99 111 68
42		Nut, 3/8-24, HX, BR, NI, THIN	99 111 80
43		Wshr, LK, SP, #10, SCA	99 124 16
44		Wshr, 7/16 LK, SHI, S, CA	99 127 41
45		Wshr, 3/8 FL SS .064 THK	99 126 70
46		Wshr, Fibre	17 803 40
47		Label, Voltage 120V (not shown)	68 204 40
		Label, Voltage 240V (not shown)	68 204 41
		Label, Voltage 100V (not shown)	68 204 42
48		Wshr, 3/8 LK, SHI, S, CA	99 126 93
49		Wshr, No. 8, LK, SHI, S4	99 122 92
50		Nut, Hex, Thin, Electrical	99 115 20
51		Wshr, Fibre	99 127 69
52		Wshr, 1/2 ID x 11/16 OD x .015 NYL	99 127 96
53**		Scr, 6-32 SE, SK, SS, CP x 1/8 LG	99 022 17
54		Wshr, LK, EXT, #10, SS	99 123 94
55		Scr, 4-40 x 3/8 TR, PH, SS	99 011 07
56	K1	Relay, Solid State (100 and 120 Vac)	17 652 70
	K1	Relay, Solid State (240 Vac)	17 652 78
57		Scr, 10-32 x 3/8 TR, PH, SS	99 041 27
58		Front Panel Assy., Cont. (Refer to Table 6.6 for Parts Breakdown)	
59		Not Used	

\*\*Used only with item 13.



**TABLE 6.4 MODEL C68 CONTROLLER, PARTS LIST (SHEET 3 of 3)**

PART NO. 68 215 70, 120V, ENGLISH	PART NO. 68 215 71, 120V, SPANISH
PART NO. 68 215 80, 240V, ENGLISH	PART NO. 68 215 72, 120V, FRENCH
PART NO. 68 215 90, 100V, JAPANESE	PART NO. 68 215 81, 240V, SPANISH
PART NO. 68 215 83, 240V, GERMAN	PART NO. 68 215 82, 240V, FRENCH

ITEM NO.	REFERENCE DESIGNATION	DESCRIPTION	PART NO.
60		Handle, Latch	68 215 15
61		Bushing	68 215 25
62		Spring, Compression	20 016 03
63		Pawl, Latch	68 215 20
64		Ring, Retaining, Wal 5103-25	99 181 45
65		Pin, Spring, 3/32 Dia. x 1.00 LG	99 142 78
66		AC Line Cord, 120V (Not Shown)	17 AZ 100
		AC Line Cord, 220V (Not Shown)	17 AZ 200
67		Air Temperature (Not Shown)	68 209 80
68*		Skin Temperature (Not Shown)	68 209 70
69*		Cover, Probe, Skin Temp. (Box of 100) (Not Shown)	26 901 81

\* Model C100 only.

C100/200  
PARTS LIST

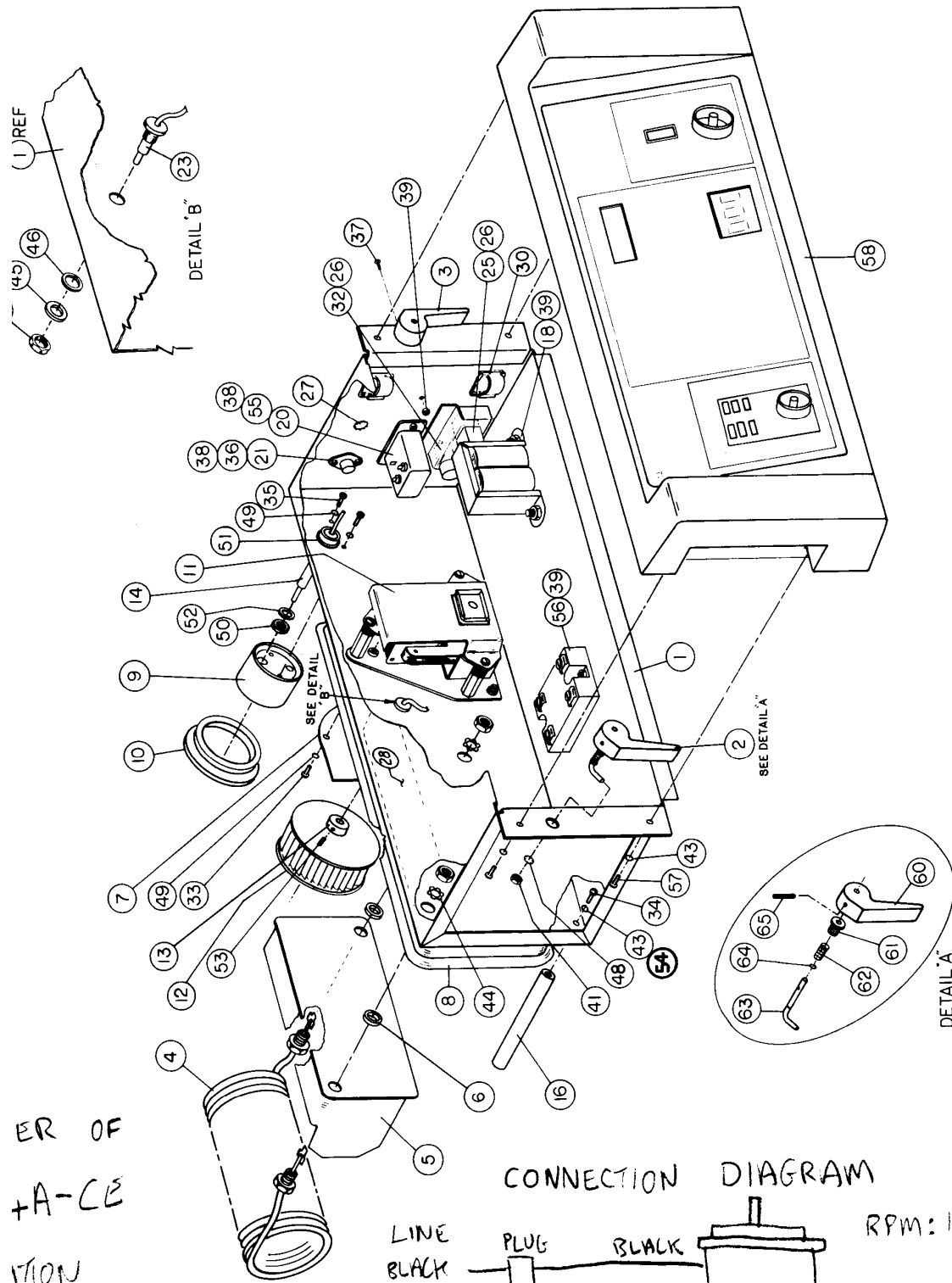

FIGURE 6.5 PARTS LOCATION DIAGRAM, MODEL C82 CONTROLLER

ER OF  
+A-CE

VISION  
IRONICS  
LIA P/L

52 6-16 (Change 1)

CONNECTION DIAGRAM

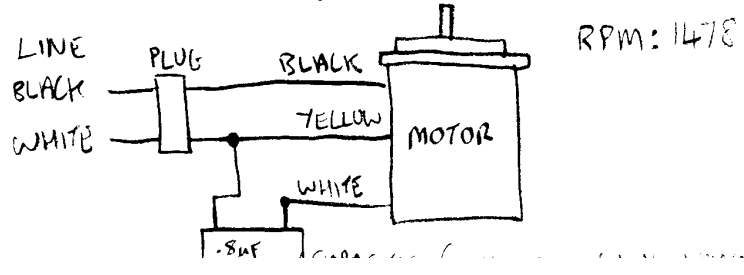

TABLE 6.5 MODEL C82 CONTROLLER, PARTS LIST (SHEET 1 of 3)

PART NO. 68 217 70, 120V, ENGLISH  
PART NO. 68 217 80, 240V, ENGLISH  
PART NO. 68 217 90, 100V, JAPANESE  
PART NO. 68 217 83, 240V, GERMAN

PART NO. 68 217 71, 120V, SPANISH  
PART NO. 68 217 81, 240V, SPANISH  
PART NO. 68 217 72, 120V, FRENCH  
PART NO. 68 217 82, 240V, FRENCH

ITEM NO.	REFERENCE DESIGNATION	DESCRIPTION	PART NO.
1	HTR1 HTR1 HTR1	Chassis Assy., 120 Units	68 212 75
2		Chassis Assy., 240V Units	68 212 85
3		Chassis Assy., 100V Units	68 212 95
4		Chassis, Controller (Weldment)	68 215 10
5		Latch Assy., Left	68 207 80
6		Latch Assy., Right	68 207 81
7		Heater, 120V	68 208 25
8	Heater, 240V	68 208 26	
9	Heater 100V	68 208 27	
10	Baffle/Plate, Heater	68 208 20	
11		Spacer, Heater Plate	26 516 05
12		Plate, Stiffener	68 204 21
13		Gasket	26 503 00
14		Plug, Thermostat	12 512 01
15		Gasket	26 501 00
16	B1	Motor Replacement Kit, 120V	68 903 80
17	B1	Motor Replacement Kit, 220V - <sup>STOCK</sup> 2631-73	68 903 81
18	B1	Motor Replacement Kit, 100V	68 903 82
19		Impeller <i>6141640.</i>	68 204 31
20		Adapter, Impeller	68 204 33
21	RT1A & B	Dual Thermistor Assy., Hi-Temp Alarm	68 214 70
22		Not Used	
23		Post, Bumper	68 215 12
24		Not Used	
25	T1	Power Transformer Assy., 120V	68 206 71
26	T1	Power Transformer Assy., 240V	68 206 77
27	T1	Power Transformer Assy., 100V	68 206 81
28		Not Used	
29	J14	Connector Assy., Power	68 205 81
30	J7	Receptacle Assy., Air Temperature Probe	68 209 86
31		Not Used	
32	RT4	Thermistor Assy., Air Flow	68 214 80
33		Not Used	
34	CB1	Circuit Breaker, Sgl. Pole, 5 amp (100 and 120 Vac Units)	17 BH 150
35		Circuit Breaker, Sgl. Pole, 5 amp (240 Vac Units)	17 BH 150
36		Button, Plug	22 059 60
37		Label, Heater Caution	68 208 30
38		Not Used	

\*Used only on Jakes Motors.

MOTOR MODIFICATION: 11/93

(Change 3)

6-17

USE BIKILA-CE AND CAPACITORS

ALSO USE BRASS

SMIA

**TABLE 6.5 MODEL C82 CONTROLLER, PARTS LIST (SHEET 2 of 3)**

PART NO. 68 217 70, 120V, ENGLISH  
PART NO. 68 217 80, 240V, ENGLISH  
PART NO. 68 217 90, 100V, JAPANESE  
PART NO. 68 217 83, 240V, GERMAN

PART NO. 68 217 71, 120V, SPANISH  
PART NO. 68 217 81, 240V, SPANISH  
PART NO. 68 217 72, 120V, FRENCH  
PART NO. 68 217 82, 240V, FRENCH

ITEM NO.	REFERENCE DESIGNATION	DESCRIPTION	PART NO.
30		Clip, Cord	17 725 44
31		Not Used	
32		Button, Plug	22 035 40
33		Scr, 8-32 x 5/8 TR, PH, SS	99 032 57
34		Scr, 10-32 x 1/2 TR, PH, SS	99 042 01
35		Scr, 8-32 x 3/4 TR, PH, SS	99 032 85
36		Scr, 4-40 x 3/8 TR, PH, SS	99 011 07
37		Scr, 6-32 x 3/4 TR, PH, SS	99 024 69
38		Nut, 4-40 HX, "KEPS", S, CA	99 103 33
39		Nut, 6-32 HX "KEPS", S, CAD, PL	99 105 34
40		Not Used	
41		Nut, 3/8-24, HX, JAM, SS	99 111 68
42		Nut, 3/8-24, HX, BR, NI, THIN	99 111 80
43		Wshr, LK, SP, #10, S CA	99 124 16
44		Wshr, No. 7/16 LK SHI S CA	99 127 41
45		Wshr, 3/8 FL, SS, .064 THK	99 126 70
46		Wshr, Fibre	17 803 40
47		Label, Voltage, 120V (Not Shown)	68 204 40
		Label, Voltage 240V (Not Shown)	68 204 41
		Label, Voltage 100V (Not Shown)	68 204 42
48		Wshr, 3/8 LK SHI, S, CA	99 126 93
49		Wshr, No. 8, LK, SHI, S4	99 122 92
50		Nut, Hex, Thin, Electrical	99 115 20
51		Wshr, Fibre	99 127 69
52		Wshr, 1/2 ID x 11/16 OD x .015 NYL	99 127 96
53**		Scr, 6-32 SE SK SS CP x 1/8 LG	99 022 17
54		Wshr, LK, EXT, #10 SS	99 123 94
55		Scr, 4-40 x 3/8 TR, PH, SS	99 011 07
56	K1	Relay, Solid State (100 and 120 Vac)	17 652 70
	K1	Relay, Solid State (240 Vac)	17 652 78
57		Scr, 10-32 x 3/8 TR, PH, SS	99 041 27
58		Front Panel Assy., Cont. (Refer to Table 6.7 for Parts Breakdown)	
59		Not Used	
60		Handle, Latch	68 215 15
61		Bushing	68 215 25
62		Spring, Compression	20 016 03

\*\*Used only with item 13.

**TABLE 6.5 MODEL C82 CONTROLLER, PARTS LIST (SHEET 3 of 3)**

PART NO. 68 217 70, 120V, ENGLISH	PART NO. 68 217 71, 120V, SPANISH
PART NO. 68 217 80, 240V, ENGLISH	PART NO. 68 217 81, 240V, SPANISH
PART NO. 68 217 90, 100V, JAPANESE	PART NO. 68 217 72, 120V, FRENCH
PART NO. 68 217 83, 240V, GERMAN	PART NO. 68 217 82, 240V, FRENCH

ITEM NO.	REFERENCE DESIGNATION	DESCRIPTION	PART NO.
63		Pawl, Latch	68 215 20
64		Ring, Retaining, WAL 5103-25	99 181 45
65		Pin, Spring, 3/32 Dia, x 1.00 LG	99 142 78
66		AC Line Cord, 120V (Not Shown)	17 AZ 100
		AC Line Cord, 220V (Not Shown)	17 AZ 200
67		Air Temperature Probe (Not Shown)	68 209 80

C100/200  
PARTS LIST

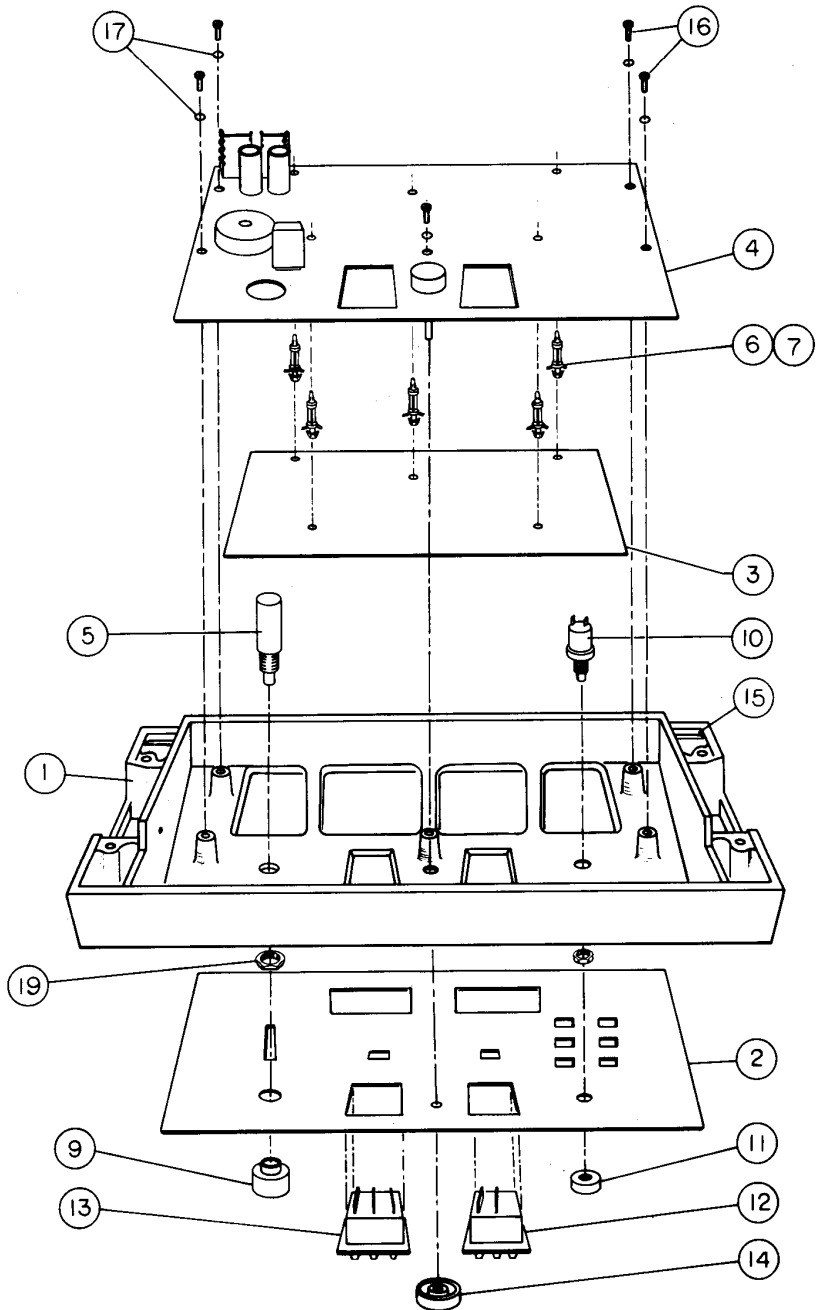

FIGURE 6.6 PARTS LOCATION DIAGRAM, MODEL C68 CONTROLLER, FRONT PANEL

**TABLE 6.6 MODEL C68 CONTROLLER FRONT PANEL, PARTS LIST**

PART NO. 68 211 75 (English Label)  
 PART NO. 68 211 76 (Spanish Label)  
 PART NO. 68 211 77 (French Label)  
 PART NO. 68 211 78 (German Label)  
 PART NO. 68 211 79 (Japanese Label)

REFERENCE NO.	DESIGNATION	DESCRIPTION	ITEM PART NO.
1		Housing, Controller	68 215 00
2		Nameplate, English	68 215 65
		Nameplate, Spanish	68 215 66
		Nameplate, French	68 215 67
		Nameplate, German	68 215 68
		Nameplate, Japanese	68 215 69
3	PCB1	Display (LED) Board	68 350 71
4	PCB2	Temp Cont & Alarm Logic Board	68 351 71
5	S1	Power Switch, Replacement Kit	68 901 73
6		Support, PCB (P/O Item 3)	17 AZ 534
7		Scr, 6-32 x 1/4 TR, PH, SS (P/O item 3)	99 022 72
8		Not Used	
9		Guard, Switch, Replacement Kit	68 901 74
10	S2	Reset Switch Assy.	68 210 75
11		Guard, Switch	17 061 88
12	S5	Skin Temp Switch Assy.	68 203 70
13	S4	Air Temp Switch Assy.	68 203 71
14		Knob, Instr., Skirted, Pointer	17 061 89
15		Gasket, Front Panel	68 215 40
16		Scr, 6-32 x 3/8 RD, PH, SS	99 023 26
17		Wshr, No. 6 LK, SHI, S4	99 122 19
18		Not Used	
19		Nut, Mounting, Switch (M14 x 1.0)	17 061 91

C100/200  
PARTS LIST

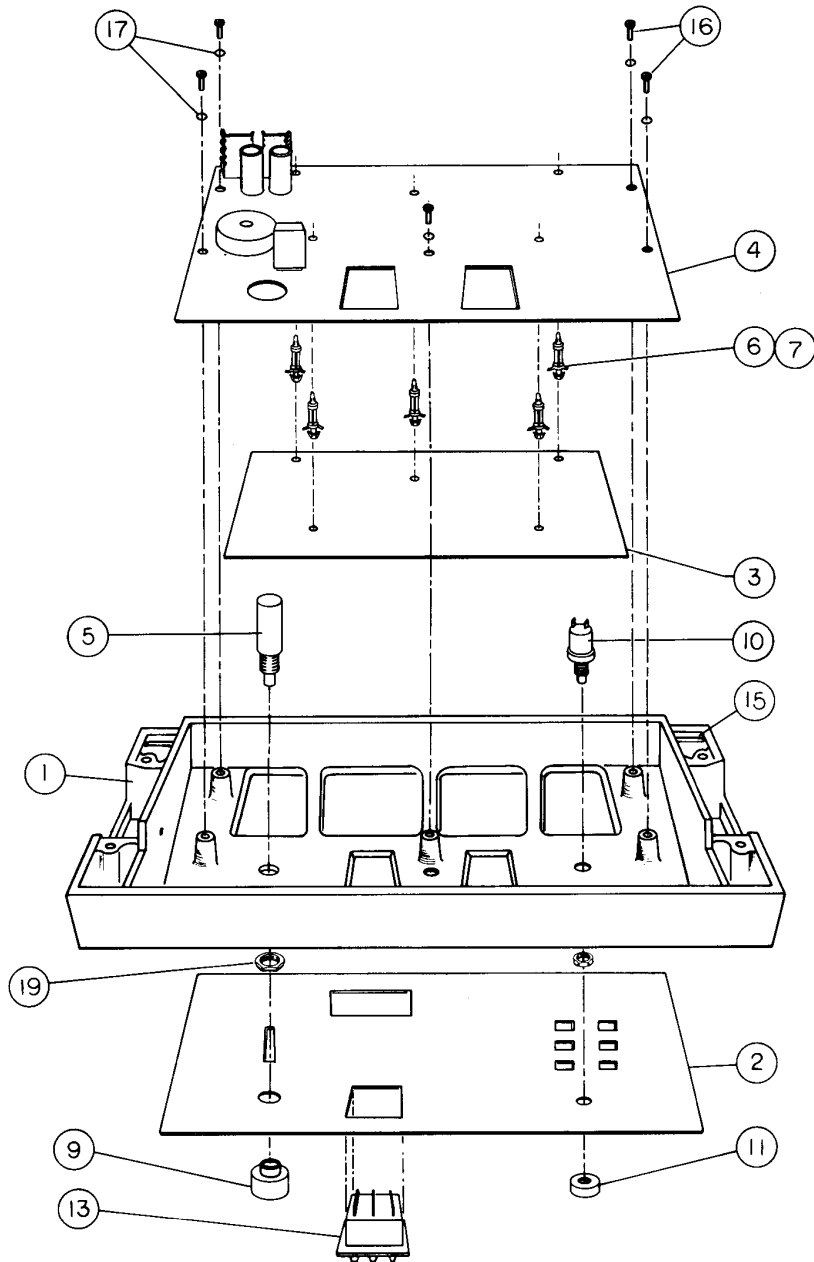

FIGURE 6.7 PARTS LOCATION DIAGRAM, MODEL C82 CONTROLLER, FRONT PANEL



**TABLE 6.7 MODEL C82 CONTROLLER FRONT PANEL, PARTS LIST**

PART NO. 68 216 70 (English Label)  
 PART NO. 68 216 71 (Spanish Label)  
 PART NO. 68 216 72 (French Label)  
 PART NO. 68 216 73 (German Label)  
 PART NO. 68 216 74 (Japanese Label)

ITEM NO.	REFERENCE DESIGNATION	DESCRIPTION	PART NO.
1		Housing, Controller	68 215 00
2		Nameplate, English	68 216 30
		Nameplate, Spanish	68 216 31
		Nameplate, French	68 216 32
		Nameplate, German	68 216 33
3	PCB1	Display (LED) Board	68 350 75
4	PCB2	Temp Cont & Alarm Logic Board	68 351 75
5	S1	Power Switch Replacement Kit	68 901 73
6		Support, PCB (P/O Item 3)	17 AZ 534
7		Scr, 6-32 x 1/4 TR, PH, SS (P/O item 3)	99 022 72
8		Not Used	
9		Guard, Switch, Replacement Kit	68 901 74
10	S2	Reset Switch Assy.	68 210 75
11		Guard, Switch	17 061 88
12		Not Used	
13	S4	Air Temp Switch Assy.	68 203 71
14		Not Used	
15		Gasket, Front Panel	68 215 40
16		Scr, 6-32 x 3/8 RD, PH, SS	99 023 26
17		Wshr, No. 6 LK, SHI, S4	99 122 19
18		Not Used	
19		Nut, Mounting, Switch (M14 x 1.0)	17 061 91

DO NOT LOCATE COMPONENTS IN SHADED AREAS.  
(FRONT PNL RIB CLEARANCE)

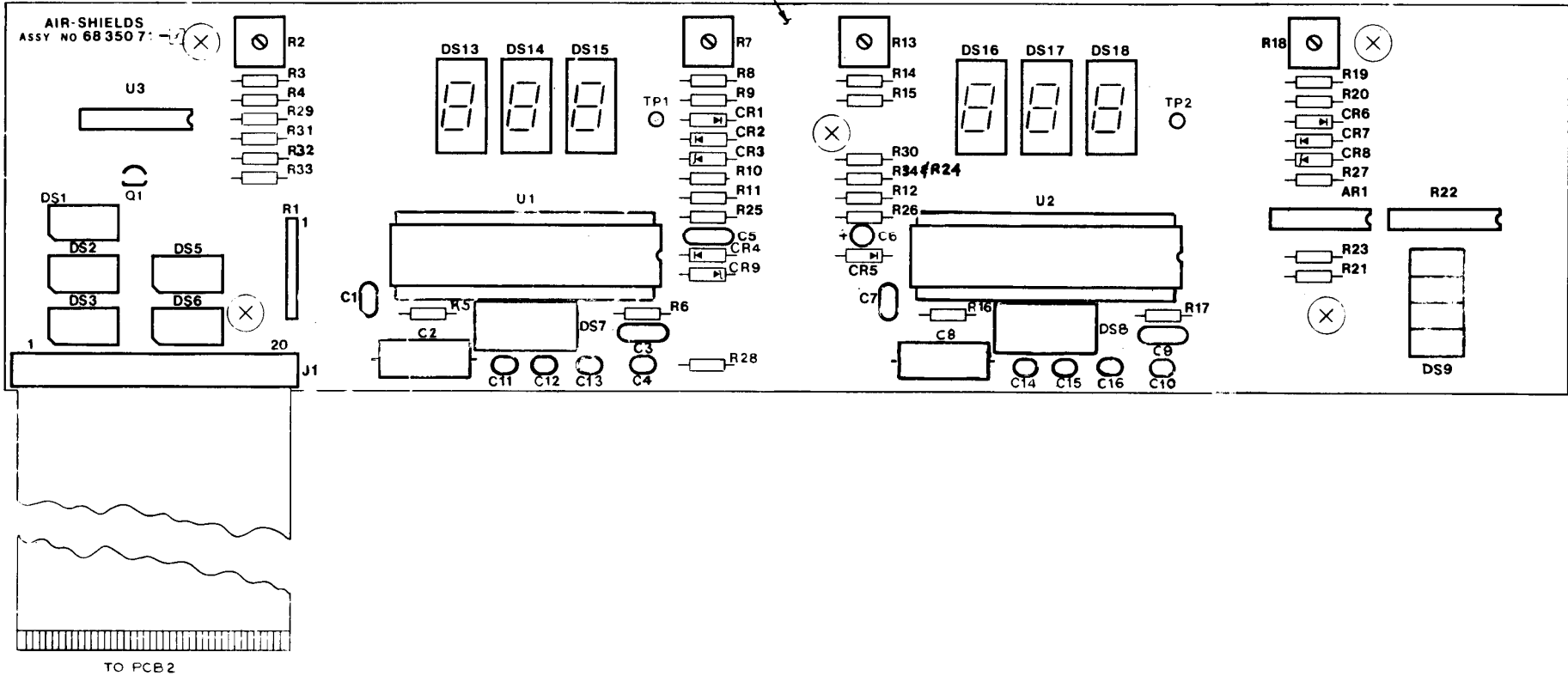

FIGURE 6.8 PARTS LOCATION DIAGRAM, DISPLAY BOARD PCB1 -  
MODEL C68 CONTROLLER

**TABLE 6.8 PCB1, MODEL C68 CONTROLLER DISPLAY BOARD, PARTS LIST  
(SHEET 1 of 2)**

PART NO. 68 350 71

ITEM NO.	REFERENCE DESIGNATION	DESCRIPTION	PART NO.
1		Not Used	
2		Not Used	
3		Not Used	
4		Not Used	
5		Not Used	
6		Not Used	
7		Not Used	
8		Not Used	
9		Not Used	
10		Not Used	
11		Support, PCB, INTL THD .50 LG	17 AZ 534
12		SC 6-32 x 1/4 TR, PH, SS	99 022 72
13	J1	Conn. Rcpt, PC Flat Cable, 20 Posn	17 BP 074
14		Not Used	
15*	C3, C9	Cap, 1.0 MFD, 20%, 50V	17 BF 224
	C3, C9	Cap, 0.10 MFD, 20%, 50V (Rev. 1 PCB Only)	17 430 57
16*	C1, C7	Cap, 0.047 MFD 10%, 50V	17 BF 257
	C1, C7	Cap, 0.01 MFD, +80 MFD, -20%, 50V (Rev. 1 & 2 PCB Only)	17 BF 388
17	C11, C12, C13, C14, C15, C16,	Cap, 0.001 MFD, 10%, 50V	17 BF 377
18	C5,	Cap, 0.10 MFD, 20%, 50V	17 430 57
19	C2, C8	Cap, 0.22 MFD, 5%, 100V	17 AY 085
20*	C4, C10	Cap, 100 PFD, 10%, 50V	17 BF 365
	C4, C10	Cap, 0.001 MFD, 10%, 50V (Rev. 1 PCB Only)	17 BF 377
21	C6	Cap, 3.9 PFD, 10%, 15V	17 AW 223
22		Not Used	
23*	CR1, CR6	Diode, 1N34A	17 500 20
	CR1, CR6	Diode, 1N914 (Rev. 1 PCB Only)	17 AR 500
24		Not Used	
25	CR2, CR4, CR5, CR7	Diode, 1N914	17 AR 500
26*	CR3, CR8, CR9 CR9	Diode, Zener, 1N752A, 5.6V Diode, Zener, 1N4740A, 10V ± 5%, 1W (Rev. 1 & 2 PCB Only)	17 502 60 17 500 10
27	U3	Integ. Crkt, 4050	17 630 01
28	AR1	Integ. Crkt, LM324AN	17 631 45
29	U1, U2	Integ, Crkt, 7107	17 630 75
30	DS13, DS14, DS15, DS16, DS17, DS18	Display, LED, Orn	17 BE 247
31	DS1, DS2, DS3, DS5, DS6	Lamp, LED, Red	17 807 00
32	DS9	Lamp, LED, Yel	17 BE 252

\* See page 2 at the front of this manual for information on modification kits.

**TABLE 6.8 PCB1, MODEL C68 CONTROLLER DISPLAY BOARD, PARTS LIST  
(SHEET 2 of 2)**

PART NO. 68 350 71

ITEM NO.	REFERENCE DESIGNATION	DESCRIPTION	PART NO.
33 34 35	DS7, DS8  R2, R7, R13 R18	Lamp, LED, Green Not Used Res, Var, 500 ohms, 0.5W, VRT ADJ Not Used Not Used	17 BE 240  17 AN 011
38 39 40 41 42	R1 R22  R10 R29, R30, R33	Res. Network, SIP 470 ohms, 5%, 1/8W Res, Network, DIP, 390 ohms, 2% 1/75W Not Used Res, 51 ohms, 5%, 1/4W Res, 220 ohms, 5%, 1/4W	17 AU 025 17 AU 560  17 AA 124 17 AA 169
43 44 45* 46 47	R28 R27 R27 R24, R34 R24  R34 R32	Res, 300 ohms, 5%, 1/4W Res, 33K, 5%, 1/4W Res, 20K, 5%, 1/4W (Rev. 1 PCB Only) Res, 330 ohms, 5%, 1/4W Res, 47 Ohms, 5%, 1/4W (Rev. 1 & 2 PCB Only) Not Used (Rev. 1 & 2 PCB Only) 5.1K, 5%, 1/4W Not Used	17 AA 178 17 AA 325 17 AA 310 17 AH 721  17 AA 121 17 AA 268
48 49 50 51 52	R23 R3, R14 R8, R19 R21 R12, R26	Res, 182 ohms, 1%, 1/8W Res, 1.50K, 1%, 1/8W Res, 2.00K, 1%, 1/8W Res, 3.09K, 1%, 1/8W Res, 10.00K, 1%, 1/8W	17 AF 121 17 AF 209 17 AF 221 17 AF 239 17 AF 288
53 54 55* 56* 57	R11, R25, R31 R4, R9, R15, R20 R6, R17 R6, R17 R5, R16 R5, R16	Res, 15.00K, 1%, 1/8W  Res, 20.00K, 1%, 1/8W Res, 100K, 1%, 1/8W Res, 36.5K, 1%, 1/8W (Rev. 1 & 2 PCB Only) Res, 475K, 1%, 1/8W Res, 2.21M, 1%, 1/8W (Rev. 1 & 2 PCB Only) Not Used	17 AF 305  17 AF 317 17 AF 384 17 AF 342 17 AF 449 17 AF 513
58 59 60	 Q1	Not Used Transistor, 2N4124 Cable, Flat, Flex Crkt, 20 Posn	 17 625 58 17 730 82

\* See page 2 at the front of this manual for information on modification kits.

C100/200  
PARTS LIST

(This page is intentionally left blank.)

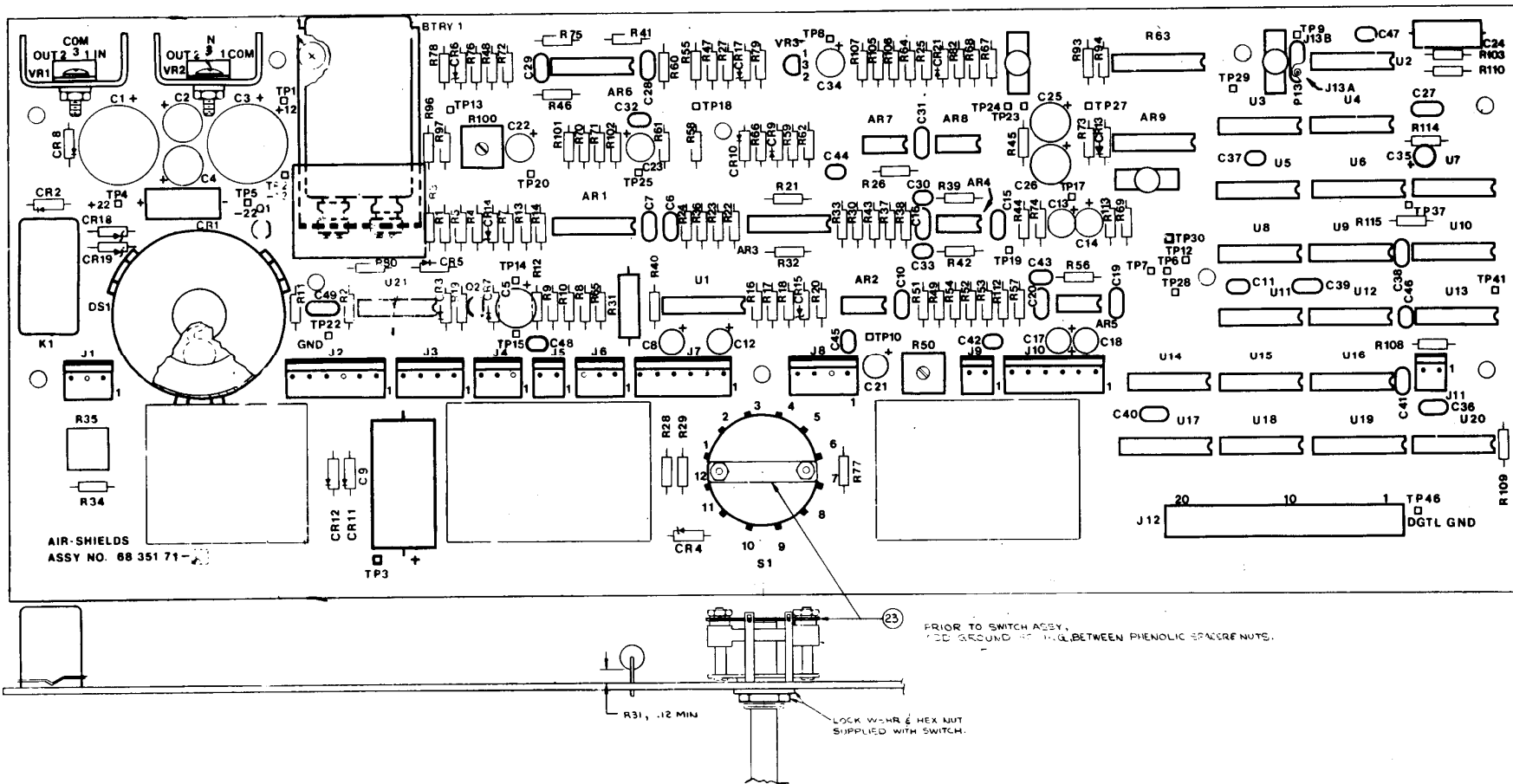

**FIGURE 6.9 PARTS LOCATION DIAGRAM, TEMPERATURE CONTROL AND ALARM LOGIC PCB2 - MODEL C68 CONTROLLER**

**TABLE 6.9 PCB2, MODEL C68 CONTROLLER TEMP. CONT. AND ALARM LOGIC,  
PARTS LIST (SHEET 1 of 5)**

PART NO. 68 351 71

ITEM NO.	REFERENCE DESIGNATION	DESCRIPTION	PART NO.
1		Not Used	
2		Not Used	
3		Not Used	
4		Not Used	
5		Not Used	
6		Not Used	
7		Not Used	
8		Not Used	
9		Not Used	
10		Not Used	
11		Heat Sink	17 061 14
12		Insulator, Transistor, Thrm Cndct	17 061 19
13		Holder, Btry, PCB Mtg.	17 806 99
14		Battery, 7.2V, Rechargeable	17 806 98
15		Socket, Transducer	17 652 71
16		Transducer, Tone	17 652 72
17		Case, Modified, Btry	68 351 36
18		Scr, 4-40 x 3/8 TR, PH, SS	99 011 07
19		Nt. 4-40 HX, KEPS, S, CAD	99 103 33
20		Wshr, No. 4 FL, NY	99 121 23
21		Scr, 4-40 x 1/4 TR, PH, SS	99 010 56
22		Nt, 4-40 HX, SS	99 103 35
23		Strap, Grounding	68 351 30
24	C30, C33, C42 C43, C44, C45, C47, C49	Cap, 0.001 MFD, 10%, 50V	17 BF 377
25	C6, C7, C10, C15, C16, C19, C20, C27, C28, C29, C31, C36, C38, C39, C40, C41	Cap, 0.01 MFD +80%, -20%, 50V	17 BF 388
26	C11, C32, C37 C46, C48	Cap, 0.10 MFD, 20%, 50V	17 BF 217
27	C35	Cap, 0.33 MFD, 10%, 50V	17 AW 206
28	C24	Cap, 0.56 MFD, 5%, 100V	17 AY 100

C100/200  
PARTS LIST

**TABLE 6.9 PCB2, MODEL C68 CONTROLLER TEMP. CONT. AND ALARM LOGIC,  
PARTS LIST (SHEET 2 of 5)**

PART NO. 68 351 71

ITEM NO.	REFERENCE DESIGNATION	DESCRIPTION	PART NO.
29	C8, C12, C13, C14, C17, C18, C21, C22, C23, C34	Cap, 4.7 MFD, 10% 35V	17 AW 224
30	C2, C4, C5, C25, C26	Cap, 56 MFD, 10%, 15V	17 AW 257
31	C1	Cap, 1000 MFD, +50 -10%, 35V	17 AW 853
32	C9	Cap, 1000 MFD, +50 -20%, 16V	17 405 34
33	C3	Cap, 470 MFD, +50 -10%, 35V	17 AW 833
34		Not Used	
35		Not Used	
36		Not Used	
37		Not Used	
38		Not Used	
39		Not Used	
40		Not Used	
41	J5, J9, J11	Conn, Rcpt, Male 2 Posn	17 BP 025
42	J1, J4, J6	Conn, Rcpt, Male 3 Posn	17 BP 026
43	J3, J8	Conn, Rcpt, Male, 4 Posn	17 BP 027
44		Not Used	
45	J2, J7	Conn, Rcpt, Male, 6 Posn	17 BP 029
46	J12	Conn, Rcpt, Female, 20 Posn	17 BP 074
47		Not Used	
48		Not Used	
49		Not Used	
50		Not Used	
51	CR3, CR5, CR7, CR8, CR9, CR10, CR13, CR21	Diode, 1N914	17 AR 500
52	CR14	Diode, Zener, 1N4744A, 15V	17 502 38
53	CR2, CR11, CR12	Diode, 1N4001	17 AS 000
54	CR15	Diode, Zener, 1N4736A, 6.8V	17 501 68
55	CR4	Diode, Zener, 1N4730A, 3.9V	17 AR 005
56	CR6, CR17	Diode, Zener, 1N5231B, 5.1V	17 502 08
57	CR18, CR19	Diode, Zener, 1N4742A, 12.0V	17 502 21
58		Not Used	
59		Not Used	
60		Not Used	



**TABLE 6.9 PCB2, MODEL C68 CONTROLLER TEMP. CONT. AND ALARM LOGIC,  
PARTS LIST (SHEET 3 of 5)**

PART NO. 68 351 71

ITEM NO.	REFERENCE DESIGNATION	DESCRIPTION	PART NO.
61	U2, U7, U15	I.C. 4001	17 629 75
62	U9, U11, U13, U18	I.C. 4011	17 629 77
63	U4, U5, U8, U10, U12	I.C. 4013	17 629 57
64	U14	I.C. 4023	17 629 83
65	U3	I.C. 4024	17 629 84
66	U20	I.C. 4025	17 629 85
67	U17, U19	I.C. 4027	17 629 86
68	U6	I.C. 4520	17 631 34
69	U16, U21	I.C. 4069	17 629 92
70	U1	I.C. 4066	17 630 76
71	AR2,	I.C. 1458	17 629 36
72	AR5, AR7	I.C. 3302	17 629 58
73	AR1, AR3, AR9	I.C. 3403	17 629 70
74	AR6	I.C. TL081CP	17 630 77
75	AR8	I.C. 358A	17 631 85
76	AR4	Not Used	
77		Not Used	
78		Not Used	
79		Not Used	
80		Not Used	
81	R35, R50	Res, Var, 500 ohms, 0.5W, VRT ADJ	17 AN 011
82	R100	Res, Var, 20K, 0.5W, VRT ADJ	17 AN 021
83		Not Used	
84		Not Used	
85		Not Used	
86		Not Used	
87		Not Used	
88	P13	Conn, Jumper Plug, Female	17 730 12
89		Not Used	
90		Not Used	
91	CR1	Rectifier, Bridge, 1.5A	17 AS 201
92		Not Used	
93		Not Used	
94	VR1	Rgltr, V, 78M12UC (+12V)	17 AT 003
95	VR2	Rgltr, V, 79M12AUC (-12V)	17 AT 013

C100/200  
PARTS LIST

**TABLE 6.9 PCB2, MODEL C68 CONTROLLER TEMP. CONT. AND ALARM LOGIC,  
PARTS LIST (SHEET 4 of 5)**

PART NO. 68 351 71

ITEM NO.	REFERENCE DESIGNATION	DESCRIPTION	PART NO.
96	VR3	Rgltr, V, 78L05AWC (+5V)	17 AT 041
97		Not Used	
98		Not Used	
99	K1	Relay, SPDT, 12V, 10A	17 652 66
100	R64	Res, 100 Ohm, 5%, 1/4W	17 AH 697
101	R11	Res, 160K, 5%, 1/4W	17 AH 851
102	R23, R65	Res, 5.1K, 5%, 1/4W	17 AH 779
103	R1, R27, R32, R48, R58, R67, R69, R70, R78, R82, R93, R94, R101, R107, R113, R80	Res, 10K, 5%, 1/4W	17 AH 793
104	R3	Res, 12K, 5%, 1/4W	17 AH 797
105	R79	Res, 20K, 5%, 1/4W	17 AH 807
106		Not Used	
107	R71, R76	Res, 51K, 5%, 1/4W	17 AH 827
108	R72, R75	Res, 100K, 5%, 1/4W	17 AH 841
109	R25	Res, 200K, 5%, 1/4W	17 AH 855
110	R68	Res, 2.2M, 5%, 1/4W	17 AH 905
111	R2	Res, 3.9M, 5%, 1/4W	17 AH 917
112	R31	Res, 120 Ohm, 5%, 2W	17 AD 151
113		Not Used	
114	R19	Res, 845 Ohm, 1%, 1/8W	17 AF 185
115	R29, R42, R43, R56, R57	Res, 2.00K, 1%, 1/8W	17 AF 221
116	R16	Res, 3.57K, 1%, 1/8W	17 AF 245
117	R55	Res, 4.02K, 1%, 1/8W	17 AF 250
118	R36, R51	Res, 4.12K, 1%, 1/8W	17 AF 251
119	R28, R66, R115	Res, 4.99K, 1%, 1/8W	17 AF 259
120	R4, R14, R45	Res, 6.04K, 1%, 1/8W	17 AF 267
121	R34, R49	Res, 8.87K, 1%, 1/8W	17 AF 283
122	R17, R24, R30, R37, R38, R40, R52, R53, R97, R102, R105, R106, R109, R112	Res, 10.00K, 1%, 1/8W	17 AF 288

**TABLE 6.9 PCB2, MODEL C68 CONTROLLER TEMP. CONT. AND ALARM LOGIC,  
PARTS LIST (SHEET 5 of 5)**

PART NO. 68 351 71

ITEM NO.	REFERENCE DESIGNATION	DESCRIPTION	PART NO.
123	R47	Res, 10.20K, 1%, 1/8W	17 AF 289
124	R7, R20*, R59	Res, 14.00K, 1%, 1/8W	17 AF 302
125	R44, R77, R21	Res, 15.00K, 1%, 1/8W	17 AF 305
126	R8, R13, R22, R33, R60*, R62, R96, R74	Res, 20.00K, 1%, 1/8W	17 AF 317
127	R26	Res, 24.90K, 1%, 1/8W	17 AF 326
128	R39, R54	Res, 31.60K, 1%, 1/8W	17 AF 336
129**	R20	Res, 13.7K, 1%, 1/8W	17 AF 301
130	R10	Res, 45.30K, 1%, 1/8W	17 AF 351
131	R18, R61, R5	Res, 49.90K, 1%, 1/8W	17 AF 355
132	R9	Res, 60.40K, 1%, 1/8W	17 AF 363
133	R41, R46, R110	Res, 100.00K, 1%, 1/8W	17 AF 384
134	R73	Res, 249.00K, 1%, 1/8W	17 AF 422
135**	R60	Res, 17.8K, 1%, 1/8W	17 AF 312
136	R12, R108, R114	Res, 1.00M, 1%, 1/8W	17 AF 480
137	R103	Res, 1.18M, 1%, 1/8W	17 AF 487
138	R63	Res, Ntwk, 10K, 2%, 1.75W, 16 DIP	17 AU 530
139	S1	Switch, Rotary, 4 PDT	17 682 05
140		Not Used	
141	J13A, J13B	Contact, Male Pin, PC Mtg. .040 DIA	17 730 13
142	TP6, TP7 TP10, TP12 TP13, TP14 TP15, TP17 TP18, TP19 TP20, TP22 TP23, TP24 TP25, TP27 TP28, TP29 TP30, TP46	Socket Lead	17 731 09
143		Not Used	
144		Not Used	
145	Q1	Transistor, A8T404-A, PNP	17 627 86
146	Q2	Transistor, 2N4124, NPN	17 625 58

\* PCB2 Rev. 2 and below unless Retrofit Kit P/N 68 902 70 has been installed. If kit is installed, see items 129 (R20) and 135 (R60) for value and P/N of resistors. See also page 2.

\*\* PCB2 Rev. 3 and above.

DO NOT LOCATE COMPONENTS IN SHADED AREAS.  
(FRONT FNL RIB CLEARANCE)

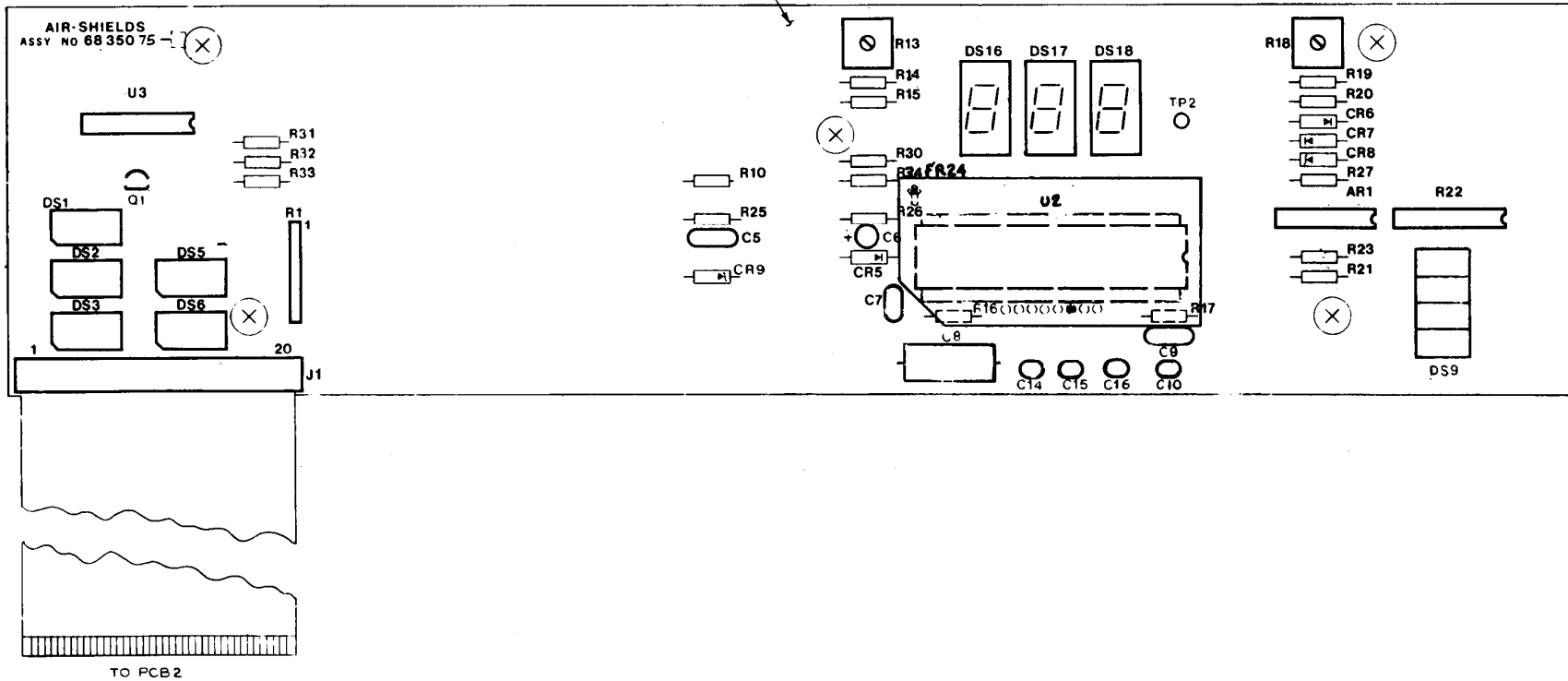

FIGURE 6.10 PARTS LOCATION DIAGRAM, DISPLAY BOARD PCB1 -  
MODEL C82 CONTROLLER

**TABLE 6.10 PCB1, MODEL C82 CONTROLLER DISPLAY BOARD, PARTS LIST  
(SHEET 1 of 2)**

PART NO. 68 350 75

ITEM NO.	REFERENCE DESIGNATION	DESCRIPTION	PART NO.
1		Not Used	
2		Not Used	
3		Not Used	
4		Not Used	
5		Not Used	
6		Not Used	
7		Not Used	
8		Not Used	
9		Not Used	
10		Not Used	
11		Support, PCB, INTL THD .50 LG.	17 AZ 534
12		Screw, 6-32 x 1/4 TR, PH, SS	99 022 72
13	J1	Conn, Rcpt, PC Flat Cable, 20 Posn.	17 BP 074
14		Not Used	
15		Not Used	
16*	C7	Cap, 0.047 MFD, 10%, 50V	17 BF 257
	C7	Cap, 0.01 MFD, +80%, -20%, 50V (Rev. 4 and below PCB Only)	17 BF 388
17	C14, C15, C16	Cap, .001 MFD, 10%, 50V	17 BF 377
18	C5	Cap, .10 MFD, 20%, 50V	17 430 57
19	C8	Cap, .22 MFD, 5%, 100V	17 AYO 85
20*	C10	Cap, 100 PFD, 10%, 50V	17 BF 365
	C10	Cap, 0.001 MFD, 10%, 50V (Rev. 4 and below PCB Only)	17 BF 377
21	C6	Cap, 3.9 MFD, 10%, 15V	17 AW 223
22*	C9	Cap, 1.0 MFD, 20%, 50V	17 BF 224
23*	CR6	Diode, IN34A	17 500 20
	C9	Cap, 0.10 MFD, 20%, 50V (Rev. 3 and below PCB Only)	17 430 57
24		Not Used	
25	CR5, CR7	Diode, 1N914	17 AR 500
26*	CR8, CR9	Diode, Zener, 1N752A, 5.6V	17 502 60
	CR9	Diode, Zener, IN4740A, 10V ± 5%, 1W (Rev. 4 and below PCB Only)	17 500 10
27	U3	Integ. Crkt. 4050	17 630 01
28	AR1	Integ. Crkt. LM324AN	17 631 45
29	U2	Integ. Crkt. 7107	17 630 75
30	DS16, DS17, DS18	Display, LED, Orange	17 BE 247
31	DS1, DS2, DS3		
	DS5, DS6	Lamp, LED, Red	17 807 00
32	DS9	Lamp, LED, Yellow	17 BE2 52

\* See page 2 at front of this manual for information on Modification Kits.

C100/200  
PARTS LIST

**TABLE 6.10 PCB1, MODEL C82 CONTROLLER DISPLAY BOARD, PARTS LIST  
(SHEET 2 of 2)**

PART NO. 68 350 75

ITEM NO.	REFERENCE DESIGNATION	DESCRIPTION	PART NO.
33 34 35 36 37	R13, R18	Not Used Not Used Res, Var, 500 ohms, .5W, Vrt Adj Not Used Not Used	17 AN 011
38 39 40 41 42	R1 R22 R10 R30, R33	Res Network, Sip, 470 ohms, 5%, 1/8W Res Network, Dip, 390 ohms, 2%, 1.75W Not Used Res, 51 ohms, 5%, 1/4W Res, 220 ohms, 5%, 1/4W	17 AU 025 17 AU 560 17 AA 124 17 AA 169
43 44 45* 46 47	R27 R27 R24, R34 R24 R34 R32	Not Used Res, 33K, 5%, 1/4W Res, 20K, 5%, 1/4W (Rev. 3 and below PCB Only) Res, 330 ohms, 5%, 1/4W Res, 47 Ohms, 5%, 1/4W (Rev. 4 and below PCB Only) Not Used (Rev. 4 and below PCB Only) Res, 5.1K, 5%, 1/4W Not Used	17 AA 325 17 500 10 17 AH 721 17 AA 121 17 AA 268
48 49 50 51 52	R23 R14 R19 R21 R26	Res, 182 ohms, 1%, 1/8W Res, 1.50K, 1%, 1/8W Res, 2.00K, 1%, 1/8W Res, 3.09K, 1%, 1/8W Res, 10.00K, 1%, 1/8W	17 AF 121 17 AF 209 17 AF 221 17 AF 239 17 AF 288
53 54 55* 56* 57	R25, R31 R15, R20 R17 R17 R16 R16	Res, 15.00K, 1%, 1/8W Res, 20.00K, 1%, 1/8W Res, 100K, 1%, 1/8W Res, 36.5K, 1%, 1/8W (Rev. 4 and below PCB Only) Res, 475K, 1%, 1/8W Res, 2.21M, 1%, 1/8W (Rev. 4 and below PCB Only) Not Used	17 AF 305 17 AF 317 17 AF 384 17 AF 342 17 AF 449 17 AF 513
58 59 60	Q1	Not Used Transistor, 2N4124 Cable, Flat, Flex Crkt, 20 Posn	17 625 58 17 730 82

\* See page 2 at front of this manual for information on Modification Kits.

C100/200  
PARTS LIST

(This page is intentionally left blank.)

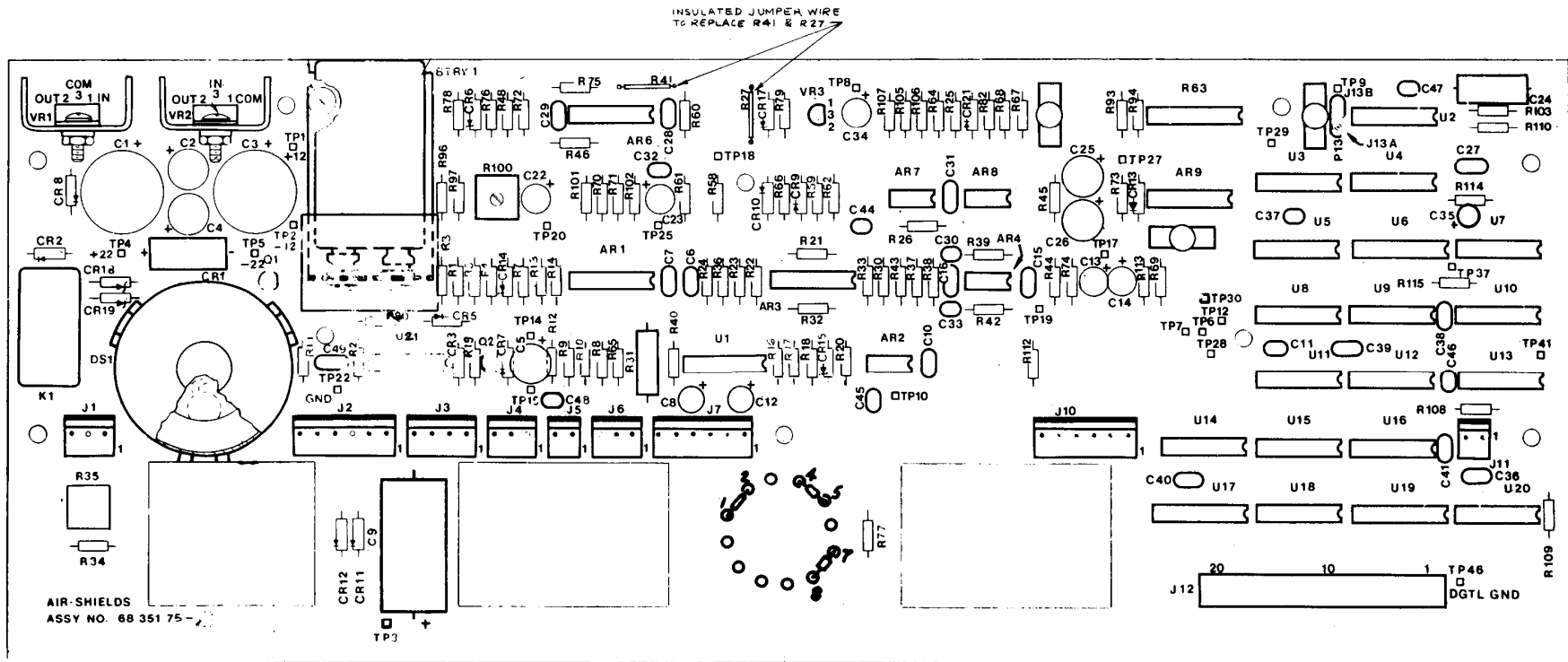

FIGURE 6.11 PARTS LOCATION DIAGRAM, TEMPERATURE CONTROL AND ALARM LOGIC PCB2 – MODEL C82 CONTROLLER

(change 1)



**TABLE 6.11 PCB2, MODEL C82 CONTROLLER TEMP. CONT. AND ALARM LOGIC,  
PARTS LIST (SHEET 1 of 5)**

PART NO. 68 351 75

ITEM NO.	REFERENCE DESIGNATION	DESCRIPTION	PART NO.
1		Not Used	
2		Not Used	
3		Not Used	
4		Not Used	
5		Not Used	
6		Not Used	
7		Not Used	
8		Not Used	
9		Not Used	
10		Not Used	
11		Heat Sink	17 061 14
12		Insulator, Transistor, Thrm Cndct	17 061 19
13		Holder, Btry, PCB Mtg	17 806 99
14		Battery, 7.2V, Rechargeable	17 806 98
15		Socket, Transducer	17 652 71
16		Transducer, Tone	17 652 72
17		Case, Modified, Btry	68 351 36
18		Screw, 4-40 x 3/8 TR, PH, SS	99 011 07
19		NT. 4-40 HX, KEPS, S, CAD	99 103 33
20		Wshr, No. 4 FL, NY	99 121 23
21		Scr, 4-40 x 1/4 TR, PH, SS	99 010 56
22		Nut, 4-40 HX, SS	99 103 35
23		Not Used	
24	C30, C33 C44, C45, C47, C49	Cap, 0.001 Mfd, 10%, 50V	17 BF 377
25	C6, C7, C10, C15, C16, C27 C28, C29, C31 C36, C38, C39 C40, C41	Cap, 0.01 Mfd +80% -20%, 50V	17 BF 388
26	C11, C32, C37, C46, C48	Cap, 0.10 Mfd, 20%, 50V	17 BF 217
27	C35	Cap, 0.33 Mfd, 10%, 50V	17 AW 206
28	C24	Cap, 0.56 Mfd, 5%, 100V	17 AY 100
29	C8, C12, C13, C14, C22, C23, C24	Cap, 4.7 Mfd, 10%, 35V	17 AW 224
30	C2, C4, C5, C25, C26	Cap, 56 Mfd, 10%, 15V	17 AW 257

C100/200  
PARTS LIST

**TABLE 6.11 PCB2, MODEL C82 CONTROLLER TEMP. CONT. AND ALARM LOGIC,  
PARTS LIST (SHEET 2 of 5)**

PART NO. 68 351 75

ITEM NO.	REFERENCE DESIGNATION	DESCRIPTION	PART NO.
31	C1	Cap, 1000 Mfd, +50% -10%, 35V	17 AW 853
32	C9	Cap, 1000 Mfd +50% -10%, 16V	17 405 34
33	C3	Cap, 470 Mfd, +50% -10%, 35V	17 AW 833
34		Not Used	
35		Not Used	
36		Not Used	
37		Not Used	
38		Not Used	
39		Not Used	
40		Not Used	
41	J5, J11	Conn, Rcpt, Male, 2 posn.	17 BP 025
42	J1, J4, J6	Conn, Rcpt, Male, 3 posn.	17 BP 026
43	J3	Conn, Rcpt, Male, 4 posn.	17 BP 027
44		Not Used	
45	J2, J7	Conn, Rcpt, Male, 6 posn.	17 BP 029
46	J12	Conn, Rcpt, Female, 20 posn.	17 BP 074
47		Not Used	
48		Not Used	
49		Not Used	
50		Not Used	
51	CR3, CR5, CR7, CR8, CR9, CR10, CR13, CR21	Diode, 1N914	17 AR 500
52	CR14	Diode, Zener, 1N4744A, 15V	17 502 38
53	CR2, CR11, CR12	Diode, 1N4001	17 AS 000
54	CR15	Diode, Zener, 1N4736A, 6.8V	17 501 68
55		Not Used	
56	CR6, CR17	Diode, Zener, 1N5231B, 5.1V	17 502 08
57	CR18, CR19	Diode, Zener, 1N4742A, 12.0V	17 502 21
58		Not Used	
59		Not Used	
60		Not Used	
61	U2, U7, U15	I.C. 4001	17 629 75
62	U9, U11, U13, U18	I.C. 4011	17 629 77
63	U4, U5, U8, U10, U12	I.C. 4013	17 629 57
64	U14	I.C. 4023	17 629 83
65	U3	I.C. 4024	17 629 84
66	U20	I.C. 4025	17 629 85

**TABLE 6.11 PCB2, MODEL C82 CONTROLLER TEMP. CONT. AND ALARM LOGIC,  
(SHEET 3 of 5)**

PART NO. 68 351 75

ITEM NO.	REFERENCE DESIGNATION	DESCRIPTION	PART NO.
67	U17, U19	I.C. 4027	17 629 86
68	U6	I.C. 4520	17 631 34
69	U16, U21	I.C. 4069	17 629 92
70	U1	I.C. 4056	17 630 76
71	AR2, AR7	I.C. 1458	17 629 36
72	AR1, AR3, AR9	I.C. 3302	17 629 58
73	AR6	I.C. 3403	17 629 70
74	AR8	I.C. TL081CP	17 630 77
75	AR4	I.C. 358A	17 631 85
76		Not Used	
77		Not Used	
78		Not Used	
79		Not Used	
80		Not Used	
81	R35	Res, Var, 500 ohms, .5W, Vrt Adj	17 AN 011
82	R100	Res, Var, 20K, .5W, Vrt Adj	17 AN 021
83		Not Used	
84		Not Used	
85		Not Used	
86		Not Used	
87		Not Used	
88	P13	Conn, Jumper Plug, Female	17 730 12
89		Not Used	
90		Not Used	
91	CR1	Rectifier, Bridge, 1.5A	17 AS 201
92		Not Used	
93		Not Used	
94	VR1	Rgltr, V, 78M12UC (+12V)	17 AT 003
95	VR2	Rgltr, V, 79M12AUC (-12V)	17 AT 013
96	VR3	Rgltr, V, 78L05AUC (+5V)	17 AT 041
97		Not Used	
98		Not Used	
99	K1	Relay, SPDT, 12V, 10A	17 652 66
100	R64	Res, 100 Ohm, 5%, 1/4W	17 AH 697
101	R11	Res, 160K, 5%, 1/4W	17 AH 851
102	R23, R65	Res, 5.1K, 5%, 1/4W	17 AH 779
103	R1, R32, R48 R58, R67, R69, R70, R78, R80, R82, R93, R94, R101, R107, R113	Res, 10K, 5%, 1/4W	17 AH 793

C100/200  
PARTS LIST

**TABLE 6.11 PCB2, MODEL C82 CONTROLLER TEMP. CONT. AND ALARM LOGIC.**

**PARTS LIST**

(SHEET 4 of 5)

PART NO. 68 351 75

ITEM NO.	REFERENCE DESIGNATION	DESCRIPTION	PART NO.
104	R3	Res, 12K, 5%, 1/4W	17 AH 797
105	R79	Res, 20K, 5%, 1/4W	17 AH 807
106		Not Used	
107	R71, R76	Res, 51K, 5%, 1/4W	17 AH 827
108	R72, R75	Res, 100K, 5%, 1/4W	17 AH 841
109	R25	Res, 200K, 5%, 1/4W	17 AH 855
110	R68	Res, 2.2M, 5%, 1/4W	17 AH 905
111	R2	Res, 3.9M, 5%, 1/4W	17 AH 917
112	R31	Res, 120 Ohm, 5%, 2W	17 AD 151
113		Not Used	
114	R19	Res, 845 Ohm, 1%, 1/8W	17 AF 185
115	R42, R43	Res, 2.00K, 1%, 1/8W	17 AF 221
116	R16	Res, 3.57K, 1%, 1/8W	17 AF 245
117		Not Used	
118	R36	Res, 4.12K, 1%, 1/8W	17 AF 251
119	R4, R66, R115	Res, 4.99K, 5%, 1/4W	17 AF 259
120	R14, R45	Res, 6.04K, 1%, 1/8W	17 AF 267
121	R34, R49	Res, 8.87K, 1%, 1/8W	17 AF 283
122	R17, R24, R30 R37, R38, R40 R97, R102, R105, R106, R109, R112	Res, 10.00K, 1%, 1/8W	17 AF 288
123		Not Used	
124	R7, R20*, R59	Res, 14.00K, 1%, 1/8W	17 AF 302
125	R21, R44, R77	Res, 15.00K, 1%, 1/8W	17 AF 305
126	R8, R13, R22, R33, R60*, R62, R74, R96	Res, 20.00K, 1%, 1/8W	17 AF 317
127	R26	Res, 24.90K, 1%, 1/8W	17 AF 326
128	R39	Res, 31.60K, 1%, 1/8W	17 AF 336
129**	R20	Res, 13.7K, 1%, 1/8W	17 AF 301
130	R10	Res, 45.30K, 1%, 1/8W	17 AF 351
131	R5, R18, R61	Res, 49.90K, 1%, 1/8W	17 AF 355
132	R9	Res, 60.40K, 1%, 1/8W	17 AF 363
133	R46, R110	Res, 100.00K, 1%, 1/8W	17 AF 384
134	R73	Res, 249.00K, 1%, 1/8W	17 AF 422
135**	R60	Res, 17.8K, 1%, 1/8W	17 AF 312
136	R12, R108, R114	Res, 1.00M, 1%, 1/8W	17 AF 480

**TABLE 6.11 PCB2, MODEL C82 CONTROLLER TEMP. CONT. AND ALARM LOGIC,**

**PARTS LIST**

**(SHEET 5 of 5)**

PART NO. 68 351 75

ITEM NO.	REFERENCE DESIGNATION	DESCRIPTION	PART NO.
137	R103	Res, 1.18M, 1%, 1/8W	17 AF 487
138	R63	Res, Ntwk, 10K, 2%, 1.75W, 16 DIP	17 AU 530
139*	R20	Res, 13.7K, 1%, 1/8W	17 AF 301
140*	R60	Res, 17.8K, 1%, 1/8W	17 AF 312
141	J13A, J13B	Contact, Male Pin, PC Mtg, .040 Dia	17 730 13
142	TP6, TP7, TP10 TP12, TP14, TP15, TP17, TP18, TP19, TP20, TP22, TP25, TP27, TP28, TP29, TP30, TP46	Socket, Lead	17 731 09
143		Not Used	
144		Not Used	
145	Q1	Transistor, A8T404A (PNP)	17 627 86
146	Q2	Transistor, 2N4124 (NPN)	17 625 58

\* PCB2 Rev. 3 and below unless Retrofit Kit P/N 68 902 70 has been installed. If kit has been installed, see items 129 (R20) and 135 (R60) for value and P/N of resistors. See also page 2 at front of this manual.

\*\* PCB2 Rev. 4 and above.

C100/200  
PARTS LIST

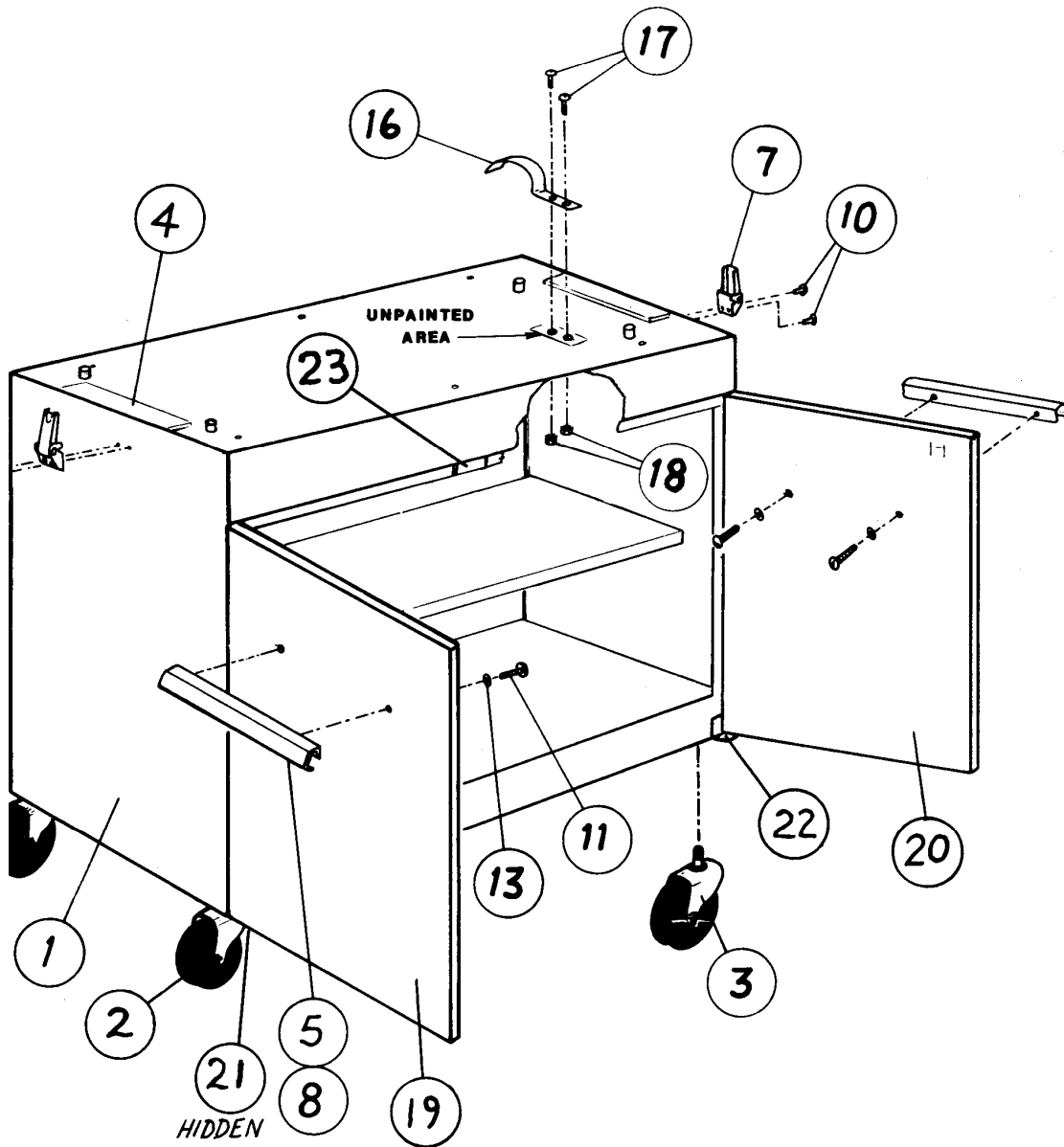

FIGURE 6.12 PARTS LOCATION DIAGRAM, CABINET STAND ASSEMBLY

**TABLE 6.12 CABINET STAND ASSEMBLY**

PART NO. 68 400 70

ITEM NO.	DESCRIPTION	PART NO.
1	Cabinet Stand	68 400 00
2	Caster	68 902 72
3	Caster With Brake	68 901 71
4	Sponge Strip, Neo.	26 800 33
5	Handle	68 400 08
6	Not Used	
7	Latch, Cabinet	24 717 00
8	Tape Met. Polyest, Blue	26 801 23
9	Not Used	
10	Scr, 6 x 1/4 B. Rd. SL SS	99 084 47
11	Scr, 8-32 x 1 TR PH SS	99 033 47
12	Not Used	
13	Wash. No. 8, LK SP S CAD	99 122 90
14	Not Used	
15	Not Used	
16	Spring, Grounding	68 400 27
17	Scr, 6-32 x 5/16 TR PH SS	99 022 98
18	Nut, 6-32 HX "KEPS" S CAD	99 105 34
19	Door, L.H.	68 400 21
20	Door, R.H.	68 400 20
21	Hinge, Door, L.H.	68 400 23
22	Hinge, Door, R.H.	68 400 22
23	Magnetic Catch	68 901 13

C100/200  
PARTS LIST

(This page is intentionally left blank.)



## **SECTION 7 DIAGRAMS**

### **7.1 GENERAL**

This section provides schematic and wiring diagrams for the Incubators.

C100/200  
DIAGRAMS

(This page is intentionally left blank.)

NOTES:  
 1. ALL RESISTOR TOL.  $\pm 1\%$ , 1/8 W UNLESS OTHERWISE SHOWN  
 2. ALL RESISTOR TOL. SHOWN 5% ( $\pm 5\%$ ) ARE 1/4 W

PT NO.	DESCRIPTION	QTY	U/M
--------	-------------	-----	-----

REVISIONS	
1. ISSUE	02/08/82
2. ECN 6803	03/08/82
3. REV STATUS OF GHS	03/08/82
4. WAS	03/08/82
5. WAS	03/08/82
6. WAS	03/08/82
7. WAS	03/08/82
8. WAS	03/08/82
9. WAS	03/08/82
10. WAS	03/08/82
11. WAS	03/08/82
12. WAS	03/08/82
13. WAS	03/08/82
14. WAS	03/08/82
15. WAS	03/08/82
16. WAS	03/08/82
17. WAS	03/08/82
18. WAS	03/08/82
19. WAS	03/08/82
20. WAS	03/08/82

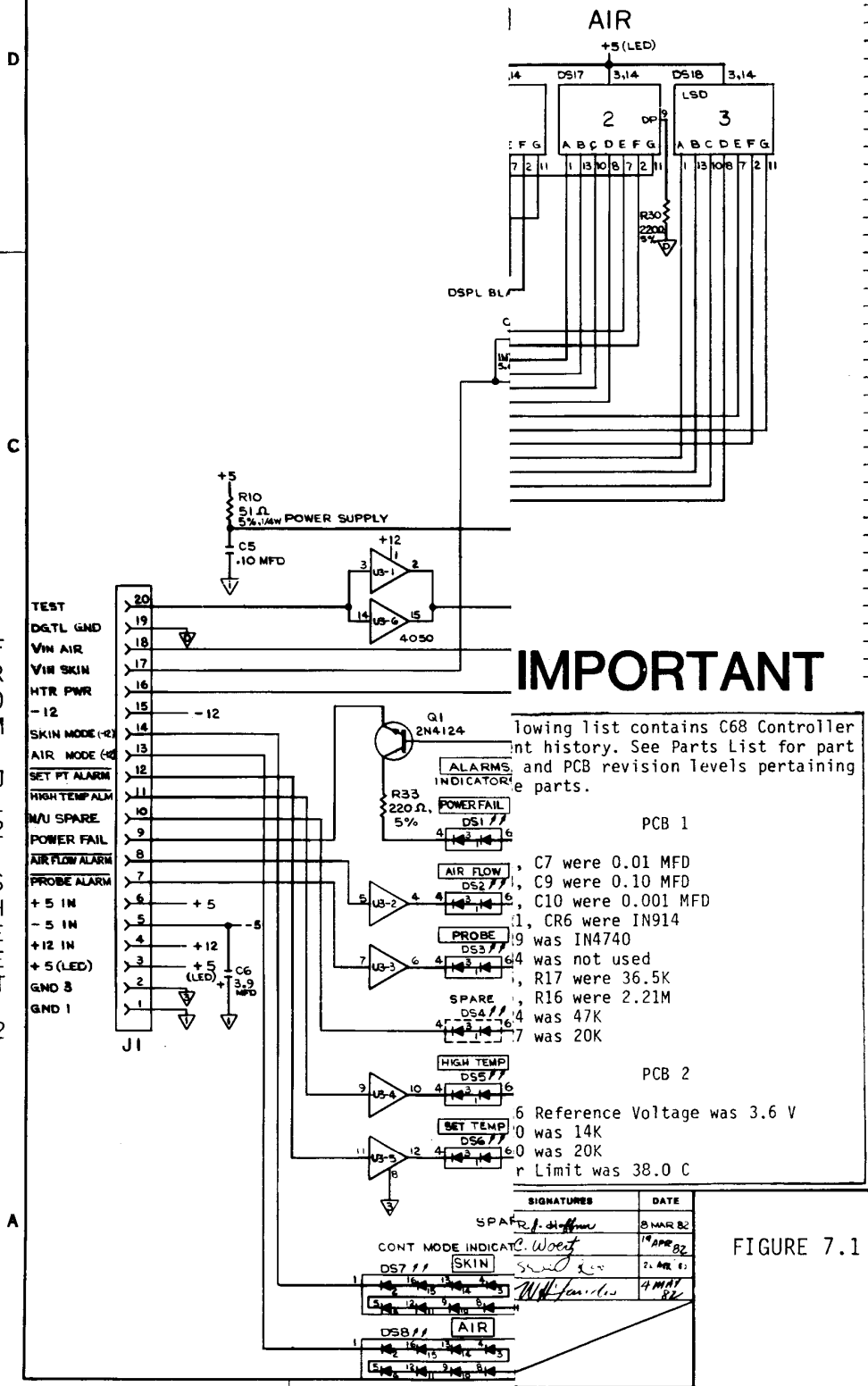

# IMPORTANT

Following list contains C68 Controller part history. See Parts List for part numbers and PCB revision levels pertaining to the parts.

PCB 1

- DS1, DS2, DS3, DS4, DS5, DS6, DS7 were 0.01 MFD
- DS8, DS9 were 0.10 MFD
- DS10, DS11 were 0.001 MFD
- CR1, CR2, CR3, CR4, CR5, CR6 were IN914
- CR7 was IN4740
- CR8 was not used
- CR9, CR10 were 36.5K
- CR11, CR12 were 2.21M
- CR13 was 47K
- CR14 was 20K

PCB 2

- CR15 Reference Voltage was 3.6 V
- CR16 was 14K
- CR17 was 20K
- CR18 Temperature Limit was 38.0 C

SIGNATURES	DATE
SPARE	03 MAR 82
CONT MODE INDICATOR	16 APR 82
DS7 // SKIN	21 APR 82
DS8 // AIR	4 MAY 82

FIGURE 7.1 C68 CONTROLLER SCHEMATIC DIAGRAM (Sheet 1 of 3)

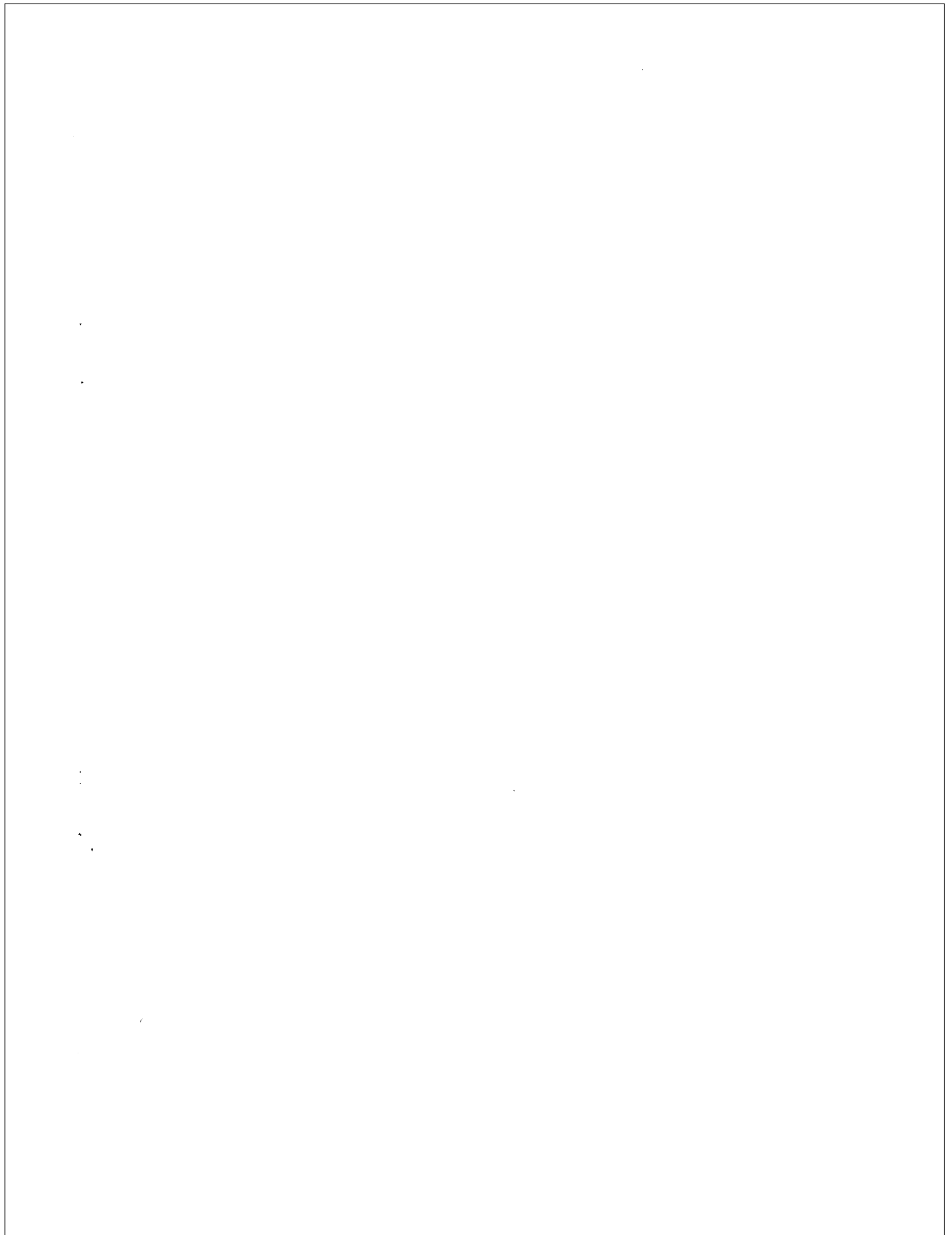

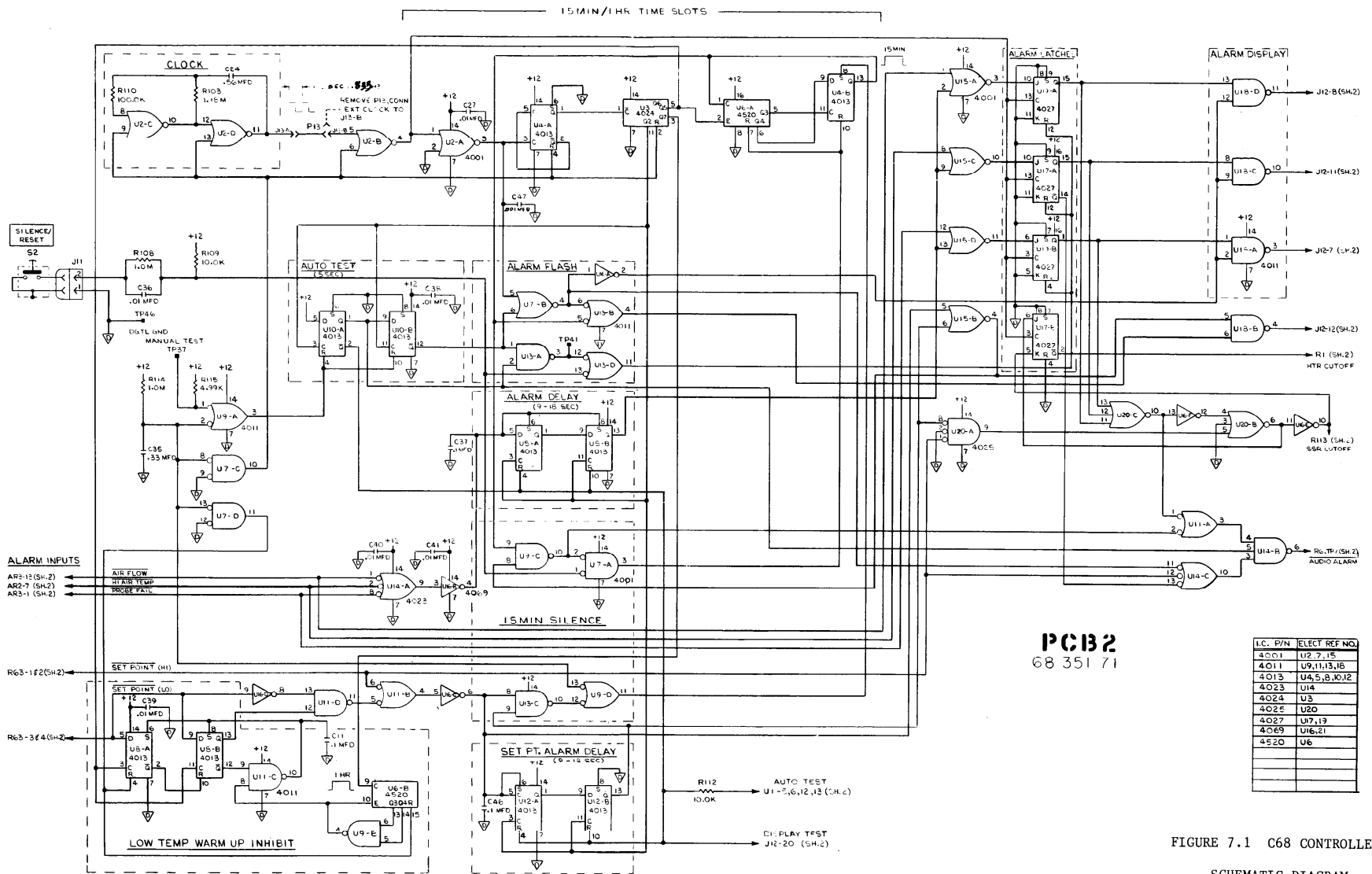

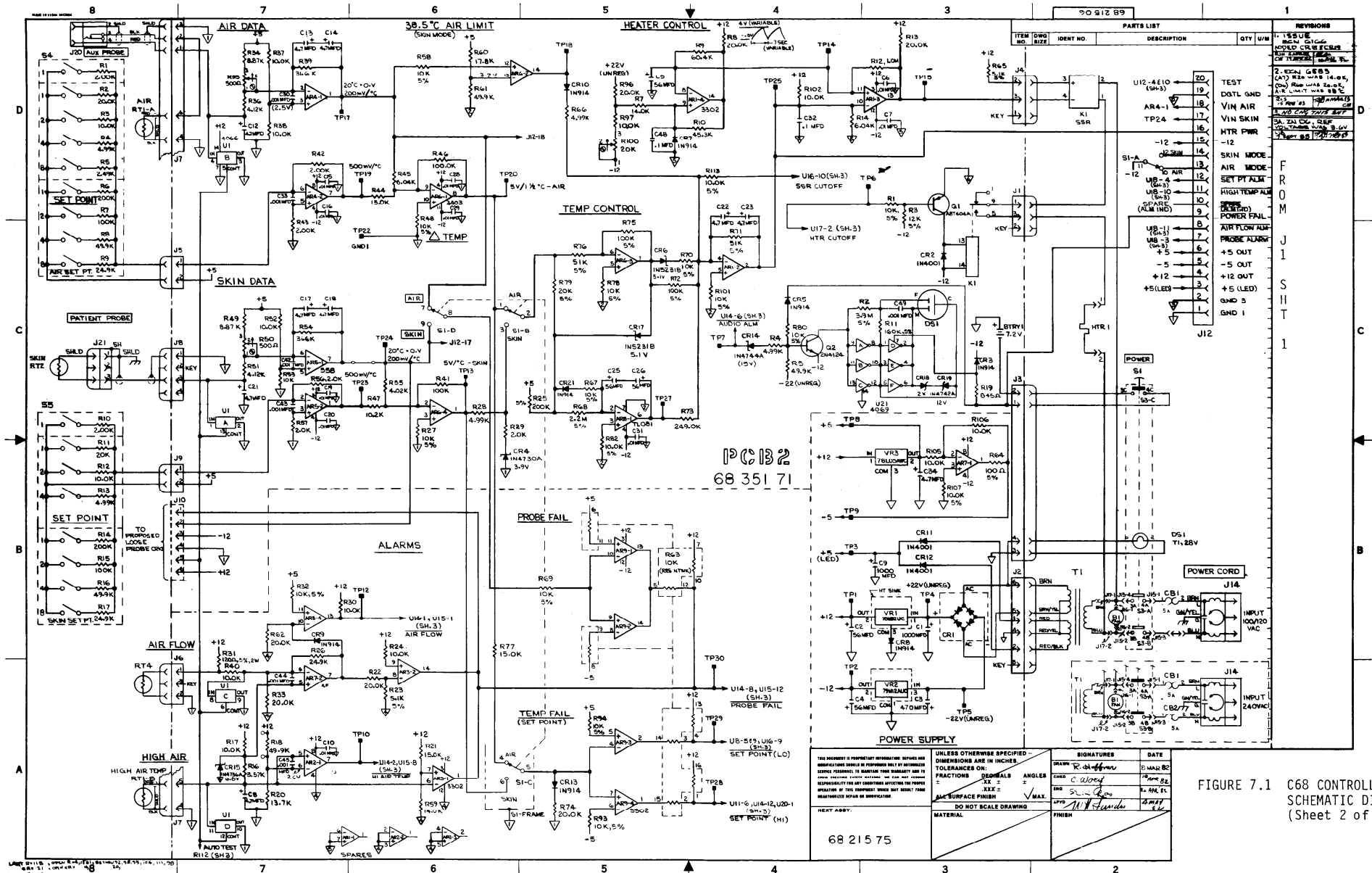

FIGURE 7.1 68 CONTROLLER SCHEMATIC DIAGRAM (Sheet 2 of 3)



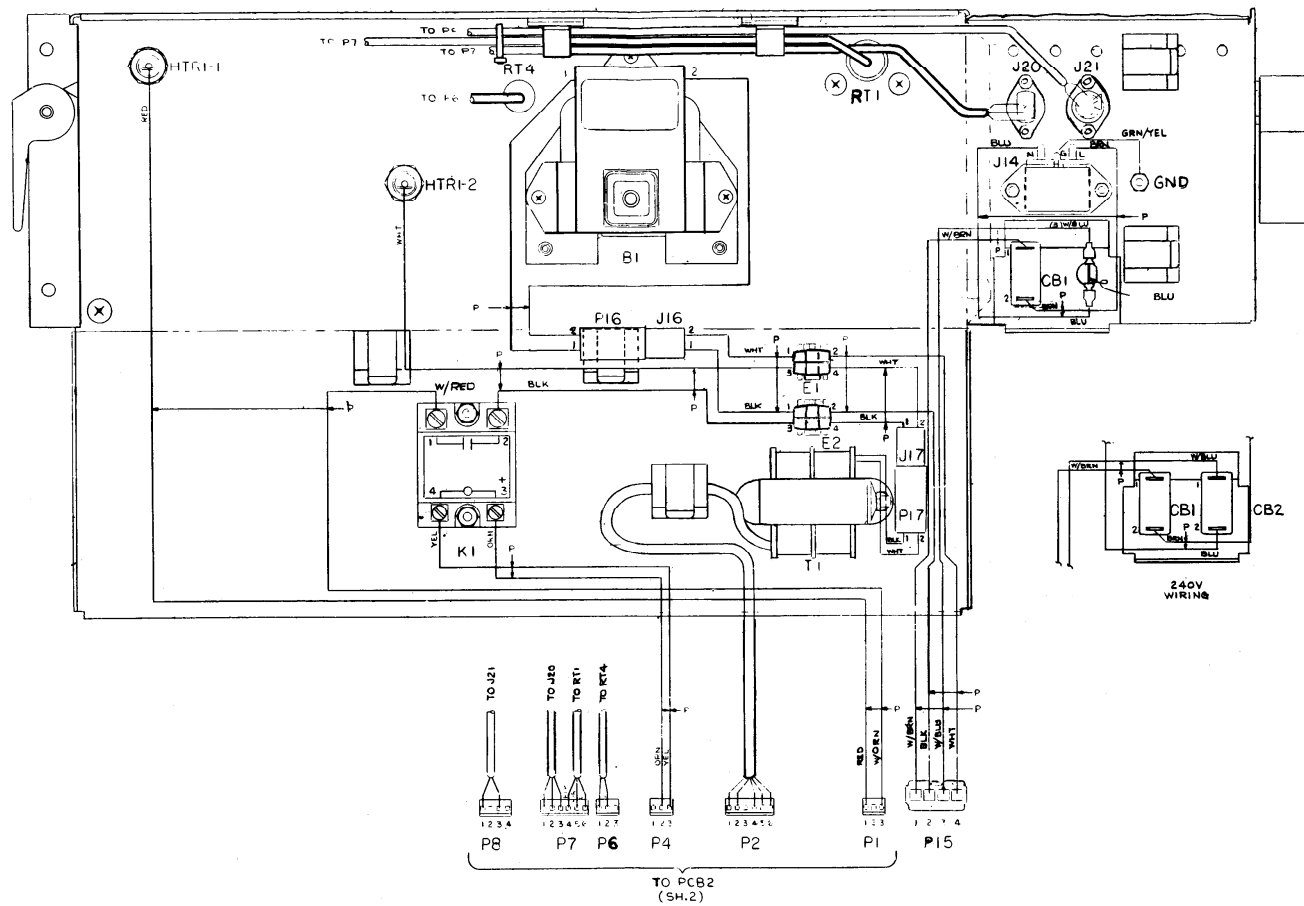
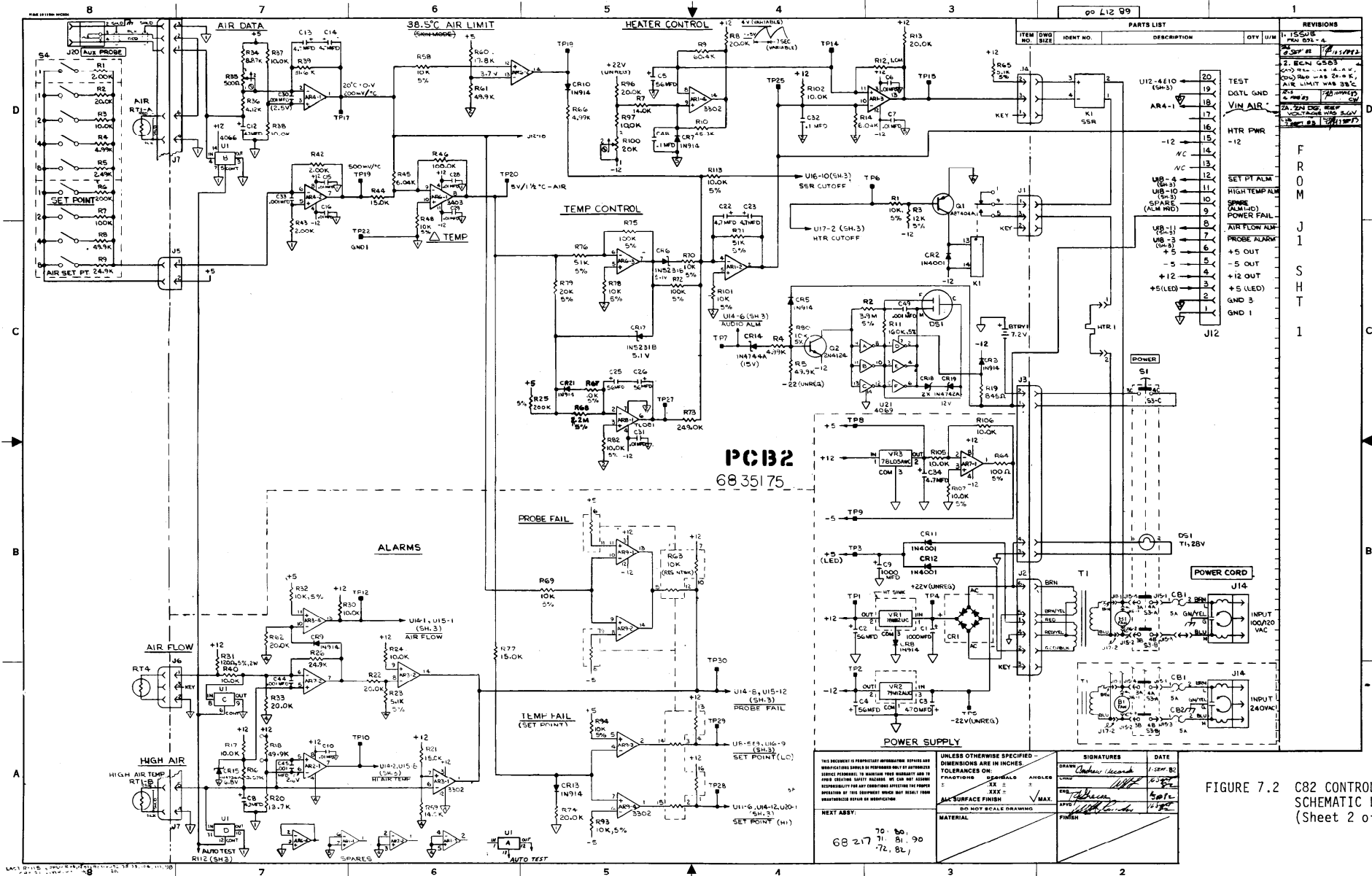

FIGURE 7.3 C68 CONTROLLER  
 WIRING DIAGRAM  
 (Sheet 1 of 2)





ITEM	QTY	UOM	REVISIONS
U12-4E10 (5W-3)	20		1. ISSUE FOR 67-4
AR4-1	19		2. ECN G5B3
	18		3. R40 WAS 20.0K
	17		AIR LIMIT WAS 38.5C
	16		4. R40 WAS 20.0K
	15		5. R40 WAS 20.0K
	14		6. R40 WAS 20.0K
	13		7. R40 WAS 20.0K
	12		8. R40 WAS 20.0K
	11		9. R40 WAS 20.0K
	10		10. R40 WAS 20.0K
	9		11. R40 WAS 20.0K
	8		12. R40 WAS 20.0K
	7		13. R40 WAS 20.0K
	6		14. R40 WAS 20.0K
	5		15. R40 WAS 20.0K
	4		16. R40 WAS 20.0K
	3		17. R40 WAS 20.0K
	2		18. R40 WAS 20.0K
	1		19. R40 WAS 20.0K

SIGNATURES	DATE
<i>Charles [Signature]</i>	1/29/82
<i>[Signature]</i>	1/29/82
<i>[Signature]</i>	1/29/82

THIS DOCUMENT IS PROPRIETARY INFORMATION AND IS NOT TO BE DISCLOSED OR REPRODUCED IN ANY MANNER WITHOUT THE WRITTEN PERMISSION OF THE COMPANY. THE COMPANY ASSUMES NO LIABILITY FOR ANY ERRORS OR OMISSIONS IN THIS DOCUMENT. THE COMPANY ASSUMES NO LIABILITY FOR ANY DAMAGE OR INJURY TO PERSONS OR PROPERTY ARISING FROM THE USE OF THIS DOCUMENT.

UNLESS OTHERWISE SPECIFIED - DIMENSIONS ARE IN INCHES	FRONT SURFACE FINISH
TOLERANCES ON: FRACTIONS DECIMALS ANGLES	DO NOT SCALE DRAWING
XX ± .015	
XX ± .005	
XX ± .002	
XX ± .001	
XX ± .0005	
XX ± .0002	
XX ± .0001	

NEXT ASSY: 70 60 90  
 72 81 81  
 72 81 81

FIGURE 7.2 C82 CONTROLLER SCHEMATIC DIAGRAM (Sheet 2 of 3)

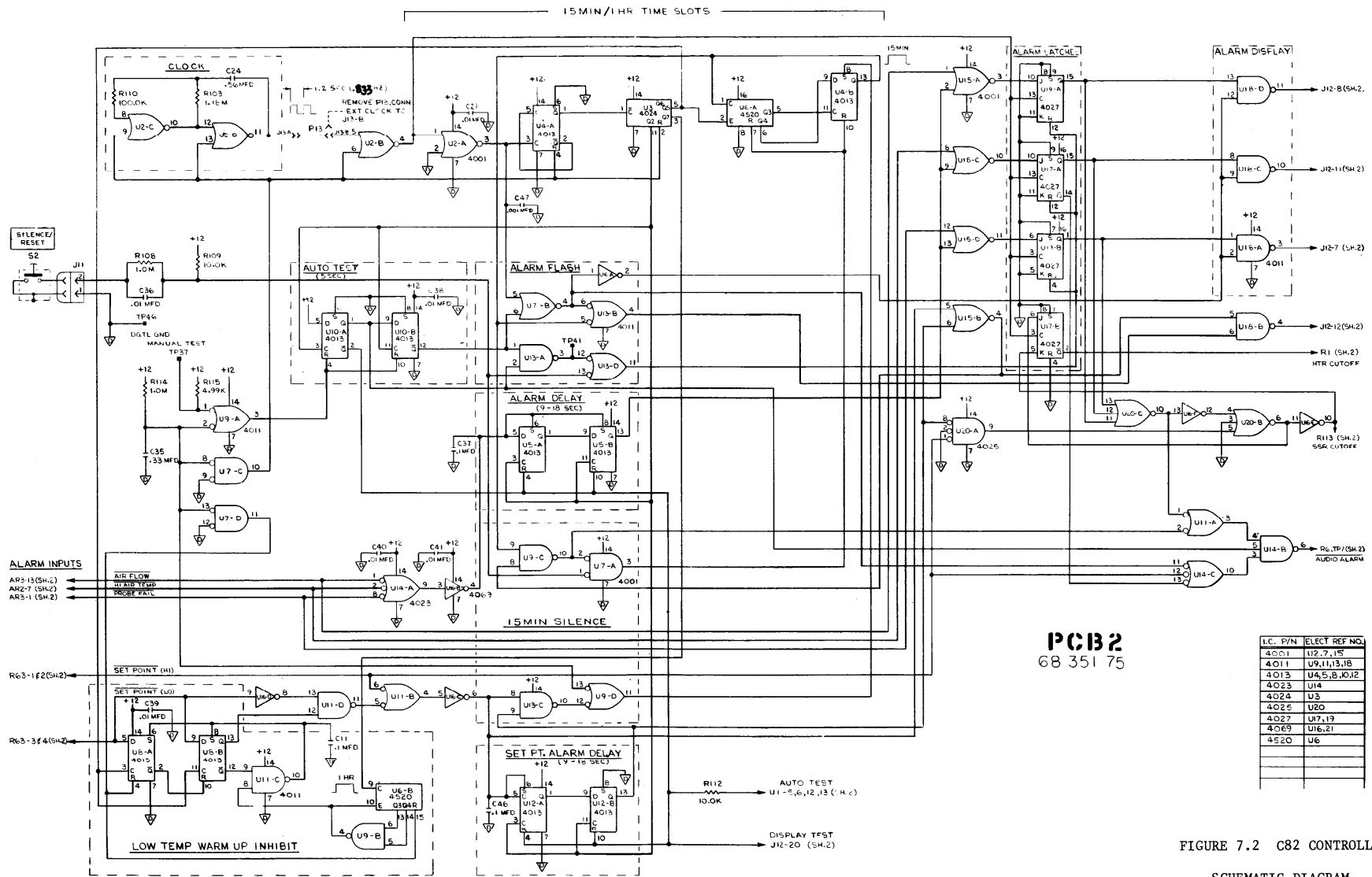

**PCB2**  
68 351 75

I.C. P/N	ELECT REF NO.
4001	U2,7,15
4011	U9,11,13,18
4013	U4,5,8,10,12
4023	U14
4024	U3
4025	U20
4027	U7,13
4069	U16,21
4520	U6

FIGURE 7.2 C82 CONTROLLER  
SCHEMATIC DIAGRAM  
(Sheet 3 of 3)

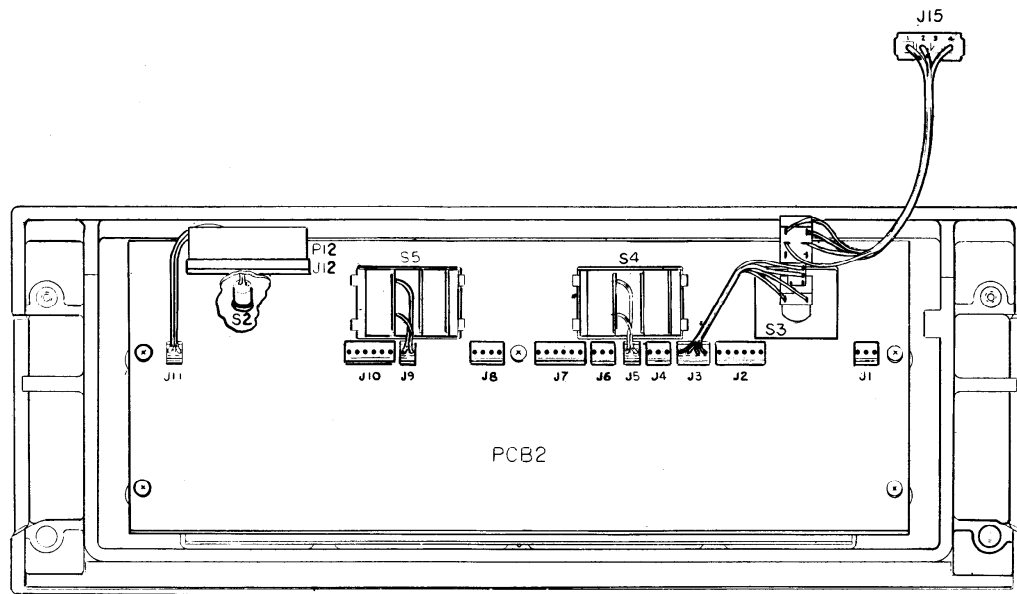

FIGURE 7.3 C68 CONTROLLER  
 WIRING DIAGRAM  
 (Sheet 2 of 2)

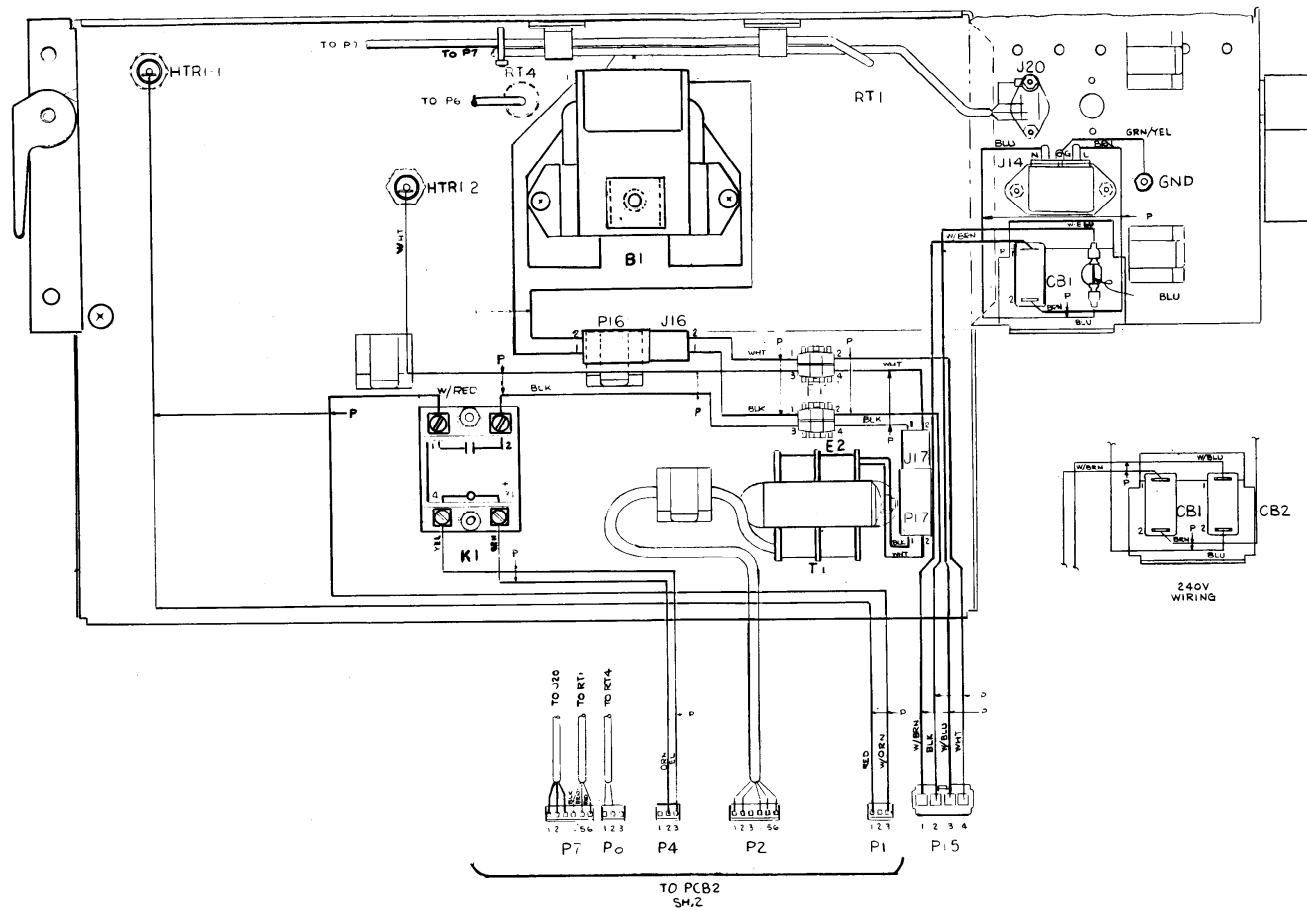

FIGURE 7.4 C82 CONTROLLER  
 WIRING DIAGRAM  
 (Sheet 1 of 2)

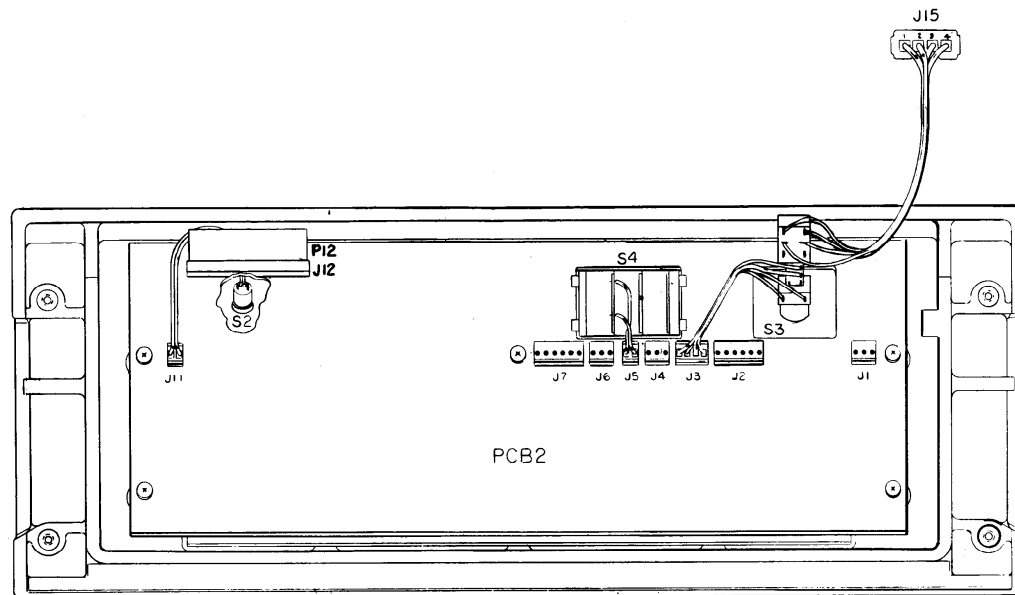

FIGURE 7.4 C82 CONTROLLER  
WIRING DIAGRAM  
(Sheet 2 of 2)