

E 13

ETTE[®] INFANT INCUBATORS S C400 QT AND C450 QT



PRELIMINARY

SERVICE MANUAL

Air-Shields  Vickers
Medical

LIMITED
WARRANTY

The product being described in this manual is warranted against defects in materials or workmanship for one year from the date of shipment from Air-Shields, Hatboro, with the following exceptions.

All consumable and disposable products are guaranteed to be free from defects upon shipment only.

Calibrations are considered normal maintenance and are not included in the 1 year warranty.*

During the warranty period any defective parts other than those listed above will be replaced at no charge to the customer. There will be no labor charge for replacing the parts within the continental U.S.

This warranty is rendered void and Air-Shields cannot be held liable for conditions resultant therefrom if:

1. Damage to the unit is incurred as a result of mishandling.
2. The customer fails to maintain the unit in a proper manner.
3. The customer uses any parts, accessories, or fittings not specified or sold by Air-Shields.
4. Sale or service is performed by a non-certified service/dealer agency.

This warranty is in lieu of all other warranties, expressed or implied, and Air-Shields shall in no event be liable for incidental or consequential damages including loss of use, property damage, or personal injury resulting from breach of warranty.

*The Accreditation Manual for Hospitals requires each piece of equipment to be tested prior to initial use and at least annually thereafter. To comply with this standard, we recommend that you participate in our Accreditation Testing Compliance Program during the warranty period. This service can be performed by certified technicians through our Product Service Group and authorized dealers.

SERVICE

For optimal performance, product service should be performed only by qualified service personnel. Product Service Group instrumentation specialists are located throughout the United States and are dispatched for required maintenance by calling 800-523-2404. Customers outside the U.S. should contact their local factory-authorized Air-Shields' distributor for service.

Air-Shields  **Vickers
Medical**
330 Jacksonville Road, Hatboro, PA 19040

CAT. NO. 68 994 50-A
E 1 2 3 4 5 6 7 8 9
A 1 2 3 4 5 6 7 8 9

Printed in USA 10/94

PLEASE READ

Please check the A page for change information.

Since Air-Shields conducts a continuous product improvement program, circuit and component improvements are sometimes incorporated into equipment before they can be incorporated into the printed manuals. When this occurs, changed material is provided on separate sheets at the rear of the manual or under separate cover in the form of a change package. Changed material on each page of text is indicated by a vertical bar in the margin next to the changed material, as shown on the right.

THIS MANUAL CONTAINS PROPRIETARY INFORMATION. REPAIRS AND AUTHORIZED MODIFICATIONS SHOULD BE PERFORMED ONLY BY QUALIFIED SERVICE PERSONNEL TO MAINTAIN YOUR WARRANTY AND TO AVOID CREATING SAFETY HAZARDS. WE CANNOT ASSUME RESPONSIBILITY FOR ANY CONDITIONS AFFECTING THE PROPER OPERATION OF THIS EQUIPMENT WHICH MAY RESULT FROM UNAUTHORIZED REPAIR OR MODIFICATION.

NOTE ON REPLACEMENT PARTS

Some parts used in your equipment may be different than those which appear in the Parts List of this manual. This sometimes occurs due to difficulty in parts procurement, but does not alter the function of the equipment. Order the part listed in the Parts List.

NOTE: ALSO SEE PAGE 2.

LIST OF EFFECTIVE PAGES

THERE ARE NO MODIFICATIONS AVAILABLE.

<u>PAGE NO.</u>	<u>CHANGE NO.</u>	<u>DATE OF ISSUE</u>
Front Cover	0	10/94
Inside Front Cover	0	10/94
1	0	10/94
2	0	10/94
A and B	0	10/94
i through	0	10/94
1-1	0	10/94
2-1 through	0	10/94
3-1 through	0	10/94
4-1 through	0	10/94
5-1 through	0	10/94
6-1 through	0	10/94
7-1 through	0	10/94

TABLE OF DEFINITIONS AND SYMBOLS

TECHNICAL DEFINITIONS

Control Zone. A plane 10 cm above the mattress with an area defined by the center of four quadrants formed by lines that divide the width and length of the mattress surface.

Incubator Temperature. Air temperature at a point 10 cm (4 in.) above and centered over the mattress surface.

Steady Temperature Condition. The condition reached when the average **Incubator Temperature** does not vary more than 0.2 °C over a period of one hour.

Temperature Overshoot. The amount by which **Incubator Temperature** exceeds average **Incubator Temperature** during **Steady Temperature Condition**, resulting from a change in temperature.

Temperature Rise Time. The time required for the **Incubator Temperature** to rise 11 °C.

Temperature Uniformity. The amount by which the average temperature at each of four points 10 cm (4 in.) above the mattress surface differs from the average **Incubator Temperature at Steady Temperature Condition**. The four points are the centers of four quadrants formed by lines that divide the width and length of the mattress surface.

Temperature Variation. The difference between the **Incubator Temperature** and the **Average Incubator Temperature** during **Steady Temperature Condition**.

(This page is intentionally left blank.)

ISOLETTE® Infant Incubator

NOTE, IMPORTANT, CAUTION, AND WARNING

















NOTE: A Note is inserted in text to point out procedures or conditions which may otherwise be misinterpreted or overlooked. A Note may also be used to clarify apparently contradictory or confusing situations.

IMPORTANT: Similar to a Note but used where greater emphasis is required.

CAUTION: A Caution is inserted in text to call attention to a procedure which, if not followed exactly, can lead to damage or destruction of the equipment or improper operation.

WARNING: A Warning is inserted in text to call attention to dangerous or hazardous conditions inherent to the operation, cleaning, and maintenance of the equipment which may result in personal injury or death of the operator or patient.

SYMBOLS

	Attention; consult accompanying documents.		Set Temperature Up Key
	Type B equipment with an F-type isolated (floating) applied part.		Set Temperature Down Key
	Caution: Electric shock hazard. Refer service to qualified personnel.		Keypad Lock Indicator
	AC power.		Keypad Lock Key
	Protective Earth (ground).		Temperature Override Mode Indicator
	Air Mode Control Indicator		Temperature Override Mode Selection Key
	Baby Mode Control Indicator		Silence/Reset Key
	Air Mode Control Selection Key		POWER On/Off Switch
	Baby Mode Control Selection Key		

LIST OF FIGURES

FIGURE	PAGE
1.1 ACCESSORIES	1-2
2.1 ASSEMBLY, INCUBATOR MOUNTED ON STANDARD CABINET STAND	2-2
2.2 ASSEMBLY, INCUBATOR MOUNTED ON VHA CABINET STAND	2-4
2.3 MATTRESS REMOVED FROM THE INCUBATOR	2-5
2.4 WEIGHING PLATFORM INSTALLED IN MATTRESS TRAY	2-5
2.5 MATTRESS TRAY AND MATTRESS ON WEIGHING PLATFORM	2-6
2.6 HOOD RELEASE OPERATION	2-7
2.7 ACCESS PANEL OPERATION	2-8
2.8 CHECK THE IRIS ENTRY PORTS	2-8
2.9 ACCESS DOOR OPERATION	2-9
2.10 MATTRESS TILT HANDLES	2-10
2.11 MATTRESS TRAY OPERATION	2-10
2.12 FILTER COVER REMOVAL	2-10
3.1 AIR/O ₂ CIRCULATION SYSTEM GROUP 1	3-5
3.2 AIR/O ₂ CIRCULATION SYSTEM GROUP 2	3-6
3.3 CONTROLLER FUNCTIONAL BLOCK DIAGRAM	3-7
4.1 REMOVAL OF CONTROLLER	4-1
4.2 REMOVING THE MATTRESS TILT MECHANISM	4-2
4.3 REMOVAL OF INNER WALL, GROUP 1	4-3
4.4 REMOVAL OF INNER WALL, GROUP 2	4-4
4.5 REMOVAL OF MAIN DECK, GROUP 1	4-5
4.6 REMOVAL OF MAIN DECK, GROUP 2	4-5
4.7 REMOVAL OF DECK PLATE, GROUP 2	4-6
4.8 REMOVAL OF AIR INTAKE TUBE	4-6
4.9 REMOVAL OF HUMIDITY FILL PIPE ASSEMBLY	4-7
4.10 INSTALLATION OF MAIN DECK AND HOOD SEAT GASKET, GROUP 1	4-9
4.11 INSTALLATION OF DECK PLATE AND MAIN DECK	4-9
4.12 INSTALLATION OF IRIS ENTRY PORT SLEEVE	4-10
4.13 INSTALLATION OF ACCESS DOOR GASKET	4-11
5.1 POWER SUPPLY LOCATION OF TEST POINTS AND ADJUSTMENTS	5-7
5.2 MAIN BOARD LOCATION OF TEST POINTS AND ADJUSTMENTS	5-8
5.3 OXYGEN INPUT VALVE ASSEMBLY	5-18
5.4 VHA STAND WIRING DIAGRAM-120V UNITS	5-18
5.5 VHA STAND WIRING DIAGRAM-220/240V UNITS	5-19
5.6 INSERTION OF GIB PINS	5-22
6.1 PARTS LOCATION DIAGRAM, HOOD ASSEMBLY, GROUP 2 UNITS	6-4
6.2 PARTS LOCATION DIAGRAM, ACCESS PANEL ASSEMBLY, GROUP 2 UNITS	6-8
6.3 PARTS LOCATION DIAGRAM, SHELL AND DECK ASSEMBLY, GROUP 2 UNITS	6-10

LIST OF FIGURES (cont.)

FIGURE	PAGE
6.4 PARTS LOCATION DIAGRAM, HOOD ASSY, GROUP 1	6-14
6.5 PARTS LOCATION DIAGRAM, ACCESS PANEL ASSEMBLY, GROUP 1	6-16
6.6 PARTS LOCATION DIAGRAM, SHELL AND DECK ASSEMBLY, GROUP 1	6-18
6.7 PARTS LOCATION DIAGRAM, MANUAL TILT DECK ASSEMBLY, GROUP 1	6-22
6.8 PARTS LOCATION DIAGRAM, CONTROLLER ASSEMBLY, GROUP 1	6-24
6.9 PARTS LOCATION DIAGRAM, CONTROLLER ASSY, GROUP 2	6-30
6.10 PARTS LOCATION DIAGRAM, MAIN/DISPLAY BOARD	6-36
6.11 PARTS LOCATION DIAGRAM, PROBE BOARD	6-40
6.12 PARTS LOCATION DIAGRAM, POWER SUPPLY BOARD, GROUP 1	6-42
6.13 PARTS LOCATION DIAGRAM, POWER SUPPLY BOARD, GROUP 2	6-46
6.14 PARTS LOCATION DIAGRAM, CABINET STAND ASSEMBLY	6-50
6.15 PARTS LOCATION DIAGRAM, VHA STAND ASSEMBLY	6-52
6.16 PARTS LOCATION DIAGRAM, INNER COLUMN ASSEMBLY	6-58
6-17 PARTS LOCATION DIAGRAM, CABINET, VHA STAND	6-60

LIST OF TABLES

TABLE	PAGE
1.1 SERIES CHANGE-HOOD/SHELL ASSEMBLY, MODELS - C400H-1, 1E, 2, 2E, 3,, 3E, 4, AND 4E; MODELS - C450H-1, 1E, 2, 2E, 3, 3E, 4, AND 4E	1-5
1.2 SERIES CHANGE - CONTROLLER ASSEMBLY, MODELS - C400C-1, 1E, 2, AND 2E	1-5
1.3 SERIES CHANGE - CONTROLLER ASSEMBLY, MODELS - C450C-1, 1E, 2, AND 2E	1-5
3.1 SPECIFICATIONS	3-1
6.1 HOOD ASSEMBLY, GROUP 2 UNITS, PARTS LIST	6-5
6.1 HOOD ASSEMBLY, GROUP 2 UNITS, PARTS LIST	6-6
6.2 ACCESS PANEL ASSEMBLY, GROUP 2 UNITS, PARTS LIST	6-9
6.3 SHELL AND DECK ASSEMBLY, GROUP 2 UNITS, PARTS LIST	6-11
6.4 HOOD ASSEMBLY, GROUP 1, PARTS LIST	6-15
6.5 ACCESS PANEL ASSEMBLY, GROUP 1, PARTS LIST	6-17
6.6 SHELL AND DECK ASSEMBLY, GROUP 1, PARTS LIST	6-19
6.7 MANUAL TILT DECK ASSEMBLY, GROUP 1, PARTS LIST	6-23
6.8 CONTROLLER ASSEMBLY, PARTS LIST	6-27
6.9 CONTROLLER ASSEMBLY, GROUP 2, PARTS LIST	6-33
6.10 MAIN/DISPLAY BOARD, PARTS LIST	6-37
6.10 MAIN/DISPLAY BOARD, PARTS LIST	6-38
6.10 MAIN/DISPLAY BOARD, PARTS LIST	6-39
6.11 PROBE BOARD, PARTS LIST	6-41

LIST OF TABLES

TABLE	PAGE
6.12 POWER SUPPLY BOARD GROUP 1, PARTS LIST	6-43
6.12 POWER SUPPLY BOARD GROUP 1, PARTS LIST	6-44
6.13 POWER SUPPLY BOARD GROUP 2, PARTS LIST	6-47
6.13 POWER SUPPLY BOARD GROUP 2, PARTS LIST	6-48
6.14 CABINET STAND, ASSEMBLY, PARTS LIST	6-51
6.15 VHA STAND ASSEMBLY, PARTS LIST	6-54
6.16 INNER COLUMN ASSEMBLY, PARTS LIST	6-59
6.17 CABINET, VHA STAND, PARTS LIST	6-61

LIST OF FLOWCHARTS

FLOWCHART	PAGE
5.1 SYSTEM FAIL ALARM TROUBLESHOOTING (Sheet 1 of 2)	5-10
5.1 SYSTEM FAIL ALARM TROUBLESHOOTING (Sheet 2 of 2)	5-11
5.2 POWER SUPPLY BOARD TROUBLESHOOTING (Sheet 1 of)	5-12
5.2 POWER SUPPLY BOARD TROUBLESHOOTING (Sheet 2 of)	5-13
5.2 POWER SUPPLY BOARD TROUBLESHOOTING (Sheet 3 of)	
5.3 MAIN BOARD TROUBLESHOOTING (Sheet 1 of)	5-14
5.3 MAIN BOARD TROUBLESHOOTING (Sheet 2 of)	5-15
5.3 MAIN BOARD TROUBLESHOOTING (Sheet 3 of)	5-16

SECTION 1 GENERAL INFORMATION

1.1 INTRODUCTION

This manual provides instructions for installation, maintenance and repair of the Isolette® Infant Incubators, Models C400 QT® and C450 QT®.

This manual is intended for use only by trained, qualified service personnel. Instructions for the operator of the equipment are provided in a separate operator's manual.

1.2 DESCRIPTION

The forced air circulation system of the Incubator permits stable temperature control, uniform heat distribution, humidification, effective isolation of the infant from airborne contaminants, and control of oxygen concentrations. Accessibility to the infant is provided by an Access Panel, Access Doors, and Iris Entry Ports. When the Access Panel is open, a curtain of warm air flows from beneath the front edge of the mattress toward the top of the Access Panel opening; this air curtain minimizes the temperature drop within the hood environment. The Incubator is designed for use in a nursery environment having a typical ambient operating temperature range of 20 to 30 °C. A guard rail is standard on all units. On the Model C450 QT®, Baby or Air Temperature Control is selected by a front panel control. The Model C400 QT® is equipped only for air temperature control. Instrumentation includes digital display for temperature, relative indication of heater output, and a comprehensive visual and audible alarm system which includes an alarm test feature. The Models C400 QT® and C450 QT® Incubators also include the following features:

- Oval Access Doors with a Quiet Latch
- The Mattress Tilt Mechanism continuously variable from 0° to 9° from either end
- Optional VHA Stand

1.3 ACCESSORIES

Accessories available for use with the Incubators are illustrated in Figure 1.1. Refer to Section 6 of this manual for part numbers.

- Cabinet Stand
- Guard Rail
- Rail System Standard Cabinet Stand
- VHA (Vertical Height Adjustable Stand)
- Rail System for VHA Stand
- SOLAIR™ Transparent Hood Warmer (Not Shown)
- MICRO-LITE™ Phototherapy System
- DEW-ETTE® 2 Incubator Humidifier
- Remote Alarm Module
- WARM WEIGH® Infant Scale, Model I20 (Refer to Figure 2.5)
- Monitor Shelf Package
- ATHENA® Shelf Assembly
- ATHENA® PAM Mounting Kit (Not Shown)
- Utility Pole Assembly
- I.V. Tree Assembly
- Oxygen Flowmeter Kit (Not Shown)
- Air Flow Kit (Not Shown)
- Suction Kit (Not Shown)
- Blender Kit (Not Shown)

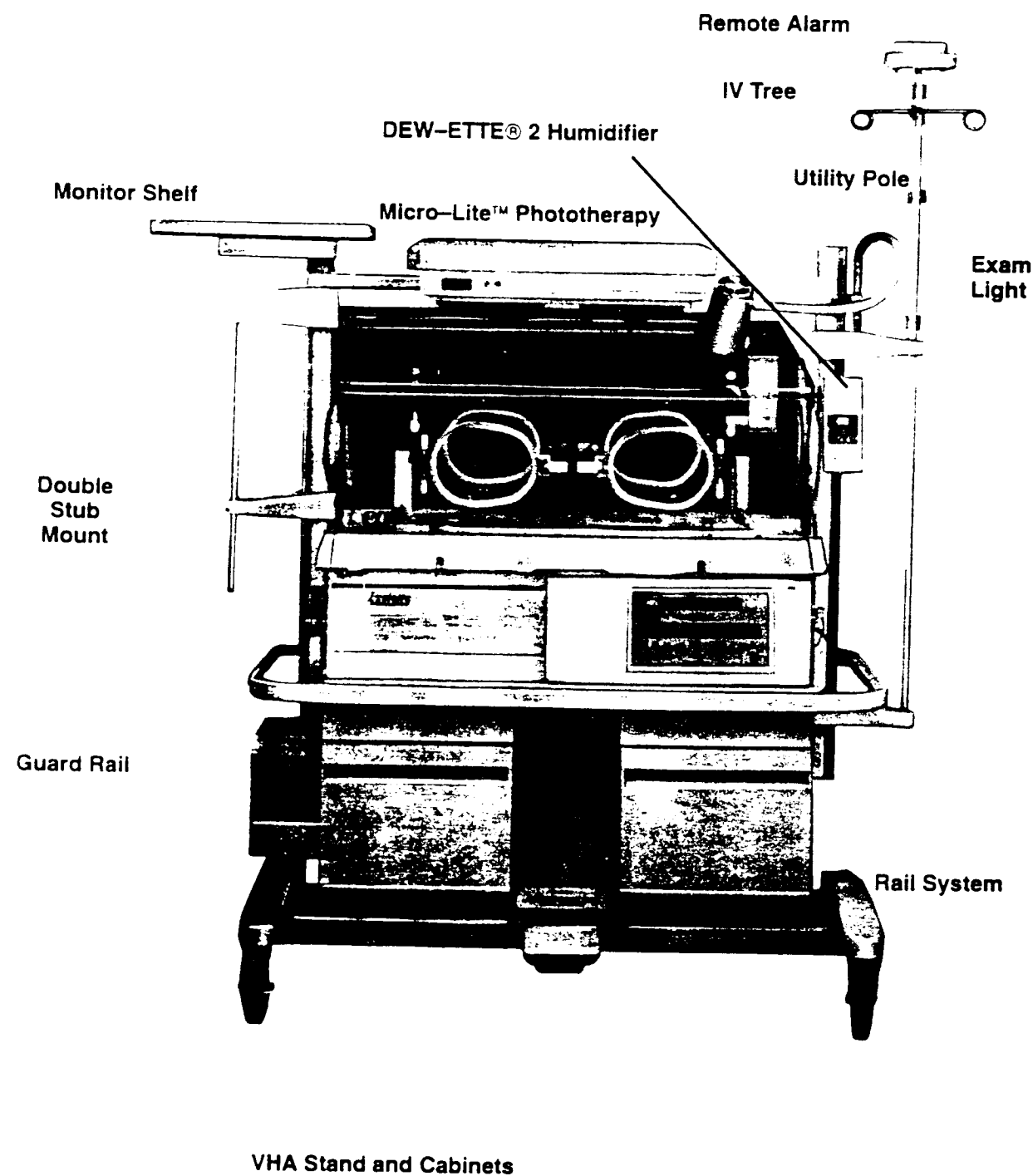

FIGURE 1.1 ACCESSORIES

1.4 MODEL IDENTIFICATION SERIES CHANGE

The Isolette® Infant Incubators, Models C400 QT® and C450 QT®, have two Data Tags which list model identification and series number. The locations of the data tags are as follows:

CONTROLLER: Located on the inside top panel.

HOOD/SHELL ASSEMBLY: Located on the right side panel of the Shell.

The following example explains the content of the data tag:

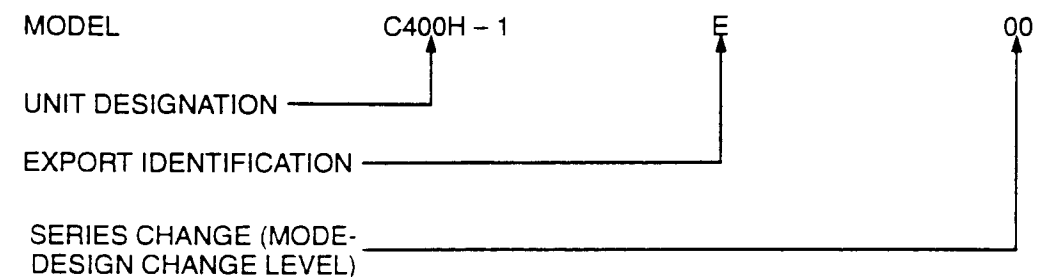

The Isolette® Infant Incubators, Models C400 QT® and C450 QT®, have two different Hood/Shell and Controller Assemblies.

GROUP NUMBER 1

The Data Tag on the Hood/Shell of Group 1 carries the Model No. C400H-1 (1E) or C450H-1 (1E) and can be identified by the following characteristics:

The Hood has two Tubing Access Grommets, one located on either side (Refer to Figure 6.4).

The Access Panel has an inner wall (refer to Figure 6.5)

The Main Deck is held in place by a Retainer Knob (Refer to Figure 4.5)

The Data Tag on the Controller of Group 1 carries the Model No. C400C-1 (1E) or C450C-1 (1E) and can be identified by the following characteristics:

The Controller is equipped with an ac motor.

The Controller does not have a keying pin located between the Impeller and Heater Coil.

GROUP NUMBER 2

The Data Tag on the Hood/Shell of Group 2 carries the Model No. C400H-2, 3 or 4 (2E, 3E or 4E) or C450H-2, 3, or 4 (2E, 3E or 4E) and can be identified by the following characteristics:

The Hood has four Tubing Access Grommets, two located on either side (Refer to Figure 6.1).

The Access Panel does not have an Inner Wall.

The Main Deck consists of the Deck Plate and Main Deck (refer to Figures 4.6 and 4.7).

The Controller is equipped with a round dc motor.

The Controller has a keying pin located between the Impeller and Heater Coil.

TABLE 1.1 SERIES CHANGE – HOOD/SHELL ASSEMBLY, MODELS – C400H-1, 1E, 2, 2E, 3, 3E, 4, AND 4E. MODELS – C450H-1, 1E, 2, 2E, 3, 3E, 4, AND 4E

SERIES NO.	DESCRIPTION	ITEMS/ASSEMBLIES AFFECTED
00	Original Design	None

TABLE 1.2 SERIES CHANGE—CONTROLLER ASSEMBLY, MODELS – C400C-1, 1E, 2, AND 2E

SERIES NO.	DESCRIPTION	ITEMS/ASSEMBLIES AFFECTED
00	Original Design	None

TABLE 1.3 SERIES CHANGE—CONTROLLER ASSEMBLY, MODELS – C450C-1, 1E, 2 AND 2E

SERIES NO.	DESCRIPTION	ITEMS/ASSEMBLIES AFFECTED
00	Original Design	None

SECTION 2 INSTALLTION

2.1 UNPACKING

Typically, the Cabinet Stand, the Hood/Base Assembly, Filter/Filter Cover Assembly and the Guard Rail are shipped in separate cartons. When removing the equipment from the cartons, take care not to scratch or otherwise damage unprotected surfaces. Remove all packing materials from the Shell Assembly.

2.2 ASSEMBLY – INCUBATORS EQUIPPED WITH STANDARD CABINET STAND

CAUTION: Two people are required to assemble the Hood/Base Assembly and the Cabinet Stand.

Instructions for assembling the Incubator are provided below:

A. REMOVE THE CONTROLLER FROM THE INCUBATOR. Attach the Guard Rail to the underside of the Base Assembly using the 6 No. 10 – 32 x 1/2" Screws and Keps nuts supplied (see Figure 2.1). Replace the Controller.

B. PLACE THE GUARD RAIL AND BASE ASSEMBLY ON THE CABINET STAND as shown in Figure 2.1.

WARNING: The Incubator must be attached to the Cabinet Stand using the clamps provided. Failure to do so could result in the Incubator separating from the stand if sufficiently tilted, particularly with the hood open.

C. SECURE THE HOOD/BASE ASSEMBLY TO THE CABINET STAND using the clamp on each side of the Cabinet Stand. Adjust threaded clamp on stand for positive latching. Locking bar should be approximately horizontal when clamp is engaged in retainer. Lock clamp by rotating locking bar to vertical position (see Figure 2.1).

IMPORTANT: This Incubator has been shipped without a Filter and Filter Cover Assembly. The Filter Cover Assembly has been shipped in a separate carton. **DO NOT** place Incubator into use until properly installed.

D. INSTALL THE AIR FILTER AND FILTER COVER ON THE REAR OF THE UNIT (see Figure 4.8). If the Unit is to be equipped with a Dew-ette® 2 Humidifier, Model DH90-2, refer to the Operator's Manual for the Dew-ette® 2 Incubator Humidifier and install the Air Intake Valve Assembly, Special Air Filter and Humidifier Filter Cover.

E. CONNECT THE POWER CORD TO THE INCUBATOR.

- Screw, 10 – 32 x 1/2" (6) 99 042 01
Nut, Keps, 10 – 32 (6) 99 107 36

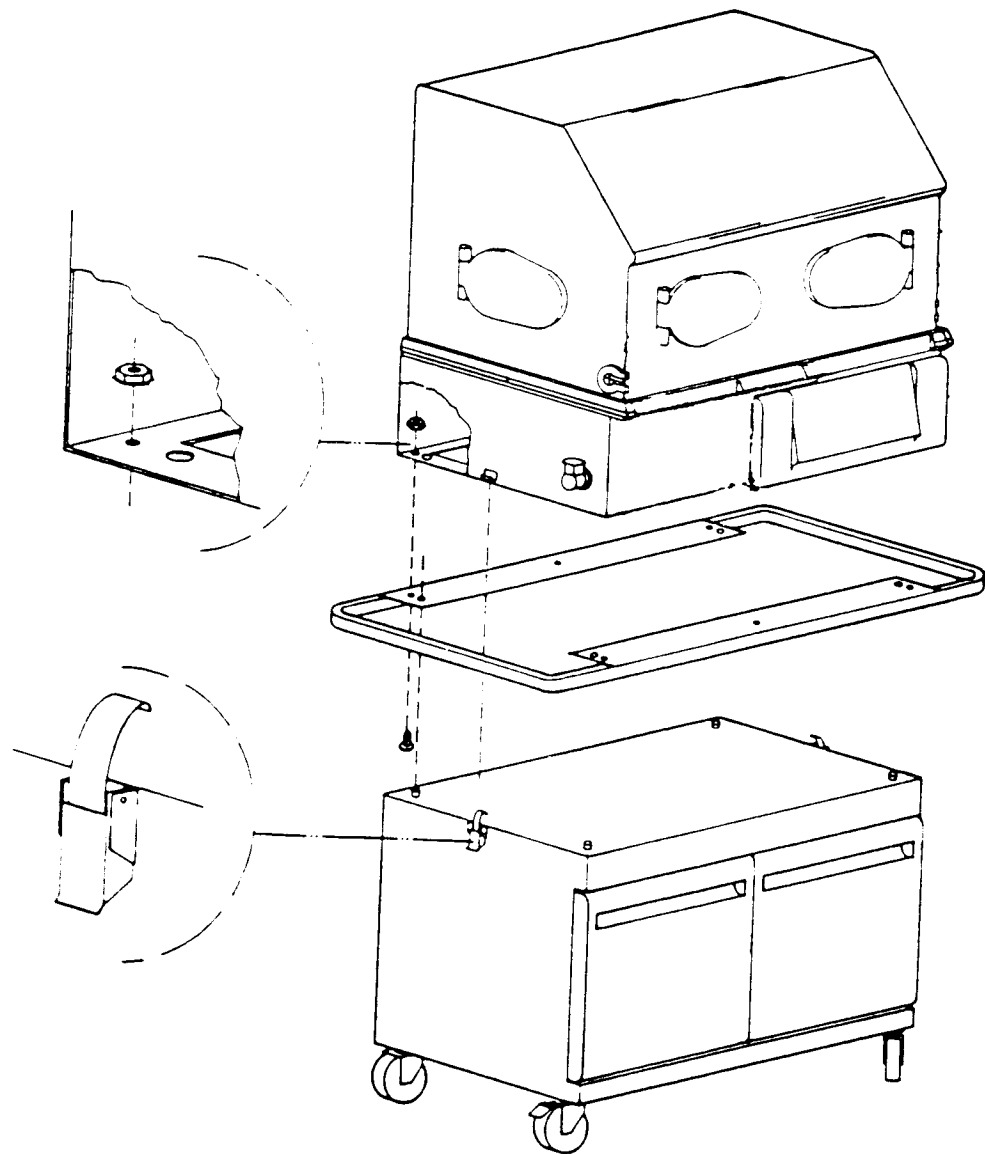

FIGURE 2.1 ASSEMBLY, INCUBATOR MOUNTED ON STANDARD CABINET STAND

2.2 ASSEMBLY – INCUBATORS EQUIPPED WITH VERTICAL HEIGHT ADJUSTABLE STAND

CAUTION: Heavy Equipment – To prevent injury or damage to the Incubator/Stand, two persons of sufficient strength are required to adequately control the Incubator when transporting it.

CAUTION: Always lower the Incubator to its lowest position prior to transport for optimum stability.

- A. REMOVE THE CONTROLLER FROM THE INCUBATOR.** Attach the Guard Rail to the underside of the Base Assembly using the 6 bolts and Keps nuts supplied (see Figure 2.2.).
- B. PLACE THE GUARD RAIL AND BASE ASSEMBLY ON THE VHA (VERTICAL HEIGHT ADJUSTABLE) STAND** as shown in Figure 2.2.

WARNING: The Incubator must be attached securely to the VHA Stand using the clamps provided. Failure to do so could result in the Incubator separating from the stand if sufficiently tilted, particularly with the hood open.

- C. SECURE THE BASE ASSEMBLY TO THE VHA STAND** using the clamp on each side of the VHA Stand.

WARNING: The VHA Stand is intended for use with Air-Shields' Incubators which use the C400/C450 Incubator Base Assembly. **DO NOT USE** the VHA Stand with other Incubators. Incubator instability or tip-over could result.

IMPORTANT: Check to be certain Incubator is firmly secured to the stand at both ends. Do not place in service if not firmly secured.

IMPORTANT: This Incubator has been shipped without a Filter and Filter Cover Assembly. The Filter Cover Assembly has been shipped in a separate carton. **DO NOT** place Incubator into use until properly installed.

- D. INSTALL THE AIR FILTER AND FILTER COVER ON THE REAR OF THE UNIT** (see Figure 4.8). If the Unit is to be equipped with a Dew-ette® 2 Incubator Humidifier, Model DH90-2, refer to the Operator's Manual for the Dew-ette® 2 Incubator Humidifier and install the Air Intake Valve Assembly, Special Air Filter and Humidifier Filter Cover.
- E. CONNECT THE VHA POWER CORD TO THE WALL RECEPTACLE** and the interconnecting power cord on the VHA Stand to the Incubator power cord receptacle.

- Screw, 10 -32 x 1/2" (6) 99 042 01
- Nut, Keps 10 -32 (6) 99 107 36

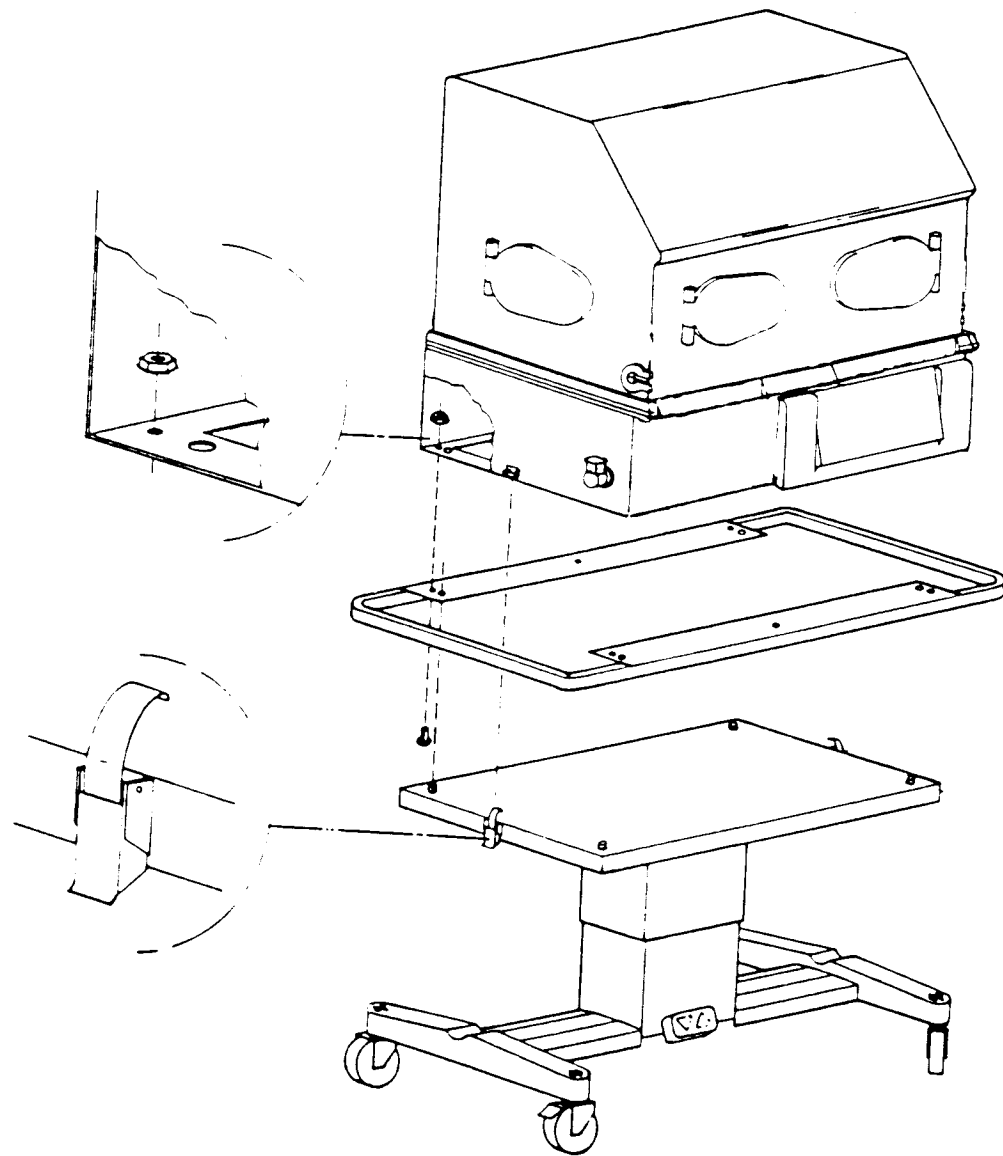

FIGURE 2.2 ASSEMBLY, INCUBATOR MOUNTED ON VHA CABINET STAND

2.3 WARM WEIGH® INFANT SCALE, MODEL I20 (ACCESSORY)

For more information, refer to the I20/W30 Operator's Manual.

IMPORTANT: The Load Cell must be unlocked before operating the scale. Refer to the I20/W30 Installation, Test and Calibration Instructions for the procedure.

- A. OPEN FRONT ACCESS PANEL of the Incubator.
- B. REMOVE THE MATTRESS from the Incubator (refer to Figure 2.3).

IMPORTANT: Use the mattress provided with the scale. Use of the C400/C450 QT® mattress may cause inaccurate readings due to interference with the surrounding walls.

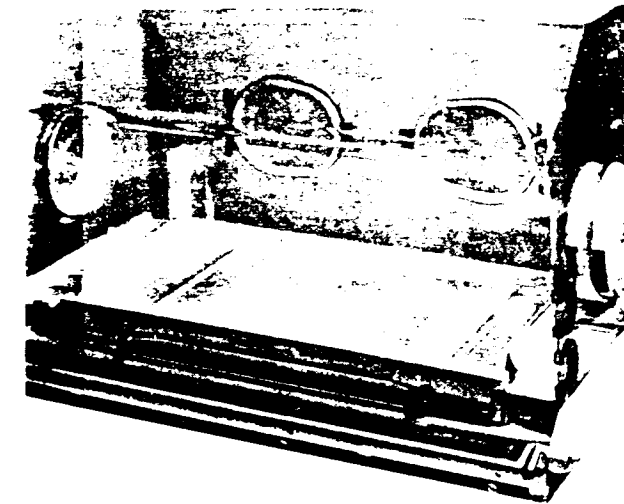

FIGURE 2.3 MATTRESS REMOVED FROM THE INCUBATOR

- C. INSTALL THE WEIGHING PLATFORM in the Incubator Mattress Tray (Figure 2.4). Make sure it is level.

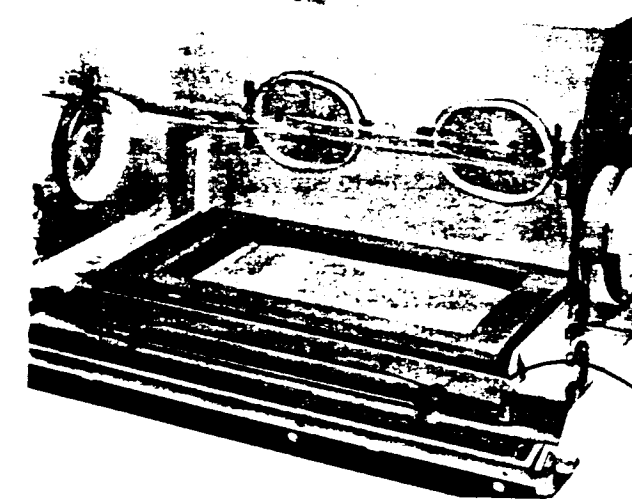

FIGURE 2.4 WEIGHING PLATFORM INSTALLED IN MATTRESS TRAY

- D. PLACE THE MATTRESS TRAY AND MATTRESS PROVIDED on the Weighing Platform (Figure 2.5).
- E. INSERT THE CABLE INTO THE HOOD ACCESS GROMMET (Figure 2.5).

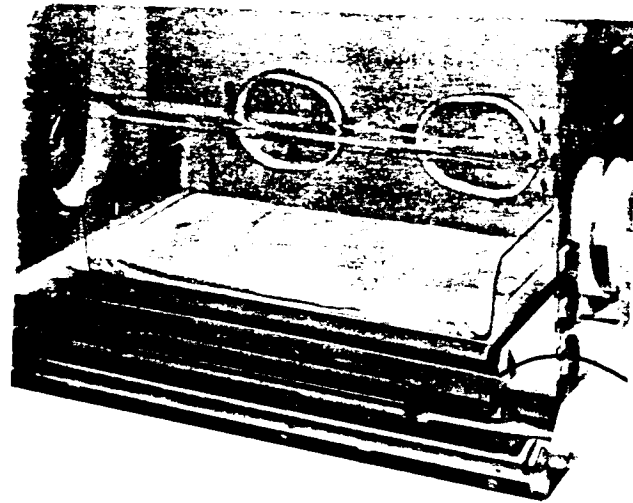

FIGURE 2.5 MATTRESS TRAY AND MATTRESS ON WEIGHING PLATFORM

2.4 GENERAL OPERATION AND FUNCTIONAL CHECKOUT PROCEDURE

The operational checkout should be performed before the Incubator is first placed into use and after any disassembly for cleaning or maintenance.

- A. **CHECK FOR LOOSE CASTERS (Standard Cabinet Stand Only)** by lifting each end of the Incubator approximately 2" and pulling down on each caster. A loose caster may fall out during use if Incubator is lifted over cables, door sills or elevator thresholds. This could result in Incubator tipping over when lowered to floor. Do not use Incubator until loose casters are replaced.

IMPORTANT: Two persons are required to perform this check – one to lift, one to check the casters. Lifting weight minimum is approximately 70 pounds. A block must be used to support the raised end in the event a caster falls out.

- B. **BEFORE CONNECTING THE INCUBATOR** to the power source, depress the **POWER** switch; the power failure alarm should sound and the **Power Fail** indicator should light. This tests the operation of the power failure alarm circuit and ensures that the rechargeable battery that powers the circuit is in good condition. Depress the **POWER** switch a second time to silence the alarm.

- C. **CONNECT THE AC POWER CORD** directly to the Incubator when the Incubator is mounted on a Standard Cabinet Stand. **CONNECT THE AC POWER CORD** to the VHA Stand ac power outlet when the Incubator is mounted on a VHA Stand (Option). The Incubator power cord should be connected to the VHA Stand receptacle to prevent accidental disconnection or damage when the Incubator is raised or lowered.

CAUTION: Make sure that the building power source is compatible with the electrical specifications shown on the right side of the Incubator and VHA Stand. For proper grounding reliability, connect the power cord only to a properly marked 3-wire hospital-grade or hospital-use receptacle. Do not use extension cords.

The following CAUTIONS should be observed when the Incubator is mounted on a VHA Stand.

CAUTION: HEAVY EQUIPMENT – To prevent injury or damage to the Incubator/Stand, when transporting, two persons of sufficient strength are required to adequately control the Incubator.

CAUTION: Always lower the Incubator to its lowest position prior to transport for optimum stability.

- D. **CHECK THE VHA STAND ADJUSTMENT.** Turn on the Main Power Switch. Use foot to depress the right portion of the VHA Stand Up/Down Switch to raise the stand to the maximum height. Depress and hold the left portion of the VHA Stand Up/Down Switch to lower the stand to the minimum height. Verify the stand operates smoothly and readjust to desired height.

WARNING: Always place one hand on the Incubator for support when adjusting height to prevent losing balance.

- E. **DEPRESS THE POWER SWITCH.** The switch should light. When initially turned on, the Controller performs a 5-second self-test; all **Alarms** Indicators light, all **Mode** Indicators light, all **Heater Power %** Indicators light, the audible alarm is pulsed, and each digital display shows all eights. If any function does not occur, or digital display is missing a segment(s), the unit requires service.

IMPORTANT: This test should be performed on a daily basis.

- F. **SET THE SET TEMP °C DISPLAY TO 33.0 °C.** All five **Heater Power %** Indicators should light, indicating full heater output.

NOTE: Allow the unit to operate while continuing the operational checkout.

- G. **CHECK HOOD HINGE AND LATCH OPERATION** for proper positioning. Using the Hood Lift handle, slowly tilt the Hood back until the Hood Latch engages. Close the Hood by releasing the Hood Latch as shown in Figure 2.6.



FIGURE 2.6 HOOD RELEASE OPERATION

- H. **CHECK ACCESS PANEL DETENT.** Rotate both latch/releases inwardly and open the Access Panel as shown in Figure 2.7; the Air Curtain Cover should rise slightly as the Access Panel opens, and the detents should create a noticeable "drag" during initial movement of the panel. Pivot the Access panel to the full open position (hanging straight down).

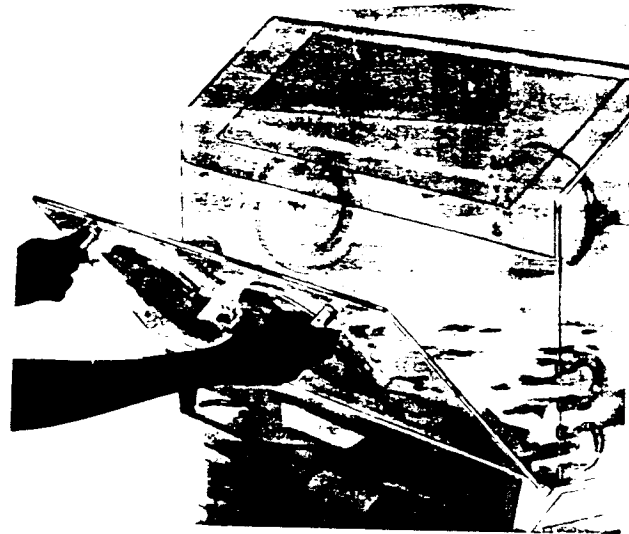

FIGURE 2.7 ACCESS PANEL OPERATION

- I. **CHECK IRIS ENTRY PORTS.** Rotate the outer ring of each Iris Port; the iris should open and close as rotation is continued through 360 degrees.

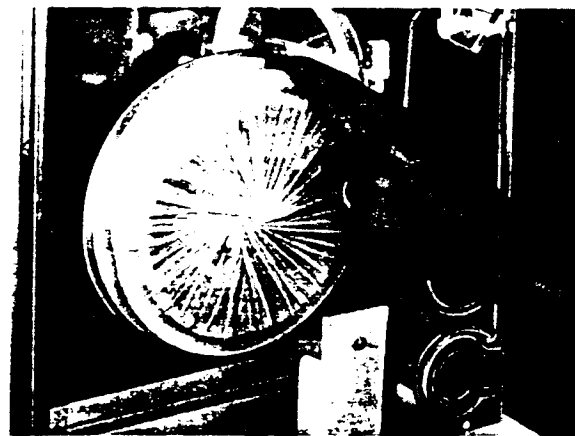

FIGURE 2.8 CHECK THE IRIS ENTRY PORTS

- J. **CHECK ACCESS PANEL LATCHES** by closing the Access Panel and rotating both latches until fully engaged. Both latches must be fully engaged to avoid accidental opening of the Access Panel.

- K. **CHECK ACCESS DOOR LATCH.** Press the door release of each Access Door (Figure 2.9). Each Access Door should swing open. Close the doors and check for proper latching and quietness.



FIGURE 2.9 ACCESS DOOR OPERATION

- L. **CHECK MATTRESS ELEVATORS.** Rotate the right mattress tilt mechanism handle (Figure 2.10) clockwise until it stops. The right end of the mattress should be at a 9 degree angle. Rotate the handle counterclockwise until it stops. The mattress should be level. Repeat the procedure using the left mattress handle.

WARNING: Do not attempt to raise the Hood when the mattress is raised.

IMPORTANT: Be sure that all the thumb screws that secure the Mattress Tilt Mechanism to the Deck are fully tightened to ensure Mattress Tray stability.

NOTE: These Elevators are provided to permit the infant to be positioned in the Trendelenburg or Reverse Trendelenburg position. Do not elevate both ends of the mattress at the same time except for possible use during magnification X-ray procedures. Never leave the infant unattended while both elevators are raised.

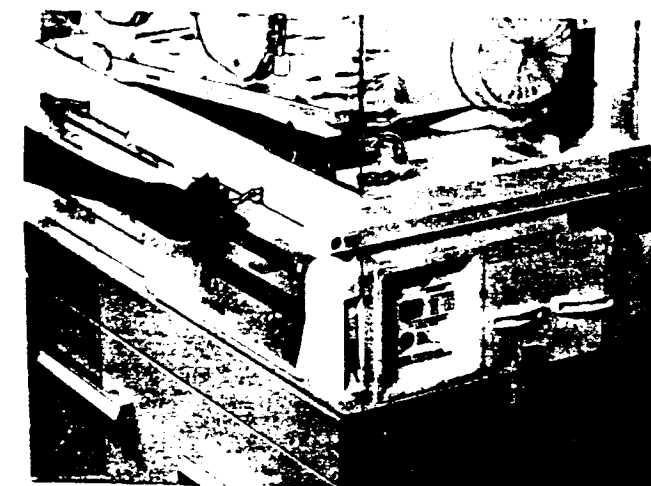

FIGURE 2.10 MATTRESS TILT HANDLES

- M. **CHECK MATTRESS TRAY** by sliding it out to the fully extended position as shown in Figure 2.11. Lean on Mattress Tray; make sure it is properly supported to provide a firm infant platform.

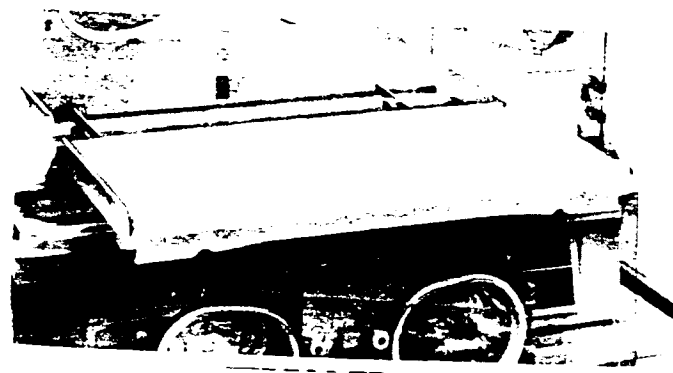

FIGURE 2.11 MATTRESS TRAY OPERATION

WARNING: A dirty Air Intake Microfilter may affect oxygen concentrations and/or cause Carbon Dioxide build-up. The filter must be checked on a routine basis and changed at least every three months.

- N. **CHECK THE AIR INTAKE MICROFILTER.** Loosen the two thumb screws of the Air Intake Filter Cover and remove the cover as shown in Figure 2.12. Inspect the microfilter; if visibly dirty, it should be replaced. Refer to Paragraph 5. for additional instructions.
- O. **CHECK AIR/OXYGEN SYSTEM** by introducing a carefully measured 8 lpm of oxygen into the optional Oxygen Input Valve, then monitoring levels within hood to verify that they reach the predicted level as indicated on the Filter Cover Assembly.



FIGURE 2.12 FILTER COVER REMOVAL

- P. **CHECK AIR CONTROL MODE OF OPERATION.** With all access openings closed, allow the Incubator to warm up to the **Set Temp °C** Display setting (33.0 °C); it should take less than one hour. While the unit is warming up, suspend the Auxiliary Probe through the hole in the top of the Incubator Hood and position the patient probe on the center of the mattress surface; do not connect the probe plugs to the receptacles. When the **Air Temperature °C** Display has stabilized, the number of **Heater Power %** Indicators illuminated will typically be reduced to no more than two. Check that the **Air Temperature °C** Display remains within 0.5 °C of **Set Temp °C** Display for 15 minutes after stabilization.

- Q. **CHECK AUXILIARY PROBE.** Insert the Auxiliary Probe connector into the **AUXILIARY AIR PROBE** receptacle. When the **Air Temperature °C** Display has stabilized, the number of **Heater Power %** Indicators illuminated will typically be reduced to no more than two. Check that the **Air Temperature °C** Display remains within 0.5 °C of **Set Temp °C** Display for 15 minutes after stabilization.
- R. **CHECK BABY MODE CONTROL* OF OPERATION.** Connect the Patient Probe plug to the **PATIENT PROBE** Receptacle and select **Baby Mode Control**. Set the **Set Temp °C** Display to 36.0 °C. Locate the sensor to control air temperature above center mattress. If the **Set Temp** alarm actuates, depress the **Silence/Reset** Key.
- S. **CHECK BABY SET TEMP ALARM.*** Allow Incubator Temperature to stabilize at 36.0 °C. Set the **Set Temp °C** Display to 37.5 °C; the Set Temp Indicator should be on. Change the **Set Temp °C** Display to 34.0 °C; the current alarm should cancel. Return the set temperature to 36.0 °C.
- T. **CHECK PATIENT PROBE ALARM.*** Disconnect the Patient Probe from the receptacle. The audible and visual alarms should activate, the **Baby Temperature °C** Display should blank, and the **Heater Power %** Indicators should all go off. When the Patient Probe is reconnected, the Incubator should return to normal operation after the **Silence/Reset** Key is pressed.
- U. **CHECK AIR FLOW ALARM.** Set the **POWER** switch to off. Remove the Controller from the Incubator. Remove the fan impeller from the fan motor shaft and reinstall the Controller in the Incubator. Set the **POWER** switch to on and wait for the end of the Auto-Test cycle (5 seconds). Within 5 minutes, the **Air Flow** indicator should flash, a pulsating audible alarm should sound, and all **Heater Power %** Indicators should go out. Reinstall the fan impeller and restore the Incubator to normal operating condition before proceeding.
- V. **CHECK HIGH TEMPERATURE ALARM.** Position probe end of the auxiliary probe outside the Incubator. With the Keypad is locked, simultaneously press and hold the >37 °C Key and the Up Arrow Key for 3 seconds. The **Baby Temperature °C** Display should show [.] and the **Air Temperature °C** Display should show the current Incubator temperature and begin to rise. If the **Set Temp** Alarm actuates, press the **Silence/Reset** Key. When Incubator temperature reaches 39.5 ± 0.5 °C, the **High Temp** Indicator should come on and the audible alarm should sound. Press the Keypad Lock key to exit the High Temperature test mode. Return the auxiliary probe to the inside of the Incubator. When the Incubator temperature falls below 39.0 °C, press the **Silence/Reset** Key to cancel the **High Temp** Alarm.
- W. **CHECK THE OXYGEN INPUT VALVE FILTER.** The Oxygen Input Valve Filter Cartridge should be checked once every four months and replaced if the ends are gray or black. Refer to the Service Manual and qualified service personnel.
- X. **CHECKOUT IS COMPLETE.** Disconnect and store the Auxiliary and Patient Probes. If the Incubator is to be used, place it in **Air Mode Control** and leave the Incubator running until ready for use. If it is not going to be used, it may be shut off.

*Model C450 QT® only.

SECTION 3 TECHNICAL INFORMATION

3.1 SPECIFICATIONS

Specifications for the Incubators are provided in Table 1.1. All specifications are subject to change without notice. Open Access Doors or Panel or the use of infant seats, head hoods or other equipment or supplies within the Incubator, which can alter the air flow pattern, may affect temperature uniformity, temperature variability, the correlation of the Incubator temperature reading to center mattress temperature and infant skin temperature.

TABLE 3.1 SPECIFICATIONS

POWER REQUIREMENTS:	
Models C400-1 QT® and C450-1 QT®	120V ± 10%, 50/60 Hz, 500 W Maximum
Models C400-1E QT® and C450-1E QT®	220-240V ± 10%, 50/60 Hz, 500 W Maximum
Models C400-1E QT® and C450-1E QT® German	220V ± 10%, 50 Hz, 500 W Maximum
Models C400-1E QT® and C450-1E QT®	100V ± 10%, 50/60 Hz, 500 W Maximum
Chassis Leakage Current	.100 uA or less 100/120V units 500 uA or less 220 - 240V units
ALARMS:	
Air Flow	Activated by fan failure or a short-circuited Air Flow probe
Probe	Activated by a defective Air, Baby* High Temperature or Auxiliary probe or if the Baby* Temperature probe is disconnected from unit when operating in Baby* Mode. Also activated by an open-circuited Air Flow probe when the temperature sensed below deck is greater than 30 °C to 31 °C.
High Temp (High Temperature)	Activates if Incubator Temperature exceeds 39.5 ± 0.5 °C.
Set Temp (Set Temperature)	Activates if Baby* or Air Temperature fluctuates from set temperature as follows: In Baby* Mode—Baby Temperature + 1.0 ± 0.3 °C - 1.0 ± 0.3 °C In Air Mode—Air Temperature + 1.5 ± 0.5 °C - 2.5 ± 0.5 °C
Power Fail (Power Failure Alarm)	Activates if primary power to the incubator fails or the power cord is accidentally disconnected from the wall receptacle.
System Fail (System Failure)	Internal malfunction, refer unit to Service.
*Model C450 QT® only	

(This page is intentionally left blank.)

TABLE 3.1 SPECIFICATIONS (Continued)

Silence/Reset	
Silence	Silences the Set Temp audible alarm for 15 minutes; alarm silence is automatically overridden if a subsequent alarm occurs within the period of silence. Silences Power Fail audible alarm for 2 minutes
Reset	Cancels High Temp. Air Flow or Probe Alarm if alarm condition no longer exists.
TEMPERATURE CONTROL RANGES:	
Air Mode Control	20.0 to 37.0 °C 37.0 to 38.5 °C, Temperature Override Mode
Baby Mode Control*	34.0 to 37.0 °C 37.0 to 37.9 °C, Temperature Override Mode
Temperature Rise Time**	<50 minutes
Temperature Variation**	1.5 °C
Temperature Overshoot**	0.5 °C maximum
Temperature Uniformity**	1.0 °C.
Correlation of Indicated Air Temperature to Actual Incubator Temperature** (after Steady Temperature Condition** is reached)	
Air	± 1.0 °C
Baby	± 0.5 °C of set temperature up to 38.5 °C ± 0.3 °C of set temperature up to 37.9 °C
Oxygen Concentration Range	Ambient to >70%
Humidity (with no supplemental O ₂ Set Temp °C >32 °C and ambient temp. 20–30 °C.)	Typically between 50 and 60% with water in humidity reservoir
NOMINAL DIMENSIONS:	
Height from Floor	140 cm (55")
Depth	56 cm (22")
Width	116 cm (45.5")
Nominal Weight (without accessories)	76 Kg (168 lbs)
Mattress Tilt	
Trendelenburg/Reverse Trendelenburg	0° ± 9° Continuously Variable
*Model C450 QT® only	
**Refer to Table of Definitions and Symbols	

TABLE 3.1 SPECIFICATIONS (Continued)

ENVIRONMENTAL	
Temperature:	
Operating Range	+20 °C to + 30 °C Ambient
Storage Range	-30 °C to + 70 °C Ambient
Humidity:	
Operating Range	5% to 95% RH Non-Condensing
Storage Range	0% to 99% RH Non-Condensing
Noise Level Within Hood Environment	< 49 dBA maximum with 50 dBA or less ambient
Air Velocity Over Mattress	Does not exceed 25 cm/sec (50 ft/min.) within Control Zone.**
VHA STAND (Optional)	
Power Requirements (including Incubator)	120V, ± 10%, 60 Hz, 600 W, Nominal 220–240V, ± 10%, 50/60 Hz, 600 W, Nominal 220, ± 10%, 50/60 Hz, 600 W, Nominal (German)
Chassis Leakage Current	120V units (including Incubator) less than 100 uA 220V – 240V units (including Incubator) less than 500 uA
Height Range (VHA Stand)	
Low	60.3 cm (23 3/4")
High	81.9 cm (32 1/4")
Depth	53.3 cm (21")
Width	113 cm (44 1/2")
Weight	95.2 kg (210 lbs)
Height Range (Incubator Mattress)	
Low	87.6 cm (34 1/2")
High	109 cm (43")
Weight (with Incubator mounted)	140.6 kg (310 lbs)
*Model C450 QT® only	
**Refer to Table of Definitions and Symbols	

3.2 THEORY OF OPERATION

3.2.1 GENERAL

This section contains a functional description and detailed theory of operation of the equipment. A system block diagram of the Controller is shown in Figure 3.3.

3.2.2 OVERALL FUNCTIONAL DESCRIPTION

The control of temperature, humidity, and oxygen concentration is achieved by means of the forced air circulation system as shown in Figures 3.1 and 3.2. A controlled amount of room air (approximately 35 lpm) is drawn through the air intake filter by means of the motor-driven impeller on the Controller.

Supplemental oxygen, which may be introduced through the Oxygen Input Valve on the air intake filter cover, displaces a portion of room air to maintain the total gas intake (including oxygen) at 35 lpm. Since the amount of room air is controlled by the impeller/filter characteristics and the amount of oxygen is controlled by the flowmeter setting, predictable oxygen concentrations within the Incubator can be attained. When oxygen flow exceeds 8 lpm, a valve within the oxygen inlet housing is activated to restrict air intake so that higher oxygen concentration can be achieved without excessive oxygen flow. At 12 lpm maximum air intake restriction is achieved.

In addition to drawing fresh, filtered air into the Incubator, the impeller provides for the internal recirculation at a much greater flow than that of the fresh gas inflow. The total flow of fresh plus recirculated air is directed past the air flow sensor and around the heater with a predetermined portion being directed over the humidity reservoir for humidification. When the Access Panel of the Hood is closed, the Air Curtain Cover is closed and all the air enters the infant compartment up through the slot at the right end of the main deck as shown in Figures 3.1 and 3.2. After circulating within the infant compartment, the air is then recirculated down through the slot in the left end of the main deck, past the temperature sensing probe which encapsulates the air temperature control thermistor and a high air temperature alarm thermistor, and back to the impeller. When the Access Panel of the Hood is open, the Air Curtain Cover is raised permitting a portion of the air to flow upward past the opening (Figures 3.1 and 3.2) creating a warm air curtain which minimizes the drop in air temperature in the Incubator.

3.2.3 TEMPERATURE CONTROL

The Model C450 QT® Incubator temperature is regulated using either Incubator air or infant's skin temperature as the controlling parameter; the desired mode is selected by a front panel key. The Model C400 QT® Incubator provides only **Air Mode Control**.

In either mode of operation, the heater output is proportional to the amount of heat required to maintain the desired temperature, and the relative amount of heat being provided is indicated by the number of lit **Heater Power %** Indicators on the front panel. Changes in the number of lamps illuminated indicate the amount of power required to maintain a given temperature. During **Baby Mode Control**, the Model C450 provides an indication of the degree of the infant's dependency upon the temperature of its environment to maintain body temperature. Each mode of operation is described below.

AIR CONTROL MODE (MODELS C400 QT® and C450 QT®). In this mode of operation, the air temperature can be maintained from 20.0 to 37.0 °C (20.0 to 38.5 °C Temperature Override Mode) as indicated by the **Set Temp °C** Display setting. The Incubator air temperature is monitored by a probe located below deck and compared with the **Set Temp °C** Display setting. The information from this probe is supplied to the heater control circuitry which proportions the heater output to maintain Incubator air temperature at the **Set Temp °C** Display setting. Actual air temperature is displayed by the **Air Temperature °C** Display. A second sensor within the air temperature probe serves as a backup to limit the Incubator temperature to between 39 °C and 40 °C; at this temperature, an alarm is activated, the heater is shut off.

If desired, an auxiliary air temperature probe can be used to control the Incubator air temperature. This probe is suspended above the mattress through the weighing scale hole and plugged into a special receptacle on the side of the Incubator. When plugged in, the primary air temperature control probe is disconnected, but the backup sensor within the primary temperature probe remains connected. Thus, the auxiliary probe becomes the controlling element for the air temperature.

In the **Air Mode Control** of operation, the infant's temperature will be a function of the air temperature and the infant's ability to establish and maintain its own temperature. A small infant, or one with underdeveloped homeostatic control, may not be able to maintain a stable temperature at the desired level.

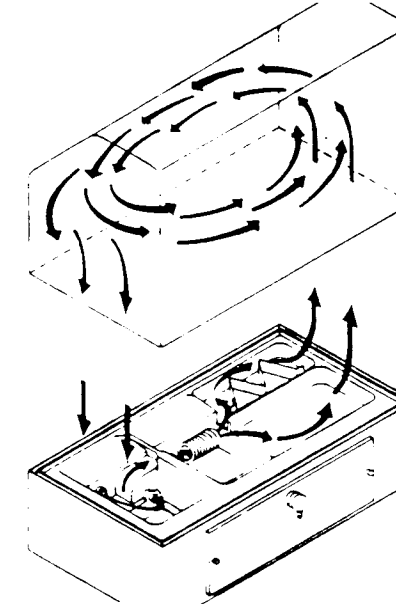

AIR CIRCULATION WITH INCUBATOR DOOR CLOSED

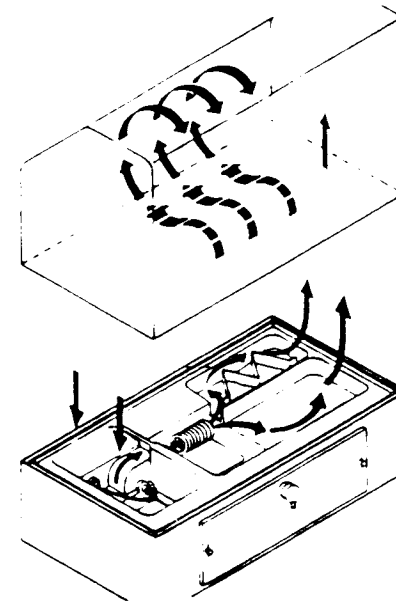

AIR CIRCULATION WITH INCUBATOR DOOR OPEN

FIGURE 3.1 AIR/O₂ CIRCULATION SYSTEM – GROUP 1

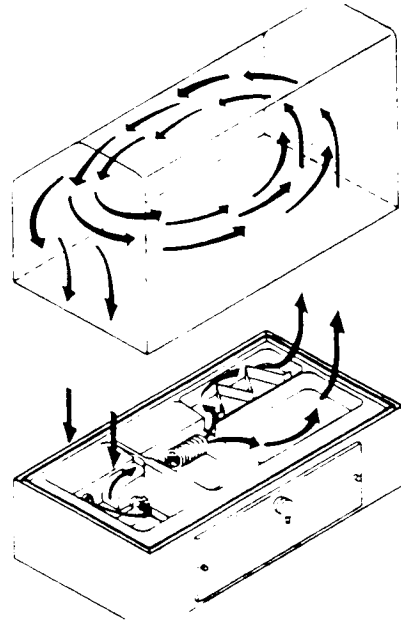

AIR CIRCULATION WITH INCUBATOR DOOR CLOSED

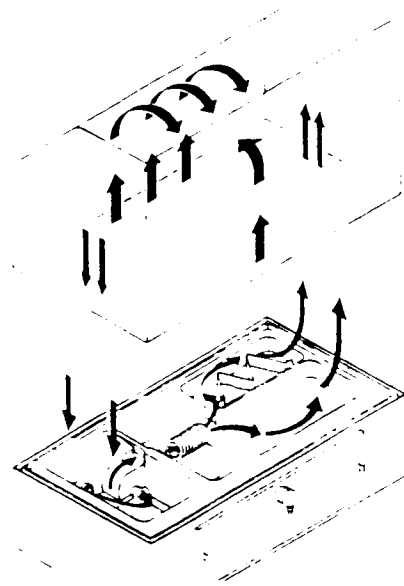

AIR CIRCULATION WITH INCUBATOR DOOR OPEN

FIGURE 3.2 AIR/O₂ CIRCULATION SYSTEM - GROUP 2

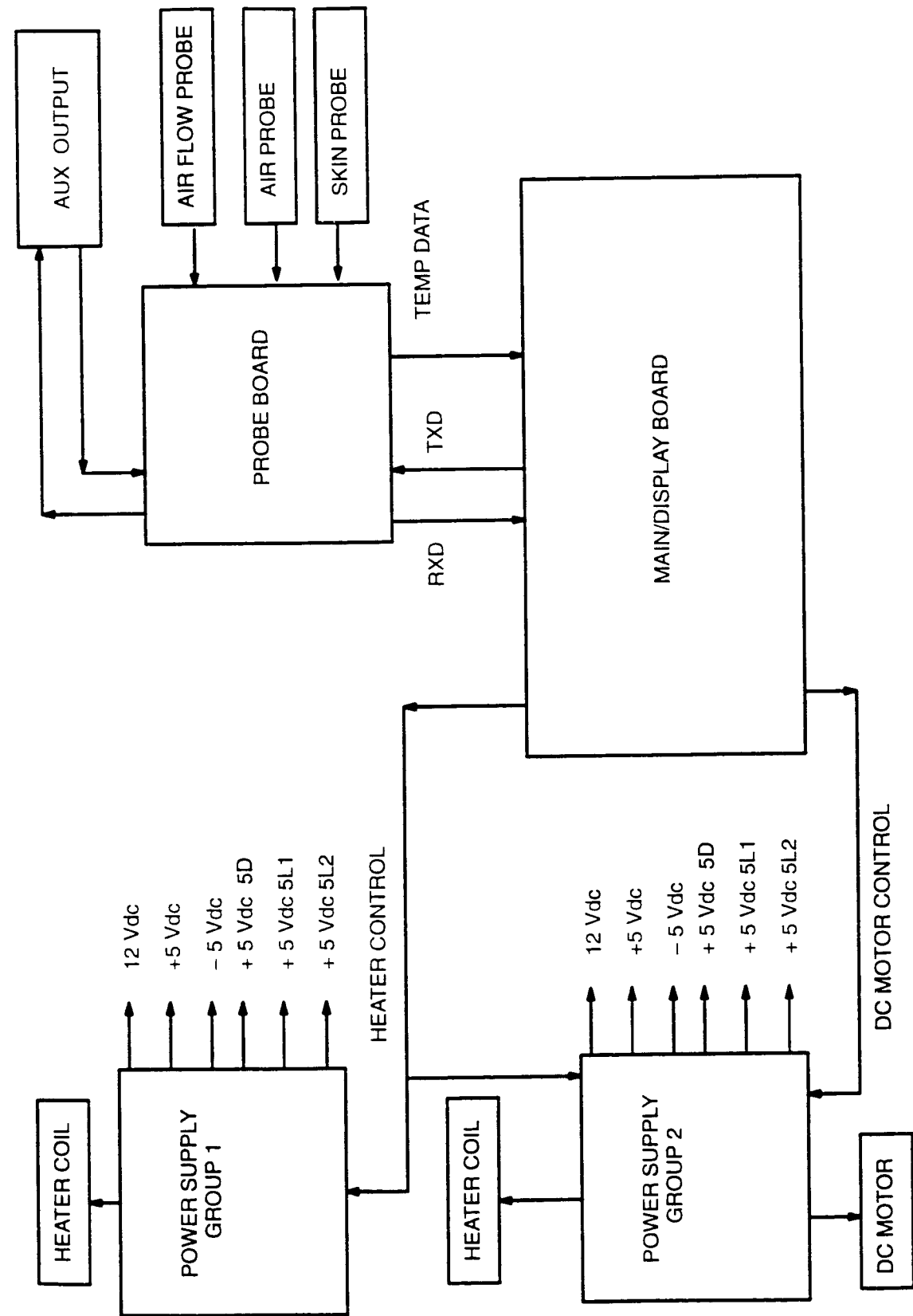

FIGURE 3.3 CONTROLLER FUNCTIONAL BLOCK DIAGRAM

BABY MODE CONTROL (MODEL C450 QT® Only). In this mode of operation, the infant's skin temperature can be maintained as indicated by the **Set Temp °C** Display from 34.0 to 37.0 °C (37.0 to 37.9 °C in Temperature Override Mode). A temperature sensing probe is attached directly to the infant's skin; the information from the probe is supplied to the heater control circuitry which proportions the heater output to maintain the Baby's Temperature at the **Set Temp °C** setting. Actual baby temperature is displayed by the **Baby Temperature °C** Display. The **Set Temp °C** setting does not control air temperature while in **Baby Mode Control**, but air temperature is still displayed. The air temperature is still limited to 38.5 °C. If the **Air Mode Control** is selected while the skin probe remains connected, the **Baby Temperature °C** Display will continue to display actual skin temperature, but will not control.

If the probe is disconnected from its receptacle during **Baby Mode Control** of operation, the **Baby Temperature °C** Display blanks and a probe alarm is activated. The **High Temp** alarm sensor within the Air Temperature probe remains in the circuit to limit the air temperature to less than 40.0 °C.

3.2.4 ALARMS

Alarms are provided for **Power Fail, System Fail, inadequate Air Flow, Probe Fail, High Temp** and variation from **Set Temp**. Each time the unit is turned on, the unit is automatically stepped through an alarm check sequence to verify proper alarm function. After the automatic alarm check is made, the low **Set Temp** alarm is disabled for 60 minutes or until the temperature reaches the **Set Temp °C** setting, whichever occurs first; each of these alarms is described below.

AIR FLOW. A sensor located below deck in the normal air path of the fan controls this alarm. If air flow stops due to a fan failure, the temperature of the self-heated sensor rises causing the **Air Flow** alarm Indicator on the front panel to light and produce a pulsating audible tone. A short-circuited air flow sensor failure will also actuate the alarm within 10 seconds of the occurrence of the failure. This alarm is not self-resetting and cannot be silenced and cannot be canceled by the **Silence/Reset** Key until the alarm condition is corrected.

HIGH TEMPERATURE. A second sensor within the Air Temperature Probe sounds this alarm if the Incubator temperature reaches 39.5 ± 0.5 °C. A **High Temp** alarm is indicated by a flashing light and a continuous audible tone. This alarm is not self-resetting and cannot be canceled by the **Silence/Reset** Key until the alarm condition is corrected.

POWER FAILURE. If primary power to the Incubator is interrupted for any reason, including a disconnected power cord, an audible alarm is activated and the **Power Fail** Indicator lights. This alarm can be silenced for two minutes by the **Silence/Reset** Key. This alarm can be deactivated only by restoring the primary power or setting the Incubator POWER Switch off.

SYSTEM FAIL. If an internal malfunction is detected, the **System Fail** Indicator will flash and the audible alarm will sound. This alarm is not resettable and the unit should be referred to qualified service personnel.

PROBE. Circuitry is provided to monitor the air, skin and high temperature sensors for short-circuited, open-circuited, or disconnected conditions and the air flow sensor for open condition.

In the Model C450 QT® Incubator, a **Probe** indicator light flashes and an audible alarm sounds within 10 seconds to indicate a defective air temperature, baby temperature or auxiliary air sensor or an open-circuited air flow sensor (see **IMPORTANT**). The **Probe** alarm is also activated if the skin temperature probe is disconnected while in the **Baby Mode Control**.

The Model C400 QT® Incubator is equipped only for air control; therefore, no baby probe alarm is provided. The **Probe** alarm is activated to indicate a defective air temperature or auxiliary sensor or an open-circuited air flow sensor (see **IMPORTANT**).

IMPORTANT: *The probe alarm will be actuated within 10 seconds if the air flow sensor is open-circuited and the temperature sensed below the mattress deck is greater than approximately 30 °C; however, if the temperature sensed below the mattress deck is less than approximately 30 °C, the alarm will not be activated. During warm-up, it can take anywhere from 15-30*

minutes before the alarm actuates, depending on the temperature set point and ambient room temperature. The probe alarm indicating an open-circuited air flow sensor will not occur if the high Set Temp is below 29 °C.

In either Incubator, if a probe shorts (except for the air flow probe or high temperature alarm probe), it will also appear as a **Set Temp** violation, and the **Set Temp** alarm will light. This alarm is not self-resetting and cannot be canceled by the Alarm **Silence/Reset** Key until the alarm condition is corrected. If a **Probe** alarm occurs simultaneously with a **Set Temp** alarm, a shorted probe is probably the true cause of the alarm, since a shorted probe will appear as a high temperature condition.

SET TEMP. The **Set Temp** alarm is actuated if baby or air temperature fluctuates from set temperature as follows:

*Baby Temperature	+1.0 ± 0.3 °C
	-1.0 ± 0.3 °C
Air Temperature	+1.5 ± 0.5 °C
	-2.5 ± 0.5 °C

A temperature below the **Set Temp** is indicated by a flashing light, an audible tone, and the set temperature setting alternating with LO in the **Set Temp °C** Display; a temperature above the **Set Temp** is indicated by a flashing light, an audible tone, and the set temperature setting alternating with HI in the **Set Temp °C** Display. If a **Set Temp** alarm occurs simultaneously with a **Probe** alarm, a shorted probe is probably the true cause of the alarm, since a shorted probe will appear as a high temperature condition.

The **Set Temp** alarm is self-resetting; that is, if the alarm condition is corrected, the audible alarm is automatically silenced and the light is turned off.

The audible **Set Temp** alarm can be silenced by depressing the **Silence/Reset** Key; the activation of other audible and visual alarms will not be affected by use of the 15-minute audible alarm silence.

When silenced, the alarm indicator will remain on until the alarm condition is corrected. If the alarm condition is not corrected within 15 minutes, the audible alarm will be reactivated.

In addition, if it is desired to change the Air or Baby Set Temperature (either High or Low) after the Incubator is in operation, the Set Temp HI and LO alarms are automatically silenced for a specific amount of time after the operator raises or lowers the Air or Baby Set Temp from the current operating temperature. The time the alarm remains silent is 5 minutes per degree (plus or minus) change from the current set temperature.

Example: A 1.5 degree (plus or minus) change from set temperature will generate an alarm silence period of 7.5 minutes.

If the Incubator fails to reach the new set temperature after the specified time, the alarm will sound.

3.2.5 VERTICAL HEIGHT ADJUSTABLE STAND (OPTION, REFER TO FIGURE 1.1)

The Vertical Height Adjustable Stand provides the C400 QT® and C450 QT® Incubators with the capability of varying Incubator height over a range of 8 1/2 inches. The VHA Stand is powered by an electric motor which is controlled by a momentary up/down foot switch. The VHA Stand has its own power cord and provides power to the Incubator which is mounted on it. In addition, if the VHA Stand circuit breaker opens, power will still be provided to the Incubator which is protected by its own circuit breaker.

3.2.6 CONTINUOUSLY VARIABLE MATTRESS TILT MECHANISM

The C400 QT® and C450 QT® Incubators are equipped with a 0 to ± 9 degree continuously variable Mattress Tilt Mechanism which permits placing the infant in the Trendelenburg or Reverse Trendelenburg position.

*Model C450 QT® only.

3.2.7 QUIET LATCH ACCESS DOORS

The C400 QT® and C450 QT® Incubators are equipped with quiet latching access doors. The latch mechanism of these doors is designed such that the doors may be opened with an elbow one at a time or simultaneously.

3.2.8 SWIVEL SHELVES, CABINETS AND DRAWERS (ACCESSORIES)

The C400 QT® and C450 QT® Standard Cabinet Stand or VHA Stand may be equipped with up to four post-mounted swivel shelves. The VHA Stand may be equipped with one or two Cabinet or Drawer Modules or one of each. These Modules may also be equipped with fold-down Side Shelves. The Cabinet is available with a metal or see-through (acrylic) door, or no door at all.

3.3 DETAILED CIRCUIT DESCRIPTION

3.3.1 POWER SUPPLY

GENERAL

The Power Board supplies all necessary voltages to the Controller. All DC voltages are generated by linear voltage regulators U1 through U6. Transformer T1 has a dual primary and two secondary windings.

+12 and -5 VDC are produced by center-tapped secondary windings along with full wave rectifier bridge CR1 and capacitors C9 (+12) and C10 (-5). Rectified DC is then regulated by U1 (+12) and U6 (-5). Regulator U2 delivers +5V to the analog circuitry.

The display LED and digital circuitry are powered from second windings with rectifier CR2 and capacitor C5. This raw DC is then regulated down to 5V by U3, U4, and U5. Three regulators are used in order to share load current.

HEATER CONTROL

The HEATER is controlled by U7 and Q2. Logic level SSR CTRL signal (J7-7) is applied to input LED of the optocoupler U7. This optocoupler (MOC3041) has a triac output with a zero-crossing detector. The output of U7 is then applied to power triac Q2 which in turn switches power to the heater.

In order to maintain safety standards, mechanical relay K1 is used in series with Q2. Logic level control signal HTR CUT (J7-5) is applied to MOSFET transistor Q1 which turns relay K1 ON and OFF.

LINE REFERENCE

In order to maintain fast system response, AC line voltage is monitored. This circuitry rectifies AC voltage from transformer secondary with CR4, filters it by C8 and is applied to RT1. Voltage divider output (J7-3) then represents AC line voltage.

MOTOR CONTROLLER (IEC CONTROLLERS ONLY)

The DC motor is controlled by U8, with feedback from the motor's hall effect sensors conditioned by U9A, B and C. The motor speed is locked in by the signal SET - RPM from the microcontroller into U9-D and further conditioned by U10B. A scaled value of the motor current (MOT-I) is outputted by U10A and applied to the microcontroller.

3.3.2 MAIN/DISPLAY BOARD

MCU

The microcomputer circuitry of the Main/Display board consists of microcontroller U10 (80C552) with U11 (PSD312) a peripheral chip.

All necessary decoding functions are performed by PAL block of U11. In addition, U11 has 2 general purpose I/O ports.

WATCHDOG TIMER AND RESET

The Watch Dog function is performed by U13 (DS1232). Microcontroller U10 toggles I/O port P1.2 which is connected to WDT input of U13. Should the microcontroller stop toggling for any reason, U13 resets it and generates audible signal during the reset.

KEYPAD

The Keypad is sampled on the port PA of the U11. Each key is decoded and processed by the microcontroller. All keys except the SILENCE/RESET key are normally open momentary switches with pull-up resistors to the +5D supply. The SILENCE/RESET key is pulled-up to VNV in order to remain active during the power failure.

SIGNAL CONDITIONERS

All temperature signal conditioner circuitry are identical. Each thermistor is connected in series with precision (0.1% tolerance) resistor to produce a voltage divider. This voltage is multiplexed by U16 and sampled by A/D converter U4. The software algorithm is used to translate the divider voltage into temperature units.

ALARMS

High Temperature Alarm

Voltage from the AIR monitor signal conditioner is fed into amplifier U9C. Its output is adjusted by RT2 to eliminate all tolerances in components. The output of amplifier U9C (TP2) is measured by comparator U1A against proper the threshold. When inputs drop below threshold (temperature rises), the comparator output becomes 0 (Low) which is sensed by both the microcontroller and PAL U6.

Set Point Alarm

Set point alarms are based on comparison between the SET POINT and actual temperature measured by the thermistors. The detection algorithm is implemented in software.

System Fail

Most hardware functions of the system are monitored by the microcontroller. In the case of MCU failure, the Watch Dog circuitry (U13) produces reset pulses along with audible beep and SYSTEM FAIL LED flashes. This function is carried out by the PAL chip U6. In addition, should port P3.5 (HDW FAIL) of the microcontroller fail and remain High (default), resistor R28 shall assert hardware fail condition into PAL and produce an audible and visual (via SYSTEM FAIL LED) indication.

Power Fail

The microcontroller circuitry is powered from nonvolatile (VNV) power source as long as MAINS power switch remains ON. Should a power failure occur during the normal operation, the microcontroller detects it and produces a POWER FAIL alarm (both audible and visual). Both control signals PWR FAIL (PA.0 of the-PSD312 chip) and AUDIO (P4.6 of the MCU) are pulled to VNV by RN2C and RN2B respectively. This assures proper alarm condition.

Probe Fail

All probes failures are detected by the MCU. In the case of the AIR monitoring probe, there is also a hardware back-up circuit. The output voltage signal from U9C (TP2) is fed into positive input of the comparator U1D. The negative input of U1D is biased to a constant reference which is equivalent to temperature levels >50 °C.

Air Flow

The AIR FLOW circuitry is based on the self-heating effect of the thermistor. If power is applied to the thermistor, the temperature of the thermistor is raised due to power dissipation. It will continue to rise until power dissipation into environment becomes equal to power generated by $12Rt$. From this point on there will be a thermal equilibrium and thermistor's temperature will be stable. This steady state temperature is directly proportional to the dissipation constant of the thermistor packaging. Any forced air which is pushed onto the thermistor will change this dissipation constant and thus steady state temperature of the thermistor. Since the temperature of the thermistor relates to its resistance, any such changes can be detected and/or measured by electronic circuitry.

The C400/450 circuitry senses voltage across AIR FLOW thermistor which is connected in series with R57 and powered from a 12V source. Differential amplifier U9D has a gain of 0.307 and its output is connected to MCU internal A/D converter. The software algorithm then makes determination with regard to air flow and sounds an alarm and cuts off the heater when the air flow drops below an acceptable level.

A/D CONVERTER

Digitizing of the temperature probe signals is done by A/D converter U4 which is a dual slot integrating 12 bit +sign analog to digital converter with direct binary outputs. These outputs are configured for an 8-bit bus and buffered by U3 (74245). The buffering is necessary due to the slow timing of the A/D converter's digital I/O. The following signals control A/D converter:

AD_RUN	(MCU P4.5)	Start of the conversion
AD_RDY	(MCU P3.3)	Conversion status
NAD_LEN	(PSD PB.5)	Enable Low output byte
NAD_HEN	(U2C)	Enable High output byte
NAD_RD	(PSD PC.2)	Read buffer

The A/D reference signal is adjusted by RT1 in order to get the most accurate reading for the thermistor channel.

POWER SUPPLY MEASUREMENT

All power supplies and battery voltage are read by the internal A/D converter of U10. These voltages are scaled by resistor dividers in order to bring all of them into A/D converter measurement range.

BATTERY CHARGER

The Battery Charger circuitry is built on PNP transistor Q5. The MCU monitors the battery voltage and makes a decision whether to charge it or not. If a charge is required, the MCU turns U5-28 low and transistor Q5 charges battery via limiting resistor R69.

DISPLAYS

The C400/450 displays are LED type. With the exception of 3 indicators, all of them are driven by special LED drivers U5, U7 and U8. These are serial input/parallel output shift registers with constant current sink outputs. The POWER FAIL and SYSTEM FAIL alarms' LEDs are driven by MOSFET transistors Q4 and Q2. The HIGH TEMP alarm LED is driven by U6-15 output.

AUDIO ALARM

The audio alarm is produced by Piezo transducer BZ1. The Oscillator is made up of inverters U17 (4049) and uses the transducer's capacitance as a timing element.

REMOTE ALARM INTERFACE

The Remote Alarm Interface consists of audio oscillator and RAM detector. The oscillator employs a standard 3 inverters scheme U2A, B and D. Since the inverters used are of the Schmitt trigger type, U12B is used to assure "half supply" switching level required by scheme. When the RAM Module is connected to the Controller, it generates "MUTE" signal (J6-5). This signal (-10 V DC) is divided by R17 and R26 and inverted by U2E. The output of U2E is fed into PAL (U6) which detects presence of the RAM. When a RAM is present, the audio control signal INC ALM is blocked and no audio can be produced by transducer BZ1. The only exception to this is case of power failure, when BZ1 oscillator is turned on by U12A. Should any other alarm condition occur, RAM oscillator is active at output U6-20 and drives RAM audio circuitry via J6-1.

AC LINE VOLTAGE CORRECTION

C400/450 heater control algorithm employs feed forward technique to compensate control for line variations. AC REF signal (J5-3) represents DC equivalent to line voltage. It is adjusted such that it always equals 4 VDC at nominal line and is buffered by U9B. Should line voltage deviate from nominal, this change is sensed by MCU internal A/D converter (P5.4) and software algorithm introduces necessary corrections to heater duty cycle.

DC MOTOR CONTROL (GROUP 2 CONTROLLERS ONLY)

DC motor control is done by MCU by controlling pulse width of the output U10-5. This is one of the 2 dedicated PWM ports of the 80C552 microcontroller.

3.3.3 PROBE BOARD

GENERAL

The Probe Board serves as an interconnection board to reduce cable harness and simplify controller assembly. This board is laid out to accept two types of PC mount connectors for temperature probes. The first type of connector will accept the single ended Patient Probe and the Auxiliary Air Probe. The other type accepts the dual thermistor Air Temperature Probe and the Air Flow Sensor. The proper electrical connections are maintained by selecting appropriate 0 Ohms resistors.

External connections (probes, RAM etc.) are protected against RFI/EMI by in-line chokes LN1 and LN2

SERIAL COMMUNICATION

The serial communication interface option (AUXILIARY PORT) provides an isolated communication port with RS232 compatible levels. It is based on the MAX2S0 and MAX2S1 chip set. The isolated power is provided via transformer T1. There are separate input (Rx D) and output (Tx D) data passes. In addition to galvanic isolation, this port is protected against RFI/EMI by in-line choke LN3.

SKIN PROBE CALIBRATION CHECK

During the calibration/check, the MCU issues "CAL-PRB" signal which turns relay K1 ON. This relay switches precision resistor R4 (4.300 K) in place of PATIENT PROBE and the system reads the temperature (36.00 ± 0.08 °C) which corresponds to the value of R4.

SECTION 4 PREVENTIVE MAINTENANCE

4.1 GENERAL

The section provides cleaning and maintenance instructions. Where necessary, disassembly instructions are provided. Maintenance other than that provided in this section should be performed only by qualified service personnel. Calibration procedures should be performed at 12 month intervals; refer to the Service Manual.

4.2 CLEANING

When an infant is discharged, or at least once a week, the Incubator should be thoroughly cleaned and disinfected. Cleaning can most effectively be accomplished by disassembling, then grouping the parts and/or assemblies in categories according to the method of cleaning required.

4.2.1 DISASSEMBLY FOR CLEANING

NOTE: For routine cleaning there is no need to separate the Hood/Base assembly from the Cabinet Stand. If separation is necessary, refer to the Installation Section.



WARNING: The Controller heater can be sufficiently hot to cause burns; avoid removing the Controller or touching the heater until the unit has been switched off for at least 45 minutes.

(This page is intentionally left blank.)

- A. **REMOVE THE CONTROLLER.** Disconnect the Power Cord and Probes from the side of the Incubator. Release the latch on each side of the Controller as shown in Figure 4.1, then withdraw the unit from the Incubator.

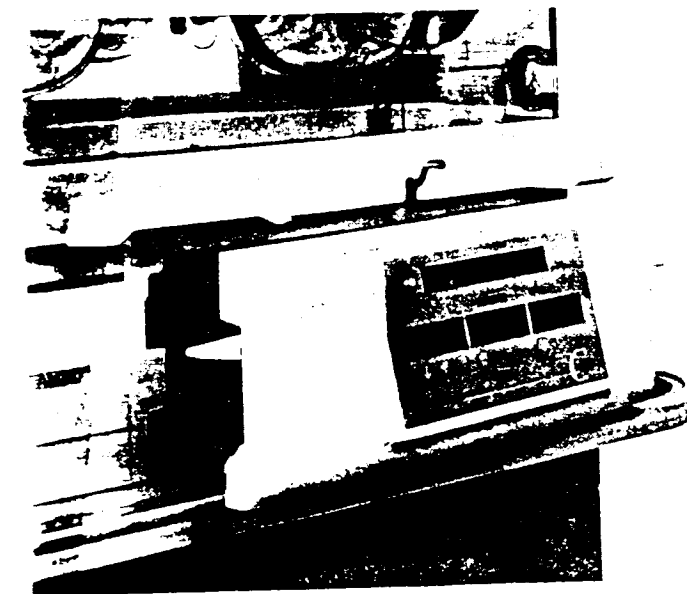

FIGURE 4.1 REMOVAL OF CONTROLLER

B. REMOVE THE MATTRESS TILT MECHANISM by loosening the thumb screws (Figure 4.2) that secure it to the Main Deck.

CAUTION: Both thumb screws must be fully tightened to ensure stable Mattress Tray Support.

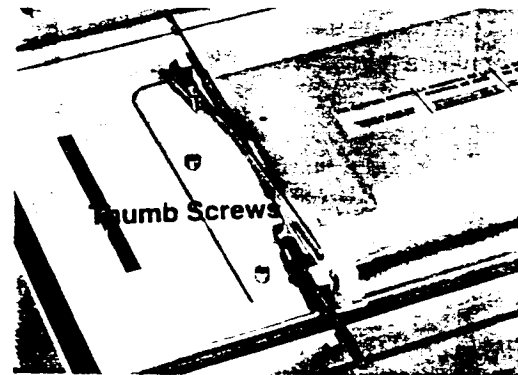
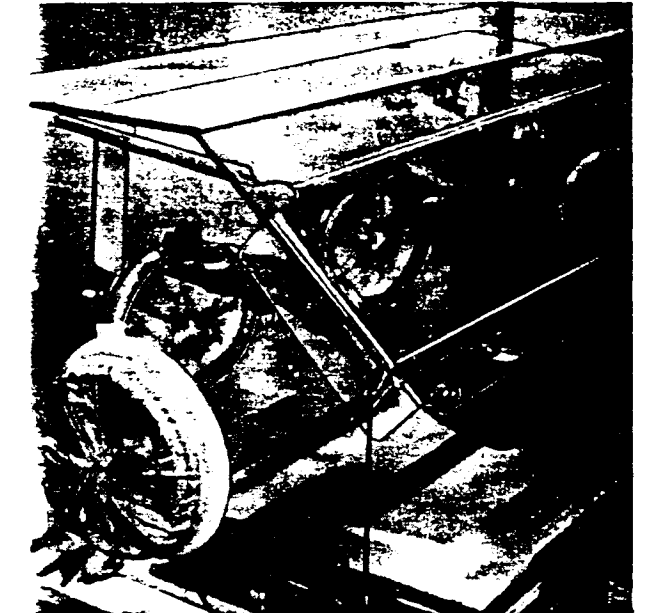

FIGURE 4.2 REMOVING THE MATTRESS TILT MECHANISM

C. REMOVE THE HOOD INNER WALLS. Remove the Inner Wall as described in Figure 4.3 or 4.4.



1. RELEASE FRONT OF INNER WALL by pushing slightly back in direction of Hood Slope, then pull down.



2. RELEASE REAR INNER WALL while resting front edge on Inner Wall on your arm, lift rear of Inner Wall, pull toward you to release, then lower.

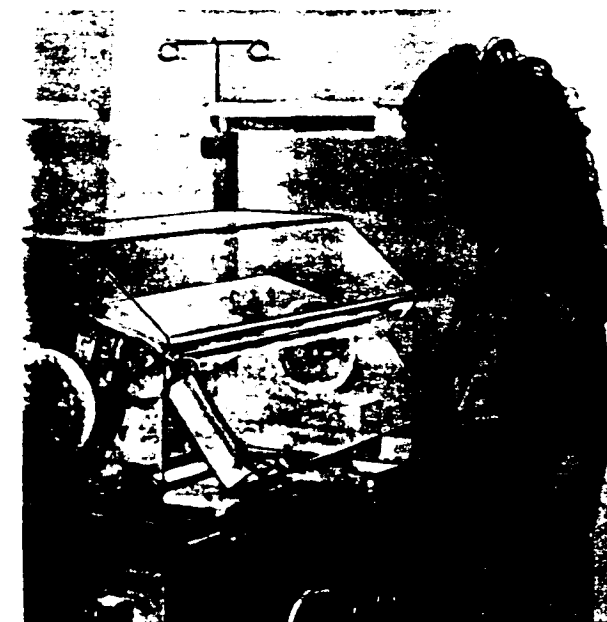

3. LOWER REAR OF INNER WALL AS LOW AS IT WILL GO.

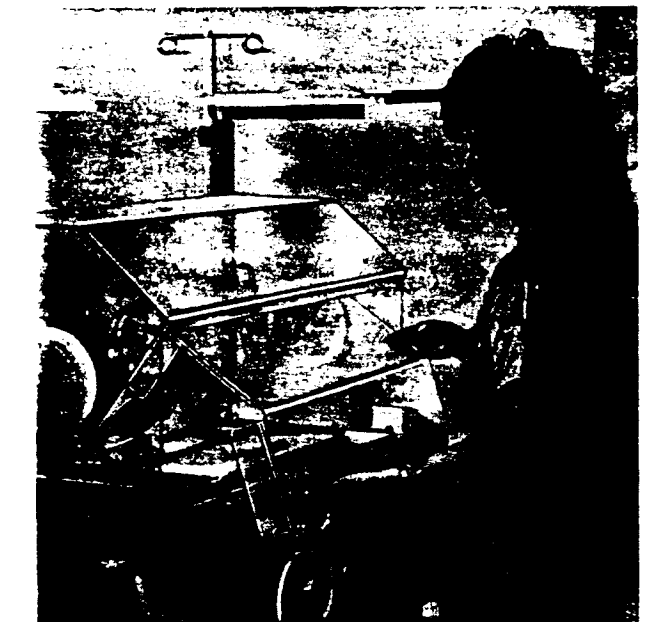

4. REMOVE INNER WALL by lowering it in the direction shown.

FIGURE 4.3 REMOVAL OF INNER WALL - GROUP 1

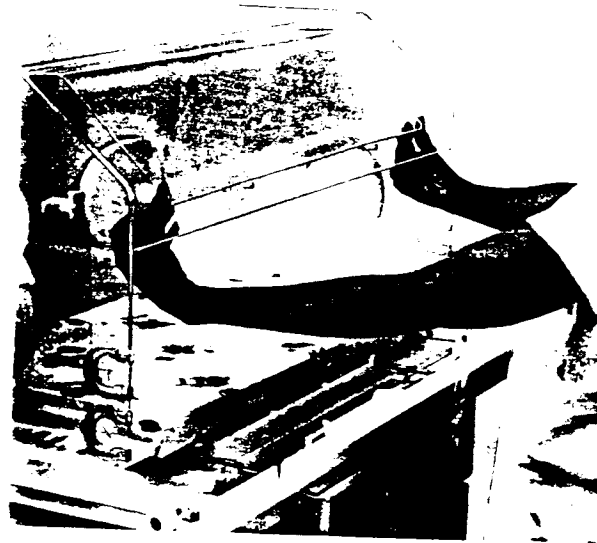

1. **RELEASE FRONT OF INNER WALL** by pushing back slightly to release the wall from the two stand-offs located on the front of the Hood.

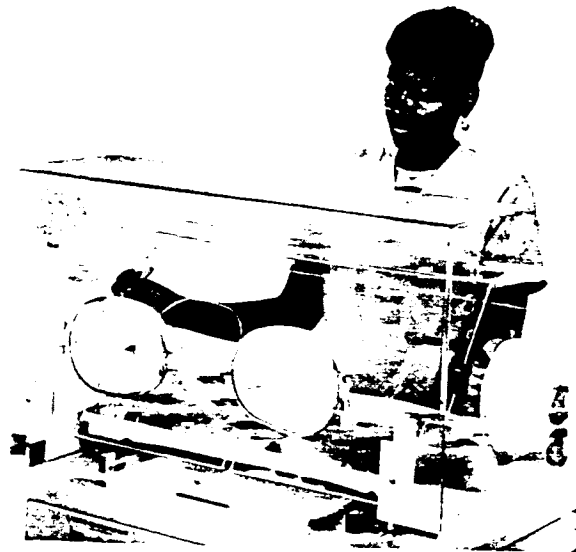

2. **REMOVE THE UPPER INNER WALL** by lowering it in the direction shown.

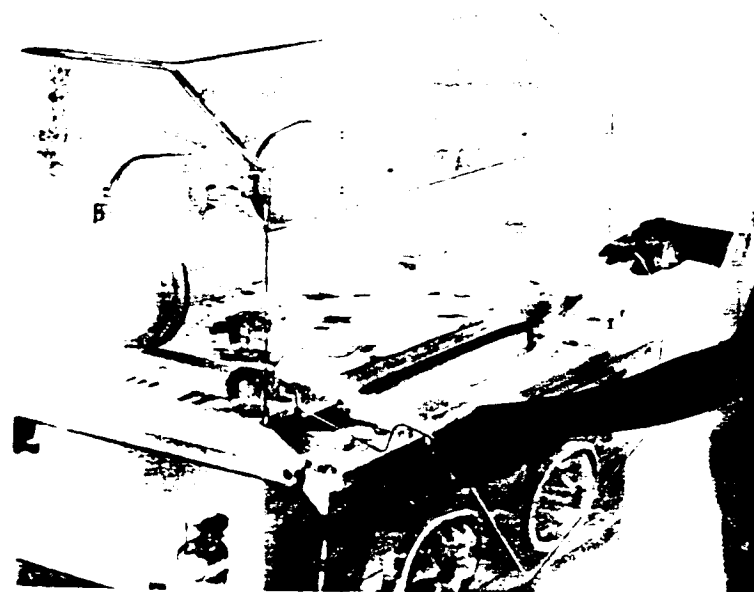

3. **REMOVE THE REAR INNER WALL** by first sliding out the Mattress Tray several inches. Raise the Inner Wall up to clear the key hole slots. Remove the wall from the Incubator.

FIGURE 4.4 REMOVAL OF INNER WALL – GROUP 2

- D. **REMOVE THE ACCESS PANEL INNER WALL (GROUP 1 ONLY).** With the Access Panel completely open, remove the Inner Wall by simultaneously pulling out at the top and pushing in the downward direction.
- E. **REMOVE MATTRESS TRAY.** Close the Access Panel and latch the Hood Assembly in the open position, then lift out the Mattress Tray. Remove and discard the disposable mattress cover.
- F. **REFER TO PARAGRAPH 2.4, STEP G ,** and raise and then lock the Hood in place.
- G. **REMOVE THE MAIN DECK (GROUP 1).** Rotate the Main Deck Retainer Figure 4.5 parallel with the slot, then lift out the Main Deck and Hood Seat Gasket.

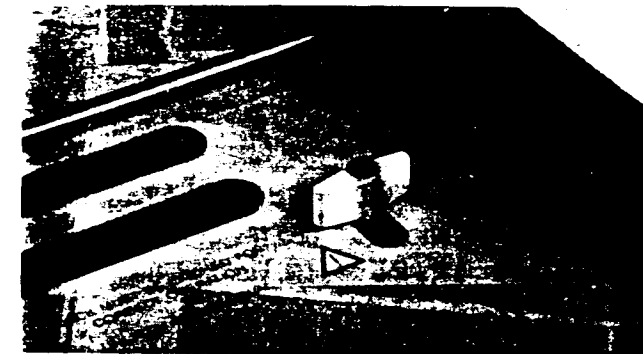

FIGURE 4.5 REMOVAL OF MAIN DECK – GROUP 1

F. **REMOVE MAIN DECK (GROUP 2).** Refer to Figure 4.6 and remove the Main Deck.



FIGURE 4.6 REMOVAL OF MAIN DECK – GROUP 2

G. REMOVE THE DECK PLATE (GROUP 2). Refer to Figure 4.7 and remove the Deck Plate.

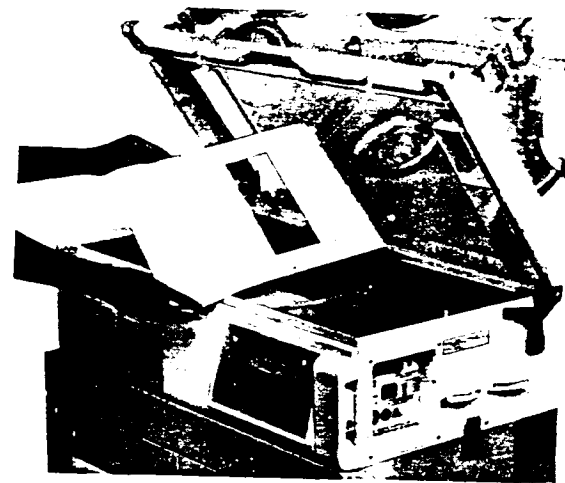

FIGURE 4.7 REMOVAL OF DECK PLATE GROUP

H. REMOVE AIR INTAKE TUBE. Grasp the Air Intake Tube (Figure 4.8), twist and pull it toward the front of the Incubator until the end of the tube clears the gasket. Remove the tube from the base assembly.



FIGURE 4.8 REMOVAL OF AIR INTAKE TUBE

- I. REMOVE DISPOSABLE ACCESS DOOR CUFF from each Access Door Gasket by pulling it off from the outside; discard the cuffs.
- J. REMOVE ACCESS DOOR GASKETS by pulling them free.
- K. REMOVE TUBING ACCESS GROMMETS from each side of the Hood by pulling them free.
- L. REMOVE DISPOSABLE IRIS ENTRY PORT SLEEVES by pulling each Sleeve off the retainer rings; discard the sleeves.
- M. REMOVE THE AIR INTAKE MICROFILTER COVER by loosening the two thumb screws.

4.2.2 CLEANING

CLEANING AGENTS. An iodophor or quaternary disinfectant detergent registered by the U.S. Environmental Protection Agency should be used, but only after the Incubator is empty and disassembled as described in paragraph 5. . A cleanser such as Air-Shields Kleenaseptic®-b Cleanser may be used. When using any cleaning agent, follow the manufacturer's directions for use. After removing all solid wastes and contaminants from the disassembled parts, clean them as follows:

SKIN PROBE (MODEL C450 QT). Use a disinfectant-detergent to thoroughly clean all surfaces, then dry with a clean cloth or paper towel.

HUMIDITY CHAMBER AND FILL PIPE, AIR INTAKE TUBE, ACCESS DOOR GASKETS, TUBING ACCESS GROMMETS. Fill the humidity chamber with a disinfectant-detergent, then remove the W-shaped Baffle from the chamber and dry it with a clean cloth or paper towel. Place the Air Intake Tube, Access Door Gaskets, Tubing Access Grommets into the solution.

NOTE: If necessary, a larger container may be used, but if the chamber is not used, then the Fill Pipe and Humidity Chamber must be cleaned separately.

Allow parts to soak as recommended by the cleaning solution's manufacturer, then remove them and dry completely with a clean cloth or paper towel. Drain the Humidity Chamber, scrub it thoroughly, including all indentations, then dry the chamber and Fill Pipe (inside and out) with a clean cloth or paper towel.

If it is necessary to remove the fill pipe for cleaning, rotate the Fill Pipe Assembly about 1/4 turn to the left. Loosen the thumb screw that secures the Fill Pipe Bracket, and rotate the bracket 1/4 turn to the left. Unscrew the Fill Pipe Assembly by rotating counterclockwise as shown in Figure 4.9. Clean the Fill Pipe Assembly and the sleeve that becomes a loose part when the Fill Pipe Assembly is unscrewed.



FIGURE 4.9 REMOVAL OF HUMIDITY FILL PIPE ASSEMBLY

CONTROLLER. The portions of the Controller external to the controlled Incubator environment include the front panel and the top, bottom, and two sides of the chassis. These portions may be wiped clean with a cloth dampened with a disinfectant-detergent.

The portions of the Controller that are within the controlled environment are on the rear surface; included are the air temperature probe, the fan impeller, the heater, the gaskets, and the surface of the Controller to which these components are mounted.

CAUTION: Failure to clean could result in sufficient lint build-up to reduce airflow, which will affect temperature control and cause high oxygen concentrations.

- 1. Remove any lint build-up; pay particular attention to the fan impeller, heater, air temperature probe, and air flow sensor.
- 2. Clean these surfaces with a disinfectant-detergent, then dry with a clean cloth or paper towel.

NOTE: A sterilizer tank is available as an accessory from Air-Shields to facilitate cleaning the rear surface of the Controller. The Controller rear surface is immersed into the tank after filling it with a disinfectant-detergent, then allowed to soak as recommended by the manufacturer of the cleaning solution.

MATTRESS TRAY AND DECK PLATE. Use a disinfectant-detergent to clean all surfaces thoroughly, then dry with a clean cloth or paper towel.

MATTRESS TILT CONTROL. REMOVE ALL SOLID WASTES and contaminants from the Mattress Tilt Control. An iodophor or quaternary disinfectant-detergent registered with the U.S. Environmental Protection Agency should be used to clean the mechanism. A cleanser such as Kleenaseptic®-b Cleanser may also be used. When using any cleaning agent, follow the manufacturer's directions for use.

WARNING: DO NOT lubricate the Mattress Tilt Mechanism with oil or other potentially flammable material in an oxygen-enriched environment.

HOOD AND CABINET STAND. Use a disinfectant-detergent to clean all surfaces of the hood thoroughly, including the inner wall and access door heat shield. Make sure to clean all holes, indentations, baffles, etc., then dry with a clean cloth or paper towel.

CAUTION:

- Alcohol can cause crazing of the clear Acrylic Hood. Do not use alcohol for cleaning.
- Do not expose the hood assembly to direct radiation from germicidal lamps. Ultraviolet radiation from these sources can cause cracking of gaskets, fading of paint, and crazing of the clear Acrylic Hood.

AIR INTAKE MICROFILTER. Do not attempt to clean or reverse the microfilter. If visibly dirty, or older than 3 months, it should be replaced. Before installing a new filter, clean the Microfilter Chamber and Cover with a disinfectant-detergent.

WARNING: A dirty Inlet filter may affect oxygen concentration and/or cause carbon dioxide build-up. Be sure the filter is checked on a routine basis commensurate with local conditions.

IMPORTANT: Specific Assemblies (Inner Walls, Main Deck, Mattress Tilt Mechanisms, Oval Gaskets) are not interchangeable between the C100/C200, C500/550 and the C400/C450 Incubators. Verify proper identification of components prior to assembly.

After cleaning all parts and assemblies as described in Paragraph 5. , reassemble as described below.

- INSTALL THE AIR INTAKE TUBE** (into the Base Assembly) by reversing the procedure shown in Figure 5.6.
- INSERT HUMIDITY CHAMBER BAFFLE** into the Humidity Chamber.

- INSTALL THE MAIN DECK AND HOOD SEAT GASKET (GROUP 1)** into the Base Assembly as shown in Figure 4.10. Rotate the Main Deck Retainer Knob to secure the deck.

WRONG MAIN DECK POSITION-
Main Deck placed up on gasket on one side, permitting air flow as shown by dashed line.

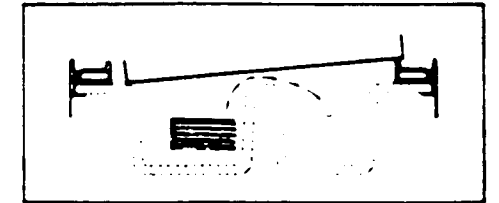

CORRECT MAIN DECK POSITION-
Main Deck placed down on conditioning chamber top.

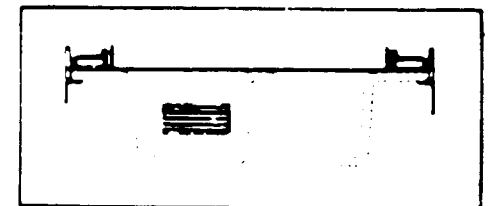

FIGURE 4.10 INSTALLATION OF MAIN DECK AND HOOD SEAT GASKET (GROUP 1)

- INSTALL THE DECK PLATE (GROUP 2).** Refer to Figures 4.6, 4.7 and 4.11 and install the Deck Plate. Make sure the Deck Plate is properly aligned on its Key Pins.

CAUTION: For proper operation, the Deck Plate* must be installed.

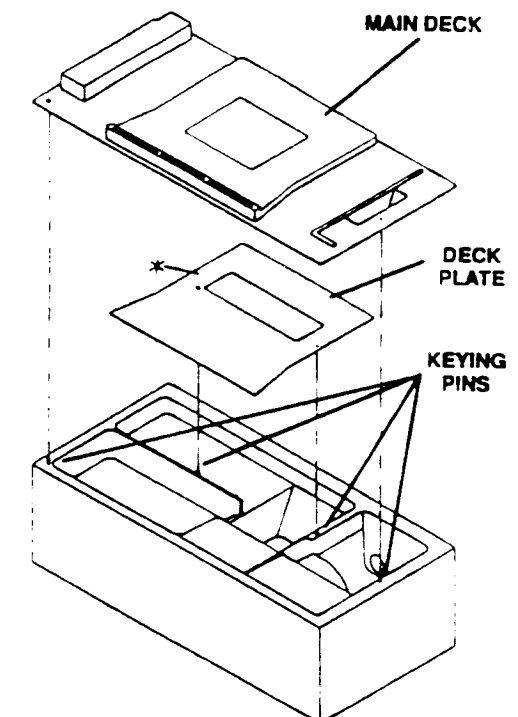

FIGURE 4.11 INSTALLATION OF DECK PLATE AND MAIN DECK

D. **INSTALL THE MATTRESS TILT MECHANISMS** on the Main Deck. (Refer to Figure 5. .)

NOTE: There is a right-hand and left-hand tilt mechanism.

CAUTION: Be sure the two thumb screws that hold the tilt mechanisms to the deck are tightened securely.

E. **INSTALL THE MATTRESS TRAY.**

Install the Mattress Tray by positioning it a few inches above the mattress rails, then lowering it straight down.

F. **INSTALL DISPOSABLE MATTRESS COVER.** Place a new disposable Mattress cover over the mattress, then place the mattress onto the tray.

G. **INSTALL DISPOSABLE IRIS ENTRY PORT SLEEVES.** Install a new Iris Entry Port Sleeve as shown in Figure 4.12.

NOTE: If the Incubator is to be gas sterilized, wait until after sterilization to install new sleeves.

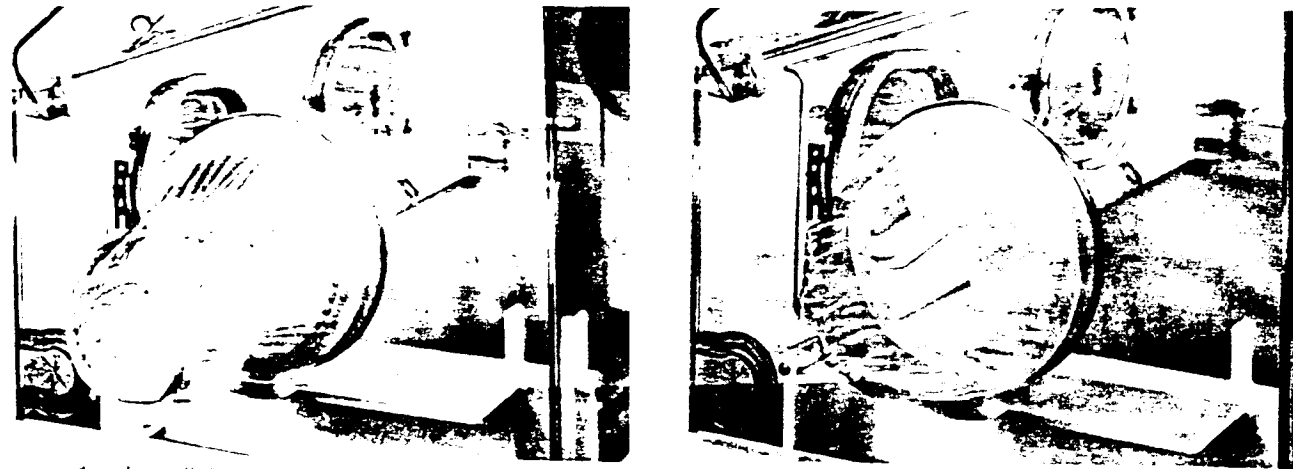

1. Install the smaller diameter elastic band of a new sleeve over the inner ring of the port housing.

2. Fold back and slip elastic band over the outer ring of the port housing.

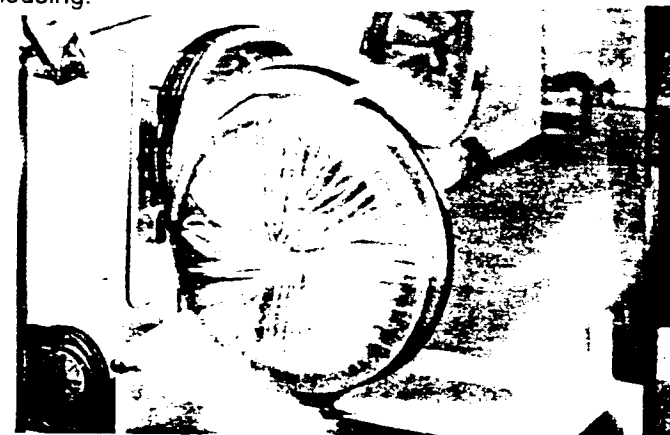

3. Rotate outer ring to close. If properly installed, the sleeve will open again if rotation is reversed.

FIGURE 4.12 INSTALLATION OF IRIS ENTRY PORT SLEEVE

H. **INSTALL A TUBING ACCESS GROMMET** into the front edge of each side of the Hood. Replace if distorted or torn.

I. **INSTALL AN ACCESS DOOR GASKET** behind each Access Door, as shown in Figure 4.13.

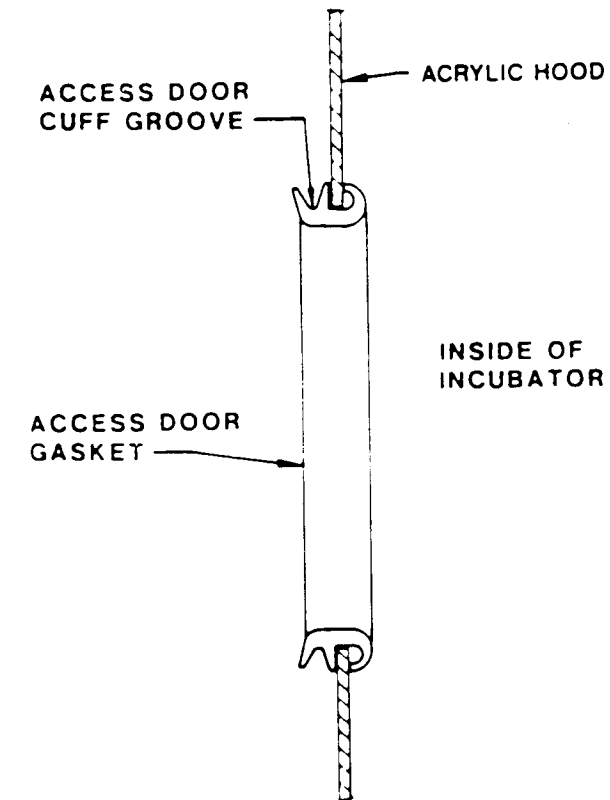

FIGURE 4.13 INSTALLATION OF ACCESS DOOR GASKET

J. **INSTALL A NEW ACCESS DOOR CUFF** onto each Access Door Gasket by stretching the larger diameter elastic band into the groove in the gasket. When installed correctly, the cuff has a small opening at its center. The Access Door should latch with slight pressure and should open when the latch lever is depressed.

NOTE: If the Incubator is to be gas sterilized, wait until after sterilization to install new cuffs.

K. **INSTALL HOOD INNER WALL** by reversing the procedure shown in Figure 5. .

L. **INSTALL A NEW AIR INTAKE MICROFILTER** if necessary. Replace the Air Intake Microfilter Cover and tighten the two thumb screws. If a new filter is installed, indicate the date on the place provided on the cover.

M. **CHECK THAT INCUBATOR IS SECURELY CLAMPED TO STAND.** The Locking Bar should be approximately horizontal when locking bar is released and clamp is engaged in retainer on Incubator.

IMPORTANT: A complete Functional Checkout (paragraph 2.) should be performed before returning the unit to service.

4.3 GAS STERILIZATION

Prior to gas sterilization, the entire Incubator should be thoroughly cleaned as described elsewhere in this section. All used disposable elements such as iris sleeves, access door cuffs, mattress, etc., should be

removed and discarded as described in the cleaning instructions. New disposable elements should be installed after sterilization.

Release the Controller latches and slide the unit out about 1/4". The Access Panel may be closed, but the Access Doors should be left open. The Air Intake Microfilter may be left in place.

CAUTION: Sterilization temperature should not exceed 130 °F (54.5 °C).

NOTE: Gas sterilization does not eliminate the need for routine replacement of the Air Intake Microfilter.

Standard Gas sterilization procedures as programmed by automatic equipment such as made by American Sterilizer and Wilmot Castle are satisfactory as these do not normally exceed 130 °F (54.5 °C).

Upon completion of gas sterilization, an aeration period of 16 to 24 hours should be allowed. The Controller should be properly secured in place and the Incubator should be operated in a dry condition for the entire period of aeration at a temperature of 32 to 35 °C. After aeration, if the unit is not to be used immediately, a disposable dust cover should be placed on the Incubator.

IMPORTANT: A complete Functional Checkout Procedure (paragraph 2.4) should be performed before returning the unit to service.

SECTION 5 SERVICE

5.1 GENERAL

This section provides calibration procedures, troubleshooting procedures and removal and replacement procedures.

5.2 CONTROLLER AND INCUBATOR FUNCTIONAL TESTS

5.2.1 GENERAL

This paragraph provides off line diagnostic tests and a leakage current test for the Controllers. In addition, it provides an oxygen concentration test for the Incubator.

5.2.2 TEST EQUIPMENT REQUIRED

The test equipment listed below is required for performing the Controller and Incubator Functional Tests. Equivalent test equipment may be substituted.

- Probe Simulator, Part Number
- Digital VOM, Fluke Model 8060A
- Variable Transformer 0 to 300 Vac, 5A with voltage and current meters.
- Adapter Cable Part Number
- Remote Alarm Module Part Number 68 414 70 (Required only if Incubator is normally equipped with a Remote Alarm Module).
- Leakage Current Tester, Bio-Tek 501
- Flow Meter, Victor Model 1099-0025

5.2.3 CONTROLLER OFF-LINE DIAGNOSTIC TESTS

A. INVOKING THE OFF-LINE DIAGNOSTICS

1. Refer to Paragraph 5.5 and remove the Controller from the Incubator. Connect the Controller to a primary source of correct voltage and frequency.

NOTE: C400 Controllers Only – Remove the Main Board from the Front Panel.

2. Turn the Controller off. Simultaneously press and hold the UP and DOWN arrow Keys on the Front Panel and turn on the Power Switch.
3. Hold the UP and DOWN arrow Key until the **Set Temp °C**, **Baby Temperature °C**, and **Air Temperature °C**, displays all "U" s. Release the UP and DOWN Arrow Keys, after a few seconds, the Controller will enter the Off Line Diagnostic Mode.

B. CONTROL AND DISPLAY FUNCTIONS

1. During Off-Line Diagnostics, the **Set Temp °C** Display will flash and display the current Test Number.
Example: Test Number 1 will be displayed as 00.1.
Test Number 23 will be displayed as 02.3.
2. During Off-Line Diagnostics, the UP and DOWN Arrow Keys are used to select the desired test.

C. TEST NUMBER 1 – SOFTWARE VERSION

1. Use the UP or DOWN Arrow Key to select Test Number 1.
2. The **Baby Temperature** °C will display the software version, typically 01.25 or higher.

D. TEST NUMBER 2 – ROM CHECK SUM

1. Use the UP or DOWN Arrow Key to select Test Number 2.
2. The **Baby Temperature** °C display will display the ROM hexadecimal check sum, for example 92.AE.

E. TEST NUMBER 3 – AUDIO ALARM AND LED TEST

1. Use the UP or DOWN Arrow Key to select Test Number 3.
2. The **Keypad Lock** and all **Alarm Indicators** will light steady on. The **Set Temp** °C, **Baby Temperature** °C, and **Air Temperature** °C Displays will show all eights.

*NOTE: The **Set Temp** °C Display will show all eights instead of the Test Number.*

3. Press the **Silence/Reset** Key. The Power Fail Indicator will go off and the audible alarm will sound. Press the **Silence/Reset** Key to cancel the alarm.
4. If the Incubator is normally used with a Remote Alarm Module, connect the RAM cable to the AUXILIARY PORT on the Side Panel. Press the **Silence/Reset** Key. The RAM will produce an audible alarm and the Controller will remain silent.

F. TEST NUMBER 4 – KEYPAD TEST

1. Use the UP or DOWN Arrow Key to select Test Number 4.
2. Press the **Keypad Lock** Key, the first digit of the **Baby Temperature** °C Display will change from 0 to 1 when the key is pressed.
3. Press the **>37°C** Key, the third digit of the **Baby Temperature** °C Display will change from 0 to 1 when the key is pressed.
4. Press the **Baby Mode Control (C450 Controllers only)** Key, the fourth digit of the **Baby Temperature** °C Display will change from 0 to 1 when the key is pressed.
5. Press the **Air Mode Control (C450 Controllers only)** Key, the first digit of the of the **Air Temperature** °C Display will change from 0 to 1 when the key is pressed.
6. Press the **Silence/Reset** Key, the third digit of the of the **Air Temperature** °C Display will change from 0 to 1 when the key is pressed.

G. TEST NUMBER 6 – AC MAINS CORRECTION FACTOR

1. For this test the Controller must be connected to a primary source of correct voltage and frequency through a variable transformer of the type described in Paragraph 5.2.2 above.
2. Use the UP or DOWN Arrow Key to select Test Number 6.
3. Set the variac to 120 Vac. The **Baby Temperature** °C display will read 1.00.
4. Set the variac to 108 Vac. The **Baby Temperature** °C display will read 1.20.
5. Set the variac to 132 Vac. The **Baby Temperature** °C display will read 0.80.
6. Set the variac to 120 Vac.

NOTE: Test Number 5 is part of the calibration procedure. Refer to Paragraph 5.3 if the Test Number 6 results are not obtained.

H. TEST NUMBER 9 – SKIN CHANNEL TEST (C450 CONTROLLERS ONLY)

1. Use the UP or DOWN Arrow Key to select Test Number 9.
- NOTE: Test Numbers 7 and 8 have been reserved for future use.*
2. Connect the simulator to the PATIENT PROBE Connector on the Side Panel.
 3. Set the Simulator to SKIN and 20 °C. The **Baby Temperature** °C Display will read 20.00 ± 0.08 °C.
 4. Set the Simulator to SKIN and 40 °C. The **Baby Temperature** °C Display will read 40.00 ± 0.08 °C.
 5. Press the **Silence/Reset** Key. The **Baby Temperature** °C Display will read 36.00 ± 0.08 °C. The **Air Temperature** °C Display will read CAL.

I. TEST NUMBER 10 – CALIBRATION CHANNEL (C450 CONTROLLERS ONLY)

1. Use the UP or DOWN Arrow Key to select Test Number 10.
2. The **Baby Temperature** °C Display will read 35.89 ± 0.04 °C.

J. TEST NUMBER 11 – AIR FLOW STATUS

1. Use the UP or DOWN Arrow Key to select Test Number 11.
2. The **Baby Temperature** °C Display will read AF.1. The **Air Temperature** °C Display will display Pr.b.

K. TEST NUMBER 12 – HEATER SAFETY AND SOLID STATE RELAY TEST

1. Use the UP or DOWN Arrow Key to select Test Number 12.
- CAUTION: During this test the Heater will be turned on and off.*
2. Verify that the current drawn by the Controller is less than 1 Amp.
 3. The **Baby Temperature** °C Display will read 0F.F. The **Air Temperature** °C Display will display 00.0.
 4. Press the **Silence/Reset** Key twice. The **Air Temperature** °C Display will display 02.0.
 5. Press the **>37°** Key. The **Baby Temperature** °C Display will read Ht.r. The Controller will draw short pulses of current > 1 Amp.
 6. Press the **>37°** Key. The **Baby Temperature** °C Display will read OFF and the short current pulses will cease.
 7. Press the **Silence/Reset** Key to increment the the **Air Temperature** °C Display to 10.0.
 8. Press the **>37°** Key. The **Baby Temperature** °C Display will read Ht.r and there are no current pulses.

L. TEST NUMBER 13 – EPROM TEST

1. Use the UP or DOWN Arrow Key to select Test Number 13.
2. The **Baby Temperature** °C Display will read 00.01, 00.02 or 00.08.

M. TEST NUMBER 14 – BATTERY CHARGER TEST

1. Use the UP or DOWN Arrow Key to select Test Number 14.
2. During this test the **Baby Temperature** °C Display shows the battery voltage, typically 8.40 to 9.80. The **Air Temperature** °C Display will show either CHG or OFF.

3. To turn on the battery charger, press the **Silence/Reset** Key. The **Air Temperature °C** Display will show CH.G. When the charger is on, the battery voltage should be 0.5 to 1 Volt higher compared to the off condition.

N. TEST NUMBER 15– EXTERNAL A/D, CHANNEL 0 VOLT TEST

1. Use the UP or DOWN Arrow Key to select Test Number 15.
2. The **Baby Temperature °C** Display will read from 00.00 to 00.02.

O. TEST NUMBER 16 – EXTERNAL A/D, CHANNEL 5 VOLT TEST

1. Use the UP or DOWN Arrow Key to select Test Number 16.
2. The **Baby Temperature °C** Display will read 1F.FF.

P. TEST NUMBER 17 – DYNAMIC LED TEST

1. Use the UP or DOWN Arrow Key to select Test Number 17.

NOTE: Do to the nature of the test, the **Set Temp °C** Display will not show the Test Number.

2. The Controller LEDs will be tested in succession as follows:
 - The **Keypad Lock** Indicator. **Note:** the **Keypad Lock** indicator will remain on until the last **Alarm** Indicator is tested.
 - The 6 **Alarm** Indicators.
 - The 5 segments of the **Heater Power %** Indicator.
 - Each digit of the **Set Temp °C** Display will be cycled from 0 to 9 in succession. The **>37°** Indicator will remain on during the **Set Temp °C** Display test.
 - Each digit of the **Baby Temperature °C** Display will be cycled from 0 to 9 in succession. The **Baby Temperature** Indicator will remain on during the **Baby Temperature °C** Display test.
 - Each digit of the **Air Temperature °C** Display will be cycled from 0 to 9 in succession. The **Air Temperature** Indicator will remain on during the **Air Temperature °C** Display test.

Q. TEST NUMBER 18 – AIR PROBE CONTROL CHANNEL TEST

1. Use the UP or DOWN Arrow Key to select Test Number 18.
2. Connect the simulator to the AUXILIARY AIR PROBE connector on the Side Panel. Set the simulator to AIR and OPEN. The **Baby Temperature °C** Display will display O.P.
3. Set the simulator to AIR and 20 °C. The **Baby Temperature °C** Display will display 20.00 ± 0.08 °C.
3. Set the simulator to AIR and 36 °C. The **Baby Temperature °C** Display will display 36.00 ± 0.08 °C.
4. Set the simulator to AIR and 40 °C. The **Baby Temperature °C** Display will display 40.00 ± 0.08 °C.
5. Set the simulator to AIR and SHORT. The **Baby Temperature °C** Display will display S.H.

S. TEST NUMBER 19 – AIR PROBE MONITOR CHANNEL TEST

1. Use the UP or DOWN Arrow Key to select Test Number 19.
2. Connect the simulator to the AUXILIARY AIR PROBE connector on the Side Panel. Set the simulator to AIR and OPEN. The **Baby Temperature °C** Display will display O.P.
3. Set the simulator to AIR and 20 °C. The **Baby Temperature °C** Display will display 20.00 ± 0.08 °C.
3. Set the simulator to AIR and 36 °C. The **Baby Temperature °C** Display will display 36.00 ± 0.08 °C.
4. Set the simulator to AIR and 40 °C. The **Baby Temperature °C** Display will display 40.00 ± 0.08 °C.
5. Set the simulator to AIR and SHORT. The **Baby Temperature °C** Display will display S.H.

T. TEST NUMBERS 20 THROUGH 27– AIR PROBE MONITOR CHANNEL TEST

Tests 20 through 27 show the internal A/D converter readings. The results are shown on the **Baby Temperature °C** Display; they range from 00.00 to greater than 32.91.

1. Use the UP or DOWN Arrow Key to select Test Number 20 (Channel 0). The **Baby Temperature °C** Display will display 25.00 ± 03.00
2. Use the UP or DOWN Arrow Key to select Test Number 21 (Channel 1). The **Baby Temperature °C** Display will display 25.00 ± 03.00 .
3. Use the UP or DOWN Arrow Key to select Test Number 22 (Channel 2). The **Baby Temperature °C** Display will display 25.00 ± 03.00 .
4. Test Number 23. This test is not valid indication – the test has been assigned to future use.
5. Use the UP or DOWN Arrow Key to select Test Number 24 (Channel 4). The **Baby Temperature °C** Display will display 40.00 ± 02.00 .
6. Use the UP or DOWN Arrow Key to select Test Number 25 (Channel 5). The **Baby Temperature °C** Display will display greater than 32.91.
7. Use the UP or DOWN Arrow Key to select Test Number 26 (Channel 6). The **Baby Temperature °C** Display will display greater than 25.80.
8. Use the UP or DOWN Arrow Key to select Test Number 27 (Channel 7). The **Baby Temperature °C** Display will display 00.00 ± 00.40 .

5.2.4 LEAKAGE CURRENT TESTS**TEST SET-UP**

1. Connect the Controller to the primary power source through an ungrounded adapter plug, so that the unit is ungrounded. Turn the POWER switch on.
2. The leakage current test standards provided in the procedure below assume leakage through a resistance of 1000 Ohms. If the Leakage Tester being used does not provide this resistance, the test set-up must be adjusted to provide it.

PROCEDURE

1. Use the Leakage Current Tester to measure between the chassis of the unit under test and a known ground such as the ground connection of a wall receptacle. The leakage current must not exceed 100 micro-amps in 120 Vac Units or 500 micro-amps in 220/240 Vac Units.

2. Reverse the plug and repeat Step 1.
3. Perform Steps 1 and 2 with the Controller POWER switch OFF.

5.2.5 OXYGEN CONCENTRATION TESTS

Note: This test is applicable only to units that do not have an Oxygen or Saturation Controller attached to the Filter Cover.

TEST-SETUP

1. Place a calibrated oxygen analyzer on the mattress in the Incubator.
2. Apply oxygen at a flow rate of 8 LPM to the O₂ nipple on the Filter Cover.

PROCEDURE

1. Turn the unit ON.
2. After 40 minutes of operation, verify that the oxygen concentration level is between 37% and 48%.
3. Increase the Oxygen flow to 12 LPM. After another 40 minutes of operation, verify that the oxygen concentration level is between 65% and 95%.

5.3 CALIBRATION PROCEDURES

This paragraph provides calibration procedures for the Controllers. The equipment should be completely calibrated at least annually and after any repair. Unless otherwise indicated, all calibration procedures are performed under the following conditions:

- The Controller is connected to a primary source of the correct voltage and frequency.
- The Controller Front Panel has been removed from the chassis but is still connected electrically.

5.3.1 TEST EQUIPMENT REQUIRED

The test equipment listed below is required for performing the Main Board Calibration. Equivalent test equipment may be substituted:

- Digital VOM, Fluke Model 8060A
- Front End Test Plug Air-Shields Part Number
- Hardware High Temp Test Plug No. 1 Air-Shields Part Number
- Hardware High Temp Test Plug No. 2 Air-Shields Part Number
- Hardware High Temp Test Plug No. 3 Air-Shields Part Number

Alternatively, a precision decade box and matching connector may be substituted for the Front End and High Temp Test Plugs. Refer to Paragraph 5.6 for wiring diagrams and part numbers of mating connectors.

5.3.2 POWER SUPPLY (REFER TO FIGURES 5.1 AND 5.2 FOR LOCATION OF TEST POINTS AND ADJUSTMENTS).

SET-UP

Connect the DVM between TP3 and TP8 (GND) on the Main Board.

PROCEDURE

1. Adjust RT1 on the Power Supply Board for a reading of 4.00 ± 0.010 Vdc.

5.3.3 MAIN BOARD (REFER TO FIGURE 5.2 FOR LOCATION OF TEST POINTS AND ADJUSTMENTS).

SET-UP

Refer to Paragraph 5.2.3, Steps A and B, to invoke the Off-Line Diagnostics and select Diagnostic Test Number 9.

Connect the Front End Test Plug (Decade resistance value – 4320 Ohms) to the PATIENT PROBE Connector on the Side Panel.

PROCEDURE

1. Adjust RT1 until the the **Baby Temperature** °C Display reads 35.89 ± 0.03 °C.
2. Remove the Front End Test Plug. Connect the Hardware High Temp Test Plug No. 1 (Decade resistance value – 3729 Ohms) to J1 on the Probe Board.

3. Select Diagnostic Test Number 5. Press the >37° Key. Turn RT2 fully clockwise. Make sure the >37° Indicator is on and verify that:
 - The **Baby Temperature** °C Display reads 39.50 ± 0.03 °C.
 - The **Air Temperature** °C Display reads --.
 - The **High Temp** Alarm Indicator is Off.
 - The **Keypad Lock** Indicator is On.
4. Adjust RT2 counterclockwise until:
 - The **Air Temperature** °C Display reads --.H.
 - The **High Temp** Alarm Indicator is On.
5. Remove the High Temp Test Plug No. 1 and connect the High temp Test Plug No. 2 (Decade resistance value - 3805 Ohms) to J1 on the Probe Board. Verify that:
 - The **Baby Temperature** °C Display reads 39.00 ± 0.04 °C.
 - The **Air Temperature** °C Display reads --.
 - The **High Temp** Alarm Indicator is Off.
6. Remove the High Temp Test Plug No. 2 and connect the High temp Test Plug No. 3 (Decade resistance value - 0 Ohms) to J1 on the Probe Board. Verify that:
 - The **Air Temperature** °C Display reads S.H.

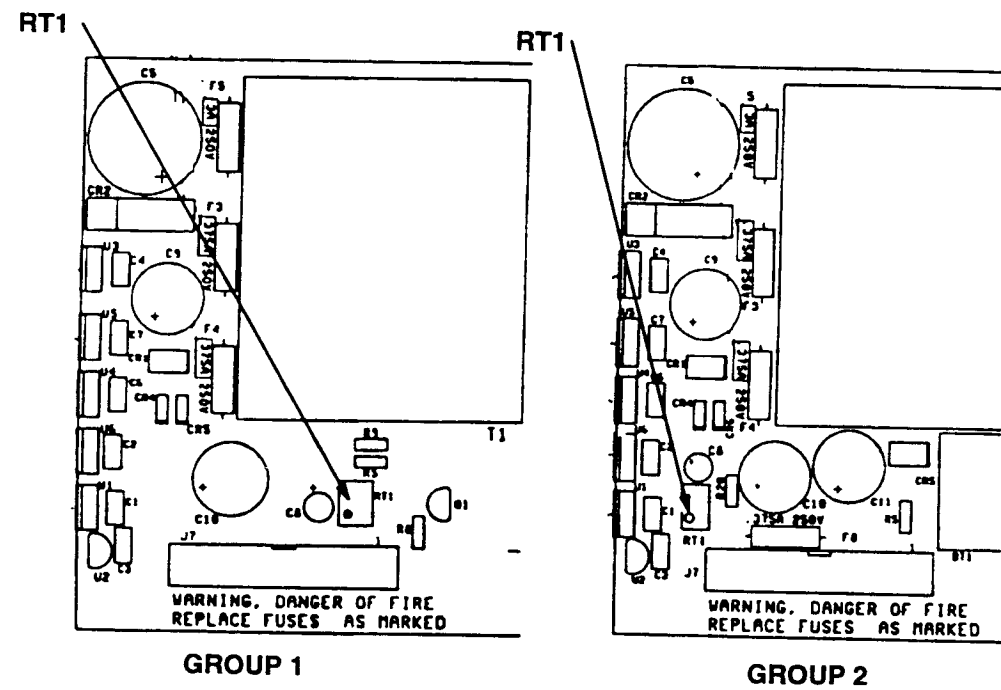

FIGURE 5.1 POWER SUPPLY LOCATION OF TEST POINTS AND ADJUSTMENTS

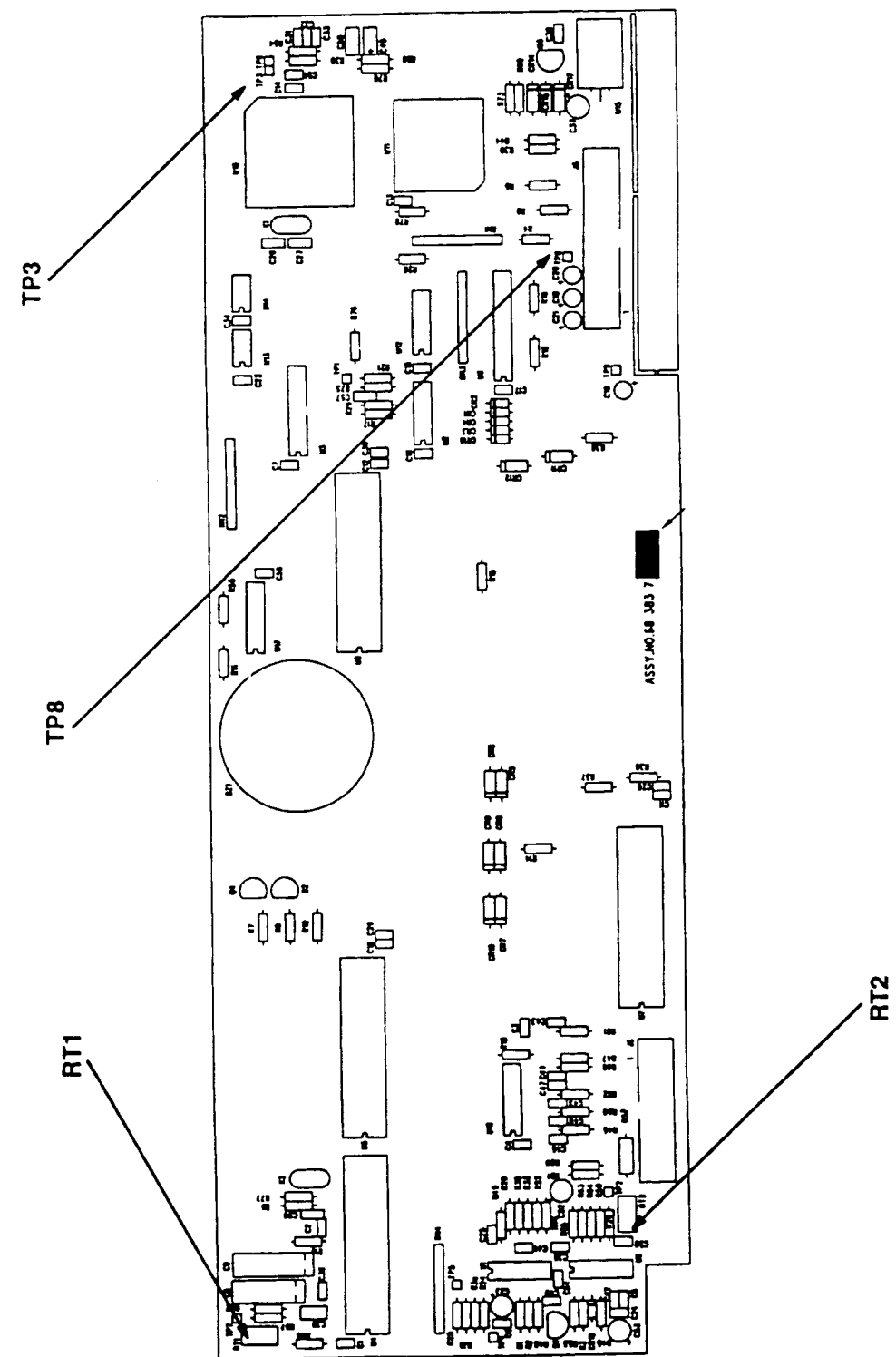

FIGURE 5.2 MAIN BOARD LOCATION OF TEST POINTS AND ADJUSTMENTS

5.4 TROUBLESHOOTING PROCEDURES

5.4.1 GENERAL

Troubleshooting guides for the Controller are provided in Paragraph 5.4.3 in the form of flowcharts. It is assumed that an attempt to calibrate has been made and all cables are in good condition.

5.4.2 TEST EQUIPMENT REQUIRED

The test equipment listed below is required for troubleshooting the Controller. Equivalent test equipment may be substituted.

- Digital VOM, Fluke Model 8060A
- Variable transformer 0 to 300 Vac, 5A with voltage and current meters.
- Hardware High Temp Test Plug No. 1 Air-Shields Part Number
- Hardware High Temp Test Plug No. 3 Air-Shields Part Number

5.4.3 POWER SUPPLY BOARD.

Refer to Paragraph 5. and remove the Controller from the Incubator.

Remove the Power Supply Board from the Controller but still maintain electrical connection. The following charts are intended for use with the theory of operation (Section 3) and the schematic diagrams (Section 7).

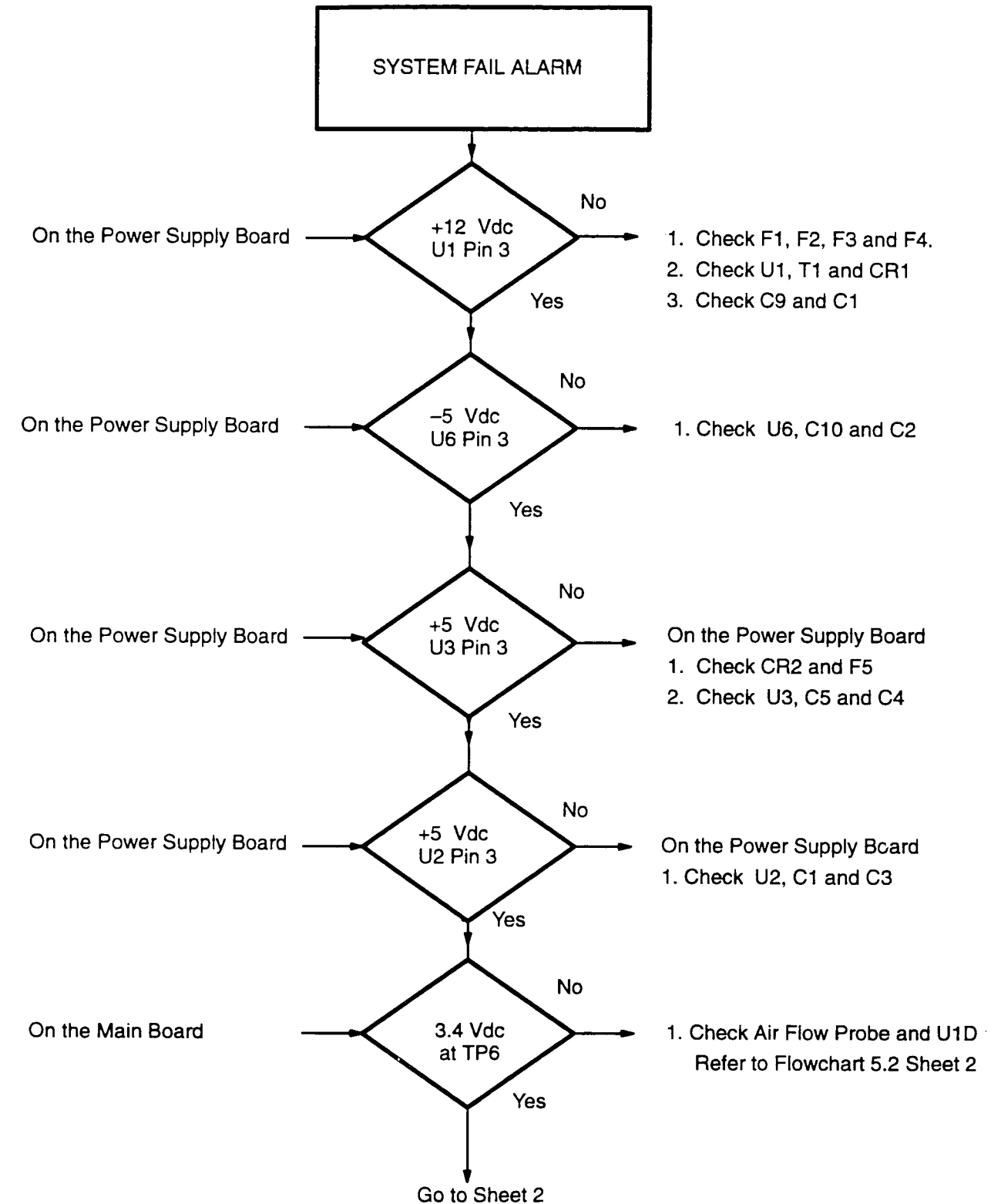

FLOWCHART 5.1 SYSTEM FAIL ALARM TROUBLESHOOTING (Sheet 1 of 2)

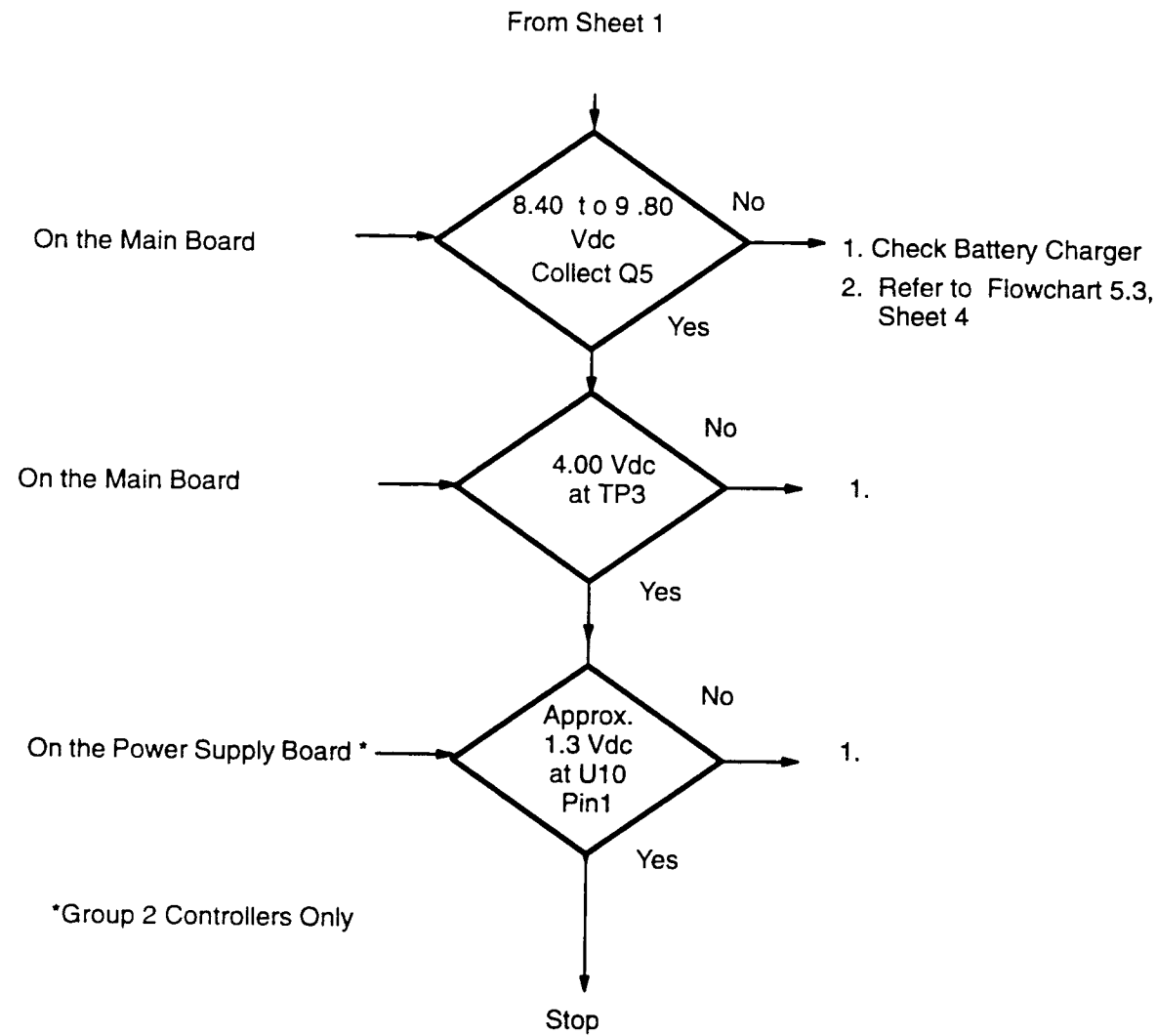

FLOWCHART 5.1 SYSTEM FAIL ALARM TROUBLESHOOTING (Sheet 2 of 2)

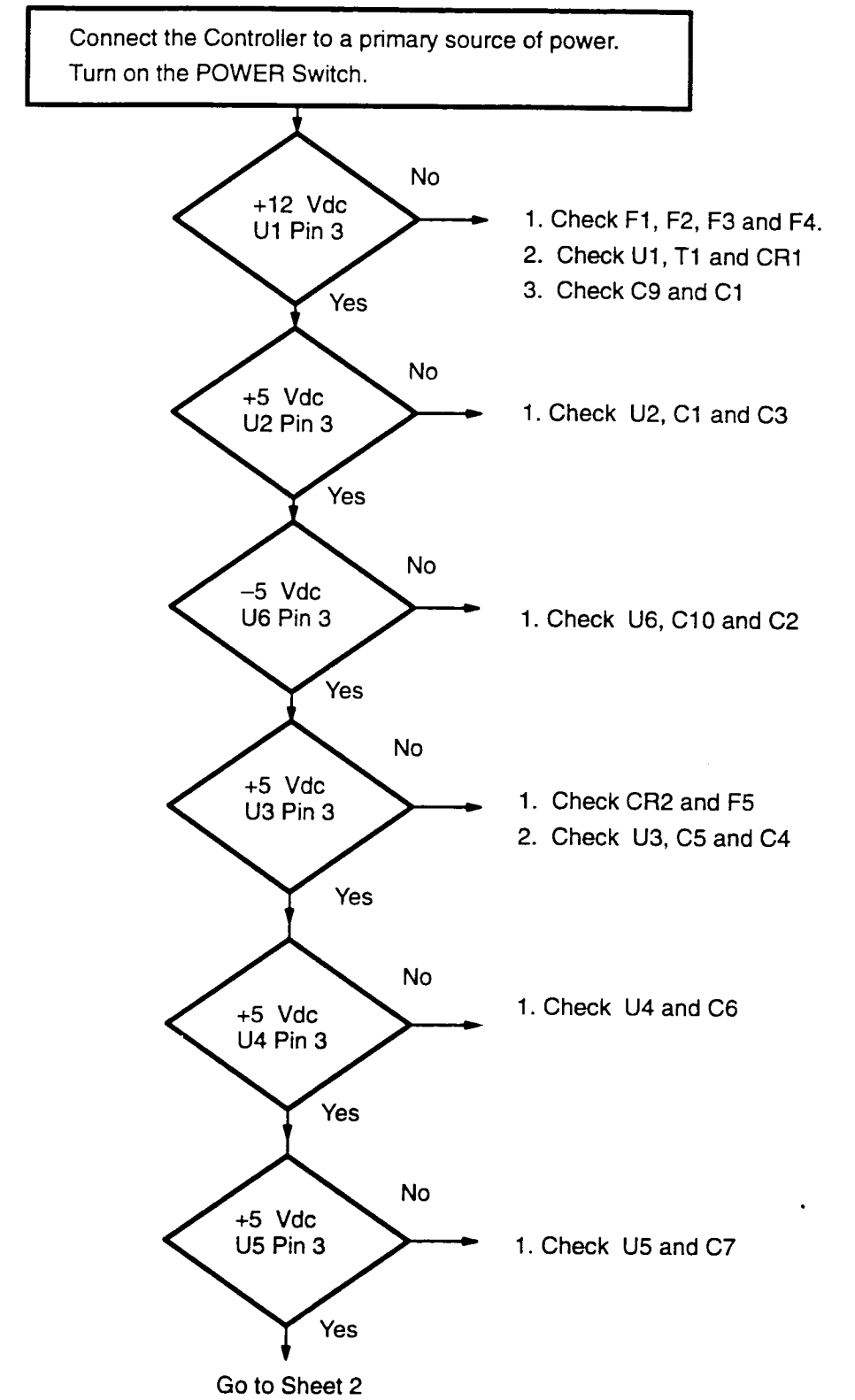

FLOWCHART 5.2 POWER SUPPLY BOARD TROUBLESHOOTING (Sheet 1 of 3)

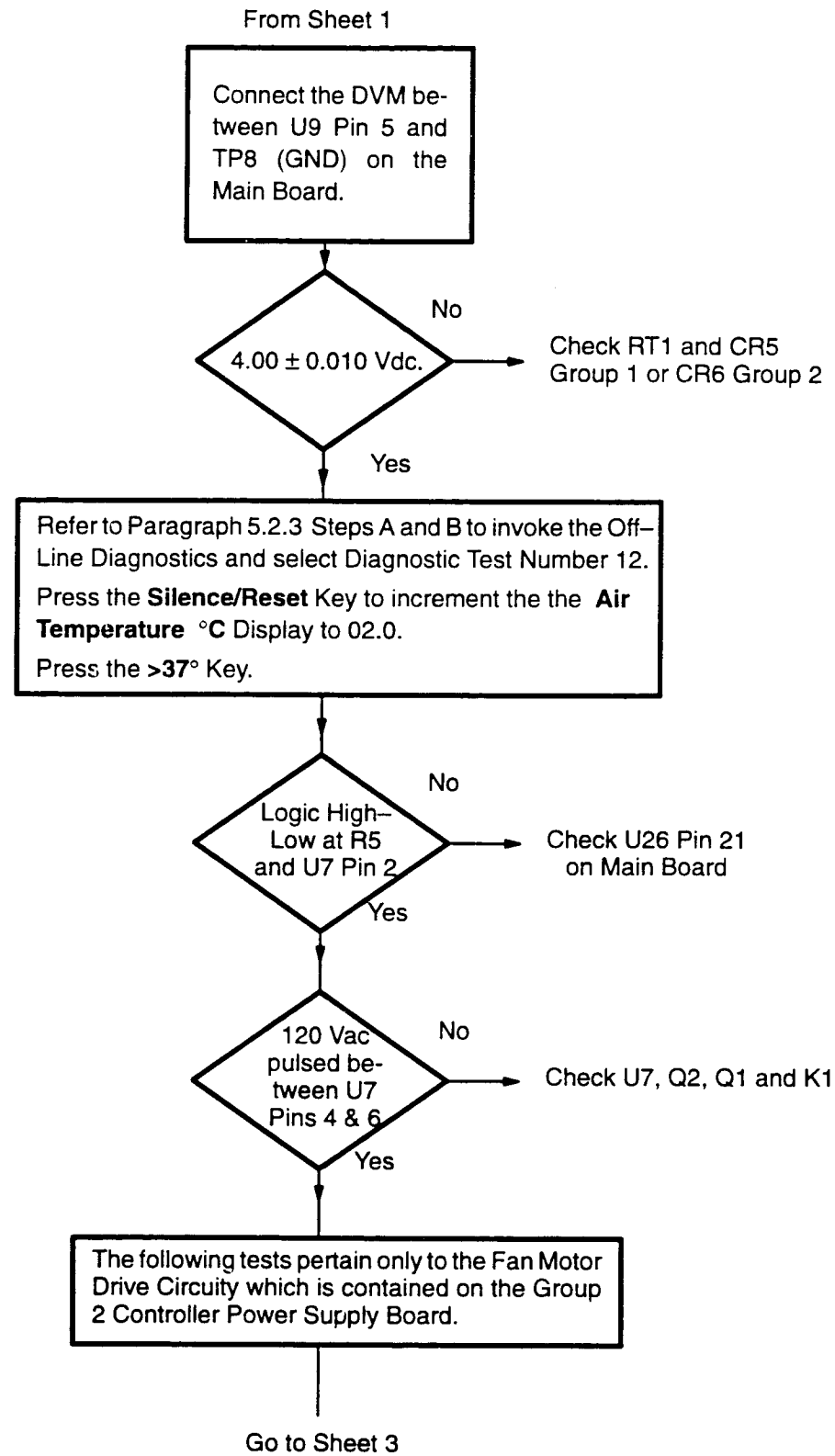

FLOWCHART 5.2 POWER SUPPLY BOARD TROUBLESHOOTING (Sheet 2 of 3)

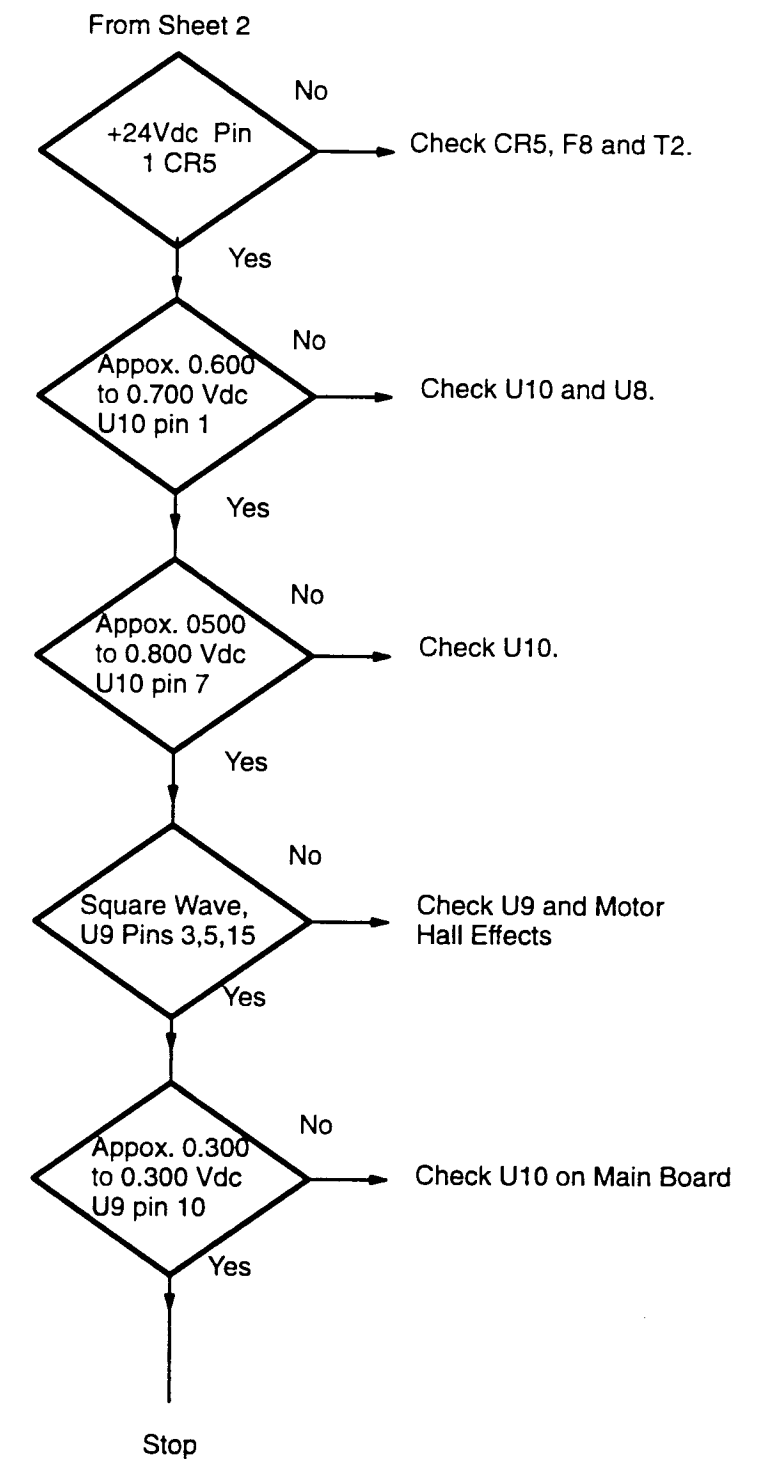

FLOWCHART 5.2 POWER SUPPLY BOARD TROUBLESHOOTING (Sheet 3 of 3)

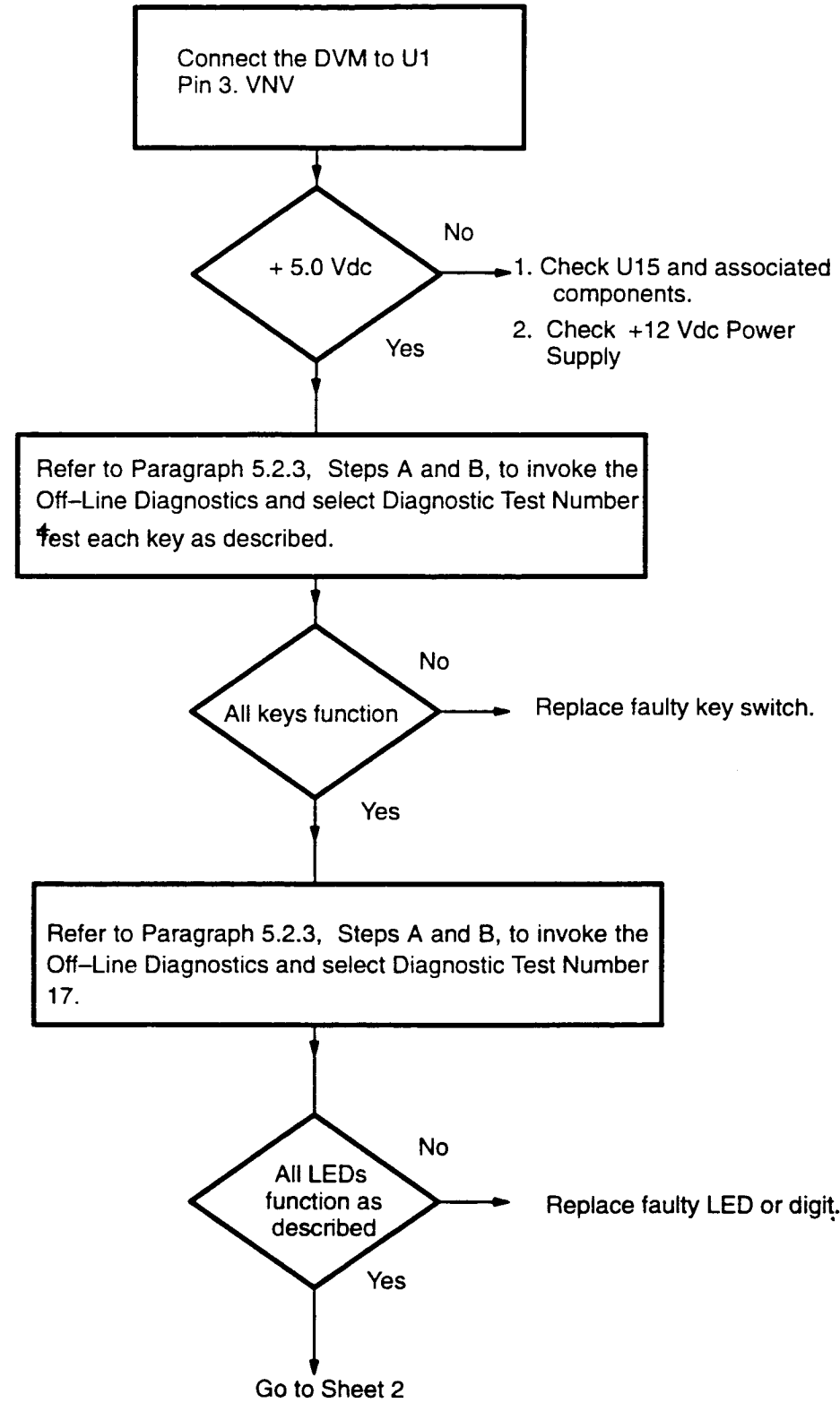

FLOWCHART 5.3 MAIN BOARD TROUBLESHOOTING (Sheet 1 of 2)

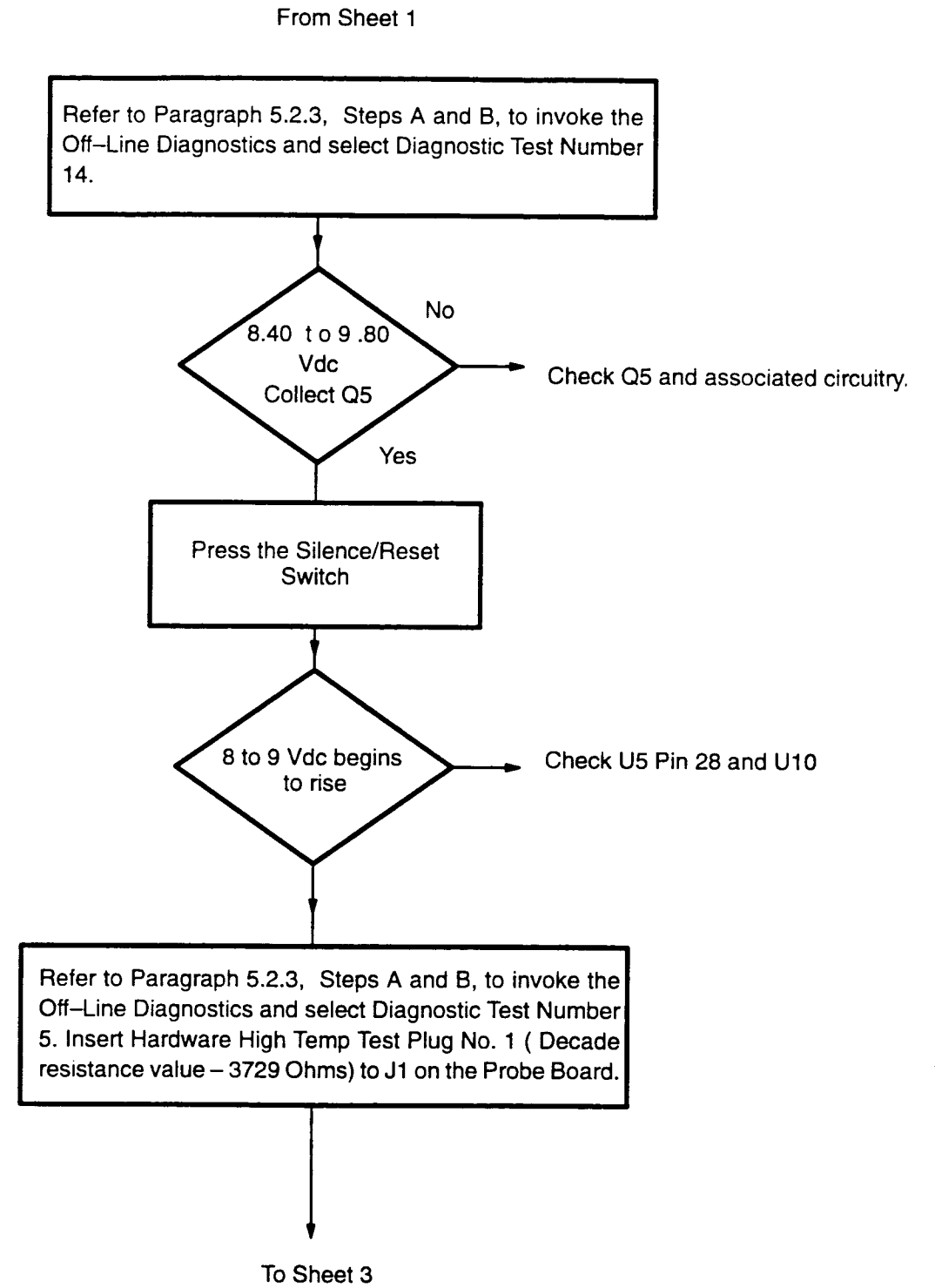

FLOWCHART 5.2 MAIN BOARD TROUBLESHOOTING (Sheet 2 of 2)

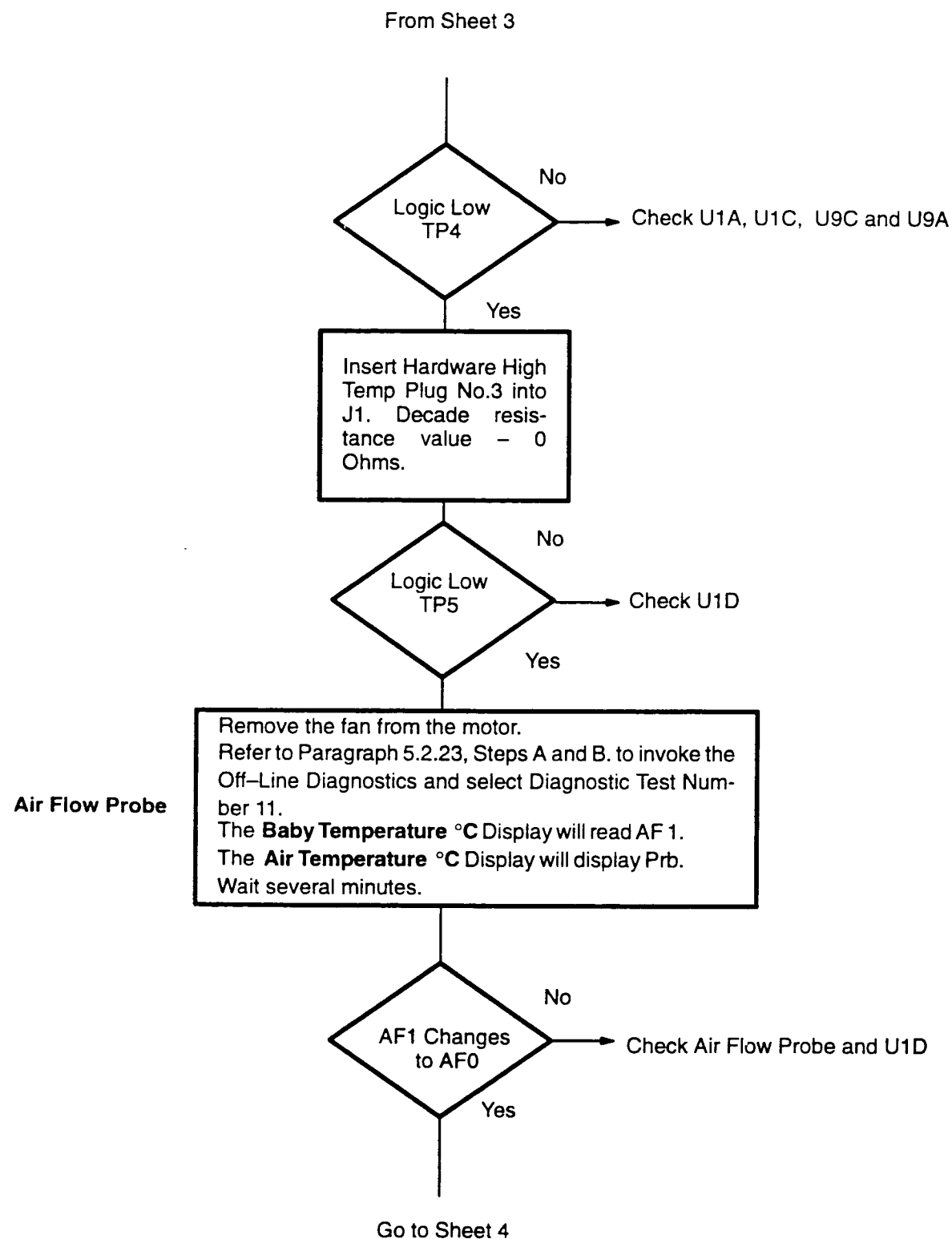

FLOWCHART 5.3 MAIN BOARD TROUBLESHOOTING (Sheet 3 of 4)

5.5 REMOVAL AND REPLACEMENT PROCEDURES

5.5.1

This section provides removal and replacement procedures for components of the Incubator. Removal and replacement procedures for components other than those provided are obvious upon inspection.

5.5.2 CONTROLLER FRONT PANEL AND CONTROLLER PRINTED CIRCUIT BOARDS

Note: Refer to Figure 6.4, Sheet 2, for the Locations of the Printed Circuit Boards.

CONTROLLER FRONT PANEL

1. Refer to Section 4.2.1, Step A, and remove the Controller from the unit.
2. Remove the four Phillips Head screws located behind the handles.
3. Disconnect the Ribbon Cables from J6 and J8 on the Main Printed Circuit Board.

MAIN PRINTED CIRCUIT BOARD

1. Remove the Controller Front Panel as described above.
2. Remove the seven Phillips head screws that hold the Main Board to the Front Panel.

POWER SUPPLY

1. Remove the Controller Front Panel as described above.
2. On the left side of the chassis, remove the two Phillips head screws that secure the heat sink to the five regulators. Remove the heat sink.
3. Remove the three Phillips head screws that secure the front of the board to the standoffs.
4. Slide the board away from the chassis. Disconnect the slip-on connectors from the heater. Disconnect P8, P9 and P10 from the right side of the board.
5. To replace the board, reverse steps 1 through 4.

PROBE BOARD

1. Remove the Controller Front Panel as described above.
2. Remove the two Phillips head screws that board standoffs to the right top surface of the chassis.
3. Remove the two brace jack posts that secure the AUXILIARY PORT to the Side Panel.
3. Disconnect P1 and P2 from the board.
4. To replace the board, reverse steps 1 through 3.

DUAL AIR TEMPERATURE PROBE

1. Remove the Controller Front Panel and Probe Board as described above.
2. Remove the two Phillips head screws that secure the probe to the chassis.

5.5.3 OXYGEN INPUT VALVE FILTER CARTRIDGE

1. Refer to Figure 5.3 and remove the three screws which hold the Input Valve to the Air Intake Filter Cover.
2. Replace the Filter Cartridge (Part No. 68 130 67) and reassemble the Oxygen Input Valve as shown in Figure 5.3.

FIGURE 5.3 OXYGEN INPUT VALVE ASSEMBLY

5.5.4 VHA STAND

VHA STAND ACTUATOR

Refer to Figure 6.14 for all references in parentheses ().

1. Remove the Incubator from the VHA Stand.
2. Remove the cable clamps (35) from the Platform (13).
3. Remove the 8 nuts (50) from the top of the Platform (13). Remove the Platform from the Stand.
4. Pull the Escutcheon (16) straight up and off the stand.

CAUTION: Do not pull Inner Column Assembly (14) up to extend the Gibs (Item 2, Figure 6.15) beyond the top surface of the outer column. If this has been inadvertently done, the Inner Column Assembly must be completely removed and then reassembled using the Procedures described in Para. 5.5.5.

5. Remove the Ground Lug and Cable Clamp (36) at the top of the post by removing the nuts (49).
6. Remove the Mains Panel (8). Disconnect the White Wire from the MAIN POWER Switch (refer to Figure 5.4 for 120V Units or Figure 5.5 for 220V/240V Units).
7. Disconnect the Blue Wire and Brown Wires of the Incubator Power Cord from the MAIN POWER Switch (refer to Figure 5.4 for 120V Units or Figure 5.5 for 220/240V Units).

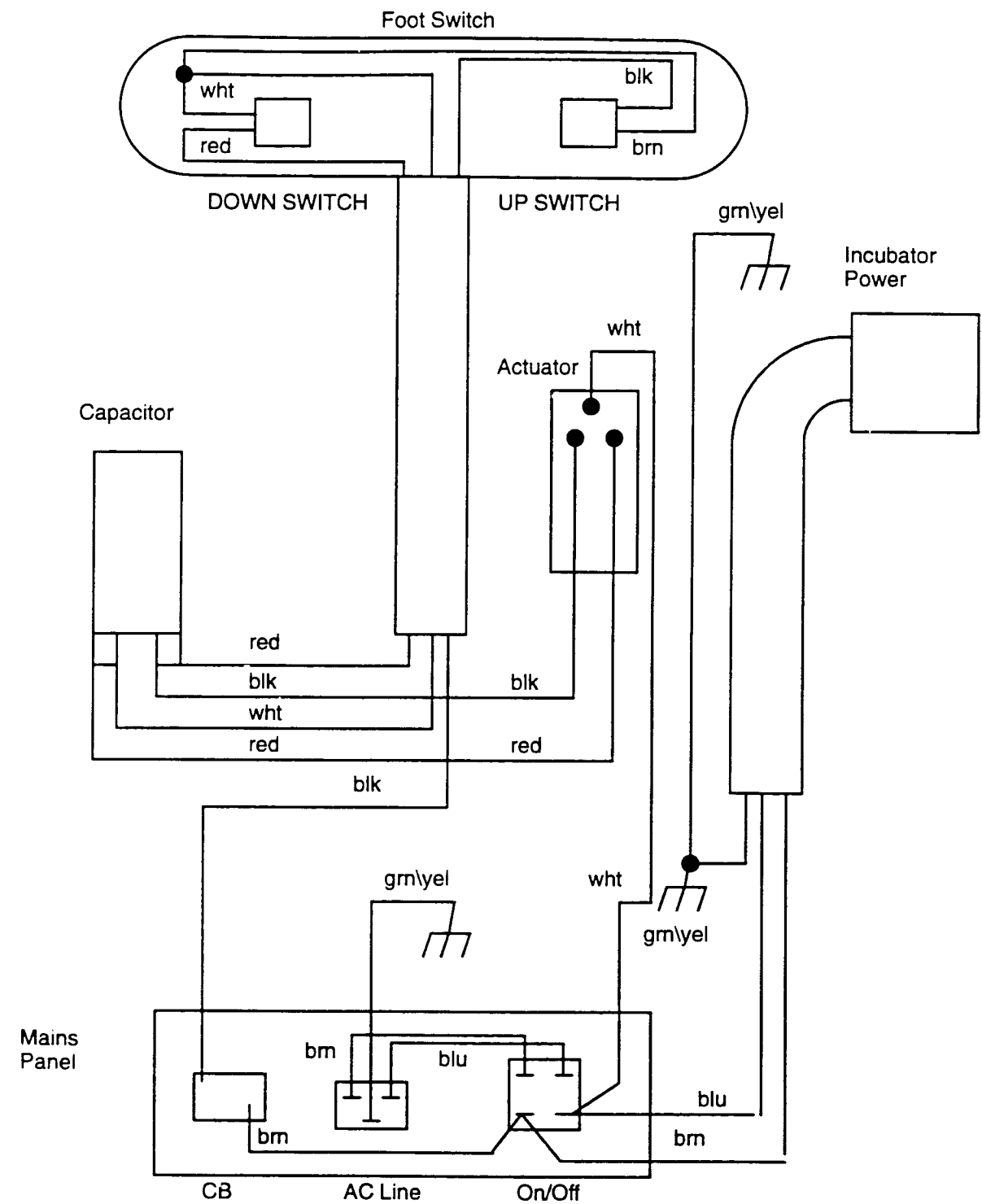

FIGURE 5.4 VHA STAND WIRING DIAGRAM—120V UNITS

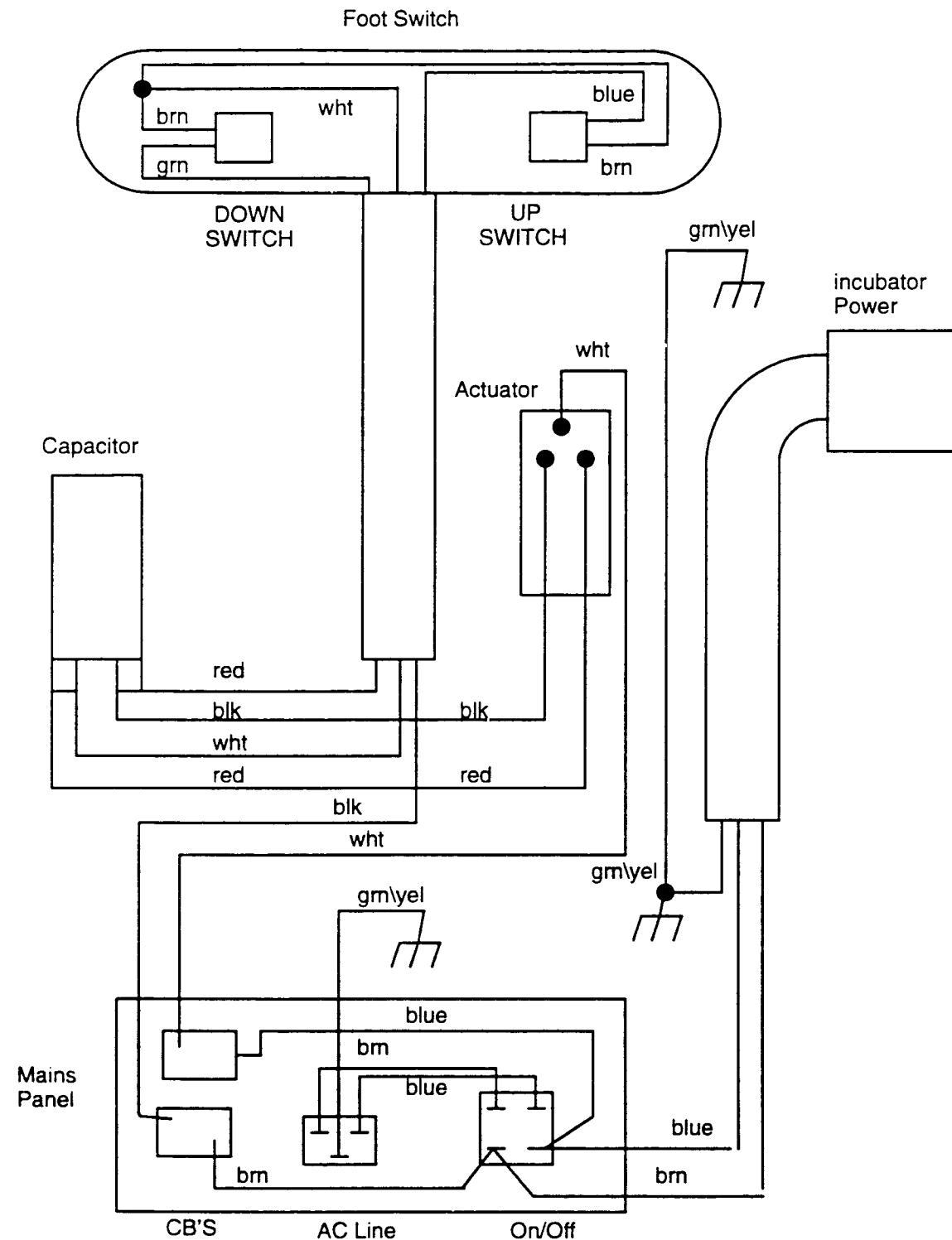

FIGURE 5.5 VHA STAND WIRING DIAGRAM—220/240V UNITS

8. Remove the two nuts (49) holding the Incubator Power Cord Ground Lug and the Ground Lug from the Actuator wiring harness (Green/Yellow Wires) from the Stand. Remove the Cable Clamp (36) that attaches the Actuator wiring harness to the Stand.
9. Remove the two nuts (50) that hold the Actuator from beneath the Stand. Pull the Actuator straight out of the Stand.
10. To install the Actuator, first perform Steps 5 through 9 in reverse order.
11. Connect the unit to the ac line and then, while holding the actuator, extend the actuator to maximum. Temporarily install the Escutcheon on the actuator studs using two nuts (50). Carefully lower and guide the Escutcheon onto the six studs on the stand. Remove the nuts holding the actuator.
12. Install the platform (13) and secure it with 8 nuts (50).
13. Install the cable clamps (35) on the platform and replace the Incubator on the VHA Stand.

UP/DOWN SWITCH

Refer to Figure 6.14 for references in parentheses ().

1. Perform Steps 1 through 4 of the VHA Stand Procedure.
2. Remove the Red and White wires from the Capacitor. Remove the Black wire coming from the Up/Down Switch wiring harness from Circuit Breaker on the Mains Panel (refer to Figure 5.4 for 120V Units or Figure 5.5 for 220V/240V Units).
3. Remove the four nuts (49) that hold the Switch Assembly to the Stand. Remove the Switch Assembly and wiring harness from the Stand.
4. Install the new Switch Assembly by performing Steps 2 and 3 in reverse order. Then perform Steps 11, 12 and 13 of the VHA Stand Actuator Procedure.

PHASE SHIFT CAPACITOR

Refer to Figure 6.14 for references in parentheses ().

1. Perform Steps 1 through 4 of the VHA Removal Procedure.
2. Remove the two Red, one Blue and one Black wires from the capacitor (refer to Figure 5.4 for 120V Units or Figure 5.5 for 220V/240V Units).
3. Remove the nuts (49) and strap (7) holding the Capacitor (4) in place.
4. Install the capacitor by performing Steps 2 and 3 in reverse order. Then perform Steps 11, 12 and 13 of the VHA Stand Actuator Procedure.

5.5.5 REASSEMBLY OF INNER COLUMN INTO OUTER COLUMN (REFER TO FIGURE 5.6)

CAUTION: Do not attempt to reassemble the Inner Column into the Outer Column without using the Gib Pins (Air-Shields Part No. 68 900 02). Improper assembly may cause damage to the Gibs.

1. If necessary, remove the inner column assembly from the outer column.
2. Use a screwdriver to push each Gib back and insert the Gib Pins into the slots (refer to Figure 3.) to retain the Gibs.
3. Insert the Inner Column into the Outer Column until the four lower Gib Pins rest on the top surface of the Outer Column.
4. Remove the four lower Gib Pins. Push the Inner Column down into the Outer Column until the upper Gib Pins contact the top surface of the Outer Column. Remove the Gib Pins.
5. Continue to push the Inner Column down until the Gibs are below the two surfaces of the Outer Column.

5.6 ALTERNATIVE TEST EQUIPMENT

5.6.1 FRONT END TEST PLUG ALTERNATIVE

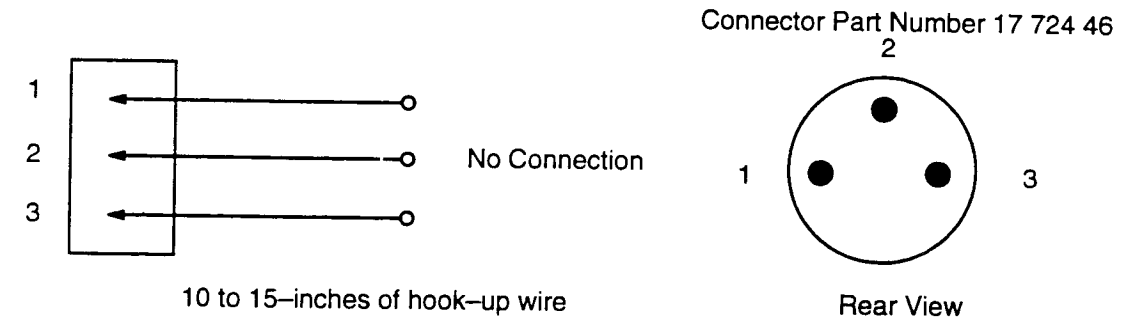

5.6.2 HIGH TEMP TEST PLUG ALTERNATIVE

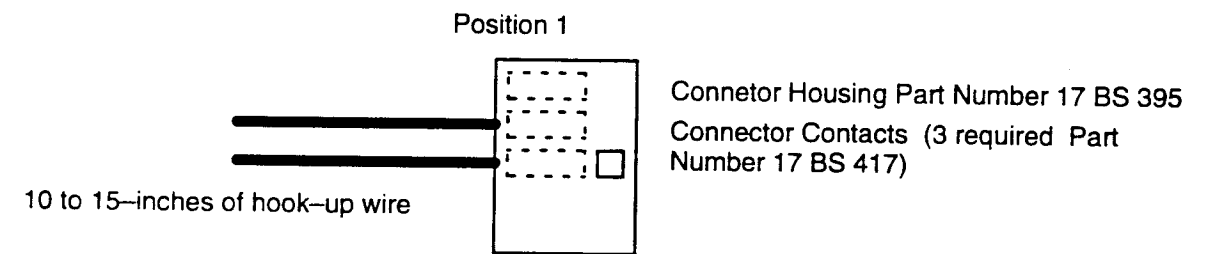

FIGURE 5.6 INSERTION OF GIB PINS

SECTION 6 REPLACEMENT PARTS

6.1 GENERAL

This section provides parts lists for the Isolette® Infant Incubators, Models C400 QT® and C450 QT®. Part numbers of operator replaceable parts, accessories and single use items are provided below:

(This page is intentionally left blank.)

OPERATOR REPLACEABLE PARTS	PART NO.
AC LINE CORD 120V	17 AZ 100
AC LINE CORD 220V	17 AZ 200
AUXILIARY AIR TEMPERATURE PROBE	68 209 81
SKIN TEMPERATURE PROBE	68 209 70
REAR INNER WALL	68 526 40
UPPER INNER WALL	68 232 22
MICROFILTER (Box of 4)	26 945 70
WEIGHING HOOK (5" for Weighing Scale)	12 621 70
(15" required when Weighing Scale is on Accessory Shelf)	26 610 76
WEIGHING SLING	26 830 20
TUBING ACCESS GROMMET	68 120 45
 OPERATOR REPLACEABLE PARTS FOR WARM WEIGH® I20 SCALE	
MATTRESS, DISPOSABLE (10 per case)	67 903 86
MATTRESS TRAY	SH82000000
CALIBRATED WEIGHT SET	03 310 15
5 Kg. WEIGHT	03 310 16
 ACCESSORIES	
GUARD RAIL ASSEMBLY	68 410 70CC
ACCESSORY SHELF (120V with Lamp, Standard Cabinet Stand)	26 610 80
ACCESSORY SHELF (120V without Lamp, Standard Cabinet Stand)	26 610 81
STERILIZER TANK	26 517 01
WEIGHING SCALE (Sling-type)	26 830 70
I.V. POLE (Mounts on Standard Cabinet Stand)	68 452 70
WARM WEIGH® SCALE, MODEL I20	03 320 70
OXYGEN CYLINDER SUPPORT	26 840 70
POST (2) /SWIVEL SHELVES (2) (Standard Cabinet Stand)	68 401 70
I.V. POLE (Mounts on VHA or Standard Cabinet Stand Swivel Shelf Post)	78 166 71
REMOTE ALARM MODULE (Requires I.V. Pole for Mounting)	68 411 70
MICRO-LITE™ PHOTOTHERAPY SYSTEM	68 420 70
 ACCESSORIES FOR OPTIONAL VHA STAND	
POST (1) /SWIVEL SHELF (1)	68 405 66
CABINET MODULE	68 404 53
DRAWER MODULE	68 404 54
SIDE SHELF FOR CABINET OR DRAWER MODULE	68 405 68
SEE-THROUGH DOOR FOR CABINET MODULE	68 405 38
METAL DOOR FOR CABINET MODULE	68 405 59

TABLE 6.1 REPLACEMENT PARTS (Continued)

DEW-ETTE® 2 INCUBATOR HUMIDIFIER	
120V Version	68 135 70
220/240V Version	68 135 80
DEW-ETTE® 2 MOUNTING PLATE W/OXYGEN INLET	
English	68 125 60
Spanish	68 125 61
RAIL SYSTEM	
RAIL SYSTEM FOR STANDARD CABINET STAND	68 407 70
RAIL SYSTEM FOR VHA STAND	68 407 80
MONITOR SHELF PACKAGE	68 408 00
ATHENA® MONITOR SHELF ASSEMBLY	68 408 15
ATHENA® MONITOR PAM KIT	68 408 70
UTILITY POLE ASSEMBLY	68 408 20
I.V. TREE ASSEMBLY	68 408 30
MODURA ASSEMBLY	68 408 45
STUB MOUNT ASSEMBLY	68 408 40
OXYGEN FLOWMETER KIT	68 408 50
AIR FLOWMETER KIT	68 408 55
SUCTION KIT	68 408 60
BLENDER KIT	68 408 65
MICRO-LITE™ PIVOT ARM ASSEMBLY	68 423 80
SINGLE USE ITEMS	
ENTRY PORT SLEEVES (Case of 100)	26 920 70
ACCESS DOOR CUFFS DISPOSABLE (Case of 100)	68 120 70
MATTRESSES (Case of 10)	79 265 10
CRITTER COVERS® PROBE COVERS (Box of 100)	68 209 46
CRITTER COVERS® PROBE COVERS (Ctn of 600)	68 209 45
CUDDLE COVERS™ INCUBATOR SHEETS (Ctn of 12)	78 168 20
CUDDLE COVERS™ RECEIVING BLANKETS (Ctn of 24)	78 169 20
KLEENASEPTIC®-b CLEANSER (6 One-quart bottles per case w/one spray pump)	79 251 73
VAPASEPTIC® AIR SANITIZER (Case of 12)	79 250 71
PREMI-PROBE® 1, DISPOSABLE TEMP PROBE, (Box of 10)	68 209 20
PREMI-PROBE® 1, DISPOSABLE TEMP PROBE, (Ctn of 100)	68 209 30
STORAGE COVERS (Pack of 50)	26 920 72
HUMIDITY INDICATOR CARDS (20 Packs of 5)	68 120 43

(This page is intentionally left blank.)

TABLE 6.1 HOOD ASSEMBLY, GROUP 2 UNITS, PARTS LIST

(SHEET 1 OF 2)

REFER TO FIGURE 6.2 AND TABLE 6.2 FOR ACCESS DOOR PARTS.

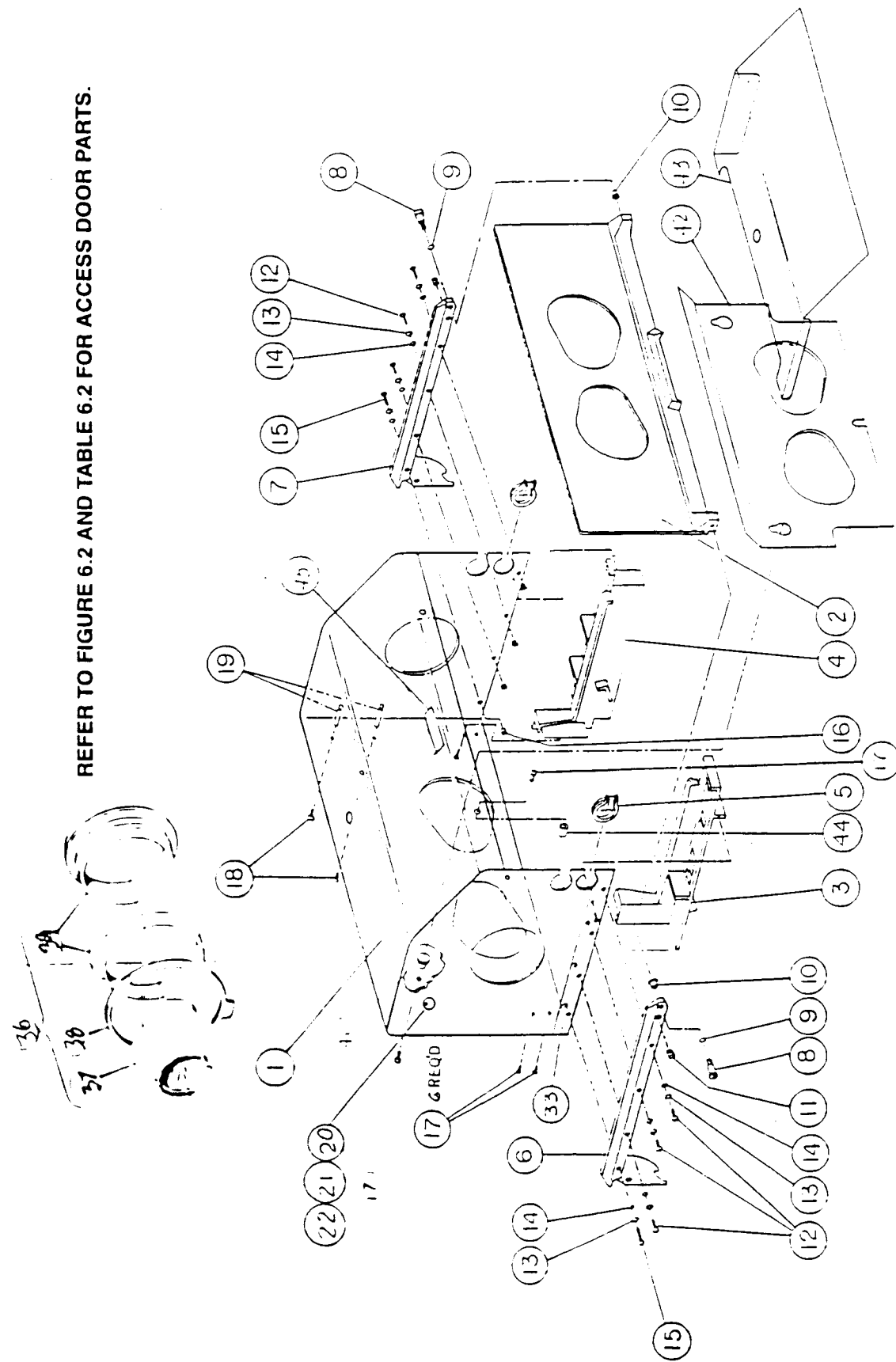

FIGURE 6.1 PARTS LOCATION DIAGRAM, HOOD ASSEMBLY, GROUP 2 UNITS

ITEM NO.	REFERENCE DESIG.	DESCRIPTION	PART NUMBER
1**		HOOD ASSEMBLY, 4 ACCESS DOORS, 2 IRIS PORTS	68 527 91
1**		HOOD ASSEMBLY, 5 ACCESS DOORS, 1 IRIS PORT	68 527 93
1**		HOOD, INCUBATOR (ACRYLIC ONLY)	
		4 ACCESS DOORS, 2 IRIS PORTS REPL KIT ENG	68 911 21
		5 ACCESS DOORS, 1 IRIS PORT REPL KIT ENG	68 911 22
2		ACCESS PANEL ASSY (REFER TO TABLE 6.)	
3		BAFFLE LEFT	68 156 34
4		BAFFLE RIGHT	68 156 28
5		ACCESS GROMMET	68 120 45
6		HOOD MOUNT, LEFT SIDE	68 121 15
7		HOOD MOUNT, RIGHT SIDE	68 121 05
8*		SCREW, SHOULDER SLOTTED HEAD	68 121 30
9*		WASHER, NON-METALLIC, 3/8 ID	68 121 40
10*		BEARING FLANGE, 3/8 ID	68 121 35
11*		PLUNGER SPRING	68 121 45
12		SCREW, 10 - 32 X 5/8, LG, TR, PH SS	99 042 58
13		WASHER, NO. 10, LOCK INTER, SS	99 123 92
14		WASHER, NO. 10, FLAT SS 0.062 THK	99 123 62
15		SCREW, 10 - 32, 7/8 LG, TR, PH, SS	99 043 18
16		STUD, THREADED, 10 - 32	26 301 14
17		SCREW, 6 - 32 X 1/2, TR, PH, SS	99 023 63
18		SCREW, 6 - 32 X 3/4, TR, PH, SS	99 024 69
19		HUMIDITY CARD MOUNTING STUD	68 120 41
20		THREADED STUD, 10 - 32	26 301 14
21		COVER PLATE	26 651 22
22		SCREW, 10 - 32 X 1/4	99 040 51
23		HINGE PIVOT	68 510 05
24		TORSION SPRING	68 510 10
25		DOOR ASSEMBLY	68 902 85
26		BUMPER CLR POLYURETH, SELF ADHES	78 293 10
27		ACCESS DOOR LATCH ASSEMBLY, INCLUDES ITEM 28	68 902 97
28		O-RING, 3/8 DIA X 1/2 OD X 1/16 NPRN	99 160 54
29		ACCESS DOOR CUFF, REUSABLE	68 120 56
29		ACCESS DOOR CUFF, DISPOSABLE	68 120 70
30		ACCESS DOOR GASKET	68 120 01
31		LATCH PIVOT	68 510 40
32		SCREW, 6 - 32 X 3/8 FL PH SS	99 023 39
33		WHITE PLASTIC TRIM STRIP	68 147 00
34		REINFORCING DISK	68 156 03
35		TRIM STRIP, WHITE	
		(NOT SHOWN) COVERS SCREWS OF ITEMS 6 AND 7	68 121 25

*Not supplied with Hood Assembly - Must be ordered separately.

**Also order Quantity 2 of Item 35 - Trim Strip

TABLE 6.1 HOOD ASSEMBLY, GROUP 2 UNITS, PARTS LIST
(SHEET 2 OF 2)

ITEM NO.	REFERENCE DESIG.	DESCRIPTION	PART NUMBER
36		IRIS PORT ASSEMBLY	68 120 74
37		IRIS PORT SLEEVE, REUSABLE	12 615 01
		IRIS PORT SLEEVE, DISPOSABLE	26 920 70
38		RETAINING RING	68 120 32
39		RING ASSEMBLY	68 120 76
40		SMALL RETAINER KNOB	68 156 62
41		SCREW, 6 - 32 X 1.12 TR PH SS NYLOK	99 025 44
42		HEAT SHIELD ASSY (REAR) REPL KIT	68 904 08
43		HEAT SHIELD ASSY (TOP) REPL KIT	68 904 14
44		SPACER, 6 - 32 , 0.38 OD X 0.44 LG	68 232 24
45		NO FILTER COVER WARNING LABEL	68 115 40
46		RETAINER KNOB, 0.75 OD X 0.66 LG	68 232 55

(This page is intentionally left blank.)

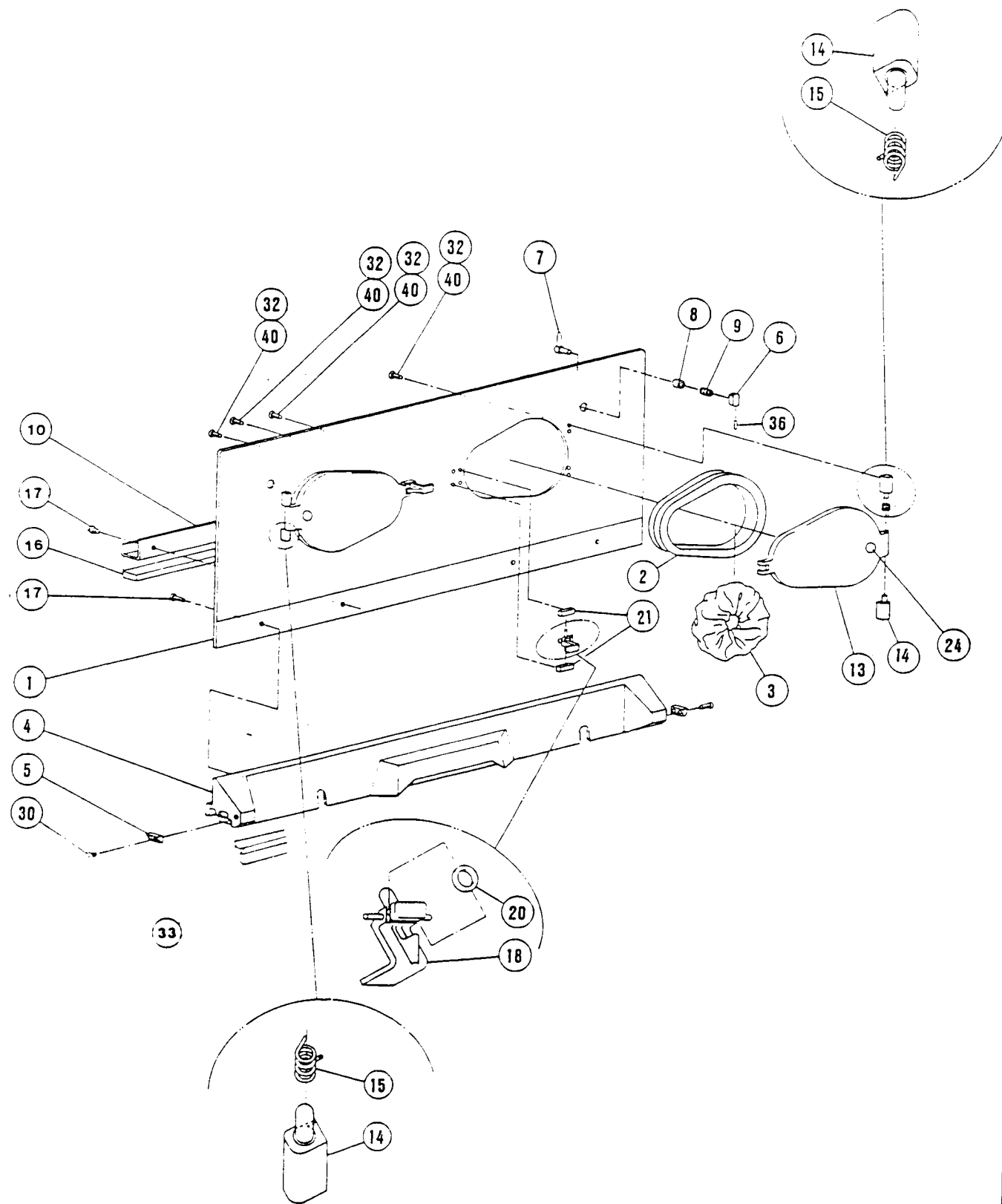

FIGURE 6.2 PARTS LOCATION DIAGRAM, ACCESS PANEL ASSEMBLY,
GROUP 2 UNITS

TABLE 6.2 ACCESS PANEL ASSEMBLY, GROUP 2 UNITS, PARTS LIST

(SHEET 1 OF 1)

ITEM NO.	REFERENCE DESIG.	DESCRIPTION	PART NUMBER
1		ACCESS PANEL ASSY	68 528 80
		PANEL, ACCESS, REPLACEMENT KIT, (INCLUDES ITEMS 6,7,8,9,36,38, 39 AND 41)	
		ENG	68 911 10
		SPANISH	68 911 11
		FRENCH	68 911 12
		GERMAN	68 911 13
		ITALIAN	68 911 14
2		ACCESS DOOR GASKET	68 120 01
3		CUFF, ACCESS DOOR	68 120 56
4		STRIP, ACCESS PANEL MOUNTING, FRONT	68 121 24
5		PLATE, STRIKER	68 121 55
6		REFER TO ITEM 37	
7		REFER TO ITEM 37	
8		REFER TO ITEM 37	
9		REFER TO ITEM 37	
10		DECK CLOSE OFF BRACKET ASSY (INCLUDES ITEM 16)	68 232 19
11		NOT USED	
12		NOT USED	
13		DOOR, ASSEMBLY	68 902 85
14		PIVOT, HINGE	68 510 05
15		SPRING, TORSION	68 510 10
16		DECK CLOSE OFF BRACKET GASKET	68 232 15
17		SCREW, 8 - 32 X 1/2 TR PH SS	99 031 99
18		LATCH ASSY, ACCESS DOOR	
		INCLUDES ITEM 20	68 510 26
19		NOT USED	
20		O RING, 3/8 ID x 1/2 OD x 1/16, NPRN	99 160 54
21		PIVOT, LATCH	68 510 40
22		NOT USED	
23		WHITE VINYL GASKET	68 232 16
24		BUMPER, CLR POLYURETH, SELF ADH	78 293 10
25		SPACER, 1/2 OD X 0.166 ID X 3/8 LG	68 156 66
26		NOT USED	
27		NOT USED	
28		ADHESIVE, CYACRLT, LOC 404/EAST 910	AR
29		ADHESIVE, CLEAR 3M4693	AR
30		SCREW, 6 - 32 x 1/2 FL PH SS	99 023 94
32		SCREW, 6 - 32 x 7/16 NYLOK	99 023 64
33		WHITE VINYL GASKET, 0.25 W X 17 LG	68 234 02
		WHITE VINYL GASKET, 0.25 W X 7 LG (QTY 2)	68 234 03
34		SCREW, 6- 32 X 3/8	99 023 39
35		NOT USED	
36		REFER TO ITEM 37	
37		PAWL LATCH REPLACEMENT KIT	68 902 96
38		PINK QT/ANIMALS LABEL	68 512 36
39		WARNING; INFANT SAFETY LABEL	68 501 20
40		COMPOUND, RTV SILICONE RUBBER, CLR	AR
41		PATENT PENDING LABEL	68 512 13

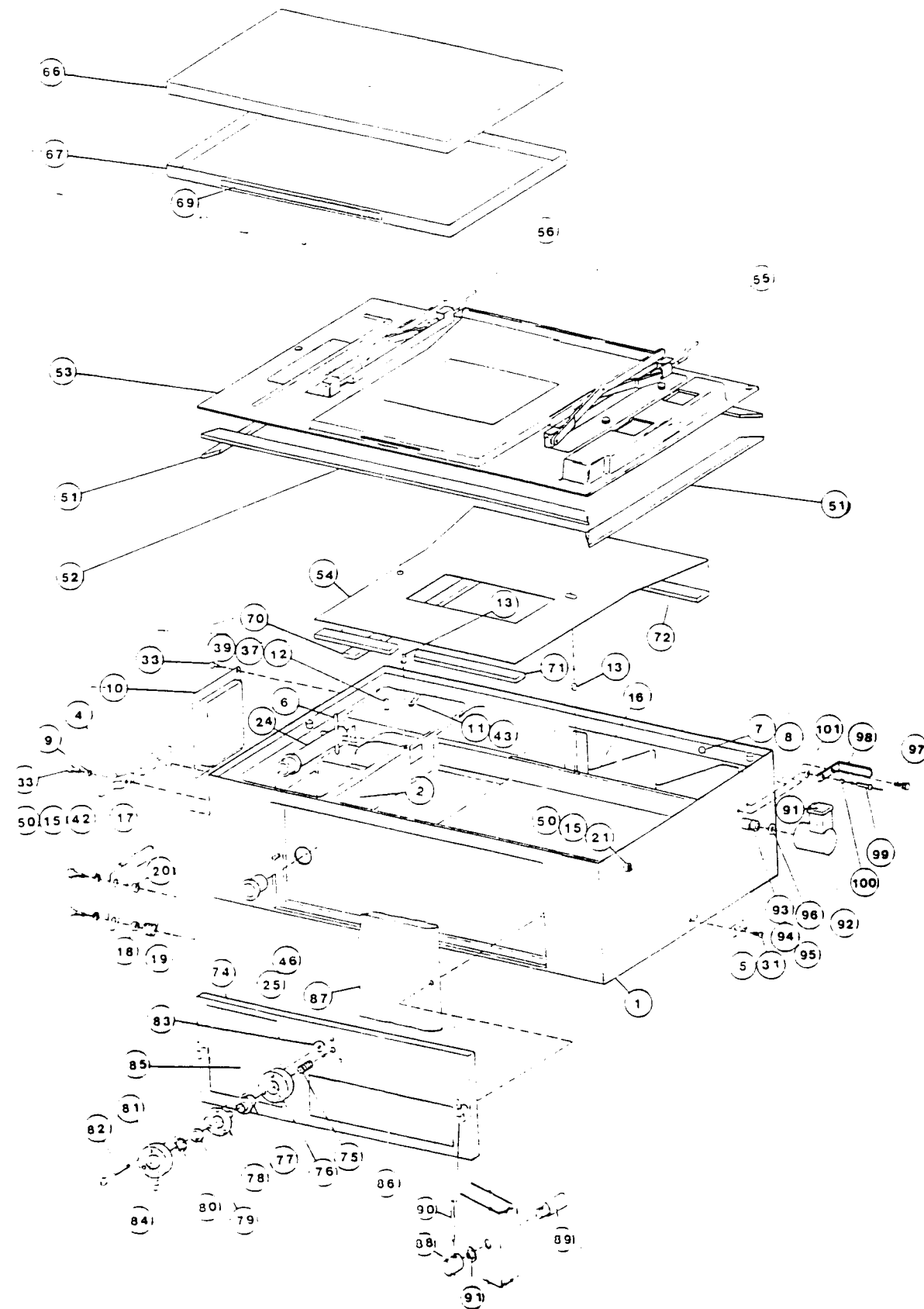

FIGURE 6.3 PARTS LOCATION DIAGRAM, SHELL AND DECK ASSEMBLY,
GROUP 2 UNITS

TABLE 6.3 SHELL AND DECK ASSEMBLY, GROUP 2 UNITS, PARTS LIST

(SHEET 1 OF 3)

ITEM NO.	REFERENCE DESIG.	DESCRIPTION	PART NUMBER
1		SHELL	68 507 00
2		CASTING	26 100 30
3		NOT USED	
4		CABLE HOOK	68 604 30
5		LATCH HOOK	24 144 01
6		PIN CROSS FEED PIPE	68 231 01
7		SCREW, 8 - 32 X 3/8 RD PH SS	99 031 37
8		WHITE RTV	AR
9		LOCK WASHER, EXT TOOTH #4	99 121 37
10		RECESSED OUTLET PANEL	68 528 01
		RECESSED OUTLET PANEL LABEL - C400, 120V ENG	68 524 40
		RECESSED OUTLET PANEL LABEL - C400, 120V SPN	68 524 41
		RECESSED OUTLET PANEL LABEL - C400, 120V FRN	68 524 42
		RECESSED OUTLET PANEL LABEL - C400, 220/240V ENG	68 524 43
		RECESSED OUTLET PANEL LABEL - C400, 220/240V SPN	68 524 44
		RECESSED OUTLET PANEL LABEL - C400, 220/240V FRN	68 524 45
		RECESSED OUTLET PANEL LABEL - C400, 220V GER	68 524 46
		RECESSED OUTLET PANEL LABEL - C400, 220/240V ITL	68 524 47
		RECESSED OUTLET PANEL LABEL - C450, 120V ENG	68 525 40
		RECESSED OUTLET PANEL LABEL - C450, 120V SPN	68 525 41
		RECESSED OUTLET PANEL LABEL - C450, 120V FRN	68 525 42
		RECESSED OUTLET PANEL LABEL - C450, 220/240V ENG	68 525 43
		RECESSED OUTLET PANEL LABEL - C450, 220/240V SPN	68 525 44
		RECESSED OUTLET PANEL LABEL - C450, 220/240V FRN	68 525 45
		RECESSED OUTLET PANEL LABEL - C450, 220V GER	68 525 46
		RECESSED OUTLET PANEL LABEL - C450, 220/240V ITL	68 525 47
11		LEAF SPRING	68 110 41
12		RAMP LATCH	68 110 42
13		DELTRAN SCREW, 10 - 24 X 0.25 X 0.125	68 232 03
14		NOT USED	
15		SLOTTED SHOULDER SCREW	68 110 52
16		HUMIDITY RESERVOIR BAFFLE	26 101 02
17		LATCH HANDLE	68 110 55
18		SPACER NON-METALLIC	68 110 56
19		TORSION SPRING	68 110 57
20		SPACER NON-METALLIC	68 110 58
21		SPACER NON-METALLIC	68 110 59
22		DELTRAN SCREW, 10 - 24 X 0.25 X 0.437	68 232 03
23		NOT USED	
24		CROSS FEED PIPE	68 112 05
25		FILTER GROMMET	68 112 15
27		DECK RETAINING KNOB REPL KIT	68 901 22
28		BEZEL ASSEMBLY	68 504 75
31		SCREW, 4 - 40 X 5/16 FL PH SS	99 010 77
32		THUMB SCREW, 4 - 40 X 1/4	99 010 63
33		SCREW, 4 - 40 X 5/16 TR PH SS	99 010 76

TABLE 6.3 SHELL AND DECK ASSEMBLY, GROUP 2 UNITS, PARTS LIST

(SHEET 2 OF 3)

ITEM NO.	REFERENCE DESIG.	DESCRIPTION	PART NUMBER
35		SCREW, 8 - 32 X 3/8 RD PH SS	99 031 37
37		HEX NUT, 8 -32 SS	99 106 01
38		NOT USED	
39		LOCK WASHER, #8	99 122 95
40		NOT USED	
41		WASHER, 0.560 OD X 0.25 ID PLASTIC	99 125 57
42		WASHER, 0.38 OD X 0.62 ID	99 126 70
44		PIN, 1/8 DIA X 1 1/2 LG SS	99 143 96
45		O-RING 5/8 X 3/4 X 1/16	99 161 04
46		DOW CORNING LUBE #111	AR
47		WHITE RTV COMPOUND	AR
50		LOCTITE #222	AR
51		MAIN DECK GASKET 13-INCHES LONG	68 232 30
52		MAIN DECK GASKET 16-INCHES LONG	68 232 31
53		MAIN DECK ASSEMBLY (INCLUDES ITEMS 51, 52 AND 63)	68 904 60
54		INNER DECK	68 904 80
55		ELEVATOR ASSY RIGHT HAND	68 521 47
56		ELEVATOR ASSY LEFT HAND	68 521 48
63		CORRECT OPERATION LABEL	68 234 10
64		REDUCER BUSHING, 1/4 NPT X 1/8 FNPT	68 504 09
66		MATTRESS	68 142 71
67		MATTRESS TRAY ASSY ENG (INCLUDES ITEM 69)	68 901 00
		MATTRESS TRAY ASSY SPN	68 901 01
		MATTRESS TRAY ASSY FRN	68 901 02
		MATTRESS TRAY ASSY GER	68 901 03
		MATTRESS TRAY ASSY ITL	68 901 04
69		MATTRESS TRAY WARNING LABEL ENG	68 160 30
		MATTRESS TRAY WARNING LABEL SPN	68 160 31
		MATTRESS TRAY WARNING LABEL FRN	68 160 32
		MATTRESS TRAY WARNING LABEL GER	68 160 33
		MATTRESS TRAY WARNING LABEL ITL	68 160 34
70		GASKET, 1/2 W X 15.5 LG	68 232 48
71		GASKET, 1/2 W X 13.84 LG	68 232 49
72		GASKET, 1/2 W X 17 LG	68 232 49
74		FILTER COVER ASSEMBLY, ENG (INCLUDES ITEM 75 THRU 88)	68 507 40
		FILTER COVER ASSEMBLY, SPN (INCLUDES ITEM 75 THRU 88)	68 507 41
		FILTER COVER ASSEMBLY, FRN (INCLUDES ITEM 75 THRU 88)	68 507 42
		FILTER COVER ASSEMBLY, GER (INCLUDES ITEM 75 THRU 88)	68 507 43
		FILTER COVER ASSEMBLY, ITL (INCLUDES ITEM 75 THRU 88)	68 507 44

TABLE 6.3 SHELL AND DECK ASSEMBLY GROUP 2 UNITS, PARTS LIST

(SHEET 3 OF 3)

ITEM NO.	REFERENCE DESIG.	DESCRIPTION	PART NUMBER
75		COMPRESSION SPRING	68 130 65
76		CYLINDER	68 130 55
77		FILTER CARTRIDGE	68 130 67
78		DIAPHRAGM	68 130 57
79		NON-METALLIC WASHER	68 130 51
80		RETAINING RING, WAL 5105-62 SS	99 182 93
81		CAP	68 130 60
82		SCREW, 6- 32 X 1.75" OV PH SS	99 026 18
83		NON-METALLIC WASHER	68 130 52
84		OXYGEN LIMITER LABEL, ENG	68 133 35
		OXYGEN LIMITER LABEL, SPN	68 133 36
		OXYGEN LIMITER LABEL, FRN	68 133 37
		OXYGEN LIMITER LABEL, GER	68 133 38
		OXYGEN LIMITER LABEL, ITL	68 133 34
85		OXYGEN CONCENTRATION LABEL, ENG	68 133 10
		OXYGEN CONCENTRATION LABEL, SPN	68 133 11
		OXYGEN CONCENTRATION LABEL, FRN	68 133 12
		OXYGEN CONCENTRATION LABEL, GER	68 133 13
		OXYGEN CONCENTRATION LABEL, ITL	68 133 15
86		FILTER COVER LABEL, ENG	26 330 60
		FILTER COVER LABEL, SPN	26 330 61
		FILTER COVER LABEL, FRN	26 330 62
		FILTER COVER LABEL, GER	26 330 63
		FILTER COVER LABEL, ITL	26 330 64
87		AIR FILTER (BOX OF 4)	26 945 70
88		FILTER COVER KNOB	68 130 30
89		FILTER COVER KNOB SHAFT	68 130 35
90		FILTER COVER KNOB HANDLE	68 130 40
91		WASHER, 0.38 ID X 0.62 OD X 0.15 THK NYLON	99 126 11
92		FILL PIPE CAP	12 209 01
93		FILL SPOUT	26 200 02
94		SEALING WASHER	26 204 00
95		SEALING NUT	26 205 00
96		O-RING, 5/8 X 3/4 X 1/16	99 161 04
97		NYLON THUMB SCREW, 4 - 40 X 1/4	99 010 63
98		FILL SPOUT STOP	68 110 50
99		POP RIVET, 1/8 LARGE FLANGE	99 131 70
100		SPACER, 0.140 ID X 0.250 OD X 0.125 LG	99 121 96
101		CONICAL WASHER, PLASTIC DISC 0.261 ID	99 125 57

TABLE 6.4 HOOD ASSEMBLY, GROUP 1, PARTS LIST
(SHEET 1 OF 1)

HOOD ASSEMBLY, DOUBLE WALL 68 117 70
HOOD ASSEMBLY, SINGLE WALL 68 117 75

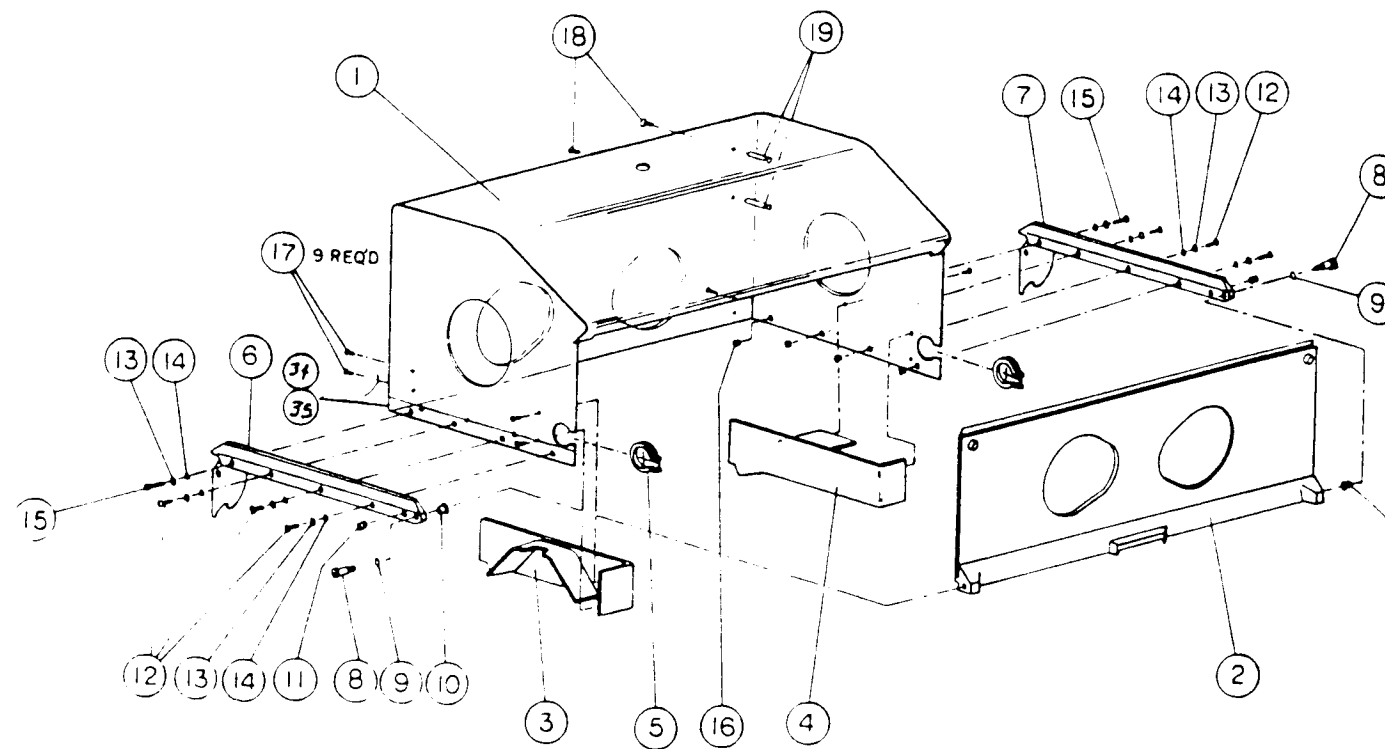

IRIS PORT ASSEMBLY

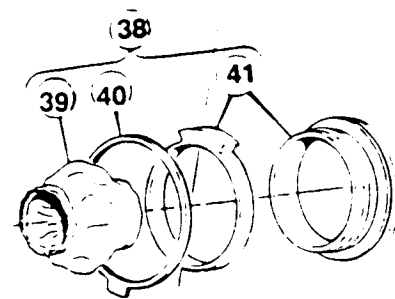

REFER TO FIGURE 6.5 AND TABLE 6.5 FOR ACCESS DOOR PARTS.

FIGURE 6.4 PARTS LOCATION DIAGRAM, HOOD ASSY, GROUP 1

ITEM NO.	REFERENCE DESIGNATION	DESCRIPTION	PART NUMBER
1**		HOOD, INCUBATOR (ACRYLIC ONLY)	68 511 70
2*		ACCESS PANEL (REFER TO TABLE 6.19)	68 159 90
		SINGLE WALL	68 159 91
3		BAFFLE LEFT (WHITE COLORED PLASTIC)	68 156 72
4		BAFFLE RIGHT (WHITE COLORED PLASTIC)	68 156 76
5		ACCESS GROMMET	68 120 45
6		HOOD MOUNT, LEFT SIDE	68 121 10
7		HOOD MOUNT, RIGHT SIDE	68 121 00
8*		SCREW, SHOULDER SLOTTED HEAD	68 121 30
9*		WASHER, NON-METALLIC, 3/8 ID	68 121 40
10*		BEARING FLANGE, 3/8 ID	68 121 35
11*		PLUNGER SPRING	68 121 45
12		SCREW, 10 - 32 X 5/8, LG, TR, PH SS	99 023 58
13		WASHER, NO. 10, LOCK INTER, SS	99 123 92
14		WASHER, NO. 10, FLAT SS 0.062 THK	99 123 62
15		SCREW, 10 - 32, 7/8 LG, TR, PH, SS	99 043 18
16		STUD, THREADED, 10 - 32	26 301 14
17	(See Note)	SCREW, 6 - 32 X 7/16, TR, PH, SS	99 023 63
18		SCREW, 6 - 32 X 3/4, TR, PH, SS	99 024 69
19		HUMIDITY CARD MOUNTING STUD	68 120 41
26		NOT USED	
27		NOT USED	
28		NOT USED	
29		NOT USED	
30		NOT USED	
31		NOT USED	
32		NOT USED	
33		WHITE PLASTIC TRIM STRIP	68 147 00
34		REINFORCING DISK	68 156 03
35		HEAT SHIELD, REAR (NOT SHOWN)	68 122 71
36		HEAT SHIELD SPACERS, FRONT (NOT SHOWN)	68 122 05
37		HEAT SHIELD SPACERS, REAR (NOT SHOWN)	68 122 10
38		IRIS PORT ASSY	68 120 74
39		SLEEVE IRIS PORT, REUSABLE (P/O ITEM 38)	12 615 00
40		RETAINER RING, IRIS PORT (P/O ITEM 38)	68 120 32
41		RING ASSY, IRIS PORT (P/O ITEM 38)	12 612 74
42*		TRIM STRIP (NOT SHOWN) COVERS SCREWS OF ITEM 6	68 400 26
43*		HOOD PIVOT SCREW AND WASHER RETROFIT KIT	68 902 75

*Not supplied with Hood Assembly - Must be ordered separately.

**Also order Quantity 2 of Item 42 - Trim Strip

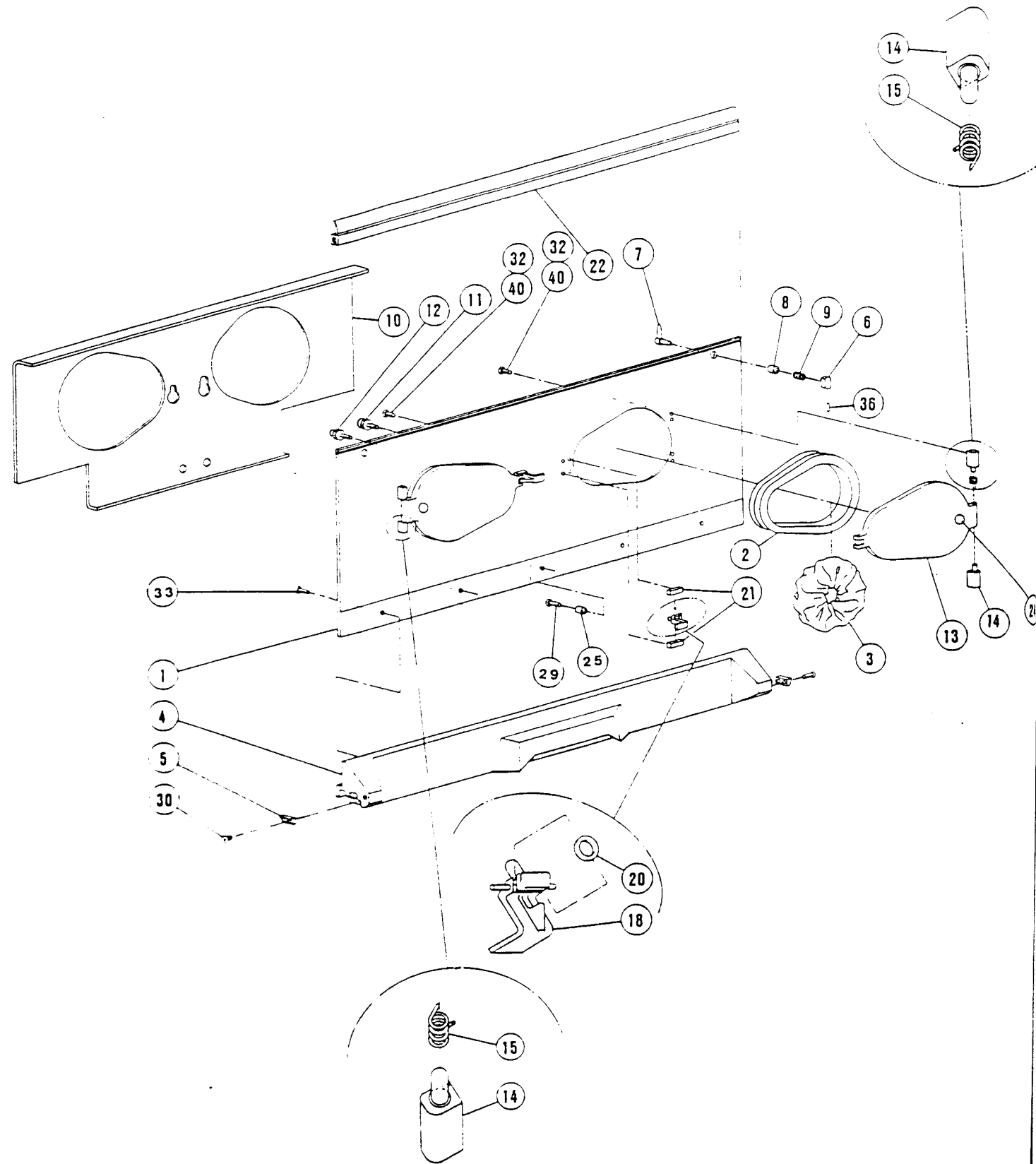

FIGURE 6.5 PARTS LOCATION DIAGRAM, ACCESS PANEL ASSEMBLY, GROUP 1

TABLE 6.5 ACCESS PANEL ASSEMBLY, GROUP 1, PARTS LIST
(SHEET 1 OF 1)

ITEM NO.	REFERENCE DESIGNATION	DESCRIPTION	PART NUMBER
		PANEL ASSEMBLY DOUBLE WALL	68 528 70
		SINGLE WALL	68 528 71
1		PANEL, ACCESS	68 512 00
2		GASKET, ACCESS DOOR, REUSABLE	68 120 01
		GASKET, ACCESS DOOR, DISPOSABLE	68 120 70
3		CUFF, ACCESS DOOR	68 120 56
4		STRIP, ACCESS PANEL MOUNTING, FRONT	68 121 24
5		PLATE, STRIKER	68 121 55
6		REFER TO ITEM 37	
7		REFER TO ITEM 37	
8		REFER TO ITEM 37	
9		REFER TO ITEM 37	
10		SHIELD, HEAT	68 157 56
11		KNOB, RETAINER, LARGE	68 156 63
12		KNOB, RETAINER, SMALL	68 156 62
12A		SCREW, 6 - 32 x 1 1/8", LG, PH, SS, MOUNTS	
		ITEMS 11 AND 12	99 025 43
13		DOOR, ASSEMBLY	68 902 85
14		PIVOT, HINGE	68 510 05
15		SPRING, TORSION	68 510 10
16		NOT USED	
17		NOT USED	
18		LATCH ASSY, ACCESS DOOR	
		INCLUDES ITEM 20	68 902 97
19		NOT USED	
20		O RING, 3/8 ID x 1/2 OD x 1/16, NPRN	99 160 54
21		PIVOT, LATCH	68 510 40
22		STRIP, SEALING	68 512 10
23		NOT USED	
24		BUMPER, CLR POLYURETH, SELF-ADH	78 293 10
25		STOP	68 157 66
26		NOT USED	
27		NOT USED	
28		NOT USED	
29		SCREW, 8 - 32 x 7/8 FL PH SS	99 033 19
30		SCREW, 6 - 32 x 1/4 FL PH SS	99 022 75
31		NOT USED	
32		SCREW, 6 - 32 x 7/16 FL PH SS NYLOK	99 023 64
33		SCREW, 8 - 32 x 3/8 TR PH SS	99 031 38
34		NOT USED	
35		NOT USED	
36		REFER TO ITEM 37	
37		PAWL LATCH REPLACEMENT KIT	68 902 96
38		NOT USED	
39		NOT USED	
40		COMPOUND, RTV SILICONE RUBBER, CLR	99 902 59

TABLE 6.6 SHELL AND DECK ASSEMBLY, GROUP 1, PARTS LIST

(SHEET 1 OF 3)

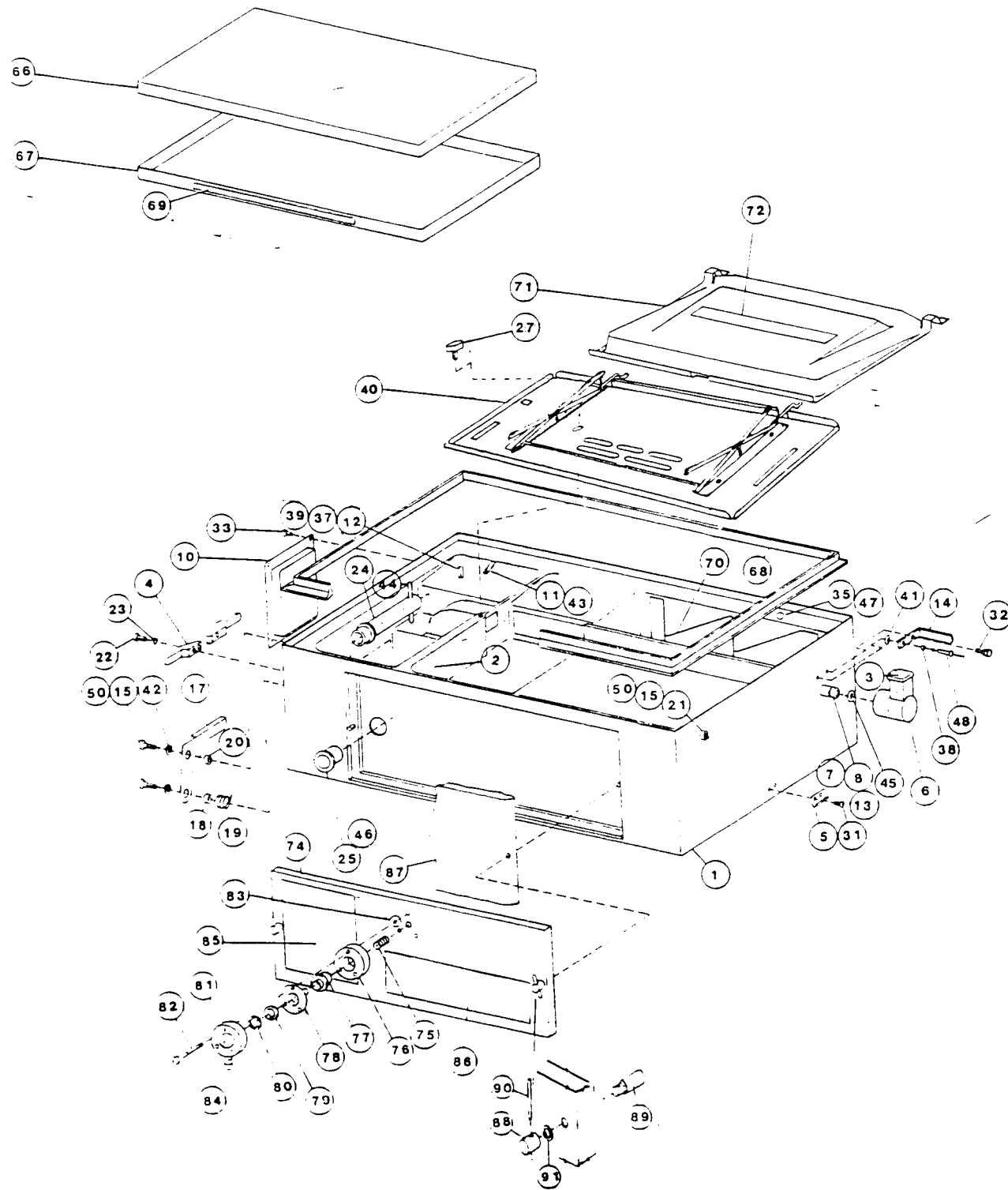

FIGURE 6.6 PARTS LOCATION DIAGRAM, SHELL AND DECK ASSEMBLY, GROUP 1

ITEM NO.	REFERENCE DESIG.	DESCRIPTION	PART NUMBER
1		SHELL	68 507 00
2		CASTING	26 100 30
3		FILLER PIPE CAP	12 209 01
4		CABLE HOOK	68 604 30
5		LATCH HOOK	24 144 01
6		HUMIDITY CHAMBER FILL SPOUT	26 200 02
7		SEALING WASHER	26 204 00
8		SEALING PIVOT NUT	26 205 00
9		NOT USED	
10		RECESSED OUTLET PANEL (BLANK)	68 500 15
		RECESSED OUTLET PANEL LABEL - C400, 120V ENG	68 523 40
		RECESSED OUTLET PANEL LABEL - C400, 120V SPN	68 523 41
		RECESSED OUTLET PANEL LABEL - C400, 240V ENG	68 523 43
		RECESSED OUTLET PANEL LABEL - C400, 220V SPN	68 523 44
		RECESSED OUTLET PANEL LABEL - C450, 120V ENG	68 525 20
		RECESSED OUTLET PANEL LABEL - C450, 120V SPN	68 525 21
		RECESSED OUTLET PANEL LABEL - C450, 240V ENG	68 525 30
		RECESSED OUTLET PANEL LABEL - C450, 220V SPN	68 525 31
11		GROUNDING SPRING	68 110 41
12		RAMP LATCH	68 110 42
13		HUMIDITY CHAMBER PIPE	68 110 43
14		FILL SPOUT STOP	68 110 50
15		SLOTTED SHOULDER SCREW	68 110 51
16		NOT USED	
17		LATCH HANDLE	68 110 55
18		SPACER NON-METALLIC	68 110 56
19		TORSION SPRING	68 110 57
20		SPACER NON-METALLIC	68 110 58
21		SPACER NON-METALLIC	68 110 59
22		SCREW, 4 - 40 X 5/16 TR PH SS	99 010 76
23		LOCK WASHER, EXT #4	99 121 37
24		CROSS FEED PIPE	68 112 05
25		FILTER GROMMET	68 112 15
26		NOT USED	
27		DECK RETAINING KNOB REPL KIT	68 901 22
28		NOT USED	
29		NOT USED	
30		NOT USED	
31		SCREW, 4 - 40 X 5/16 FL PH SS	99 010 77
32		THUMB SCREW, 4 - 40 X 1/4	99 010 63
33		SCREW, 4 - 40 X 5/16 TR PH SS	99 010 76
34		NOT USED	

TABLE 6.6 SHELL AND DECK ASSEMBLY, GROUP 1, PARTS LIST

(SHEET 2 OF 3)

ITEM NO.	REFERENCE DESIG.	DESCRIPTION	PART NUMBER
35		SCREW, 8 - 32 X 3/8 RD PH SS	99 031 37
36		NOT USED	
37		HEX NUT, 8 - 32 SS	99 106 01
38		SPACER, 0.250 OD X 0.40 ID X 0.25 THK	99 121 96
39		LOCK WASHER, #8	99 122 95
40		MAIN DECK MANUAL TILT (REFER TO TABLE 6.7)	68 521 70
41		WASHER, 0.560 OD X 0.25 ID PLASTIC	99 125 57
42		WASHER, 0.38 OD X 0.62 ID	99 126 70
43		HEX NUT, 6 - 32 KEPS	99 105 34
44		PIN, 1/8 DIA X 1 1/2 LG SS	99 143 96
45		O-RING 5/8 X 3/4 X 1/16	99 161 04
46		DOW CORNING LUBE #111	AR
47		WHITE RTV COMPOUND	AR
48		POP RIVET, 1/8 LARGE FLANGE	99 131 70
49		NOT USED	
50		LOCTITE #222	AR
51		NOT USED	
52		NOT USED	
53		NOT USED	
54		NOT USED	
55		NOT USED	
56		NOT USED	
63		NOT USED	
64		REDUCER BUSHING, 1/4 NPT X 1/8 FNPT	68 504 09
65		NOT USED	
66		MATTRESS	68 142 71
67		MATTRESS TRAY ASSY ENG (INCLUDES ITEM 69)	68 901 40
		MATTRESS TRAY ASSY SPN	68 901 41
68		HOOD GASKET	12 216 00
69		MATTRESS TRAY WARNING LABEL ENG	68 160 30
69		MATTRESS TRAY WARNING LABEL SPN	68 160 31
70		HUMIDITY BAFFLE	26 101 02
71		PLENUM ASSEMBLY (INCLUDES ITEM 72)	68 901 21
72		PLENUM LABEL	68 141 26
73		NOT USED	
74		FILTER COVER ASSEMBLY, ENG (INCLUDES ITEM 75 THRU 88)	68 507 40
		FILTER COVER ASSEMBLY, SPN (INCLUDES ITEM 75 THRU 88)	68 507 41
75		COMPRESSION SPRING	68 130 65
76		CYLINDER	68 130 55
77		FILTER CARTRIDGE	68 130 67

TABLE 6.6 SHELL AND DECK ASSEMBLY, GROUP 1, PARTS LIST

(SHEET 3 OF 3)

ITEM NO.	REFERENCE DESIG.	DESCRIPTION	PART NUMBER
78		DIAPHRAGM	68 130 57
79		NON-METALLIC WASHER	68 130 51
80		RETAINING RING, WAL 5105-62 SS	99 182 93
81		CAP	68 130 60
82		SCREW, 6 - 32 X 1.75" OV PH SS	99 026 18
83		NON-METALLIC WASHER	68 130 52
84		OXYGEN LIMITER LABEL, ENG	68 133 35
		OXYGEN LIMITER LABEL, SPN	68 133 36
85		OXYGEN CONCENTRATION LABEL, ENG	68 133 10
		OXYGEN CONCENTRATION LABEL, SPN	68 133 11
86		FILTER COVER LABEL, ENG	26 330 60
		FILTER COVER LABEL, SPN	26 330 61
87		AIR FILTER (BOX OF 4)	26 945 70
88		FILTER COVER KNOB	68 130 30
89		FILTER COVER KNOB SHAFT	68 130 35
90		FILTER COVER KNOB HANDLE	68 130 40
91		WASHER, 0.38 ID X 0.62 OD X 0.15 THK NYLON	99 126 11

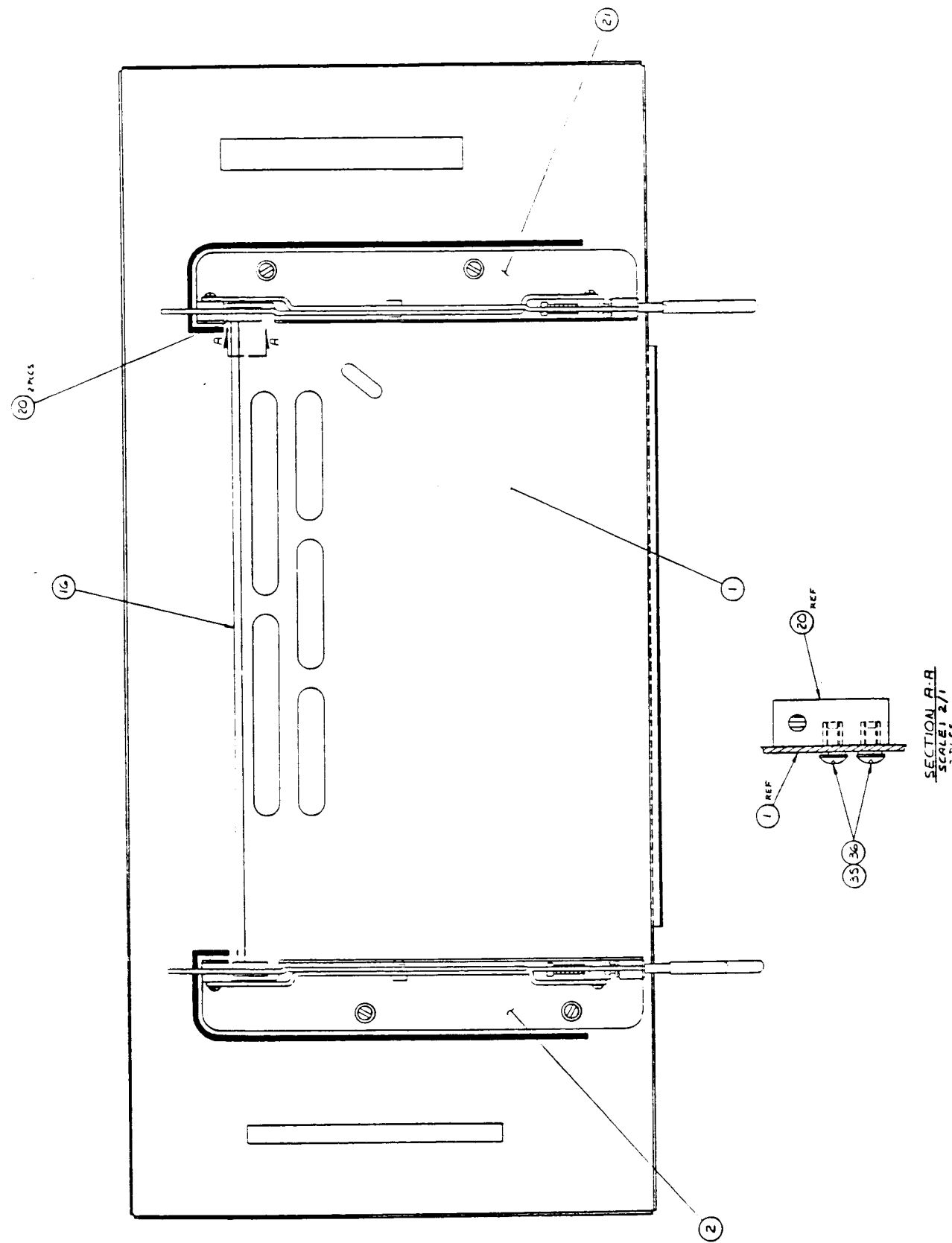

FIGURE 6.7 PARTS LOCATION DIAGRAM, MANUAL TILT DECK ASSEMBLY, GROUP 1

TABLE 6.7 MANUAL TILT DECK ASSEMBLY, GROUP 1, PARTS LIST

(SHEET 1 OF 1)

ITEM NO.	REFERENCE DESIG.	DESCRIPTION	PART NUMBER
1		MAIN DECK	68 504 41
2		ELEVATOR ASSEMBLY, LEFT HAND, ENG	68 907 06
		ELEVATOR ASSEMBLY, LEFT HAND, SPN	68 907 07
3		ELEVATOR ASSEMBLY, RIGHT HAND, ENG	68 907 00
		ELEVATOR ASSEMBLY, RIGHT HAND, SPN	68 907 01
4		PLENUM SHAFT	68 141 36
5		PLENUM PIVOT ROD	68 521 45
6		SCREW, 6 - 32 X 5/16 TR PH SS	99 022 98
7		LOCK WASHER NO. 6 SP SS	99 122 16

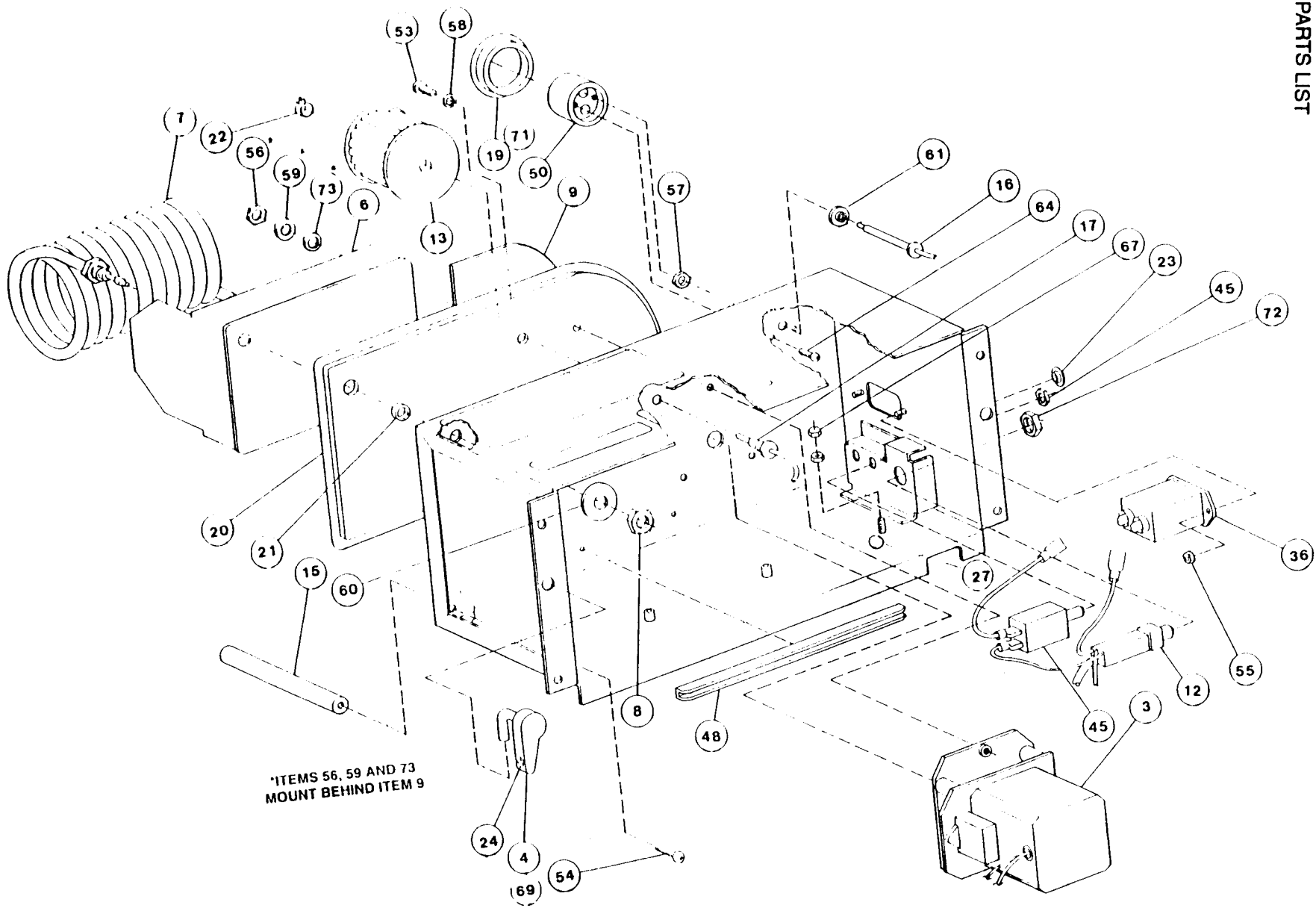

FIGURE 6.8 PARTS LOCATION DIAGRAM, CONTROLLER ASSY, GROUP 1
(Sheet 1 of 3)

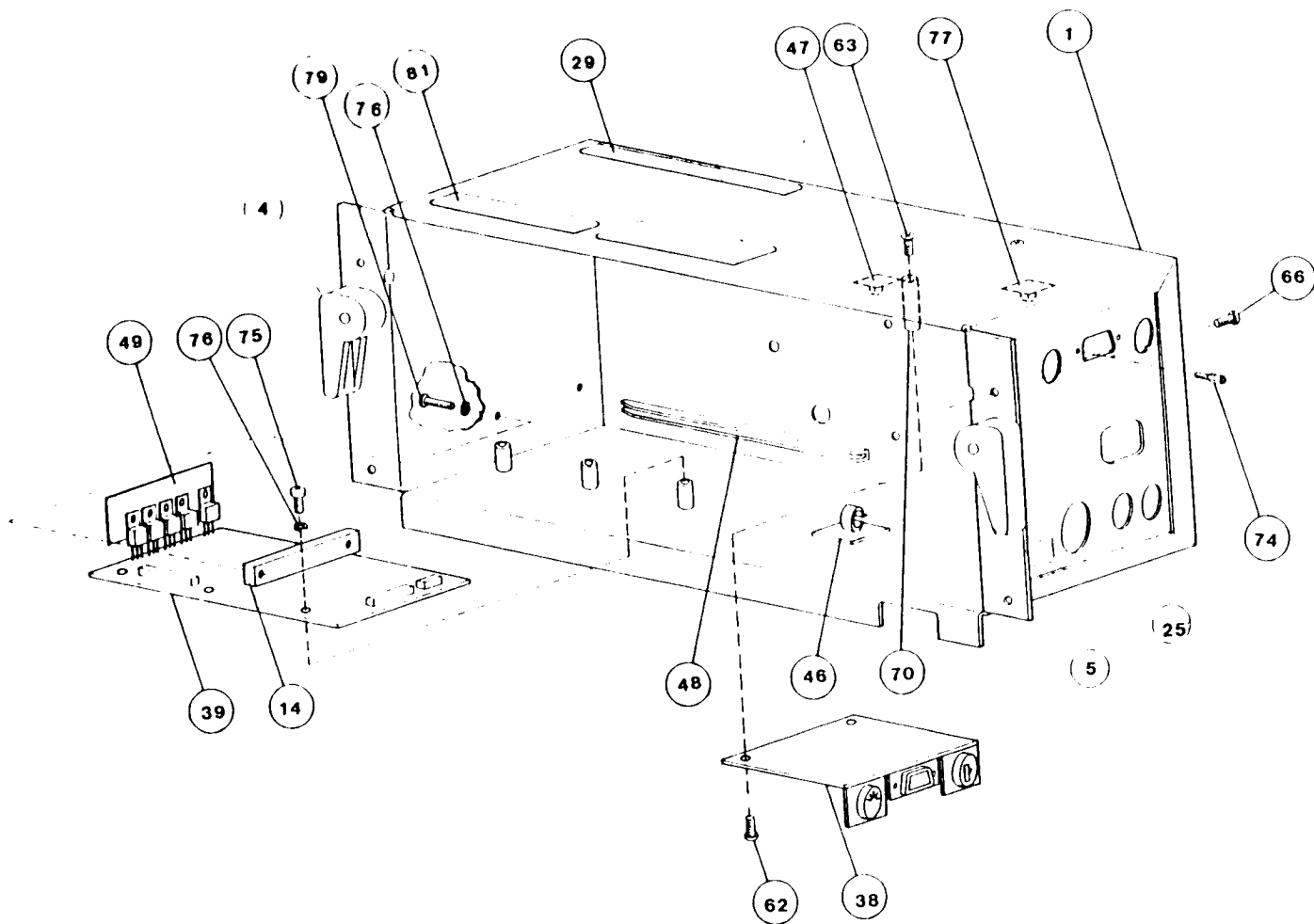

FIGURE 6.8 PARTS LOCATION DIAGRAM, CONTROLLER ASSY, GROUP 1
(Sheet 2 of 3)

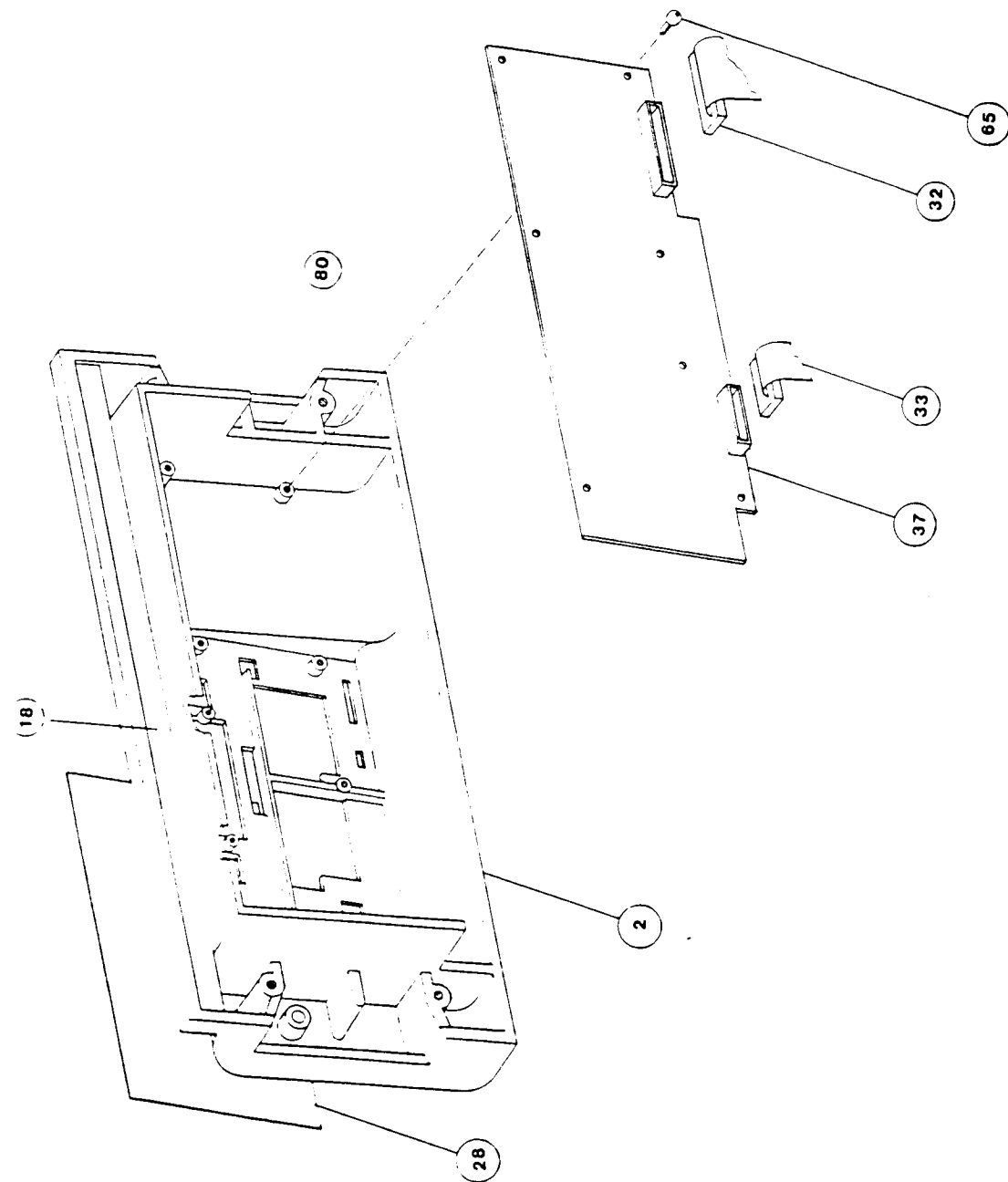

FIGURE 6.8 PARTS LOCATION DIAGRAM, CONTROLLER ASSY, GROUP 1
(Sheet 3 of 3)

TABLE 6.8 CONTROLLER ASSEMBLY, GROUP 1, PARTS LIST

(SHEET 1 OF 3)

ITEM NO.	REFERENCE DESIG.	DESCRIPTION	PART NUMBER
		CONTROLLER, C400 120V ENGLISH	68 252 70
		CONTROLLER, C400 120V SPANISH	68 252 71
		CONTROLLER, C400 240V ENGLISH	68 252 80
		CONTROLLER, C400 220V SPANISH	68 252 81
		CONTROLLER, C450 120V ENGLISH	68 252 70
		CONTROLLER, C450 120V SPANISH	68 252 71
		CONTROLLER, C450 240V ENGLISH	68 252 80
		CONTROLLER, C450 220V SPANISH	68 252 81
1		CONTROLLER CHASSIS	68 250 00
2		CONTROLLER HOUSING	68 250 01
3		MOTOR ASSEMBLY, 120V	68 205 16
		MOTOR ASSEMBLY, 220-240V	68 205 17
4		LEFT LATCH ASSEMBLY	68 230 10
5		RIGHT LATCH ASSEMBLY	68 230 11
6		HEATER BAFFLE PLATE	68 208 20
7		HEATER COIL, 120V	68 208 25
		HEATER COIL, 240V	68 208 26
8		HEATER ASSEMBLY NUT	99 105 70
9		STIFFENER PLATE	68 204 21
10		NOT USED	
11		NOT USED	
12		POWER SWITCH ASSEMBLY	68 250 15
13		IMPELLER, 0.250 ID X 2.95 OD X 2.61 WIDE	68 205 41
14		REGULATOR SUPPORT	68 250 02
15		BUMPER POST	68 215 12
16		DUAL THERMISTOR ASSEMBLY, BLUE	68 214 84
17		AIR FLOW THERMISTOR ASSEMBLY	68 214 84
18		GASKET, PVC, FM SLFADH, 18.00 X 0.50 X 0.12 THK	68 230 09
19		GASKET, 1.75 ID X 2.62 OD	26 501 00
20		POWER PACK GASKET	26 503 00
21		SPACER, 0.441 ID X 0.560 OD X 0.12 LF DELRAN	26 516 05
22		HOSE CLAMP	20 015 65
23		PLUG BUTTON, 0.75 HOLE (120V UNITS ONLY)	22 035 40
24		MANUAL REFERENCE LABEL	68 160 05
25		VOLTAGE LABEL, 120 VAC	68 204 40
		VOLTAGE LABEL, 240 VAC	68 204 41
		VOLTAGE LABEL, 240 VAC	68 204 44
26		NOT USED	
27		GROUND SYMBOL LABEL	68 212 05
28		FRONT PANEL OVER LAY, C400 ENGLISH	68 524 00
		FRONT PANEL OVERLAY, C400 SPANISH	68 524 01
		FRONT PANEL OVERLAY, C450 ENGLISH	68 524 03
		FRONT PANEL OVERLAY, C450 SPANISH	68 524 04

TABLE 6.8 CONTROLLER ASSEMBLY, GROUP 1, PARTS LIST,

(SHEET 2 OF 3)

ITEM NO.	REFERENCE DESIG.	DESCRIPTION	PART NUMBER
29		HOT HEATER WARNING LABEL ENGLISH	68 208 35
		HOT HEATER WARNING LABEL SPANISH	68 208 36
30		NOT USED	
31		CHASSIS STERILIZATION CAUTION LABEL ENGLISH	68 212 15
		CHASSIS STERILIZATION CAUTION LABEL SPANISH	68 212 16
32		RIBBON CABLE ASSY, PROBE BD TO DISPLAY BD	68 250 10
33		RIBBON CABLE ASSY, POWER SUPPLY TO DISPLAY BD	68 250 11
34		POWER INLET JUMPER, BLUE 220/240V UNITS ONLY	68 250 12
35		NOT USED	
36		AC RECEPTACLE/LINE/FILTER ASSY	68 250 18
37		DISPLAY PRINTED CIRCUIT BOARD ASSY C400	68 383 70
		DISPLAY PRINTED CIRCUIT BOARD ASSY C450	68 383 71
38		PROBE PRINTED CIRCUIT BOARD ASSY	68 382 70
39		POWER SUPPLY ASSEMBLY, 120V	68 381 70
		POWER SUPPLY ASSEMBLY, 240V	68 381 71
40		NOT USED	
41		NOT USED	
42		NOT USED	
43		NOT USED	
44		AC POWER CORD 120V	17 AZ 100
		AC POWER CORD 220/240V	17 AZ 200
45		THERMAL CIRCUIT BREAKER, 5.0A, 250V/28V 120V UNITS	17 BH 150
		THERMAL CIRCUIT BREAKER, 3.0A, 250V/28V 220V UNITS	17 BH 146
46		CORD RETAINING CLIP	17 725 44
47		WIRE CLIP, SELF-ADHESIVE, 3/8 BASE	17 725 70
48		PCB SUPPORT	17 062 80
49		THERMAL TRANSFER TAPE	17 062 83
50		THERMOSTAT PLUG	12 512 01
51		NOT USED	
52		NOT USED	
53		SCREW, 8 - 32 X 3/8 TR PH SS	99 031 38
54		SCREW, 10 - 32 X 1/2 TR PH SS NYLOK	99 042 05
55		HEX NUT, 4 - 40 KEPS S CA	99 103 33
56		HEX NUT, 3/8 - 24 BR NI THIN	99 111 80
57		HEX NUT, 15/32 - 32 0.25 THK DELRAN	68 215 11
58		LOCK WASHER, INT #8 SS	99 122 92
59		FLAT WASHER, 3/8 ID X 0.60 OD X 0.065 THK	99 126 70
60		LOCK WASHER, INT 7/16 S CA	99 127 41
61		SHOULDER WASHER, 0.501 ID X 0.750 OD X 0.09 FIBER	99 127 69
62		SCREW, 4 - 40 X 1/4 PN PH S Z1 SEMSC	99 010 66
63		SCREW, 4 - 40 X 1/4 FL PH SS	99 010 62
64		SCREW, 8 - 32 3/4 PN PH SS SEMS IN	99 032 94
65		SCREW, 6 - 32 X 3/8 PN PH S Z1 SEMSC	99 023 49
66		SCREW, 10 - 32 X 3/8 PN PH SS SEM EX	99 041 35

TABLE 6.8 CONTROLLER ASSEMBLY, GROUP 1, PARTS LIST

(SHEET 3 OF 3)

ITEM NO.	REFERENCE DESIG.	DESCRIPTION	PART NUMBER
67		HEX NUT, 6 - 32 KEPS S CA	99 105 34
68		NOT USED	
69		O-RING, 0.370 X 0.450 X 0.040 BUNA	99 160 55
70		STAND-OFF, 4 - 40 ID X 1.19 LG NYLON	99 116 47
71		SEALANT, SYNTHETIC RUBBER, 3M 800	AR
72		HEX NUT, THIN, M14 X 1.0 X 0.2 THK BR	17 061 91
73		SHOULDER WASHER, 0.381 ID X 0.620 OD X 0.06, FIBER	17 803 40
74		FEMALE SCREW LOCK ASSEMBLY	505C0002202
75		SCREW, 4 - 40 X 7/16 TR PH SS	99 011 35
76		LOCK WASHER, INT #4 SS	99 121 35
77		WIRE, CLIP, SELF ADHESIVE, 1-INCH BASE	17 725 71
78		POWER INLET JUMPER, BROWN	68 250 13
79		SCREW, 4 - 40 X 9/16 TR PH SS	99 011 75
80		BEZEL COVER, SELF-ADHESIVE	68 250 05
81		NON INTERCHANGEABLE LABEL	68 525 08
82		NOT USED	
83		NOT USED	
84		LOCTITE SCREWLOCK, NO. 222	AR

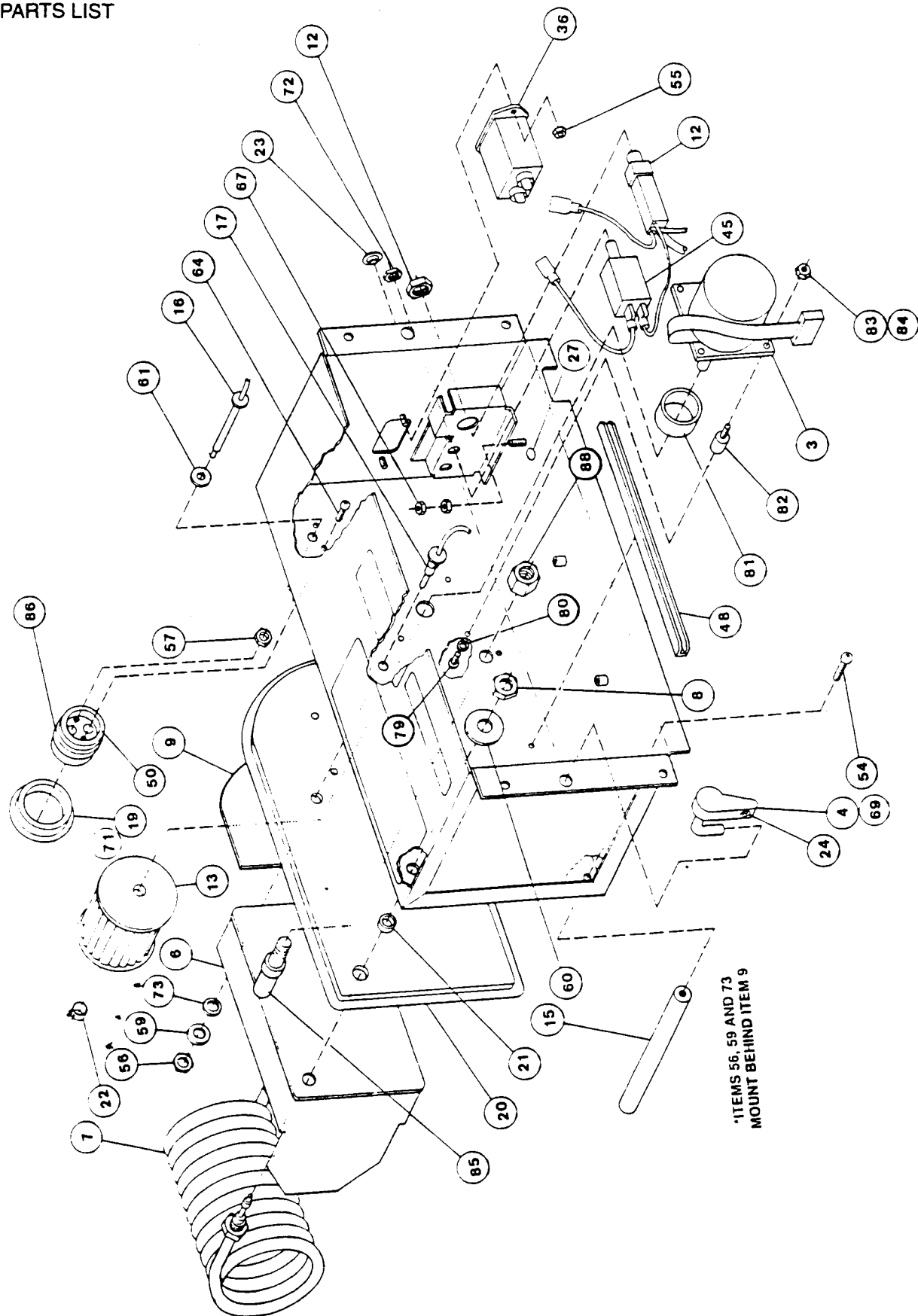

FIGURE 6.9 PARTS LOCATION DIAGRAM, CONTROLLER ASSY, GROUP 2
(Sheet 1 of 3)

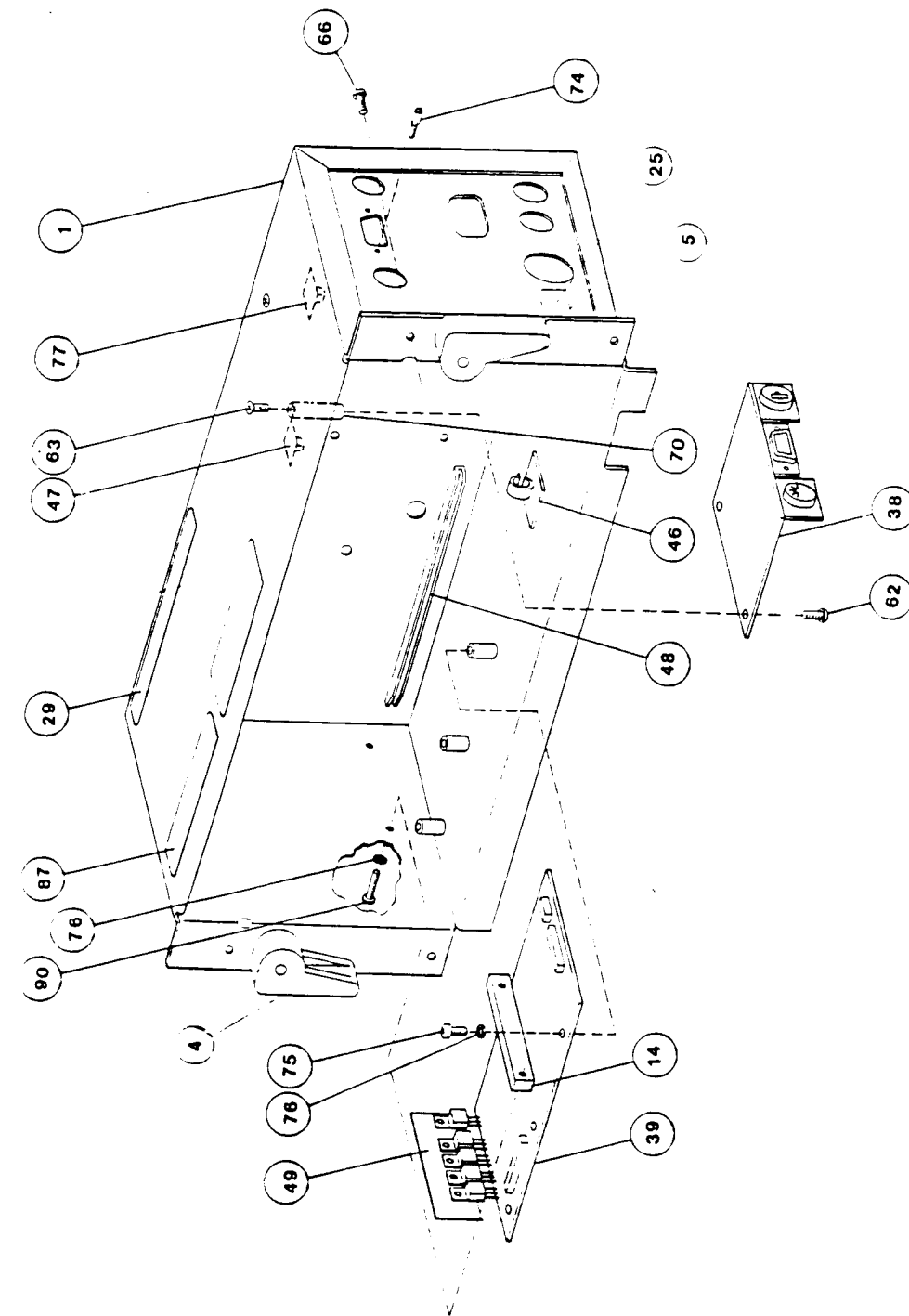

FIGURE 6.9 PARTS LOCATION DIAGRAM, CONTROLLER ASSY, GROUP 2
(Sheet 2 of 3)

TABLE 6.9 CONTROLLER ASSEMBLY, GROUP 2, PARTS LIST

(SHEET 1 OF 3)

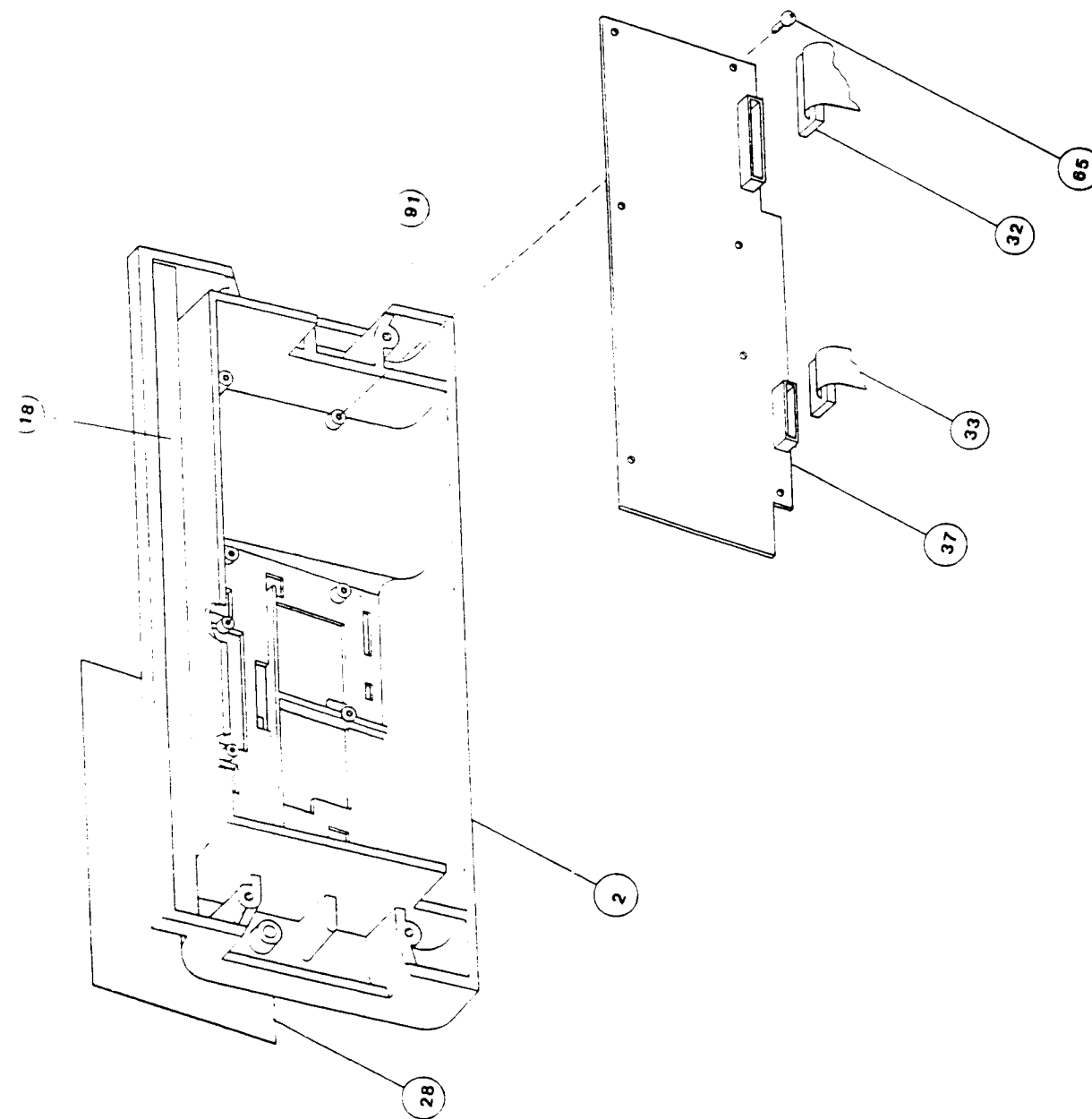

FIGURE 6.9 PARTS LOCATION DIAGRAM, CONTROLLER ASSY, GROUP 2
(Sheet 3 of 3)

ITEM NO.	REFERENCE DESIG.	DESCRIPTION	PART NUMBER
		CONTROLLER, C400 120V ENGLISH	68 253 70
		CONTROLLER, C400 120V SPANISH	68 253 71
		CONTROLLER, C400 120V FRENCH	68 253 72
		CONTROLLER, C400 220/240V ENGLISH	68 253 80
		CONTROLLER, C400 220/240V SPANISH	68 253 81
		CONTROLLER, C400 220/240V FRENCH	68 253 82
		CONTROLLER, C400 220V GERMAN	68 253 83
		CONTROLLER, C400 220/240V ITALIAN	68 253 84
		CONTROLLER, C450 120V ENGLISH	68 254 70
		CONTROLLER, C450 120V SPANISH	68 254 71
		CONTROLLER, C450 120V FRENCH	68 254 72
		CONTROLLER, C450 220/240V ENGLISH	68 254 80
		CONTROLLER, C450 220/240V SPANISH	68 254 81
		CONTROLLER, C450 220/240V FRENCH	68 254 82
		CONTROLLER, C450 220V GERMAN	68 254 83
		CONTROLLER, C450 220/240V ITALIAN	68 254 84
1		CONTROLLER CHASSIS	68 250 00
2		CONTROLLER HOUSING	68 250 01
3		MOTOR ASSEMBLY, 24 VDC	68 230 20
4		LEFT LATCH ASSEMBLY	68 230 10
5		RIGHT LATCH ASSEMBLY	68 230 11
6		HEATER BAFFLE PLATE	68 208 20
7		HEATER COIL, 120V	68 208 25
		HEATER COIL, 240V	68 208 26
8		HEATER ASSEMBLY NUT	99 105 70
9		STIFFENER PLATE	68 204 21
10		NOT USED	
11		NOT USED	
12		POWER SWITCH ASSEMBLY	68 250 15
13		IMPELLER, 0.250 ID X 2.95 OD X 2.61 WIDE	68 205 41
14		REGULATOR SUPPORT	68 250 02
15		BUMPER POST	68 215 12
16		DUAL THERMISTOR ASSEMBLY, BLUE	68 214 84
17		AIR FLOW THERMISTOR ASSEMBLY	68 214 84
18		GASKET, PVC, FM SLFADH, 18.00 X 0.50 X 0.12 THK	68 230 09
19		GASKET, 1.75 ID X 2.62 OD	26 501 00
20		POWER PACK GASKET	26 503 00
21		SPACER, 0.441 ID X 0.560 OD X 0.12 LF DELRAN	26 516 05
22		HOSE CLAMP	20 015 65
23		PLUG BUTTON, 0.75 HOLE (120V UNITS ONLY)	22 035 40
24		MANUAL REFERENCE LABEL	68 160 05

TABLE 6.9 CONTROLLER ASSEMBLY, GROUP 2, PARTS LIST,

(SHEET 2 OF 3)

ITEM NO.	REFERENCE DESIG.	DESCRIPTION	PART NUMBER
25		VOLTAGE LABEL, 120 VAC	68 204 40
		VOLTAGE LABEL, 240 VAC	68 204 41
		VOLTAGE LABEL, 220 VAC	68 204 43
		VOLTAGE LABEL, 220-240 VAC	68 204 44
26		NOT USED	
27		GROUND SYMBOL LABEL	68 212 05
28		FRONT PANEL OVERLAY, C400 ENGLISH	68 524 00
		FRONT PANEL OVERLAY, C400 SPANISH	68 524 01
		FRONT PANEL OVERLAY, C400 FRENCH	68 524 02
		FRONT PANEL OVERLAY, C400 GERMAN	68 524 03
		FRONT PANEL OVERLAY, C400 ITALIAN	68 524 04
		FRONT PANEL OVER LAY, C400 ENGLISH	68 525 03
		FRONT PANEL OVERLAY, C400 SPANISH	68 525 04
		FRONT PANEL OVERLAY, C400 FRENCH	68 525 05
		FRONT PANEL OVERLAY, C400 GERMAN	68 525 06
		FRONT PANEL OVERLAY, C400 ITALIAN	68 526 07
29		HOT HEATER WARNING LABEL ENGLISH	68 208 35
		HOT HEATER WARNING LABEL FRENCH	68 208 37
		HOT HEATER WARNING LABEL ITALIAN	68 208 38
		HOT HEATER WARNING LABEL GERMAN	
30		NOT USED	
31		CHASSIS STERILIZATION CAUTION LABEL ENGLISH	68 212 15
		CHASSIS STERILIZATION CAUTION LABEL SPANISH	68 212 16
		CHASSIS STERILIZATION CAUTION LABEL FRENCH	68 212 17
		CHASSIS STERILIZATION CAUTION LABEL GERMAN	68 212 18
		CHASSIS STERILIZATION CAUTION LABEL ITALIAN	68 212 20
32		RIBBON CABLE ASSY, PROBE BD TO DISPLAY BD	68 250 10
33		RIBBON CABLE ASSY, POWER SUPPLY TO DISPLAY BD	68 250 11
34		POWER INLET JUMPER, BLUE 220/240V UNITS ONLY	68 250 12
36		AC RECEPTACLE/FILTER ASSY	68 250 18
37		MAIN/DISPLAY BOARD C400 GROUP 2	68 383 72
		MAIN/DISPLAY BOARD C450 GROUP 2	68 383 73
		MAIN/DISPLAY BOARD C400 GROUP 2 US	68 383 74
		MAIN/DISPLAY BOARD C450 GROUP 2 US	68 383 75
38		PROBE PRINTED CIRCUIT BOARD ASSY	68 382 70
39		POWER SUPPLY ASSEMBLY, 120V	68 381 70
		POWER SUPPLY ASSEMBLY, 240V	68 381 71
44		AC POWER CORD 120V	17 AZ 100
		AC POWER CORD 220/240V	17 AZ 200
45		THERMAL CIRCUIT BREAKER, 5.0A, 250V/28V 120V UNITS	17 BH 150
		THERMAL CIRCUIT BREAKER, 3.0A, 250V/28V 220V UNITS	17 BH 146
46		CORD RETAINING CLIP	17 725 44

TABLE 6.9 CONTROLLER ASSEMBLY, GROUP 2, PARTS LIST

(SHEET 3 OF 3)

ITEM NO.	REFERENCE DESIG.	DESCRIPTION	PART NUMBER
47		WIRE CLIP, SELF-ADHESIVE, 3/8 BASE	17 725 70
48		PCB SUPPORT	17 062 80
49		THERMAL TRANSFER TAPE	17 062 83
50		THERMOSTAT PLUG	12 512 01
52		NOT USED	
53		NOT USED	
54		SCREW, 10 - 32 X 1/2 TR PH SS NYLOK	99 042 05
55		HEX NUT, 4 - 40 KEPS S CA	99 103 33
56		HEX NUT, 3/8 - 24 BR NI THIN	99 111 80
57		HEX NUT, 15/32 - 32 0.25 THK DELRAN	68 215 11
58		NOT USED	
59		FLAT WASHER, 3/8 ID X 0.60 OD X 0.065 THK	99 126 70
60		LOCK WASHER, INT 7/16 S CA	99 127 41
61		SHOULDER WASHER, 0.501 ID X 0.750 OD X 0.09 FIBER	99 127 69
62		SCREW, 4 - 40 X 1/4 PN PH S Z1 SEMSC	99 010 66
63		SCREW, 4 - 40 X 1/4 FL PH SS	99 010 62
64		SCREW, 8 - 32 3/4 PN PH SS SEMS IN	99 032 94
65		SCREW, 6 - 32 X 3/8 PN PH S Z1 SEMSC	99 023 49
66		SCREW, 10 - 32 X 3/8 PN PH SS SEM EX	99 041 35
67		HEX NUT, 6 - 32 KEPS S CA	99 105 34
68		NOT USED	
69		O-RING, 0.370 X 0.450 X 0.040 BUNA	99 160 55
70		STAND-OFF, 4 - 40 ID X 1.19 LG NYLON	99 116 47
71		SEALANT, SYNTHETIC RUBBER, 3M 800	AR
72		HEX NUT, THIN, M14 X 1.0 X 0.2 THK BR	17 061 91
73		SHOULDER WASHER, 0.381 ID X 0.620 OD X 0.06, FIBER	17 803 40
74		FEMALE SCREW LOCK ASSEMBLY	505C0002202
75		SCREW, 4 - 40 X 7/16 TR PH SS	99 011 35
76		LOCK WASHER, INT #4 SS	99 121 35
77		WIRE, CLIP, SELF ADHESIVE, 1-INCH BASE	17 725 71
78		POWER INLET JUMPER, BROWN	68 250 13
79		SCREW, 8 - 32 X 1/4 TR PH SS	99 030 69
80		LOCK WASHER, INT #8 SS	99 122 92
81		MOTOR SHAFT SEAL, NEOPREEN 0.751 ID X 1.25 OD	68 230 27
82		VIBRATION ISOLATOR, 0.44 OD X 0.44 LG 4LB	68 230 24
83		HEX NUT, 8 - 32 KEPS S Z1	99 106 32
84		LOCTITE SCREWLOCK, NO. 222	AR
85		CONTROLLER LOCATING PIN	68 233 02
86		THERMAL PLUG ALIGNMENT SLEEVE	68 233 03
87		NON-INTERCHANGEABLE LABEL	68 525 08
88		HEX NUT, 3/8 - 16 ES S Z1	99 111 25
89		ADHESIVE, LOCTITE 404 OR EASTMAN 910	AR
90		SCREW, 4 - 40 X 9/16 TR PH SS	99 011 75
91		BEZEL COVER, SELF ADHESIVE	68 250 05

TABLE 6.10 MAIN/DISPLAY BOARD, PARTS LIST

(SHEET 1 OF 3)

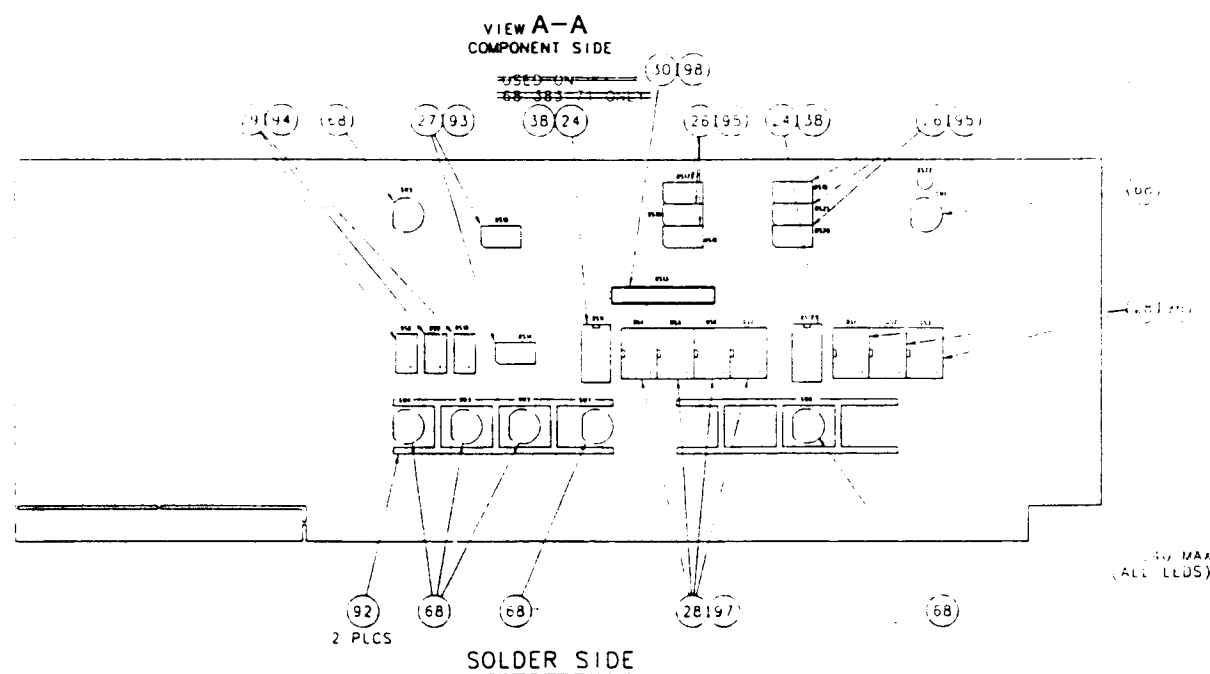
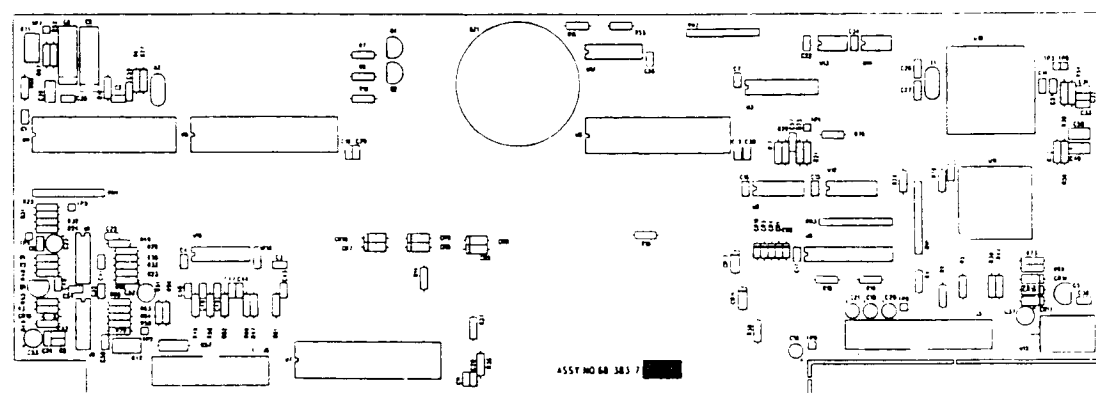

FIGURE 6.10 PARTS LOCATION DIAGRAM, MAIN/DISPLAY BOARD

ITEM NO.	REFERENCE DESIG.	DESCRIPTION	PART NUMBER
-		MAIN/DISPLAY BOARD C400 GROUP 1	68 383 70
-		MAIN/DISPLAY BOARD C450 GROUP 1	68 383 71
-		MAIN/DISPLAY BOARD C400 GROUP 2	68 383 72
-		MAIN/DISPLAY BOARD C450 GROUP 2	68 383 73
-		MAIN/DISPLAY BOARD C400 GROUP 2 US	68 383 74
-		MAIN/DISPLAY BOARD C450 GROUP 2 US	68 383 75
1		NOT USED	
2		NOT USED	
3		NOT USED	
4		NOT USED	
5		NOT USED	
6		NOT USED	
7		NOT USED	
8		NOT USED	
9		NOT USED	
10	CR1,2,3,4,16	DIODE, 1N914	17 AR 500
11	CR5 THRU 12, 14, 15, 17	DIODE, 1N4001	17 AS 000
12	CR18	DIODE, ZENER 5.1 V 5%, 0.5W	17 502 50
13		NOT USED	
14	C57	CAP., 0.1 μ F	17 AY 646
15	C26, 27	CAP., 27 pF, 2% 500V, TC, CER RDL	17 AW 101
16	C23,37,52,53	CAP., 10 μ F, 10% 25V, TANT	17 AW 236
17	C18 THRU 21	CAP., 47 μ F, 20%, 25V, AL SE	17 AW 775
18	C28,29,30,40,41	CAP., 1000 pF, 20% 50V, ML CER	17 BF 202
19	C1 THRU 7, C10 THRU 17,22,24,25,31, 32,33,34,35,36,38,42, 43,44,45,48,51,54,56, 58	CAP., 0.1 μ F, 20%, 50V, ML CER	17 BF 217
20	C39,50	CAP., 1.0 μ F, 20%, 50V, NML CER	17 BF 224
21	C8	CAP., 0.15 μ F, 250V, POLYPROP, FILM	17 405 85
22	C9	CAP., 0.33 μ F, 250V, POLYPROP, FILM	17 405 86
23		NOT USED	
24	DS11, 12	LAMP, LED, RECT, 16D DIP GREEN	17 BE 240
25		NOT USED	
26	DS16 THRU 21	LAMP, LED RECT, RED	17 807 00
27	DS14, 15	LAMP, LED RECT YELLOW	17 807 64
28	DS1 THRU 7	DISPLAY, LED 7 SEG, YELLOW	17 808 19
29	DS8, 9, 10	DISPLAY, LED, 7 SEG, GREEN	17 808 20
30	DS13	DISPLAY, LED, 5 SEG, YELLOW	17 808 25
31		NOT USED	
32	Q5	TRANS., PNP, 2N4403	17 627 46
33	Q1, 2, 4	TRANS., N-CHAN, POWER FET, VN10KM	17 627 94
34		NOT USED	

TABLE 6.10 MAIN/DISPLAY BOARD, PARTS LIST

(SHEET 2 OF 3)

ITEM NO.	REFERENCE DESIG.	DESCRIPTION	PART NUMBER
35	J6	CONNECTOR, PC HEADER DBL ROW 26 POSN	17 BR 624
36	J5	CONNECTOR, PC HEADER DBL ROW 34 POSN	17 BR 625
37		NOT USED	
38	DS11, 12	SOCKET, IC 16 PIN LOW PROFILE C450, C450 IEC AND C450 IEC US ONLY	17 062 84
39	XU4	SOCKET, IC PC MTG, 40 DIP	17 AP 198
40	XU11	SOCKET, PLCC, THRU HOLE, 44 POSN	17 BS 308
41	XU10	SOCKET, PLCC 68 PIN SQ THRU HOLE	17 BS 310
42	XU6	SOCKET, IC 24 DIP, 0.300 CTR	17 734 26
43	R57	RES., CRBN FILM, 120 Ω , 5% 1/2W C400/C450 ONLY	17 AB 657
44	R56, 70, 78	RES., 10.0 Ω , 1% 1/8W FILM	17 AF 000
45	R13, 15	RES., 56.2 Ω , 1% 1/8W FILM	17 AF 072
46	R44, 52	RES., 422.0 K, 1% 1/8W FILM	17 AF 156
47	R45	RES., 1.30 K, 1% 1/8W FILM	17 AF 203
48	R3	RES., 2.49 K, 1% 1/8W FILM	17 AF 230
49	R6,20,21,24,25,28, 30,39,54,67	RES., 3.01 K, 1% 1/8W FILM	17 AF 238
50	R33	RES., 5.36 K, 1%, 1/8W FILM	17 AF 262
51	R2,4,5,23,32,49,51	RES., 10 K, 1%, 1/8W FILM	17 AF 288
52	R35,65,66	RES., 10.2 K, 1% 1/8W FILM	17 AF 289
53	R36,37,38	RES., 22.1 K, 1% 1/8W FILM	17 AF 321
54	R17,18,19,26,73	RES., 24.9 K, 1% 1/8W FILM	17 AF 236
55	R9	RES., 30.1 K, 15 1/8w FILM	17 AF 334
56	R48	RES., 31.6 K, 1% 1/8W FILM	17 AF 336
57	R16	RES., 60.4 K, 1% 1/8W FILM	17 AF 363
58	R11,50,53	RES., 84.5 K, 1% 1/8W FILM	17 AF 377
59	R29	RES., 133 K, 1% 1/8W FILM	17 AF 396
60	R1, 31	RES., 1.00M, 1% 1/8W FILM	17 AF 480
61	RT1, 2	RES., VAR, 2 K, 0.5W, PCB VRT ADJ	17 AN 123
62	R53,61,75,76	RES., 4.32 K, MTL FILM, 0.1% 1/8W	17 AN 312
63	R46,47,58,59,60, 62,63,64	RES., 33.2 K, MTL FILM, 0.1% 1/10W	17 AN 350
64	RN1,2,3,4	RES. NTWK, 9 @ 10 K, 5% 1/8W SIP	17 AU 077
65	R68	JUMPER RES. BODY	17 217,62
66	R69	RES., 162 Ω , 1%, 1/8W FILM	17 AF 116
67		HEAT SINK, TO-220, COMPACT	17 062 81
68	SW1,2,3,4,5,6,7	SWITCH, PB, SPST, NO, 0.01A, 35 VDC SW6 AND 7 MOUNTED ON C450, C450 IEC C450 IEC US ONLY	17 682 47
69	R7,8,10	RES., 100 Ω , 1% 1/8W FILM	17 AF 096
70	U15	VOLTAGE REGULATOR, 5V, 1.5A, 7085AC	17 AT 060
71		NOT USED	
72	X2	CRYSTAL, 3.5793 MHZ	17 524 22
73	X1	CRYSTAL, 11.059 MHZ	17 524 23
74	U1	IC, QUAD COMPARATOR, 3302	17 629 58
75	U9	IC, QUAD COMPARATOR, 3403	17 629 70

TABLE 6.10 MAIN/DISPLAY BOARD, PARTS LIST

(SHEET 3 OF 3)

ITEM NO.	REFERENCE DESIG.	DESCRIPTION	PART NUMBER
76	U17	IC, CMOS, HEX INV BUFFER 4049	17 630 45
77	U16	IC, CMOS, ANLG MUX/DEMUX, 4051B	17 630 99
78	U12	IC, CMOS, 4 X 2 IN AND GATE, 78HC08	17 633 10
79	U2	IC, CMOS, HX SCHMIT TRIGGER, INV 74HC14	17 633 22
80	U3	IC, CMOS, OCT BUS XCVR, 74HCT245	17 633 24
81	U6	FIRMWARE, CONT, C400/C450 ALARM LOGIC	68 383 40
82	U13	IC, MICROMONITOR, 1232	17 633 64
83	U11	CONTROLLER FIRMWARE, C400/C450 IEC US	68 383 52
		CONTROLLER FIRMWARE, C400/C450 IEC	68 383 53
		CONTROLLER FIRMWARE, C400/C450	68 383 52
84		NOT USED	
85	U4	IC, CMOS 12 BIT BINARY A/D CONVERTER	17 633 85
86		NOT USED	
87	U5, 7, 8	LED DISPLAY DRIVER	17 633 87
88	U10	8 BIT MICROCONTROLLER 80C552	16 633 88
89	U14	IC, CMOS EPROM 1K SERIAL	17 633 89
90	BZ1	TRANSDUCER, AUDIO PIEZO, CER HI	17 652 96
91		NOT USED	
92		SWITCH GUARD	68 250 04
93		LED SPACER, 0.600 X 0.350 X 0.06	68 250 20
94		LED SPACER, 1.200 X 0.600 X 0.06	68 250 21
95		LED SPACER, 1.000 X 0.600 X 0.06	68 250 22
96		LED SPACER, 1.550 X 0.750 X 0.06	68 250 23
97		LED SPACER, 2.050 X 0.750 X 0.06	68 250 24
98		LED SPACER, 0.40 X 0.30 X .03	68 250 24

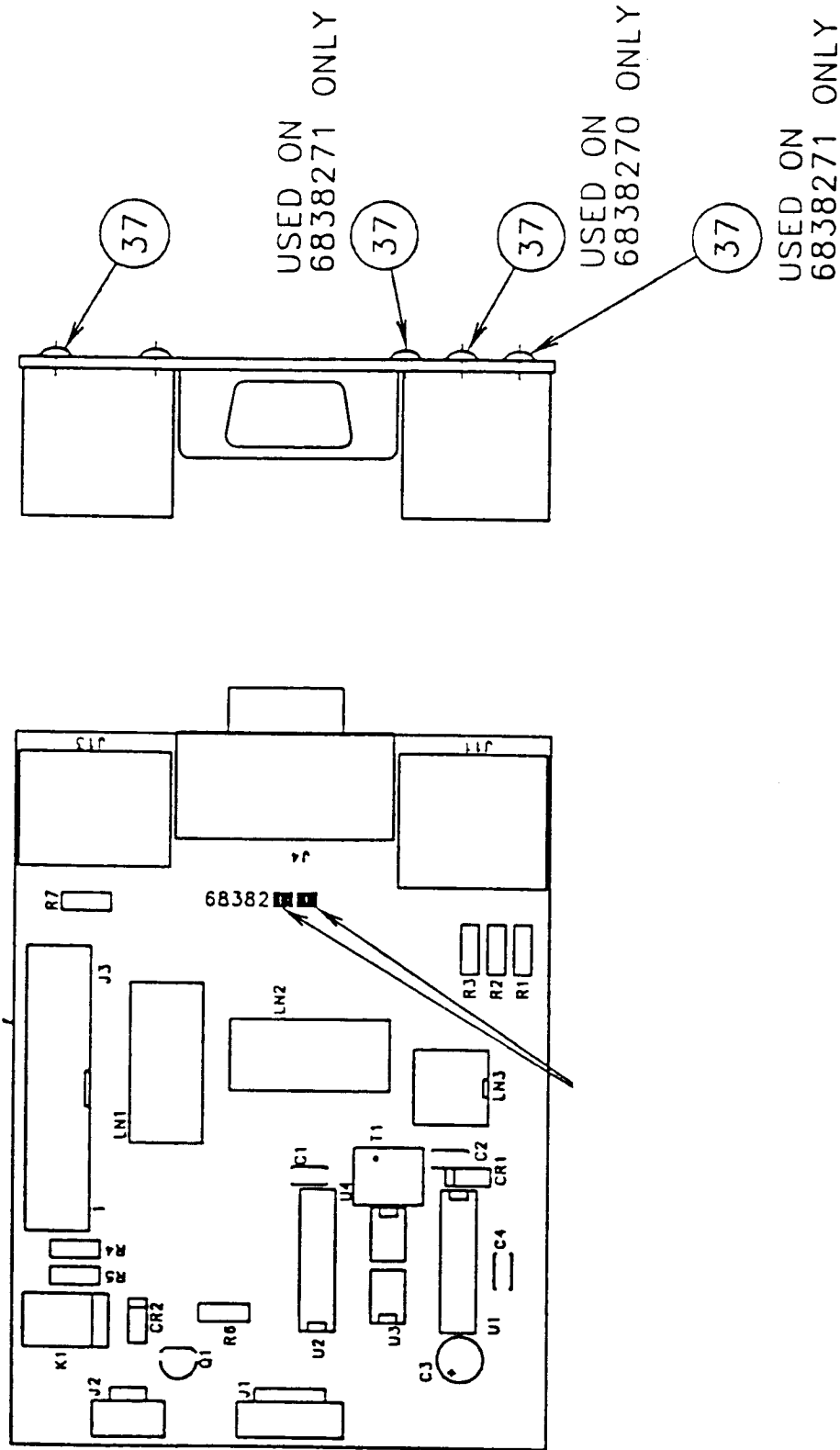

FIGURE 6.11 PARTS LOCATION DIAGRAM, PROBE BOARD

TABLE 6.11 PROBE BOARD, PARTS LIST

(SHEET 1 OF 1)

ITEM NO.	REFERENCE DESIG.	DESCRIPTION	PART NUMBER
-		PROBE BOARD, C400	68 382 70
-		PROBE BOARD, C450	68 382 71
1		NOT USED	
2		NOT USED	
3		NOT USED	
4		NOT USED	
5		NOT USED	
6		NOT USED	
7		NOT USED	
8		NOT USED	
9		NOT USED	
10		NOT USED	
11		NOT USED	
12	J3	CONN, PC HEADER, DBL ROW, 26 POSN	17 BR 624
13	J4	CONN, 3 PSN, PC HDR, PLZD, LCH SGL	17 BR 851
14	J1	CONN, 5 PSN, PC HDR, PLZD, LCH SGL	17 BR 853
15	J13	CONN, RCPT, FEM RTANG, PC 3 PSN	17 734 18
16	J11	CONN, RCPT, FEM RTANG, PC 6 PSN C450 ONLY	17 734 19
17	J11	CONN, RCPT, FEM RA PNL PC C400 ONLY	17 734 77
18	J4	CONN, D, HI-DEN, 15 POSN	17 734 86
19	LN3	INDUCTOR, 3 CKT, 6 DIP, EMI FILTER	17 585 53
20	LN1, 2	INDUCTOR, 8 CKT, 6 DIP, EMI FILTER	17 585 54
21		NOT USED	
22	R1, 2	JUMPER, RESISTOR BODY C450 ONLY	17 217 62
23	R3, 5	JUMPER, RESISTOR BODY C400 ONLY	17 217 62
24		SCREW, SELF TAPPING #2 X 5/16	99 081 32

THE FOLLOWING COMPONENTS ARE ON C450 ONLY

25	R4	RES., 43.00 K 0.05%, 1/20W METAL FILM	17 217 81
26	CR1, 2	DIODE, 1N914	17 AR 500
27	R6	RES., 100 K, 1% 1/8W FILM	17 AF 384
28	C3	CAP., 10 μF, 10%, 25V TANT	17 AW 236
29	C2, 3	CAP., 0.1 μF, 20%, 50V ML CER	17 BF 217
30	C1	CAP., 1.0 μF, 20%, 50V ML CER	17 BF 224
31	T1	ISOLATION TRANSFORMER PC MOUNT	17 605 49
32	U3,4	IC, OPTO-COUPLER, 4N35	17 633 26
33	U2	IC, ISOLATION, RS-232 DRVR/RCVR, 250	17 633 52
34	U1	IC, ISOLATION, RS-232 DRVR/RCVR, 251	17 633 53
35	Q1	TRANS., N-CHAN, POWER FET, VN10KM	17 627 94
36	K1	RELAY, HI S, SPDT, PC MOUNT, 5V COIL	17 BA 198

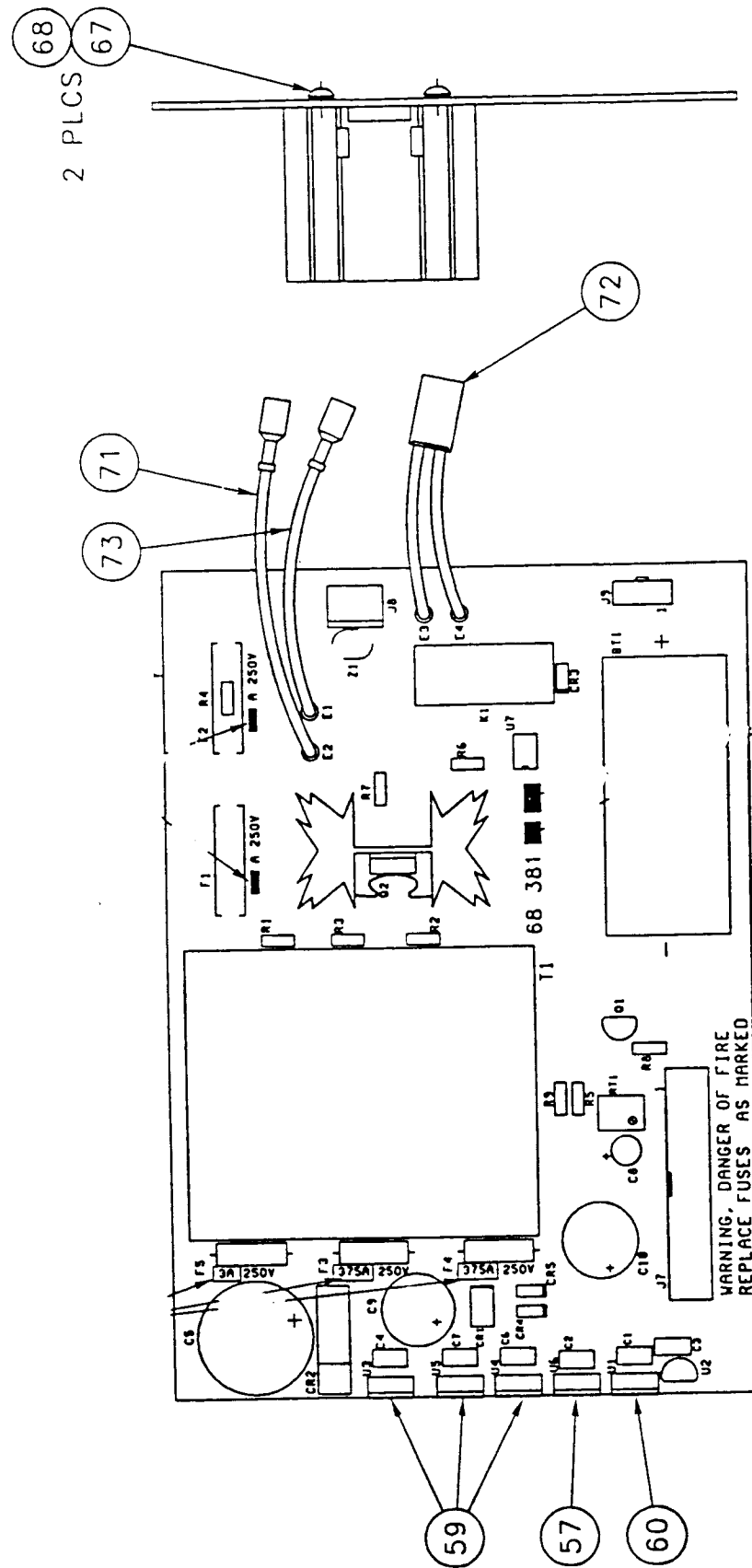

FIGURE 6.12 PARTS LOCATION DIAGRAM, POWER SUPPLY BOARD, GROUP 1

TABLE 6.12 POWER SUPPLY BOARD GROUP 1, PARTS LIST

(SHEET 1 OF 2)

ITEM NO.	REFERENCE DESIG.	DESCRIPTION	PART NUMBER
-	-	POWER SUPPLY BOARD, 120V	68 381 70
-	-	POWER SUPPLY BOARD, 240V	68 381 71
1		NOT USED	
2		NOT USED	
3		NOT USED	
4		NOT USED	
5		NOT USED	
6		NOT USED	
7		NOT USED	
8		NOT USED	
9		NOT USED	
10		NOT USED	
11	BT1	BATTERY, NI-CAD, RECHARGEABLE, 8.4V	17 807 76
12		NOT USED	
13	CR3,4,5	DIODE, IN914	17 AR 500
14	CR1	BRIDGE RECTIFIER, 1A, 50V	17 551 10
15	CR2	BRIDGE RECTIFIER, 6A, 50V	17 551 00
16		NOT USED	
17	C8	CAP., 10 μ F, 10%, 25V TANT	17 AW 236
18	C1 THRU 4, 6, 7	CAP., 1.0 μ F, 20%, 50V ML CER	17 BF 224
19	C5	CAP., 1500 μ F, 20% 25V, AL ELEC	17 405 87
20	C9,10	CAP., 2200 μ F, 20% 35V AL ELEC	17 405 88
21		NOT USED	
22	F1	FUSE, 1.6A 250V, SLO, 5MM X 20MM 120V BOARDS	17 BM 042
23	F1,2	FUSE, 0.8A 250V SLO, 5MM X 20MM 240V BOARDS	17 BM 039
24	F3,4	FUSE, 0.375A 250V SLO BLO, 2AG PIGTAIL	17 BM 151
25	F5	FUSE, 3A 250V SLO BLO, SAG PIGTAIL	17 BM 160
26		NOT USED	
27		NOT USED	
28	J7	CONN, PC HEADER, DBL ROW, 34 POSN	17 BR 625
29	J9	CONN, PC HDR, PLZD, LCH SGL 4PSN	17 BR 852
30	J8	CONN, RCPT, MALE PLZD, PCB 3 PSN	17 BR 901
31		NOT USED	
32		NOT USED	
33		FUSE CLIP, 5 MM X 20 MM PCB MOUNT	17 734 66
34		NOT USED	
35		NOT USED	
36	Q2	TRIAC, SNUBBERLESS, 8A 600V	17 550 91
37	T1	TRANSFORMER, 115/230V, 50/60 HZ	17 605 56
38	Q1	TRANS., N-CHAN, POWER FET, VN10KM	17 627 94
39	K1	RELAY, DPST, PC MOUNG 5VDC	17 653 06
40	R6	RES., 39.2 Ω , 1%, 1/8W FILM	17 AF 057
41	R5	RES., 232 Ω , 1%, 1/8W FILM	17 AF 131
42	R7, 9	RES., 750 Ω , 1%, 1/8W FILM	17 AF 180
43		NOT USED	

TABLE 6.12 POWER SUPPLY BOARD GROUP 1, PARTS LIST

(SHEET 2 OF 2)

ITEM NO.	REFERENCE DESIG.	DESCRIPTION	PART NUMBER
44	R8	RES., 10.0K, 1% 1/8W FILM	17 AF 288
45	RT1	RES., VARIABLE, 100K, 0.5W,PCB VERT ADJ	17 AN 138
46	R1, 2, 3	JUMPER, RESISTOR BODY 120V BOARDS	17 217 62
47	R3	JUMPER, RESISTOR BODY 240V BOARDS	17 217 62
48		NOT USED	
49	U6	VOLTAGE REGULATOR, -5V, 1A, 7905	17 AT 030
50	U2	VOLTAGE REGULATOR, 5V, 0.1A, 78L05	17 AT 041
51	U3, 4, 5	VOLTAGE REGULATOR, 5V, 1.5A, 7805AC	17 AT 060
52	U1	VOLTAGE REGULATOR, 12V 1.5A, 78 12AC	17 AT 061
53	U3	OPTO-ISOLATOR, 6 PIN DIP	17 633 90
54		NOT USED	
55		HEAT SINK, TO-220	17 062 82
56		NOT USED	
57		SCREW, SELF TAPPING #4 X 3/8 PN PH S BO	99 083 00
58		LOCK WASHER, SP #4 S4	99 121 36
59		NOT USED	
60	Z1	VARISTOR, 14MM, 250V	17 AN 693
61		CABLE ASSEMBLY, HEATER UNIT, RED	68 250 14
62		CABLE ASSEMBLY, AC MOTOR	68 250 17
63		CABLE ASSEMBLY, HEATER UNIT, WHITE	68 250 19

(This page is intentionally left blank.)

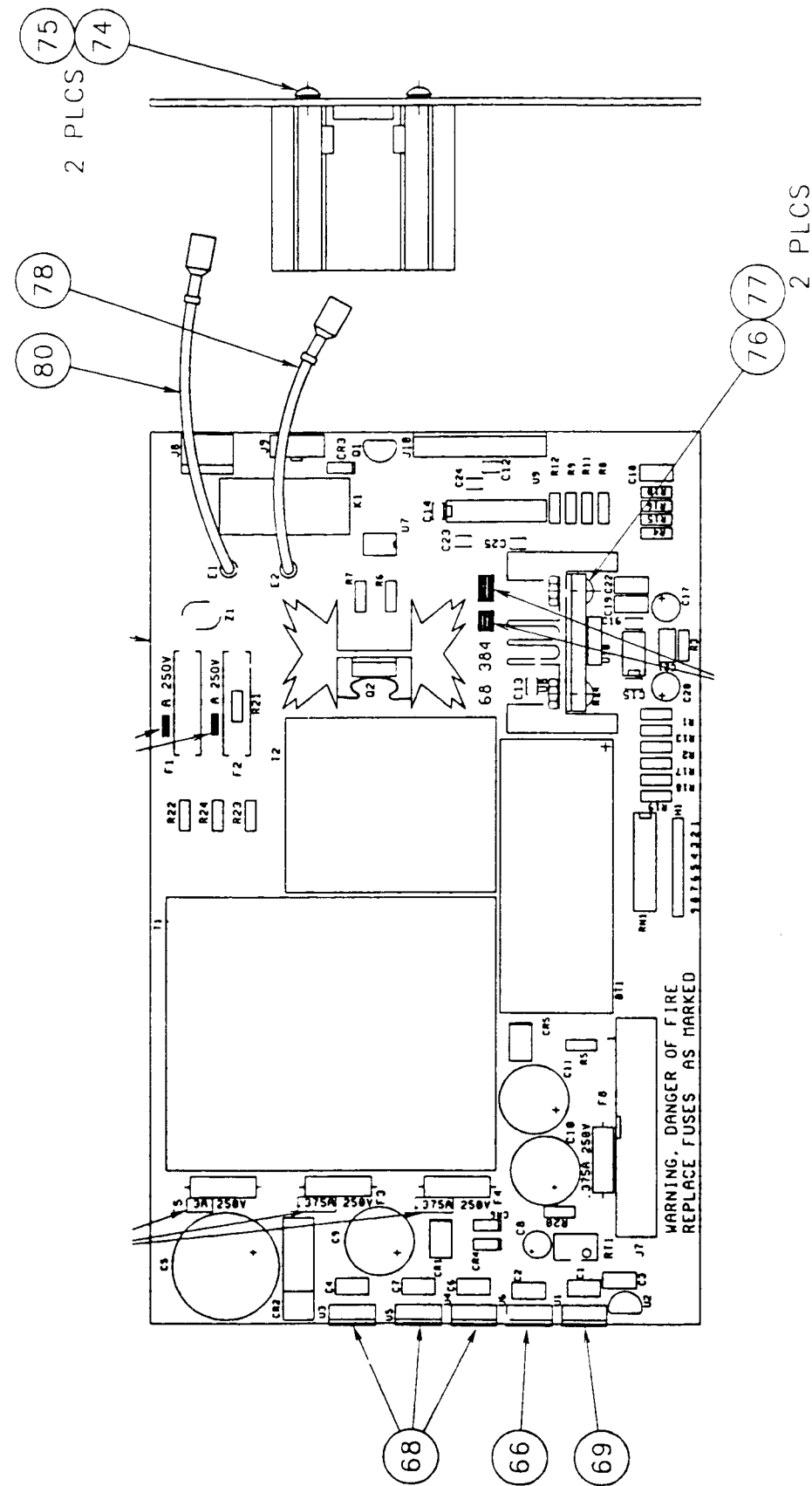

FIGURE 6.13 PARTS LOCATION DIAGRAM, POWER SUPPLY BOARD, GROUP 2

TABLE 6.13 POWER SUPPLY BOARD, GROUP 2, PARTS LIST

(SHEET 1 OF 2)

ITEM NO.	REFERENCE DESIG.	DESCRIPTION	PART NUMBER
-	-	POWER SUPPLY BOARD, 120V	68 384 70
-	-	POWER SUPPLY BOARD, 240V	68 384 71
1		NOT USED	
2		NOT USED	
3		NOT USED	
4		NOT USED	
5		NOT USED	
6		NOT USED	
7		NOT USED	
8		NOT USED	
9		NOT USED	
10		NOT USED	
11	BT1	BATTERY, NI-CAD, RECHARGEABLE, 8.4V	17 807 76
12		NOT USED	
13	CR3,4,5	DIODE, IN914	17 AR 500
14	CR1	BRIDGE RECTIFIER, 1A, 50V	17 551 10
15	CR2	BRIDGE RECTIFIER, 6A, 50V	17 551 00
16	C12 THRU 16	CAP., 0.1μF, 20%, 50V ML CER	17 BF 217
17		NOT USED	
18	C1 THRU 4, 6,7 18,19,21,22	CAP., 1.0 μF, 20%, 50V ML CER	17 BF 224
19	C5	CAP., 1500 μF, 20%, 25V, AL ELEC	17 405 87
20	C9,10,11	CAP., 2200 μF, 20%, 35V AL ELEC	17 405 88
21	C23,24,25	CAP., 100 pF 10% 25V	
22	C8,17,20	CAP., 10 μF, 10%, 25V TANT	17 AW 236
23	F1	FUSE, 1.6A 250V, SLO, 5MM X 20MM 120V BOARDS	17 BM 042
24	F1,2	FUSE, 0.8A 250V SLO, 5MM X 20MM 240V BOARDS	17 BM 039
25	F3,4,8	FUSE, 0.375A 250V SLO-BLO, 2AG PIGTAIL	17 BM 151
26	F5	FUSE, 3A 250V SLO-BLO, SAG PIGTAIL	17 BM 160
27	H1	CONN, PC HEADER, SGL ROW 9 POSN	17 BP 379
28	J7	CONN, PC HEADER, DBL ROW, 34 POSN	17 BR 625
29	J9	CONN, PC HDR, PLZD, LCH SGL 4PSN	17 BR 852
30	J8	CONN, RCPT, MALE PLZD, PCB 3 PSN	17 BR 901
31	J10	CONN, RCPT, MALE SGL LKG, PC 12 PN	
32		NOT USED	
33		FUSE CLIP, 5 MM X 20 MM PCB MOUNT	17 734 66
34		NOT USED	
35		NOT USED	
36		NOT USED	
37		NOT USED	
38		NOT USED	
39		NOT USED	
40		NOT USED	
41		NOT USED	
42		NOT USED	

TABLE 6.13 POWER SUPPLY BOARD, GROUP 2, PARTS LIST

(SHEET 2 OF 2)

ITEM NO.	REFERENCE DESIG.	DESCRIPTION	PART NUMBER
43	Q2	TRIAC, SNUBBERLESS, 8A 600V	17 550 91
44	T1	TRANSFORMER, 115/230V, 50/60 HZ	17 605 56
45	T2	TRANSFORMER, 115/230V, 50/60 HZ	17 605 57
46	Q1	TRANS., N-CHAN, POWER FET, VN10KM	17 627 94
47	K1	RELAY, DPST, PC MOUNG 5VDC	17 653 06
48	R1,2,17,18	RES., 84.5 K, 1%, 1/8W FILM	17 AF 377
49	R6	RES., 39.2 Ω , 1%, 1/8W FILM	17 AF 057
50	R5, 9	RES., 232 Ω , 1%, 1/8W FILM	17 AF 131
51	R7, 8	RES., 750 Ω , 1%, 1/8W FILM	17 AF 180
52	R11	RES., 130 Ω , 1%, 1/8W FILM	17 AF 107
53	R12	RES., 432 Ω , 1%, 1/8W FILM	17 AF 157
54	R19	RES., 1.50 K, 1%, 1/8W FILM	17 AF 209
55	R15,16	RES., 4.32 K, 0.1% MTL FILM 1/8W	17 AN 312
56	R3,4	RES., 33.2 K, 0.1% MTL FILM 1/8W	17 AN 350
57	R20	RES., 20.0 K, 1%, 1/8W FILM	17 AF 317
58	RN1	RES., NTWK, 8 @ 10 K 2% 0.25W/R DIP	17 AU 530
59	RT1	RES., VARIABLE, 20K, 0.5W,PCB VERT ADJ	17 AN 132
60	Z1	VARISTOR, 14MM, 250V	17 AN 693
61	U8	IC, MOTOR CONT, 3 PHASE BRUSHLESS	17 633 62
62	U10	IC, OP AMP 358A	17 631 85
63	U9	IC, DIFFERENTIAL LINE RECEIVER	17 634 02
64	R21 THRU 23	JUMPER, RESISTOR BODY 120V BOARDS	17 217 62
65	R24	JUMPER, RESISTOR BODY 240V BOARDS	17 217 62
66	U6	VOLTAGE REGULATOR, -5V, 1A, 7905	17 AT 030
67	U2	VOLTAGE REGULATOR, 5V, 0.1A, 78L05	17 AT 041
68	U3, 4, 5	VOLTAGE REGULATOR, 5V, 1.5A, 7805AC	17 AT 060
69	U1	VOLTAGE REGULATOR, 12V 1.5A, 78 12AC	17 AT 061
70	U7	OPTO-ISOLATOR, 6 PIN DIP	17 633 90
71	Q2	HEAT SINK, TO-220	17 062 82
72	U8	HEAT SINK, TO-220	17 062 98
73		NOT USED	
74		SCREW, SELF-TAPPING #4 X 3/8 PN PH S BO	99 083 00
75		LOCK WASHER, SP #4 S4	99 121 36
76		NOT USED	
77		NOT USED	
78		CABLE ASSEMBLY, HEATER UNIT, RED	68 250 14
79		NOT USED	
80		CABLE ASSEMBLY, HEATER UNIT, WHITE	68 250 19
81	R14	RES., 0.5 Ω , 1%, 1W	17 AN 035
82	R10	RES., 825 Ω , 1%, 1/8W FILM	17 AF 184
83	R13	RES., 324 Ω , 1%, 1/8W FILM	17 AF 145

(This page is intentionally left blank.)

TABLE 6.14 CABINET STAND ASSEMBLY, PARTS LIST

PART NO. 68 400 70CC

(SHEET 1 OF 1)

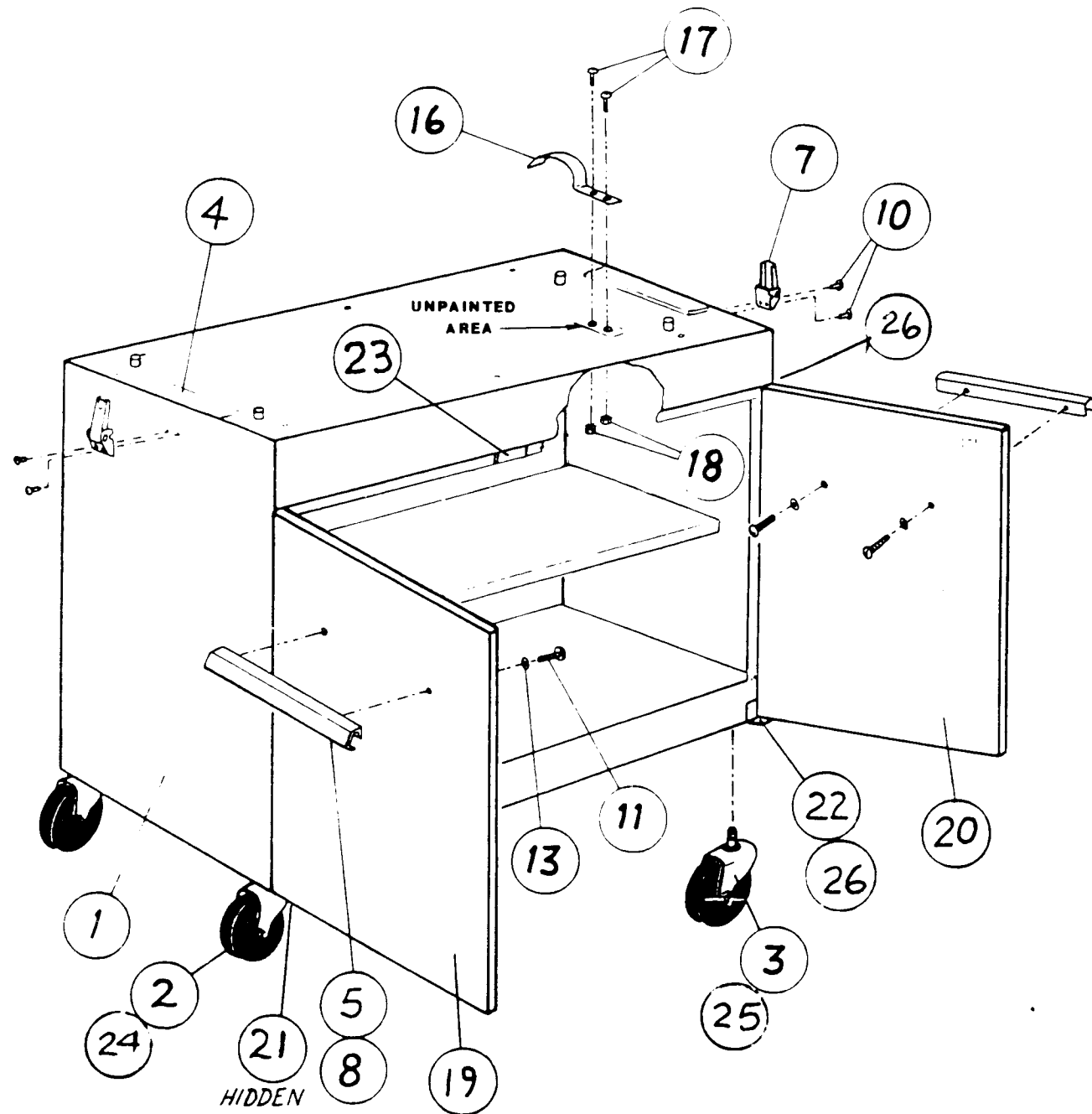

FIGURE 6.14 PARTS LOCATION DIAGRAM, CABINET STAND ASSEMBLY

ITEM NO.	REFERENCE DESIGNATION	DESCRIPTION	PART NUMBER
1		CABINET STAND ASSY	68 400 70CC
2		CASTER WITHOUT BRAKE, 4"	68 901 72
3		CASTER WITH BRAKE, 4"	68 901 71
4		SPONGE STRIP, NEO.	26 800 33
5		HANDLE	68 400 08
6		NOT USED	
7		LATCH, CABINET	24 717 00
8		TAPE MET. POLYEST, BLUE	26 801 23
9		NOT USED	
10		SCR, 6 X 1/4 B. RD. SL SS	99 084 47
11		SCR, 8-32 X 1 TR PH SS	99 033 47
12		NOT USED	
13		WASH. NO. 8, LK SP S CAD	99 122 90
14		NOT USED	
15		NOT USED	
16		SPRING, GROUNDING	68 400 27
17		SCR, 6 - 32 X 5/16 TR PH SS	99 022 98
18		NUT, 6 - 32 HX "KEPS" S CAD	99 105 34
19		DOOR, L.H.	68 400 21
20		DOOR, R.H.	68 400 20
21		HINGE, DOOR, L.H.	68 400 23
22		HINGE, DOOR, R.H.	68 400 22
23		MAGNETIC CATCH	68 901 13
24		CASTER WITHOUT BRAKE, 5"	68 400 56
25		CASTER WITH BRAKE, 5"	68 400 55
26		HINGE BEARING	63 571 10

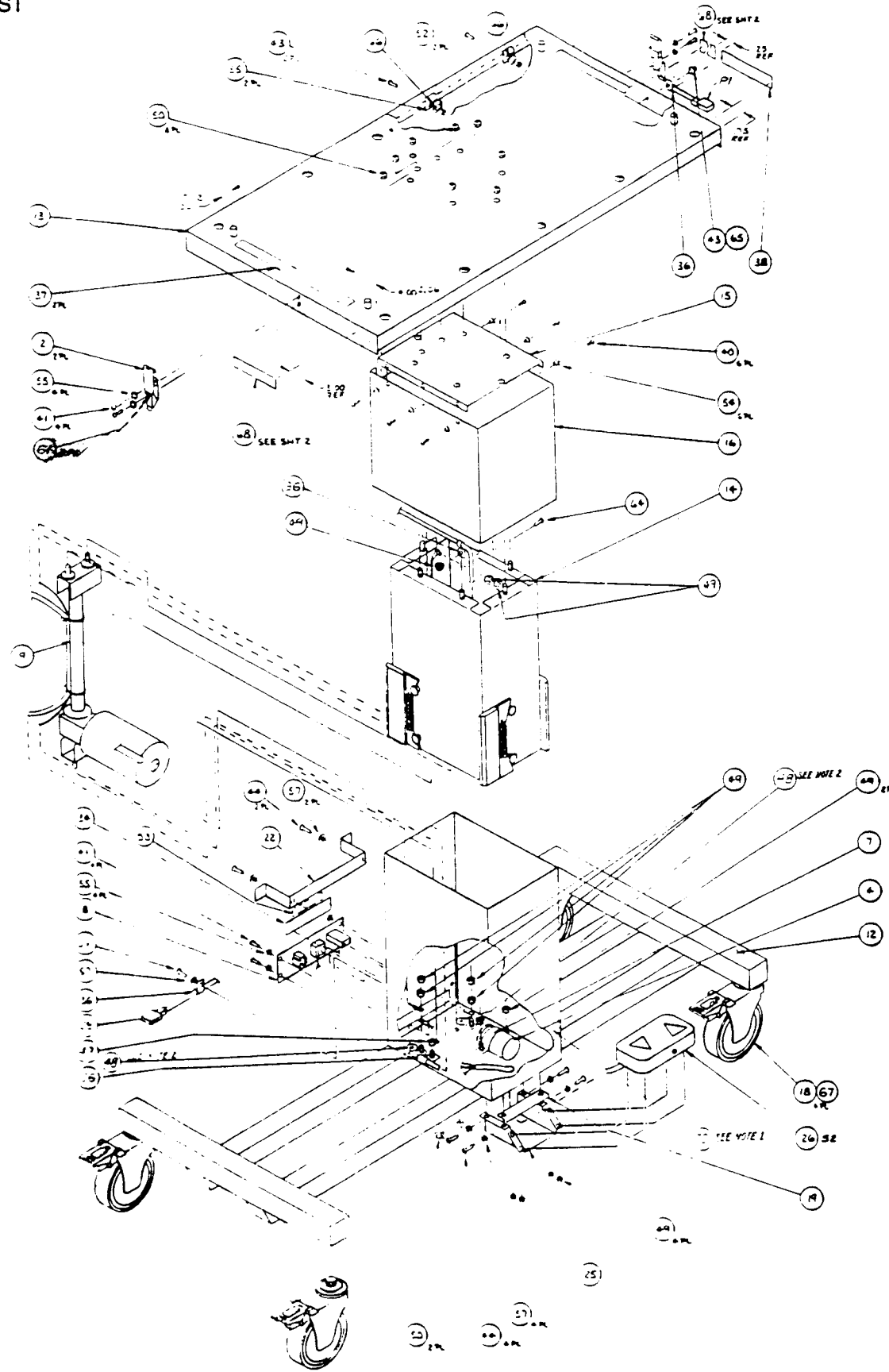

FIGURE 6.15 PARTS LOCATION DIAGRAM, VHA STAND ASSEMBLY (SHEET 1 OF 2)

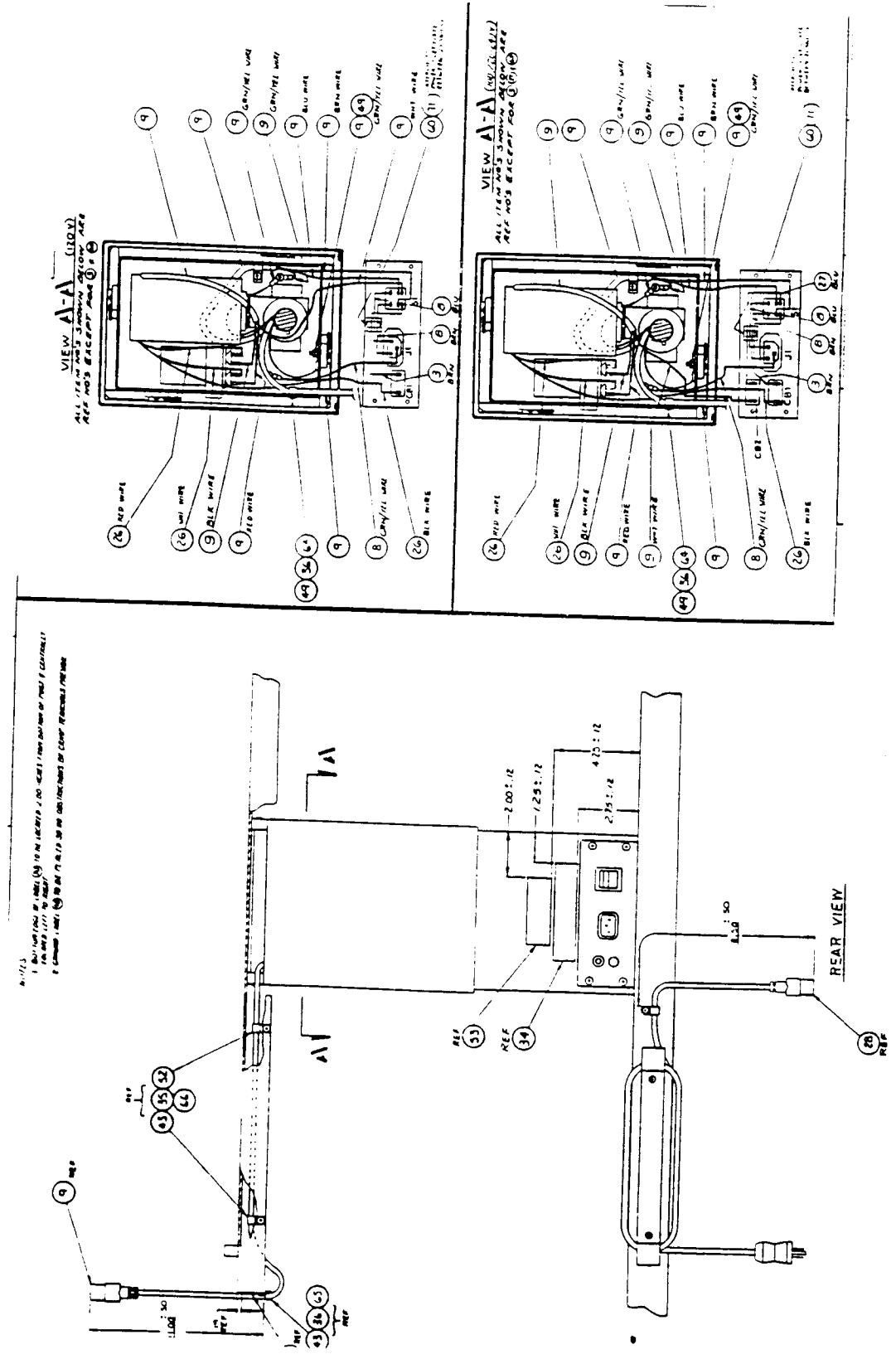

FIGURE 6.15 PARTS LOCATION DIAGRAM, VHA STAND ASSEMBLY (SHEET 2 OF 2)

TABLE 6.15 VHA STAND ASSEMBLY, PARTS LIST

(SHEET 1 OF 3)

ITEM NO.	REFERENCE DESIG.	DESCRIPTION	PART NUMBER
		VHA STAND ASSEMBLY, 120V, ENG	68 415 70
		VHA STAND ASSEMBLY, 120V, SPN	68 415 71
		VHA STAND ASSEMBLY, 120V, FRN	68 415 72
		VHA STAND ASSEMBLY, 220/240V, ENG	68 415 80
		VHA STAND ASSEMBLY, 220/240V, SPN	68 415 81
		VHA STAND ASSEMBLY, 220/240V, FRN	68 415 82
		VHA STAND ASSEMBLY, 220V, GER	68 415 83
		VHA STAND ASSEMBLY, 220/240V, ITL	68 415 84
1		NOT USED	
2		DRAW LATCH, MODIFIED	68 404 20
3		JUMPER BRKR SW	68 405 39
4		CAP, 30 MFD, 240V 60HZ, MET PLYPR	17 405 81
		CAP, 10 MFD, 370V 60HZ, MET PLYPR	17 405 82
		CAP, 50 MFD, 240V 60HZ, MET PLYPR	17 405 83
5		NOT USED	
6		NOT USED	
7		CAPACITOR CLAMP 100V/120V UNITS	68 404 24
		CAPACITOR CLAMP, 220/240V UNITS	68 404 25
8		POWER INLET PLATE ASSY, 120V ENG	68 415 50
		POWER INLET PLATE ASSY, 120V SPN	68 415 51
		POWER INLET PLATE ASSY, 120V FRN	68 415 52
		POWER INLET PLATE ASSY, 220/240V ENG	68 415 53
		POWER INLET PLATE ASSY, 220/240V SPN	68 415 54
		POWER INLET PLATE ASSY, 220/240V FRN	68 415 55
		POWER INLET PLATE ASSY, 220V GER	68 414 56
		POWER INLET PLATE ASSY, 220/240V ITL	68 414 58
9		ACTUATOR ASSY 120V 50/60HZ	68 405 32
		ACTUATOR ASSY 220/240V 50/60HZ	68 405 33
		ACTUATOR ASSY 100V 50/60HZ	68 405 32
10		BASE COVER	68 415 01
11		FOAM TAPE, DBL SIDED, 3MY-4952	AR
12		BASE WELDMENT	68 415 00
13		PLATFORM	68 415 05
14		COLUMN, INNER ASSY (REFER TO TABLE 6.12)	68 404 40
15		PLATE, TOP	68 405 13
16		ESCUTCHEON	68 415 20
17		NOT USED	
18		CASTER, 5.00 FULL LOCK	68 416 16
19		COVER PLATE, FOOT SWITCH	68 415 07
20		NOT USED	
21		NOT USED	
22		CLEAT, POWER CORD	68 415 22
23		NOT USED	
24		NOT USED	

TABLE 6.15 VHA STAND ASSEMBLY, PARTS LIST

(SHEET 2 OF 3)

ITEM NO.	REFERENCE DESIG.	DESCRIPTION	PART NUMBER
25		FOOT SWITCH ASSEMBLY	68 415 46
26		FOOT SWITCH ASSEMBLY INTL	68 405 47
27		JUMPER, BRKR-SW	68 405 30
28		CABLE ASSY, AC POWER 120V	17 AZ 100
		CABLE ASSY, AC POWER 220/240V	17 AZ 200
29		NOT USED	
30		NOT USED	
31		NOT USED	
32		NOT USED	
33		NOT USED	
34		NOT USED	
35		CLAMP, CORD	17 061 25
36		CLAMP, CORD	17 732 42
37		SPONGE STRIP, NEO	26 800 33
38		LABEL, POWER CORD ENG	68 415 30
		LABEL, POWER CORD SPN	68 415 31
		LABEL, POWER CORD FRN	68 415 32
		LABEL, POWER CORD GER	68 415 33
		LABEL, POWER CORD ITL	68 415 34
39		NOT USED	
40		SCREW, 4 - 40 x 1/4 TR PH SS	99 010 56
41		SCREW, 6 - 32 x 3/8 TR PH SS	99 023 31
42		NOT USED	
43		SCREW, 8 - 32 x 3/8 TR PH SS	99 031 38
44		SCREW, 10 - 32 x 3/8 TR PH SS	99 041 27
45		NOT USED	
46		NOT USED	
47		NOT USED	
48		GROUND LABEL	68 212 00
49		NUT, 6 - 32 HX "KEPS" S CA	99 105 34
50		NUT, 1/4-20 HX "KEPS" S CA	99 109 41
51		NOT USED	
52		NUT, 8-32 HX "KEP" S CA	99 106 32
53		CAUTION LABEL, ELECTRIC SHOCK, ENG	68 422 90
		CAUTION LABEL, ELECTRIC SHOCK, SPN	68 422 91
		CAUTION LABEL, ELECTRIC SHOCK, FRN	68 422 92
		CAUTION LABEL, ELECTRIC SHOCK, GER	68 422 93
		CAUTION LABEL, ELECTRIC SHOCK, ITL	68 422 94
54		WASHER, #4 LK SP SS	99 121 36
55		WASHER, #6 LK SP SS	99 122 16
56		NOT USED	
57		WASHER, #10 LK SP S CA	99 124 16
58		NOT USED	
59		NOT USED	

TABLE 6.15 VHA STAND ASSEMBLY, PARTS LIST

(SHEET 3 OF 3)

ITEM NO.	REFERENCE DESIG.	DESCRIPTION	PART NUMBER
60		CABLE TIE MOUNT	17 061 87
61		CATCH, SECONDARY	68 404 21
62		NOT USED	
63		NOT USED	
64		SCREW, 6 - 32 x 1/2 TR PH SS	99 023 92
65		WASHER, LK EXT #8 SS	99 122 93
66		WASHER, FL #8 SS	99 122 62
67		LOCTITE 222	AR
68		HEAVY EQUIPMENT LABEL, ENG	68 415 40
		HEAVY EQUIPMENT LABEL, SPN	68 415 41
		HEAVY EQUIPMENT LABEL, FRN	68 415 42
		HEAVY EQUIPMENT LABEL, GER	68 415 43
		HEAVY EQUIPMENT LABEL, ITL	68 415 44
69		SCREW, 10 - 32 X 1/2" FL PH SS	99 042 06
70		INTERMITTENT OPERATION LABEL, ENG	68 415 60
		INTERMITTENT OPERATION LABEL, SPN	68 415 61
		INTERMITTENT OPERATION LABEL, FRN	68 415 62
		INTERMITTENT OPERATION LABEL, GER	68 415 63
		INTERMITTENT OPERATION LABEL, ITL	68 415 64

(This page is intentionally left blank.)

TABLE 6.16 INNER COLUMN ASSEMBLY, PARTS LIST

(SHEET 1 OF 1)

ITEM NO.	REFERENCE DESIG.	DESCRIPTION	PART NUMBER
-		INNER COLUMN ASSEMBLY	68 404 40
1		COLUMN, INNER	68 405 11
2		GIB, SELF-ADJUSTING	68 405 25
3		WEDGE, GIB	68 405 27
4		SPRING, EXTENSION	68 405 29
5		BUSHING, RETAINER	68 405 31
6		LABEL, GROUND	68 212 00
7		NUT, 10 - 32 HX SS	99 107 00
8		NOT USED	
9		SCREW, 10 - 32 x 5/8 FL SK S BO	99 042 63
10		SCREW, 10 - 32 x 3/16 SH SL SS	99 195 02
11		LUBRICANT, DOW CORNING #111	AR
12		LOCTITE, 271	AR

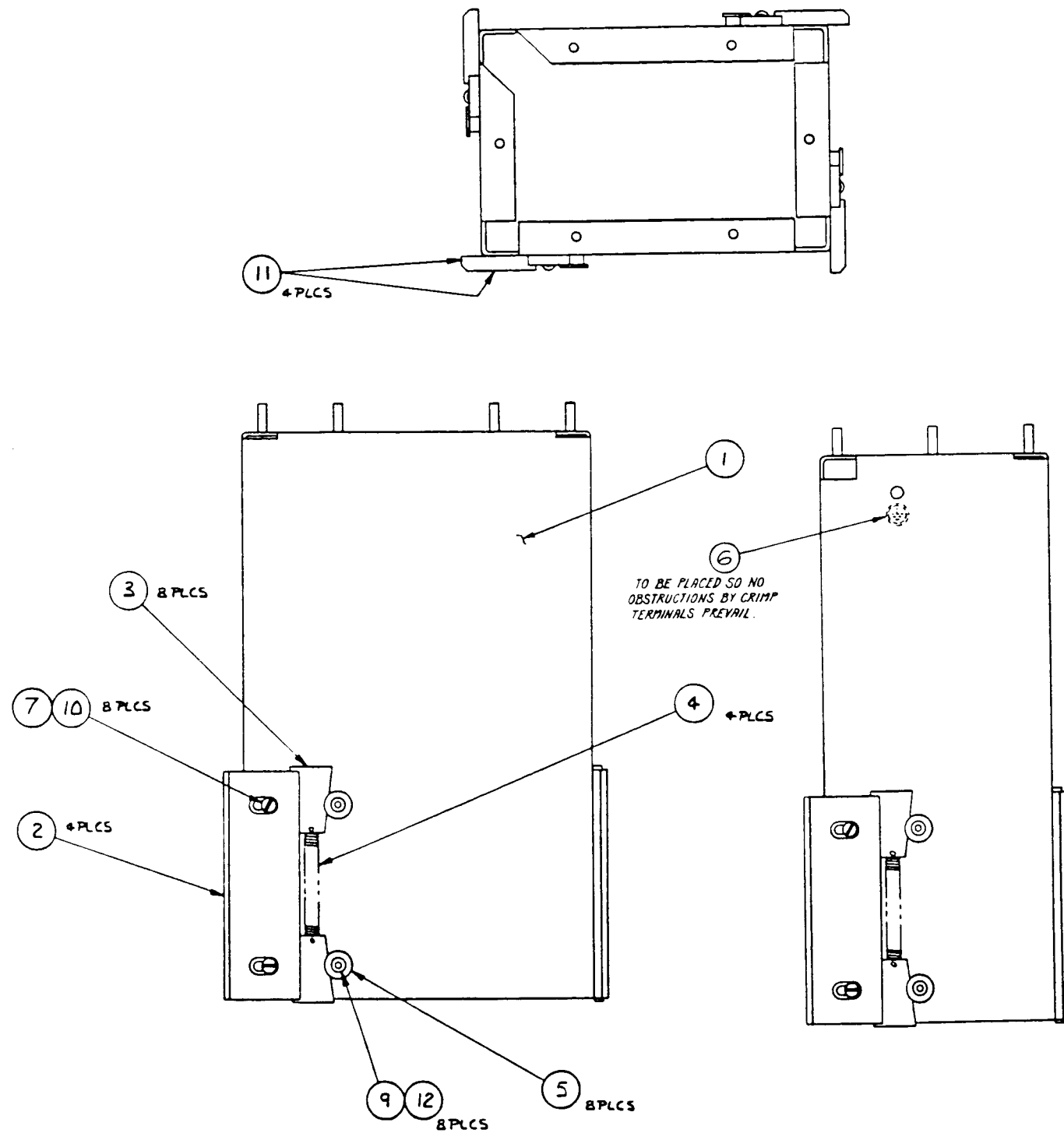

FIGURE 6.16 PARTS LOCATION DIAGRAM, INNER COLUMN ASSEMBLY

TABLE 6.17 CABINET, VHA STAND, PARTS LIST

(SHEET 1 OF 1)

ITEM NO.	REFERENCE DESIG.	DESCRIPTION	PART NUMBER
1		VHA STAND CABINET ASSEMBLY	68 416 80
2		VHA STAND CABINET	68 416 60
3		DOOR ASSEMBLY	68 416 85
4		SCREW, 10 - 32 X 5/8-INCH, PHILLIPS HEAD (QTY 4)	99 042 58
5		LOCK WASHER, NO. 10 (QTY 4)	99 123 94
6		LOCK WASHER, NO. 6 (QTY 2)	99 122 20
7		SCREW, 6 - 32 X 3/8-INCH, PHILLIPS HEAD (QTY 2)	99 023 31
8		PIVOT PIN	68 416 67
9		HEX NUT, 8 - 32, KEPS	99 106 32
10		HINGE PLATE	68 416 66
		MAGNETIC CATCH ASSY, VHA DOOR	68 416 55

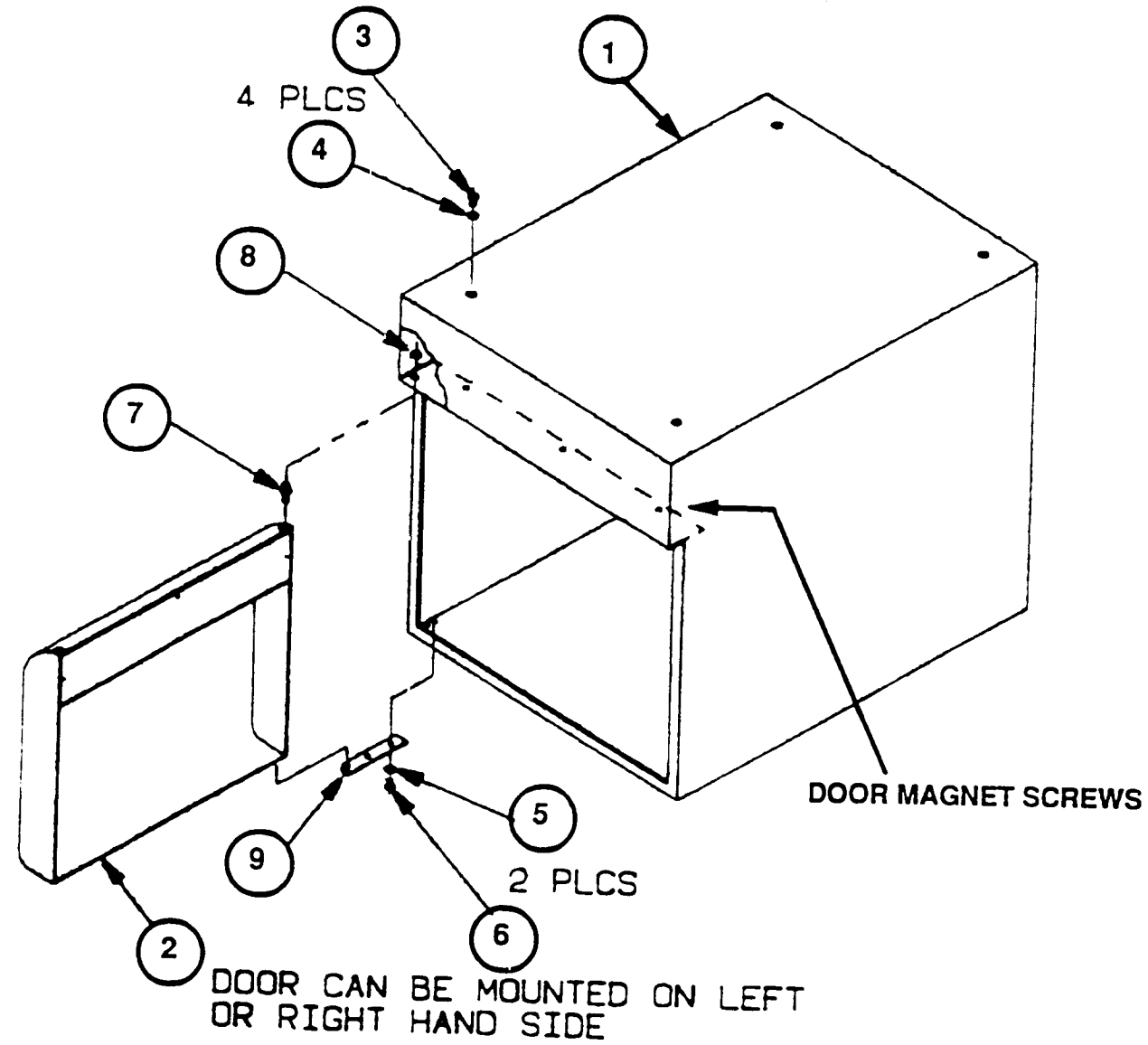

FIGURE 6.17 PARTS LOCATION DIAGRAM, CABINET, VHA STAND

SECTION 7 DIAGRAMS

7.1 GENERAL

This section provides schematics and wiring diagrams for the Air-Shields Isolette® Infant Incubators, C400 and 450 QT®.

(This page is intentionally left blank.)

4

3

2

1

ITEM NO.	DWG NO.	IDENT NO.	DESCRIPTION	QTY	U/M

REVISIONS	
2	ECN 10984 REVISED & REDRAWN
1	VEY 11 APR 94

D

D

C

C

B

B

A

A

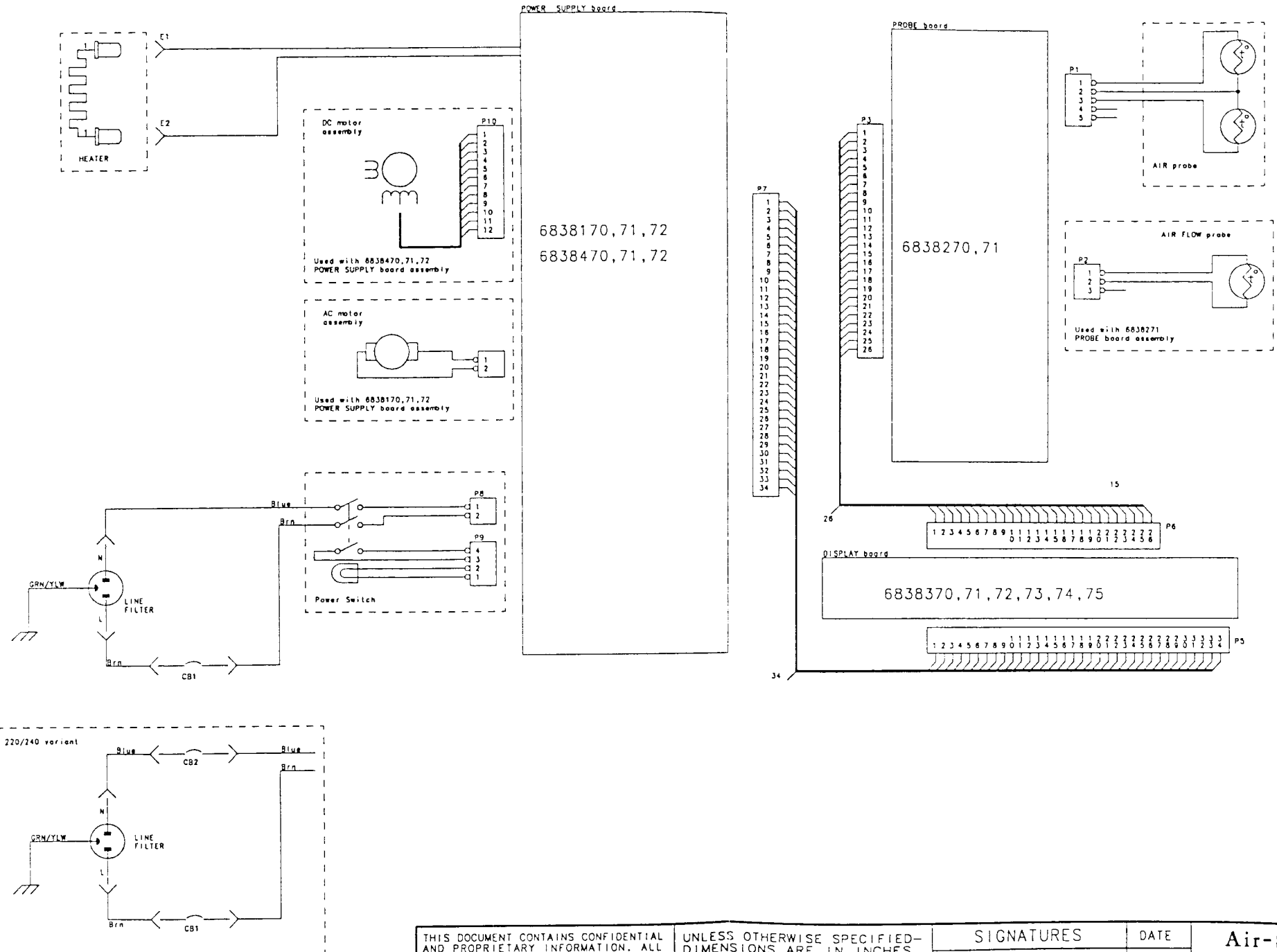

THIS DOCUMENT CONTAINS CONFIDENTIAL AND PROPRIETARY INFORMATION. ALL INFORMATION DISCLOSED HEREIN IS AND REMAINS THE PROPERTY OF AIR-SHIELDS INC. AND MAY NOT BE DISCLOSED TO ANY THIRD PARTY WITHOUT THE EXPRESSED WRITTEN CONSENT OF AIR-SHIELDS INC.

FIRST USED ON:
 682527-, 8-
 682537-, 8-
 682547-, 8-

UNLESS OTHERWISE SPECIFIED- DIMENSIONS ARE IN INCHES. TOLERANCES ON:
 FRACTIONS DECIMALS ANGLES
 ± ---- .XX ± ---- ± ----
 .XXX ± ----
 ALL SURFACE FINISH ---- ✓ MAX.
 DO NOT SCALE DRAWING

MATERIAL

SIGNATURES
 DRAWN V. YARNELL
 CHKD
 ENG
 APVD

DATE
 11 APR 94
 FINISH

Air-Shields
 330 Jacksonville Road, Hatboro Pa. 19040

INTERCONNECT DIAGRAM,
 C400/C450

SIZE C 68 251 10

SCALE NONE SHEET 1 OF 1

68 251 10

NOTES:

1. INSTALL FUSES AND JUMPER RESISTORS PER:

A) 68 381 70 GETS F1,R1,R2,R4.

B) 68 381 71 GETS F1,F2,R3.

ITEM NO.	DWG SIZE	IDENT NO.	DESCRIPTION	QTY	U/M
----------	----------	-----------	-------------	-----	-----

REVISIONS	
1. ISSUE:DRN 882-1	
VEY 13 OCT 93	VK 25 OCT 93
2. ECN 10858 REV. & REDRWN	
DRU 14 MAR 94	

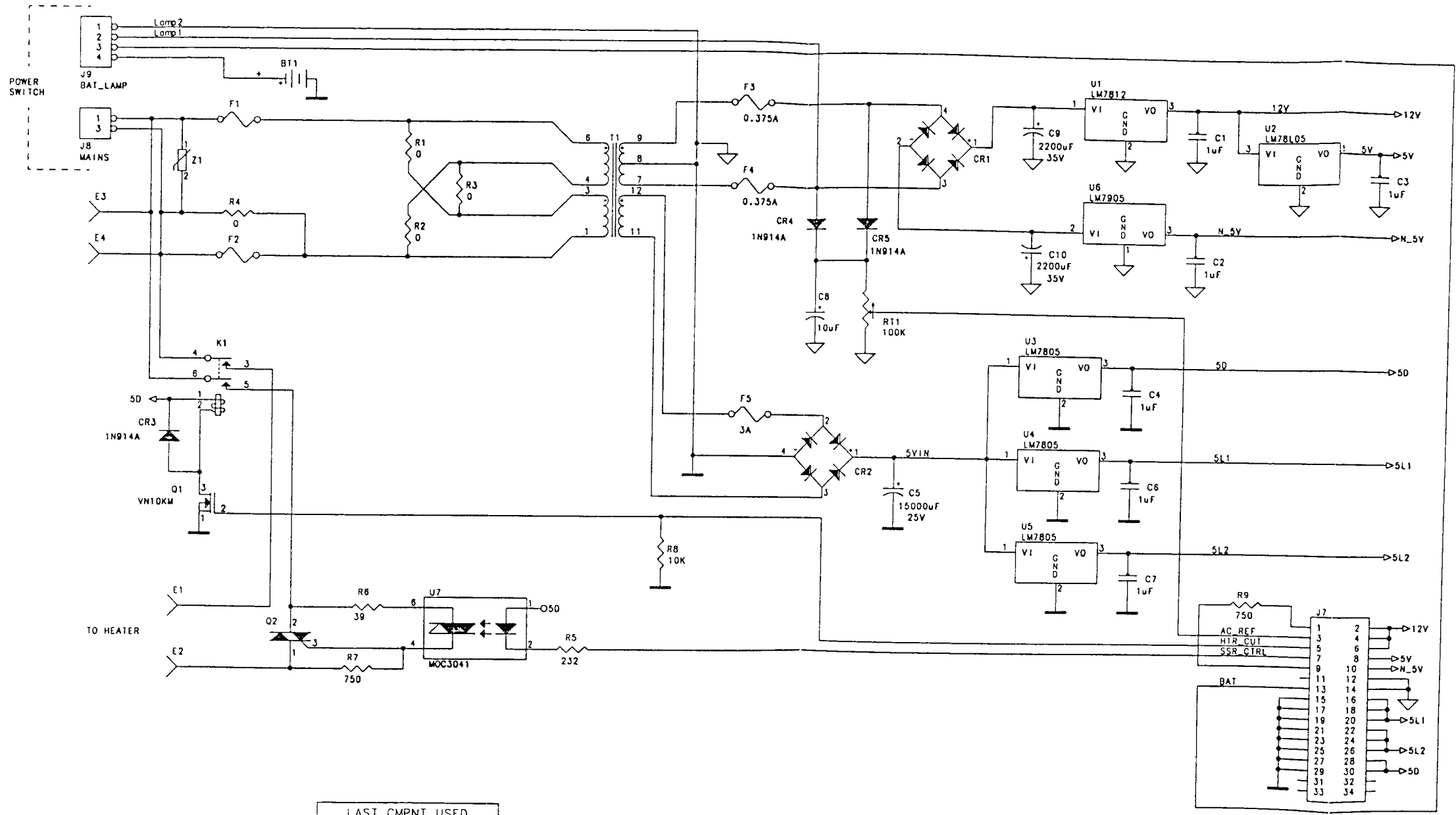

LAST CMPNT USED	
USED	OMITTED
BT1	
C11	
CR5	
E4	
F6	
J11	
K1	
Q2	
R9	
RT1	
T2	
TP1	
U7	

THIS DOCUMENT CONTAINS CONFIDENTIAL AND PROPRIETARY INFORMATION. ALL INFORMATION DISCLOSED HEREIN IS AND REMAINS THE PROPERTY OF AIR-SHIELDS INC. AND MAY NOT BE DISCLOSED TO ANY THIRD PARTY WITHOUT THE EXPRESSED WRITTEN CONSENT OF AIR-SHIELDS INC.

FIRST USED ON:
68 381 70,71

UNLESS OTHERWISE SPECIFIED- DIMENSIONS ARE IN INCHES. TOLERANCES ON:
FRACTIONS DECIMALS ANGLES
± -- .XX ± -- ± --
ALL SURFACE FINISH --- ✓ MAX.
DO NOT SCALE DRAWING

MATERIAL
FINISH

SIGNATURES		DATE
DRAWN	V. YARNELL	07 OCT 93
CHKD		
ENG	V. KRAVETS	25 OCT 93
APVD		

Air-Shields
330 Jacksonville Road, Hatboro Pa. 19040

SCHMATIC,
POWER SUPPLY BD.
(NON-IEC)C450

SIZE	68 381 15
SCALE	NONE
SHEET	1 OF 1

68 381 15

NOTES:

1. INSTALL FUSES AND 0 Ohms JUMPERS PER:

68 384 70
68 384 71

F1
F1, F2

R21, R22, R23
R24

REVISIONS	
1. ISSUE: DRN 882-10	
DRU 14 APR 94	RK 23 JUN 94
2. ECN 11117: (B2) R10 WAS 750; R13 WAS 750; R14 WAS 1.0	
DRU 09 AUG 94	AS 08 AUG 94

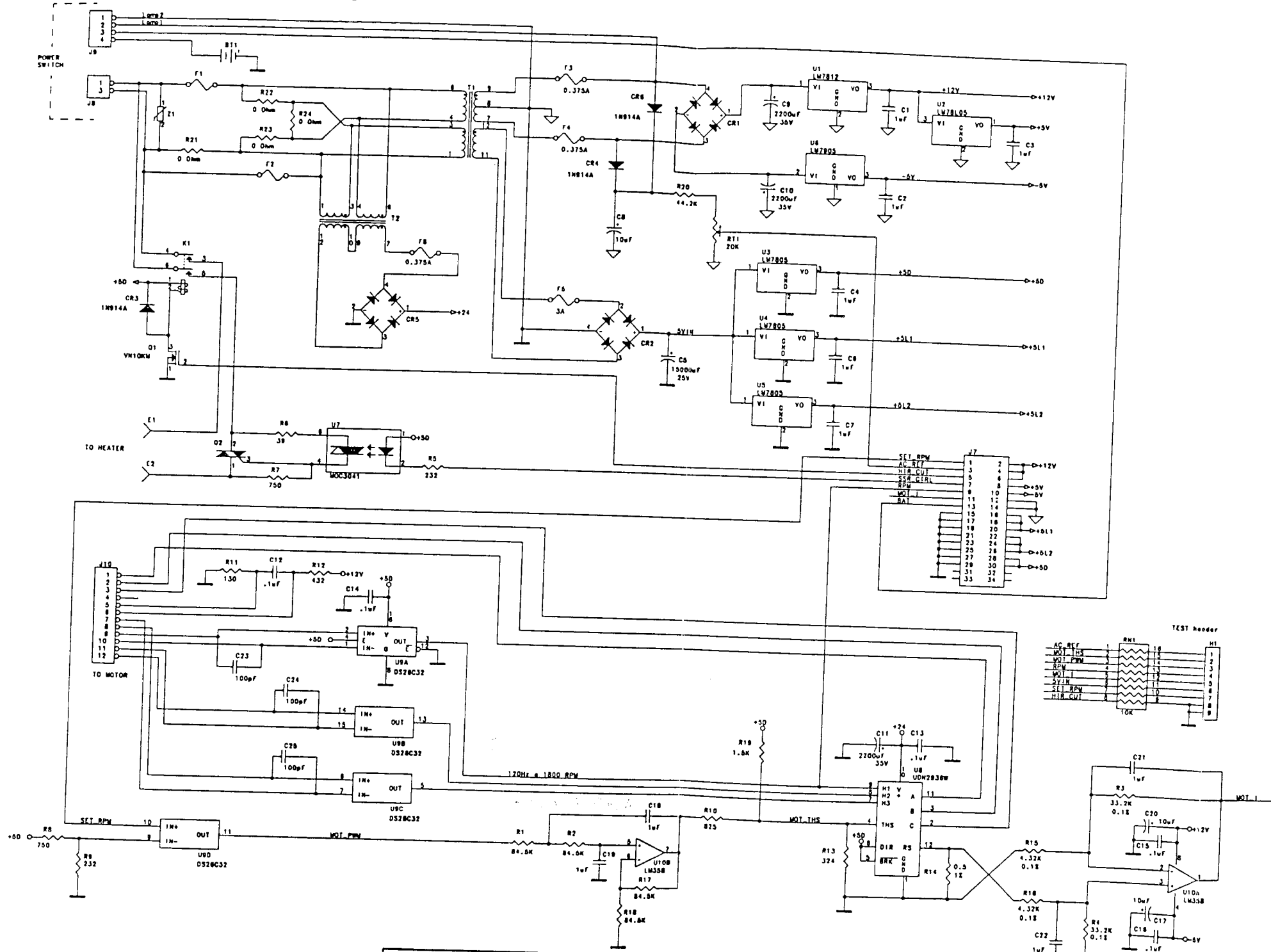

THIS DOCUMENT CONTAINS CONFIDENTIAL AND PROPRIETARY INFORMATION. ALL INFORMATION DISCLOSED HEREIN IS AND REMAINS THE PROPERTY OF AIR-SHIELDS INC. AND MAY NOT BE DISCLOSED TO ANY THIRD PARTY WITHOUT THE EXPRESSED WRITTEN CONSENT OF AIR-SHIELDS INC.

UNLESS OTHERWISE SPECIFIED- DIMENSIONS ARE IN INCHES. TOLERANCES ON: FRACTIONS DECIMALS ± --- .XX ± --- ± --- .XXX ± --- ✓ MAX.

FIRST USED ON:
68 384 70, 71

DO NOT SCALE DRAWING
MATERIAL

SIGNATURES		DATE
DRWN	D.URBAN	14 APR 94
CHKD		
ENG	R.KOLAROVIC	23 JUN 94
APVD		

Air-Shields
330 Jacksonville Road, Hatboro Pa. 19040

SCHEMATIC, POWER BD.,
C400/450 IEC

SIZE	C	68 384 15
SCALE	NONE	SHEET 1 OF 1

68 384 15

REVISIONS

1	ISSUE ORN 882-1
2	KEY
3	25 OCT 93
4	REV. W. REDMAN
5	08 APR 94
6	14 APR 94
7	31 OCT 94
8	08 APR 94
9	08 APR 94
10	08 APR 94
11	08 APR 94
12	08 APR 94
13	08 APR 94
14	08 APR 94
15	08 APR 94
16	08 APR 94
17	08 APR 94
18	08 APR 94
19	08 APR 94
20	08 APR 94
21	08 APR 94
22	08 APR 94
23	08 APR 94
24	08 APR 94
25	08 APR 94
26	08 APR 94
27	08 APR 94
28	08 APR 94
29	08 APR 94
30	08 APR 94
31	08 APR 94
32	08 APR 94
33	08 APR 94
34	08 APR 94
35	08 APR 94
36	08 APR 94
37	08 APR 94
38	08 APR 94
39	08 APR 94
40	08 APR 94
41	08 APR 94
42	08 APR 94
43	08 APR 94
44	08 APR 94
45	08 APR 94
46	08 APR 94
47	08 APR 94
48	08 APR 94
49	08 APR 94
50	08 APR 94
51	08 APR 94
52	08 APR 94
53	08 APR 94
54	08 APR 94
55	08 APR 94
56	08 APR 94
57	08 APR 94
58	08 APR 94
59	08 APR 94
60	08 APR 94
61	08 APR 94
62	08 APR 94
63	08 APR 94
64	08 APR 94
65	08 APR 94
66	08 APR 94
67	08 APR 94
68	08 APR 94
69	08 APR 94
70	08 APR 94
71	08 APR 94
72	08 APR 94
73	08 APR 94
74	08 APR 94
75	08 APR 94
76	08 APR 94
77	08 APR 94
78	08 APR 94
79	08 APR 94
80	08 APR 94
81	08 APR 94
82	08 APR 94
83	08 APR 94
84	08 APR 94
85	08 APR 94
86	08 APR 94
87	08 APR 94
88	08 APR 94
89	08 APR 94
90	08 APR 94
91	08 APR 94
92	08 APR 94
93	08 APR 94
94	08 APR 94
95	08 APR 94
96	08 APR 94
97	08 APR 94
98	08 APR 94
99	08 APR 94
100	08 APR 94

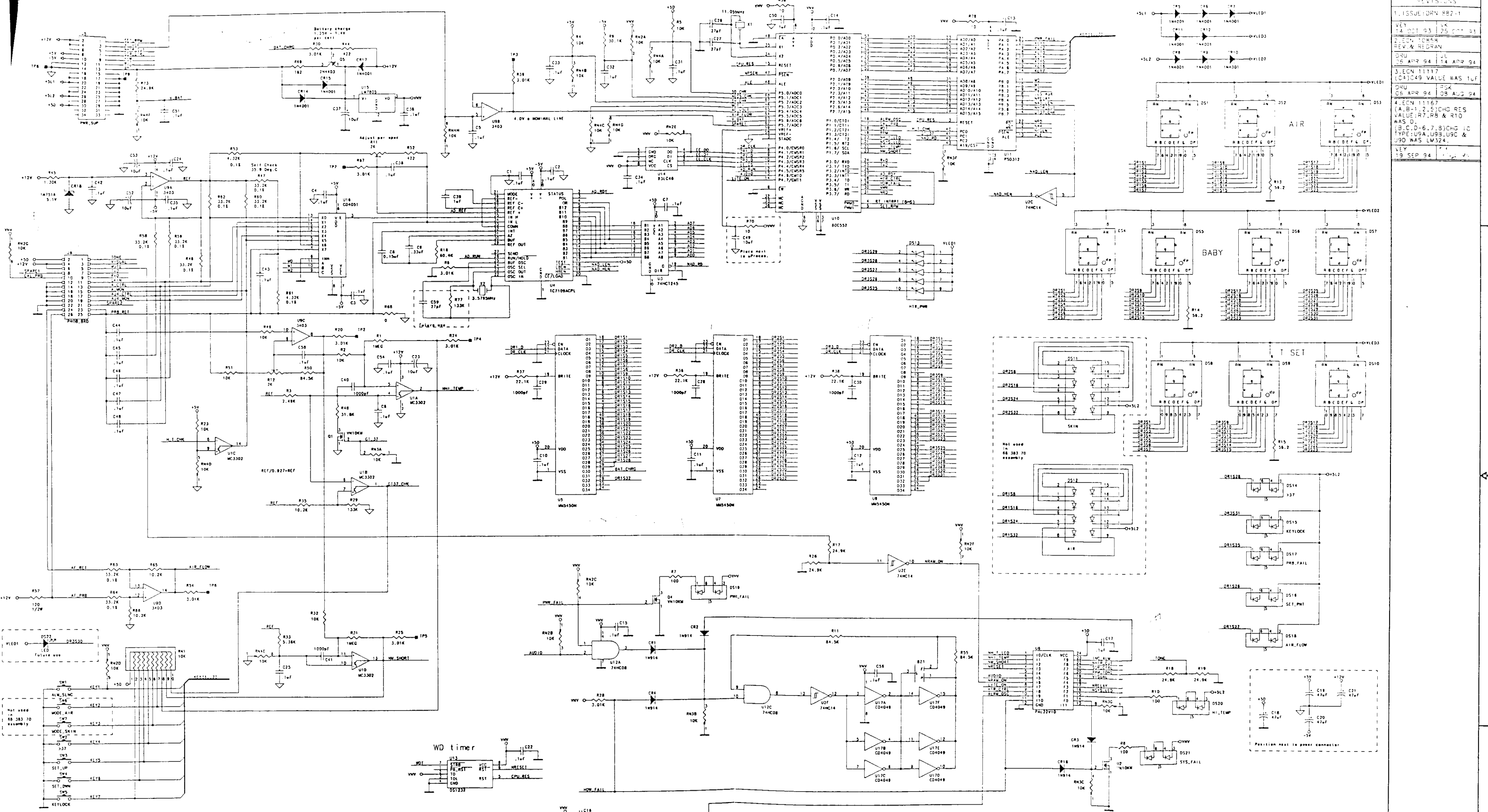

COMPONENT USED

USED	OMITTED
B21	
C59	
CR18	
DS22	
J6	
C5	
R78	
R94	
R12	
SW7	
TP9	
U17	

SPARES

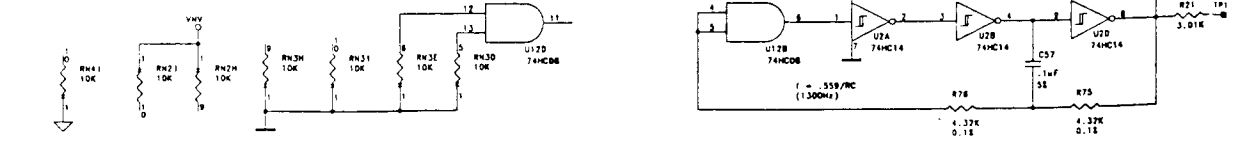

THIS DOCUMENT CONTAINS CONFIDENTIAL AND PROPRIETARY INFORMATION. ALL INFORMATION DISCLOSED HEREIN IS AND REMAINS THE PROPERTY OF AIR-SHIELDS INC. AND MAY NOT BE DISCLOSED TO ANY THIRD PARTY WITHOUT THE EXPRESSED WRITTEN CONSENT OF AIR-SHIELDS INC.

UNLESS OTHERWISE SPECIFIED, DIMENSIONS ARE IN INCHES. TOLERANCES ON: DECIMALS ANGLES ± .010 ± .005

SIGNATURES	DATE
V. YARNELL	14 OCT 93
V. KRAVETS	25 OCT 93

ALL SURFACE FINISH LAX.

DO NOT SCALE DRAWING

FIRST USED ON: 68 383 70, 71

Air-Shields
330 Jacksonville Road, Harboro Pa. 19040

SCHEMATIC, DISPLAY BD. C400/450

SIZE D 68 383 15

SCALE NONE SHEET 1 OF 1

TES:
 .INSTALL J14 AND R1,R2,R3 PER:

J11	R1	R2	R3
17 734 77	NO	NO	YES
17 734 19	YES	YES	NO

68 382 70
 68 382 71

PARTS LIST				REVISIONS	
ITEM NO.	DWG NO.	IDENT NO.	DESCRIPTION	QTY	U/M
				1. ISSUE:DRN 882-1	
				VY 14 OCT 93 14	
				2. ECN 10858 REV. & REDRAW	
				DU 09 MAR 94 15 APR 94	
				3. ECN 11117 (B4)R6 VALUE WAS 10K	
				DU 08 AUG 94 18 4uF	

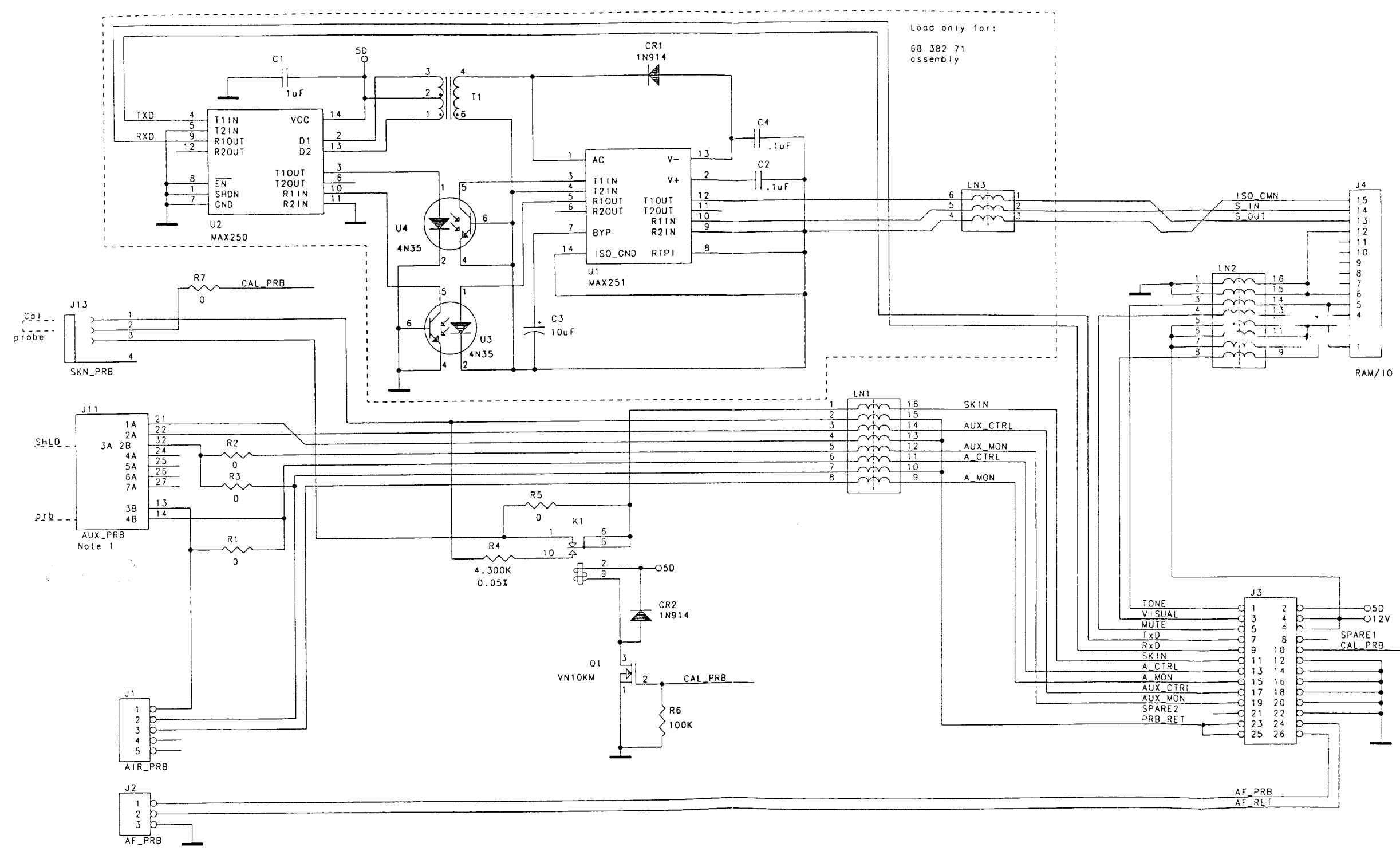

LAST CMPNT USED	THIS DOCUMENT CONTAINS CONFIDENTIAL AND PROPRIETARY INFORMATION. ALL INFORMATION DISCLOSED HEREIN IS AND REMAINS THE PROPERTY OF AIR-SHIELDS INC. AND MAY NOT BE DISCLOSED TO ANY THIRD PARTY WITHOUT THE EXPRESSED WRITTEN CONSENT OF AIR-SHIELDS INC.	UNLESS OTHERWISE SPECIFIED- DIMENSIONS ARE IN INCHES. TOLERANCES ON: FRACTIONS DECIMALS ANGLES ± .XX ± .XXX ± .XXX ±	SIGNATURES	DATE	Air-Shields 330 Jacksonville Road, Hatboro Pa. 19040
USED	OMITTED		DRWN V. YARNELL	14 OCT 93	
C4			CHEK		SCHEMATIC, PROBE 50., C400/450
CR2			ENC V. KRAVETS	25 OCT 93	
J13			APVD		SIZE D 68 382 15
LN3					
R6	FIRST USED ON:	DO NOT SCALE DRAWING	FINISH		SCALE NONE SHEET 1 OF 1
T1	68 382 70,71	MATERIAL			
U4					
Q1					
K1					