

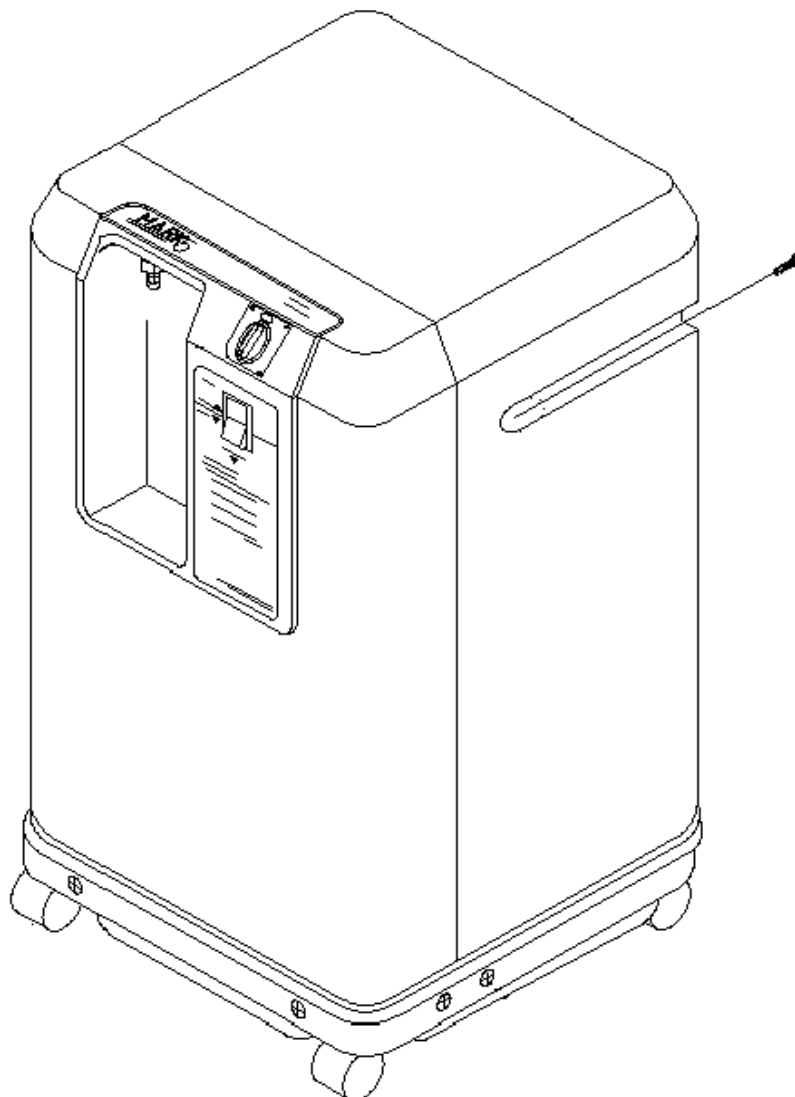

Mark 5 Plus Oxygen Concentrator Domestic Models –115V; 60Hz

Configurations 1373-31100 and 1373-71100 (Part 1)
Configurations 1373-31103 and 1373-71103 (Part 2)





Mark 5 Plus Oxygen Concentrator Domestic Models –115V; 60Hz

Configurations 1373-31100 and 1373-71100 (Part 1)
Configurations 1373-31103 and 1373-71103 (Part 2)

Introduction.....	1-1
Specifications.....	1-1
Safety Information.....	1-2
Principles of Operation.....	1-3
Pneumatic Diagram.....	1-4
Component Function.....	1-4
Initial Setup Instruction.....	1-5
Precautions and Safe Practices.....	1-6
Preventive Maintenance.....	1-7
Trouble Shooting.....	1-8
Test Port Diagram.....	1-8
System Diagnosis Chart.....	1-9
Trouble Shooting Guide.....	1-10
Component Replacement.....	1-11
Reference Material	
Electrical Schematic.....	1-13
Illustrations and Part Numbers.....	1-14

Oxygen Monitoring System Information

② See Section Two

Price List/Sample Forms/Reference Material

③ See Section Three

Nidek Medical Products, Inc.
3949 Valley East Industrial Drive
Birmingham, AL 35217 U.S.A.
(800) 822-9255
Phone (205) 856-7200
Fax (205) 856-0533



Introduction

Thank you for purchasing the *Mark 5 Plus* Oxygen Concentrator.

The *Mark 5 Plus* Concentrator is the latest in the high quality Mark series of concentrators manufactured by Nidek Medical Products, Inc. It is a reliable concentrator, requiring very little maintenance and is designed to operate efficiently for a long period of time. We have accomplished this by combining real world experience with the latest of control and process technology.

We believe that the *Mark 5 Plus* is the best machine available in today's market and will operate to your complete satisfaction. We invite your comments on our devices and our service. The Mark5 Plus is manufactured under the controls of FDA-GMP's and ISO-9001 and EN46001 Quality Management Systems.

Anand Chitlangia
President & CEO
Nidek Medical Products, Inc.

This edition of the Mark5 Plus Maintenance Manual is effective for configuration models 1373-31100 and 1373-71100 beginning with serial number 992-18378. See Section 2 for configurations 1373-31103 and 1373-71103.

Specifications (Stated at 70°F (20° C) and 1 Atm.)

Height.....	26 in / 660 mm
Width.....	15 in / 380 mm
Depth.....	15 in / 380 mm
Weight.....	60 lbs / 27 kg
Output.....	90% +/- 3% @ 5 lpm
Voltage.....	115 V; 60 Hz
Average Power Consumption.....	420W @ 60 Hz
Cooling Air Temperature Rise.....	Less than 30°F / 16°C

Safety

Oxygen Safety

Oxygen does not burn, but it does cause fire to burn more rapidly. Any material that will burn in air will ignite more rapidly and burn more violently in an oxygen-enriched atmosphere. While the oxygen concentrator does not contain a large volume of oxygen at any one given time, oxygen hazards can occur. If the output is allowed to return to the atmosphere no real hazard is likely; however, if the output hose is under a chair cushion or a pile of shop rags, these materials may become saturated with oxygen and could burn violently if ignited. The possibility of fire is the most serious hazard associated with the use of oxygen equipment. Observe the following precautions to prevent the possibility of a fire occurring in the vicinity of the oxygen outlet from this unit.

CAUTION

Eliminate Sources of Flame, Heat and Sparks

A fire can be started by almost anything that produces flame, heat and sparks. Do not permit the use of matches, cigarette lighters, burning tobacco, candles, or other flame sources in rooms where oxygen is used or stored. Electrical heaters or equipment that gets hot or sparks during operation can be a source of ignition.

Keep Flammable Materials Away From Oxygen

It is not possible to completely eliminate the presence of combustible materials such as clothing, bedding, and even parts of the therapy equipment itself, but the presence of highly flammable materials can and must be avoided. Do not lubricate oxygen equipment. Oil and grease, including petroleum jelly such as Vaseline™ ignite very easily and burn vigorously in the presence of oxygen.

Prevent Accumulation of Oxygen

Since any material that will burn in air will burn more vigorously in an oxygen-enriched atmosphere, prevent any local accumulation of oxygen that may saturate combustibles. All connections on the apparatus should be made carefully and observed for leakage.

Principles of Operation

The *Mark 5 Plus* Concentrator takes in room air that contains 21% oxygen, 78% nitrogen and trace amounts of inert gases. The air is filtered, compressed and passed through one of the two molecular sieve beds which allows the oxygen to pass but traps most of the nitrogen. Before the nitrogen saturates the molecular sieve in the first bed it is vented to the atmosphere and purged with oxygen while air is fed to the second bed. This process of alternate feeding and venting of beds is continued thus producing oxygen enriched gas at one end and exhaust at the other end of the sieve beds. The oxygen produced is then filtered, regulated, and set at a given flow rate for delivery to the patient.

The operation of the *Mark 5 Plus* can be grouped into three distinct systems; the *compressed air system*, the *process system* and the *delivery system*.

Compressed Air System

Air enters the system through filters which prevent dust and other particles from entering and potentially damaging the air compressor. The compressor is a reciprocating two cylinder positive displacement type that compresses the air to the necessary pressure. The compressed air is then routed through a heat exchanger to reduce its temperature and then to the air surge tank. The surge tank reduces air pressure swing and traps moisture. The wick assembly, located at the bottom of the surge tank, allows the moisture to be evaporated to atmosphere. The system also has a safety relief valve to prevent pressure buildup should a blockage occur and a test port for measuring system pressure.

Process System

The process system consist of two sieve beds and a rotary poppet valve. The valve controls the process by alternately feeding air into and exhausting nitrogen from the sieve beds. The valve utilizes a gear motor to cause a cam action to alternately open and close feed and exhaust poppets. Thus, what normally is a complex control system in other concentrators is reduced to a simple and easily understandable mechanical control in the *Mark 5 Plus*.

Delivery System

The cyclic process described above causes pressure variations in the oxygen as it exits the beds. In order to provide a stable flow, the oxygen, after passing through a bacterial filter to remove any contaminants, is passed through a regulator to establish a fixed delivery pressure. A flow control valve consisting of multiple orifices then establishes a fixed flow rate to the patient. The use of a vacuum relief breaker and check valve in this section prevents the possibility of contaminants entering the system from the outside. Two pressure switches monitor the oxygen pressure and cause an alarm to sound if the pressure is high or low. An Oxygen Monitoring System for continuously monitoring oxygen purity is available as an option. The operation of the Oxygen Monitoring System is described separately in Section ② .

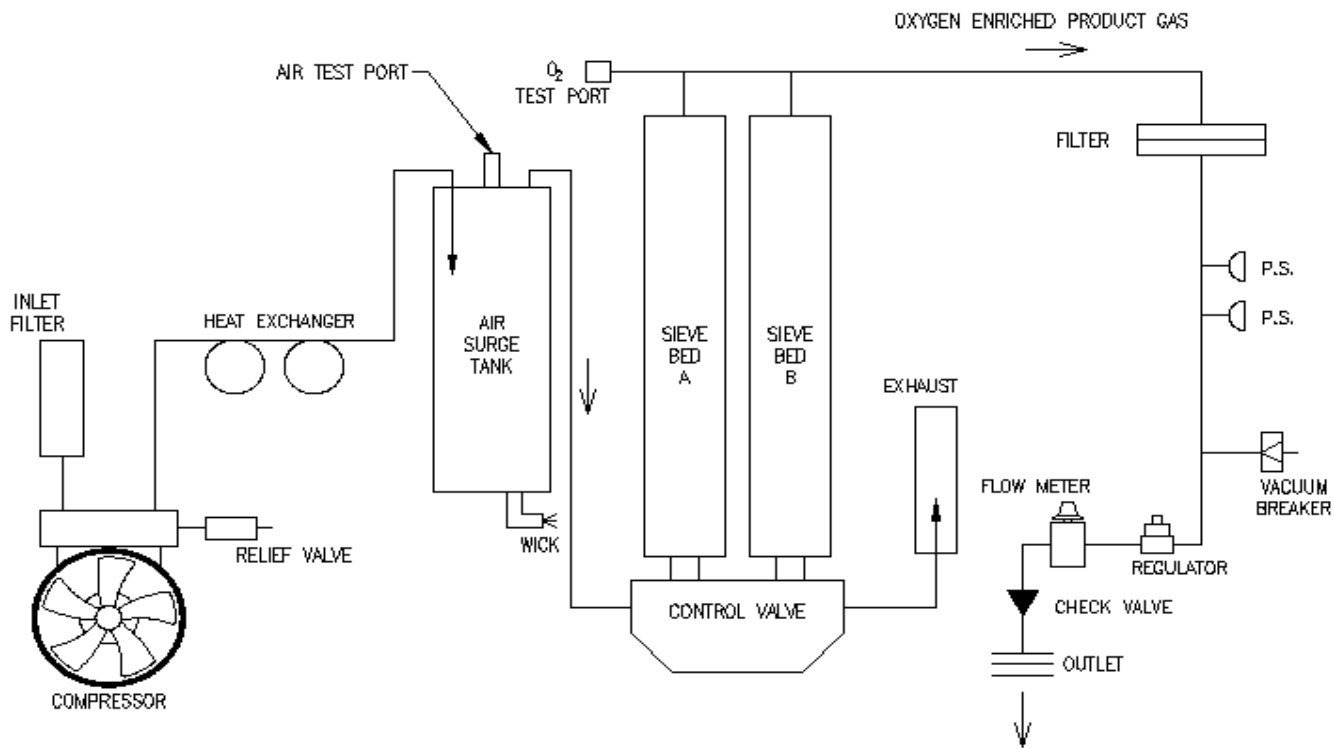

Component Function

A brief description of the principal function of each of the major components is provided below:

CABINET FILTER.....	Filters dust from cooling air
INLET FILTER.....	Filters Particles To Protect Compressor
COMPRESSOR.....	Pumps Air Into The System
RELIEF VALVE.....	Safety Device To Limit System Pressur
HEAT EXCHANGER.....	Cools Air After Compression
WICK ASSY.....	Removes Moisture from the Compressed Air
AIR SURGE TANK.....	Reduces air pressure fluctuations
AIR TEST PORT.....	A Connection For System Testing
ROTARY POPPET VALVE.....	Controls The Pressure Swing Process
SIEVE BEDS.....	Separates Gases As Air Is Moved In And Out
MUFFLER.....	Reduces Exhaust Noise
OXYGEN TEST PORT.....	A Connection For System Testing
PRESSURE SWITCHES.....	Activates Alarm For High Or Low Pressure
BACTERIAL FILTER.....	Removes contaminant from oxygen
VACUUM BREAKER.....	Prevents System Vacuum
REGULATOR.....	Sets A Fixed Output Pressure
FLOW CONTROL VALV..E.....	Sets The Flow Rate To A Specific Flow
CHECK VALVE.....	Prevents Any Reverse Flow Into The System
OUTLET.....	Provides A Connection For Hose Or Humidifier

Operating Instructions

The operating instructions for the *Mark 5 Plus* Concentrator are provided in a separate booklet written for the patient's use. Maintenance personnel must make themselves familiar with the contents of this book and use it for all questions that relate to the operation of the unit.

Initial Setup

Preparing a new *Mark 5 Plus* Concentrator for patient use consists of little more than taking it out of its shipping carton. After completing the Carton Unpacking Instructions found in the shipping carton follow these important checks to insure that shipping damage has not occurred and unit is performing properly.

Step One: Flow Control Limit Adjustment

The flow control setting on the *Mark 5 Plus* Concentrator may be locked to limit the maximum output available to the user. This limit is preset at the factory to 5 liters per minute but may be changed to any flow setting. From the front of the unit remove the flow control knob by pulling the knob straight off its shaft. The back of the knob assembly has a flow locking disc. To reset the flow, remove the screw from the locking disc, lift and rotate the disc in the desired flow setting, reinstall the screw and replace the flow control knob.

Step Two: Alarm Test

Before connecting power to the unit, press the ON button to test the battery and power failure alarm. It should sound when the switch is on and the power disconnected. If there is no alarm, check the 9-volt battery inside the front cabinet on switch plate and replace if necessary.

With the unit is plugged-in, push the ON button. The audible alarm should sound and the Service Required light should be lit and the compressor should run. After approximately 15 seconds both the alarm and the Serviced Required light should turn off.

Step Three: Purity Test

With unit running connect an oxygen Analyzer (Example: OxyChek®) to oxygen outlet and verify results of 90% +/- 3% @ 5 LPM.

Mark 5 Plus Oxygen Concentrator is ready to be placed in service.

Precautions and Safe Practices

The following precautions and safe practices are specifically directed to personnel who are experienced in the service of medical oxygen equipment. The device covered by these instructions is an electro-mechanical device that deserves all the respect inherent in servicing such equipment. Operation of this equipment also requires an awareness of all the potential hazards associated with handling and using oxygen.

Maintenance Safety

Maintenance personnel must be properly trained in the service of oxygen concentrators. Electrical shock hazards exist inside the cabinet of this equipment. Good shop practices must be observed at all times.

Use only approved replacement parts. Medical oxygen equipment should be repaired with parts supplied by the manufacturer. Substitution of unauthorized parts can effect the performance of the unit. All parts that will come in contact with oxygen must be thoroughly cleaned. Remember, human health is affected by the end product of this device and a foreign substance left by maintenance could be inhaled by a patient. Thread sealant and lubricants used on oxygen equipment must be of approved quality for such use.

Always follow printed instructions when maintaining or repairing this equipment. Repair procedures may involve special techniques that must be followed when performing such work.

WARNING

The sieve beds of the concentrator covered by these instructions contain a highly compressed spring. DO NOT ATTEMPT TO DISASSEMBLE a sieve bed or the spring may eject parts with dangerous velocity sufficient to cause personal injury.

Preventive Maintenance

To ensure proper performance of the Mark 5 Plus Oxygen Concentrator purity checks are recommended every three (3) months.

When operating under normal conditions the following maintenance schedule is recommended and should be followed for proper operation of the unit. In severe conditions such as high temperature, dusty and/or dirty atmosphere, it may be necessary to perform the maintenance functions at more frequent intervals. Where procedures are involved, they are shown elsewhere in this publication.

Preventive Maintenance Schedule Mark 5 Plus Oxygen Concentrator

	12 Months	24 Months	36 Months
Inlet Filter	X	X	X
Bacterial Filter	X	X	X
Battery	X	X	X
Muffler			X
Wick Assy			x
Compressor	Rebuild or perform maintenance when oxygen purity and/or operating pressure falls below minimum specifications.		

Note: In the Reference Material Section ③ of this manual we have provided a Maintenance Record Check List sample for your convenience.

Trouble Shooting

System Problem Diagnosis

With system problem isolation in mind, the *Mark 5 Plus* was designed with two test ports that allow the monitoring of the system pressures at two key points. The pressure swings / ranges at these test ports will provide important diagnostic clues when used with the SYSTEM DIAGNOSIS chart. Each port has a plug that is held into place by a quick disconnect fitting. The plug may be removed by depressing the ring around the plug. A suitable pressure gauge with $\frac{1}{4}$ diameter tube lead can then be connected to the quick disconnect fitting to measure the pressure swings.

Normal Pressure Swings Are:

*20 – 30 psig (140-205 kPa) at Air Test Port; 5 – 6 psig (35-42 kPa) difference between high pressure and low pressure

*10 – 15 psig (70-105 kPa) at Oxygen Test Port; 1 – 2 psig (7-15 kPa) difference between high pressure and low pressure

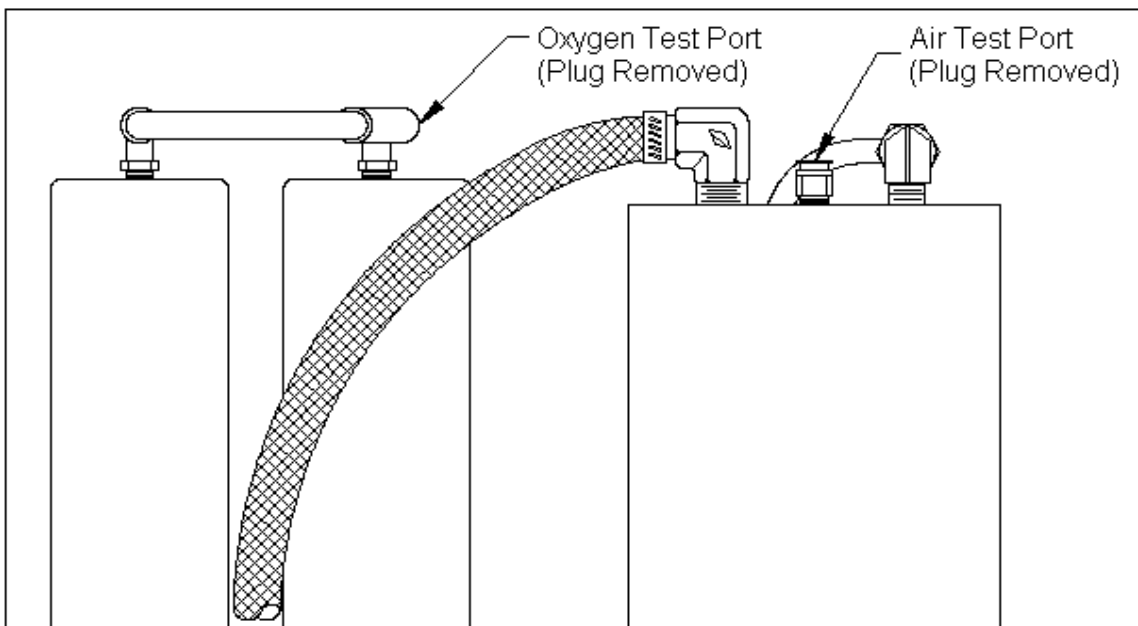

Note: To obtain accurate readings please observe the following check list.

1. Make sure that the filters are clean.
2. Leak test all fittings and repair all leaks (a leak will distort all measurements).
3. Make sure that the oxygen flow is set correctly at 5 lpm and that actual flow is 5 lpm with an accurate flowmeter..
4. Always be sure of the accuracy of your test instruments.

System Diagnosis Chart

Symptom	Possible Cause	Corrective Action
Power Failure Alarm	1) No Electrical Power	A) Check Power Source
Service Req'd Light	1) Low Oxygen Pressure 2) High Oxygen Pressure	A) See Trouble Shooting Guide
Low Product Flow	1) System Leak	A) Test Product Pressure B) Adjust Regulator
	1) Clogged Bacterial Filter	C) Change Inlet Filter
High Product Flow	1) Product Regulator	A) Test Product Pressure B) Adjust Regulator
Noisy Compressor	1) Worn Piston Seals 2) Rods or Bearings	A) Replace Piston Seals or Replace Compressor
Compressor Turns Off and Comes On	1) Compressor Thermal Overload Switch Activated Due to Overheating	A) Check Fan and Cooling Airway Path B) Replace Fan C) Replace Compressor
Fluctuating Flow	1) Dirty or Defective Regulator 2) Leak on Oxygen Side 3) Low Oxygen Pressure	A) Check Operation B) Clean or Replace Regulator C) See Trouble Shooting Guide

The trouble shooting guide which follows has been prepared to provide a logical sequence of measurements and evaluations that will lead to a probable conclusion as to the cause of a problem. As with all diagnostic efforts, the more highly trained and experienced individual is more likely to determine the root cause of any problem.

Troubleshooting Guide

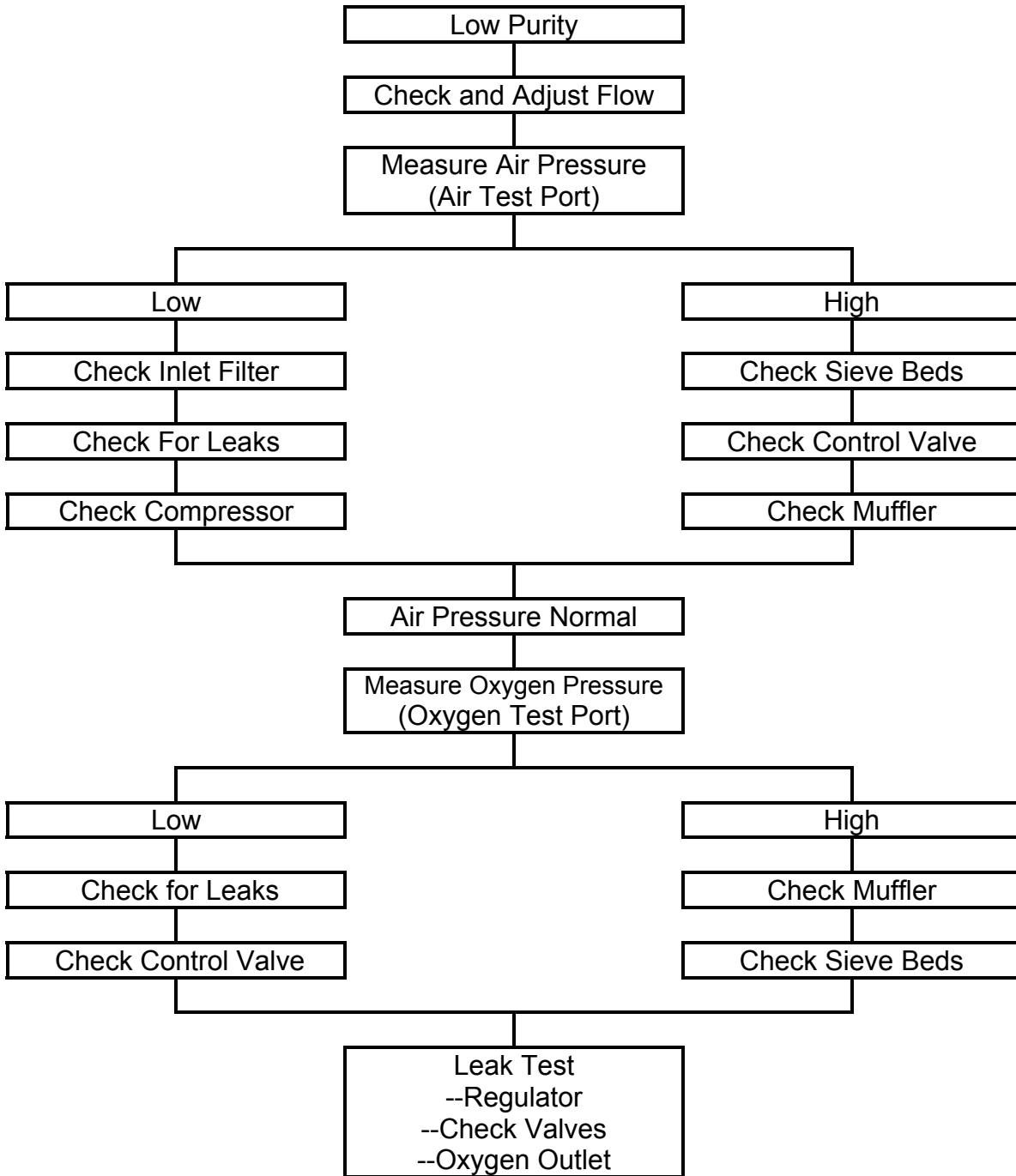

Repair Procedures

Compressor Replacement
(Compressor Model 2650CE37)

(Part # 7355-3535 – New)
(Part # 7355-3537 – Rebuilt)

Carefully follow the step-by-step procedure described below:

1. Disconnect concentrator from electrical source and remove front cabinet enclosure (2 Phillips head screws in the handle recesses; 4 screws around the base).
2. Remove front of the compressor enclosure (6 Phillips head screws).
3. Disconnect hose from the exhaust muffler located on the compressor front enclosure.
4. Disconnect the capacitor wires from the capacitor located on the compressor front enclosure.
5. Remove the inlet hose from the right side of the compressor
6. Loosen top hose clamp on left side of the compressor and remove the hose from compressor outlet fitting.
7. Remove the two Phillips head screws securing the compressor plate.
8. Clip the tie wrap above the compressor box enclosure that bundles the compressor electrical wires.
9. Disconnect the compressor electrical wires from the terminal block located on the top of the compressor box enclosure.
10. Slide compressor forward approximately 6 mm, lift up and pull out.
11. Remove all fittings including the relief valve.
12. Remove the compressor plate from the compressor by removing the four bolts holding the compressor and compressor plate together.
13. Reinstall replacement compressor in reverse order using thread sealant on metal fittings.
14. Check for leaks.

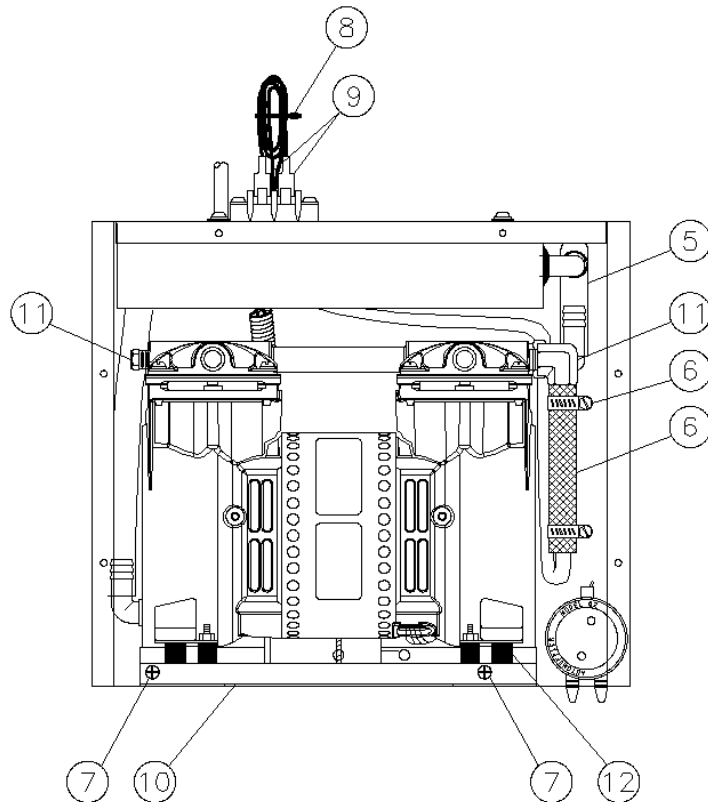

The Sieve Module Assembly in the *Mark 5 Plus* Concentrator consist of: *2 Sieve Beds, Gearmotor* and *Control Valve* and is replaced by removing the entire assembly. Carefully follow the instructions below.

1. Disconnect the gearmotor wires from the terminal strip.
2. Disconnect product line tubing.
3. Disconnect exhaust hose from fitting.
4. Pull open Velcro™ straps from sieve beds.
5. Remove the air hose from the back of the control valve by loosening the clamp.
6. Install in reverse
7. Check for leaks.

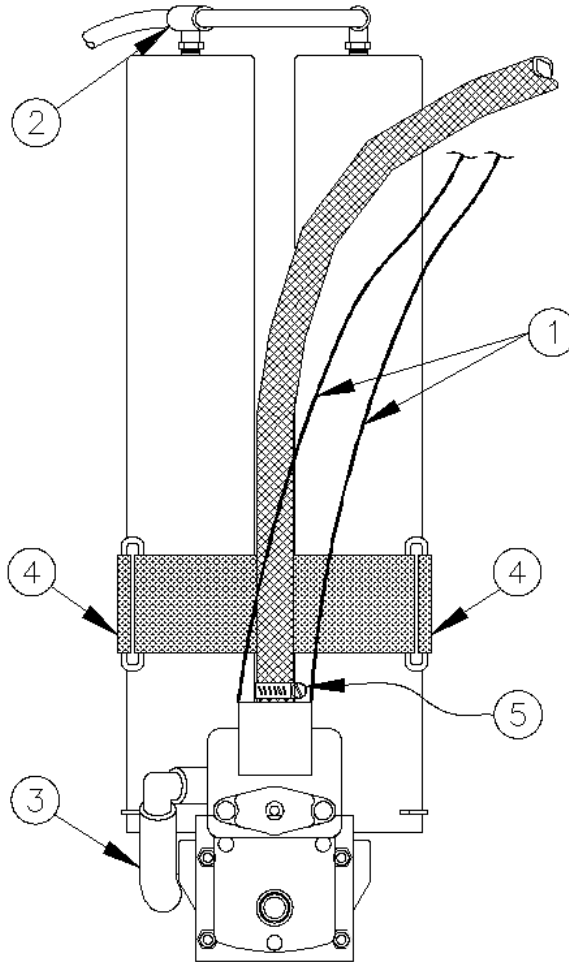

WARNING

The sieve beds of the concentrator covered by these instructions contain a highly compressed spring. DO NOT ATTEMPT TO DISASSEMBLE a sieve bed or the spring may eject parts with dangerous velocity sufficient to cause personal injury.

Electrical Schematic

Mark 5 Plus Oxygen Concentrator

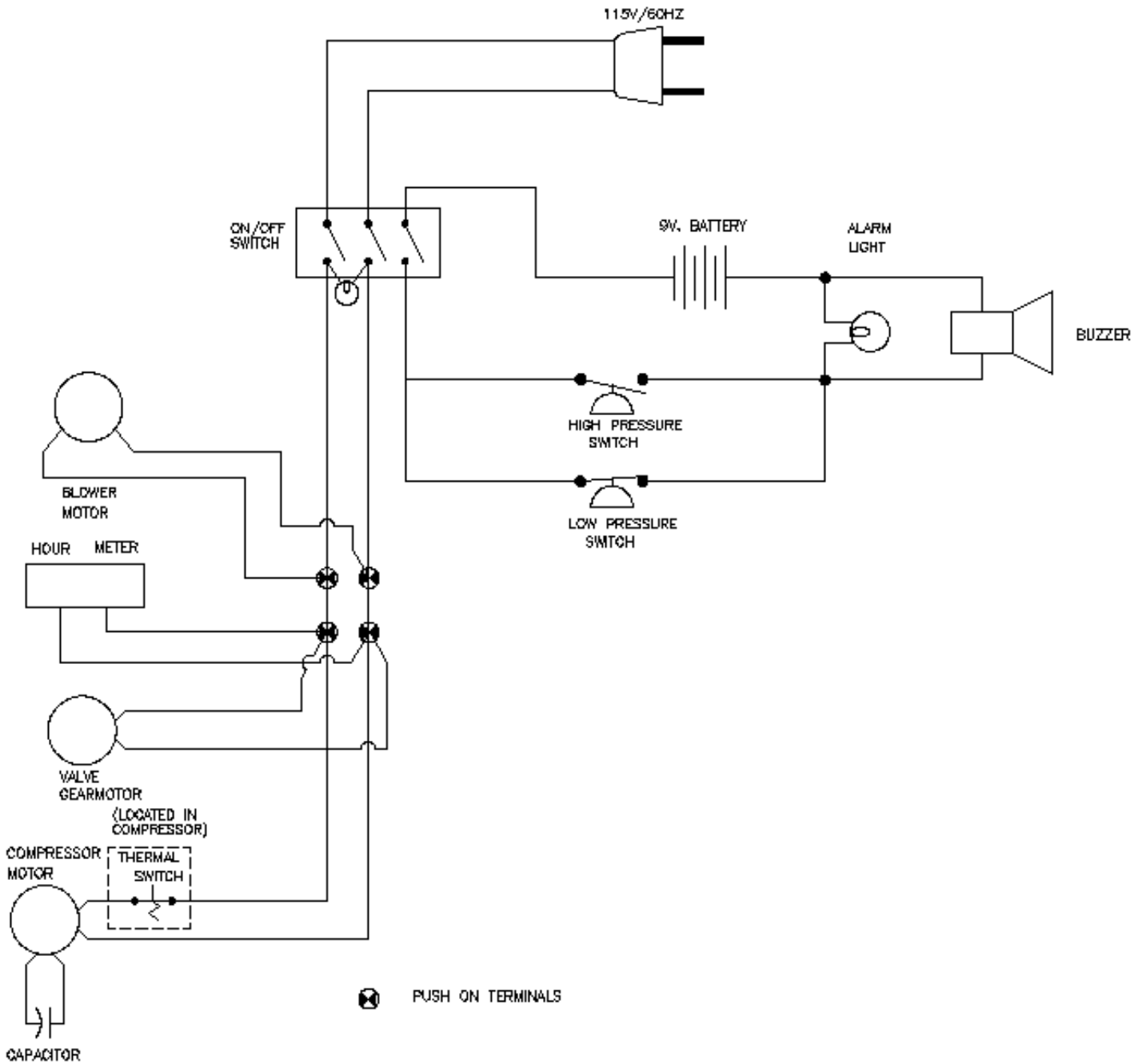

Parts Call-Out Illustration (Side View)

Mark 5 Plus Oxygen Concentrator

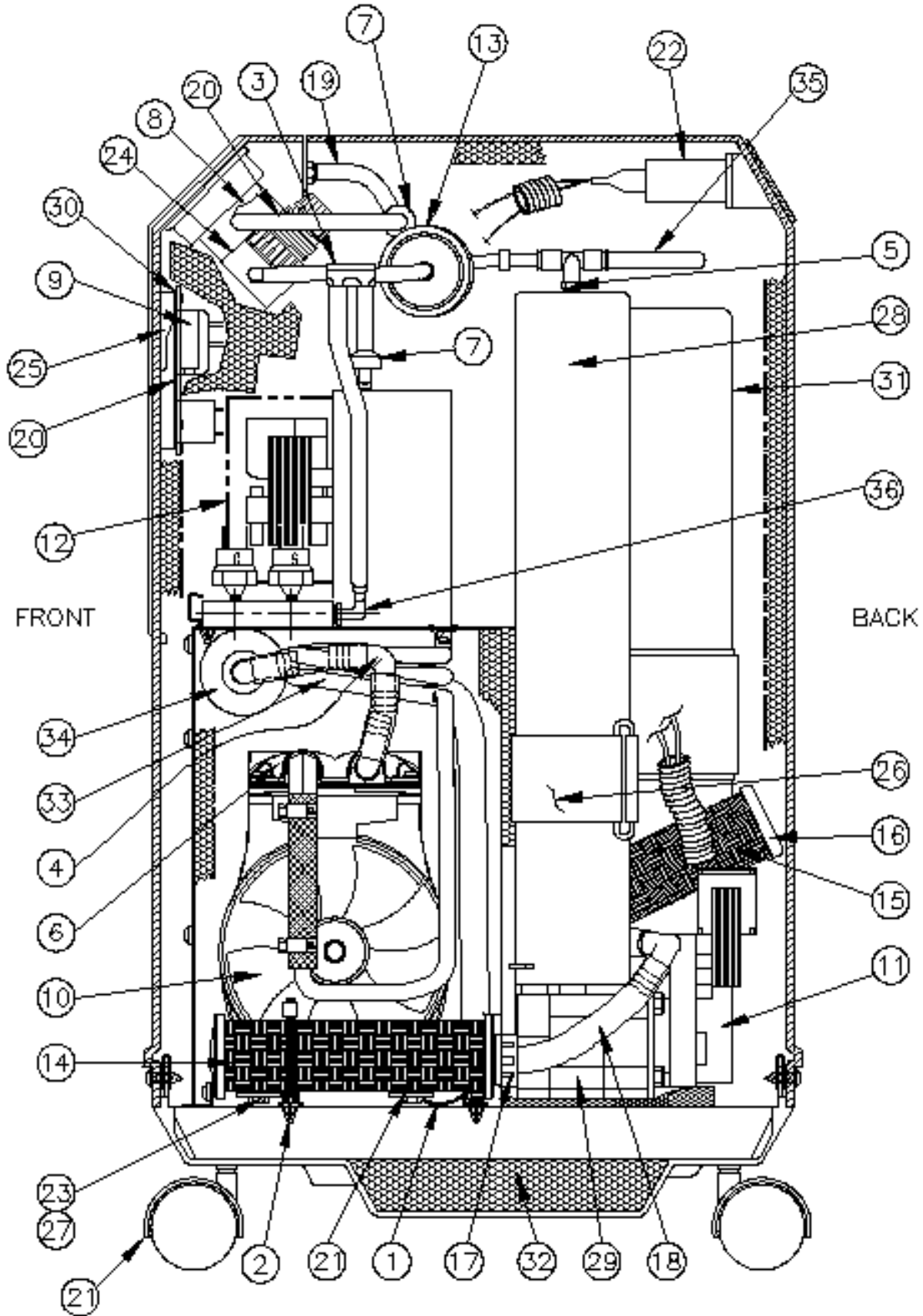

PARTS CALL OUT – SIDE VIEW

MODEL	ILL#	ITEM PART NUMBER	DESCRIPTION
1373-31110T	1	5161-1027	CAPACITOR 15 MFD
1373-71100	*	5161-1029	CAPACITOR RUBBER CAP
1373-71100C	2	5190-2233	TIE WRAP HOLDER
1373-71110	*	5190-2234	TIE WRAP 12 INCH LONG
1373-71110CA	3	6491-1005	CONNECTOR, 4-WAY, 3/16 BARB
1373-71100JM	4	6814-9228	ELBOW NYLON DOUBLE BARB ½ INCH
1373-71110T	5	6816-4162	TEE MALE BRANCH 1/8 NPT x ¼ ODT
1373-71110TB	6	6814-4183	ELBOW BRASS ¼ NPT x 3/8 HOSE BARB
1373-81110	7	6956-9673	CHECK VALVE / VACUUM BREAKER
	8	6998-9005	FLOW CONTROL VALVE (1/8 to 5 LPM)
		6998-9001	FLOW CONTROL VALVE (1/2 to 6 LPM)
	9	7206-0027	BATTERY 9 VOLT
	10	7355-3535	COMPRESSOR 115 V (NEW)
	*	7355-3537	COMPRESSOR 115 V (REBUILT)
	*	7355-3556	COMPRESSOR REBUILD KIT
	*	6953-9073	RELIEF VALVE 44 PSIG
	11	7500-0004	GEARMOTOR/VALVE ASSEMBLY
	*	7500-0003	GEARMOTOR ASSEMBLY
	12	7603-0005A	BLOWER ASSEMBLY
	13	7631-1053	BACTERIAL FILTER
	14	7631-1058	EXHAUST MUFFLER
	15	7631-1059	INLET FILTER
	16	7631-1063	CAP INLET FILTER
	17	7764-5587	BUSHING ¾ INCH
	18	7854-6110	HOSE BLUE PVC ¾ IN OD
	19	7854-6051	HOSE SILICONE 5/32 ID x 3 LONG
	20	7854-6049	HOSE SILICONE 5/32 ID x 8 LONG
	21	8300-8068	CASTER
	22	8316-5018	HOURLY METER ASSEMBLY
	23	8354-3071	VIBRATION ISOLATOR BLUE
	24	8816-1056	REGULATOR
	25	8986-0016	SWITCH ON/OFF
		8986-0023	SWITCH ON/OFF W/10A BREAKER(SCHURTER)
	26	9010-0G14	SIEVE BED STRAP VELCRO
	27	9010-8G03	SHOCK MOUNT KIT (COMPLETE)
	28	9012-8G06	SIEVE MODULE
	*	9012-5G00	SIEVE BED (NEW)
	*	9012-5G01	SIEVE BED (REBUILT)
	29	9012-7G00	CONTROL VALVE ASSEMBLY
	30	0450-0001	SWITCH PLATE ASSEMBLY (STANDARD SWITCH)
		0450-0011	SWITCH PLATE ASSEMBLY (SCHURTER)
	*	9114-9G14	SWITCH PLATE
	*	8230-9037	ALARM LIGHT
	31	9010-4G05	AIR SURGE TANK
	32	9114-6G37	CABINET BASE ASSEMBLY
	33	9114-6G20	DUAL COIL HEAT EXCHANGER
	34	9114-9G12	RESONATOR
	35	9077-7008	TUBING BLUE POLYURETHANE ¼ OD
	36	6491-1004	ELBOW 3/16 HOSE X 1/8 NPT NYLON

Parts Call-Out Illustration (Top View)

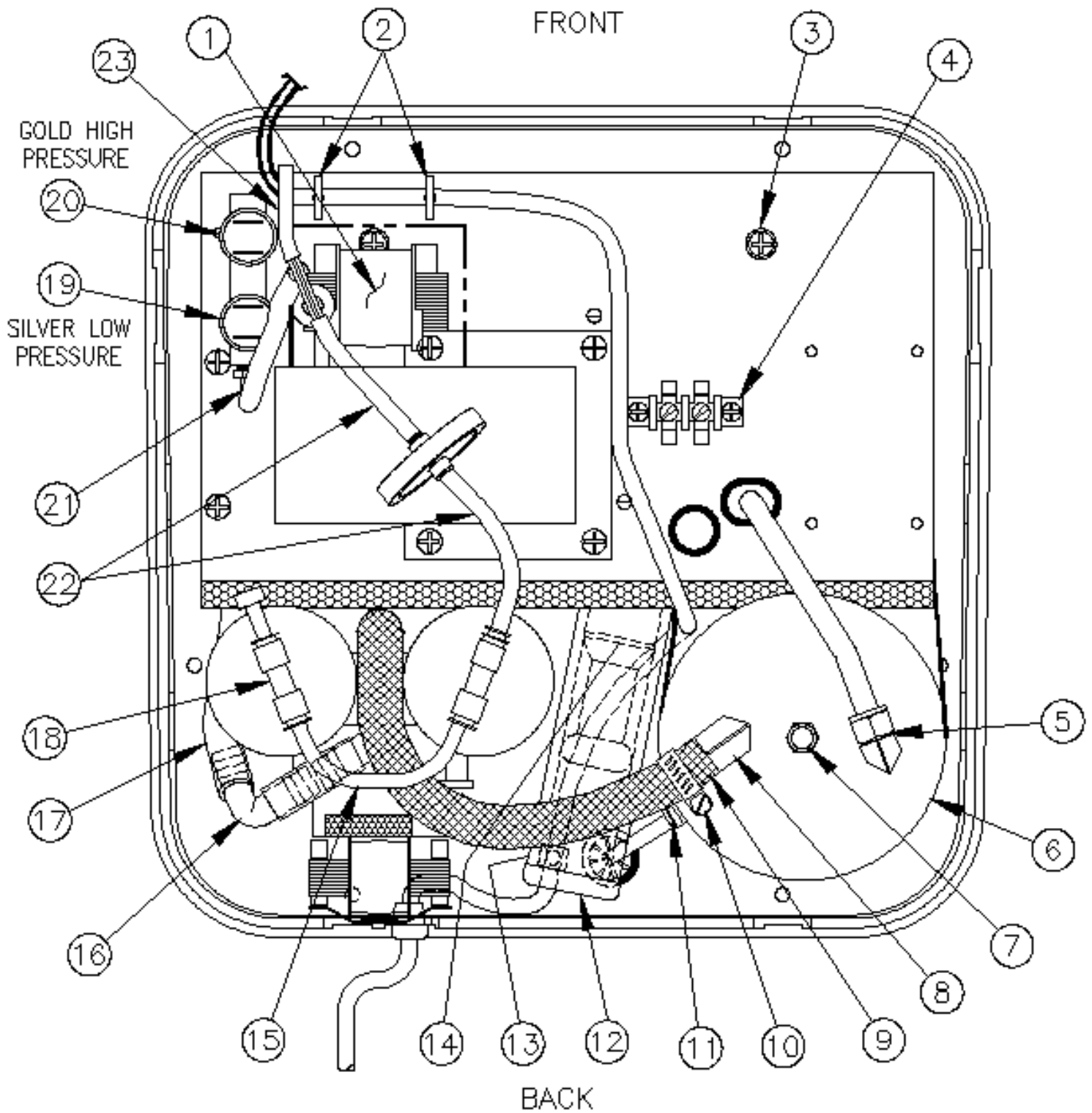

Parts Call-Out Illustration (Front Outside View)

Mark 5 Plus Oxygen Concentrator

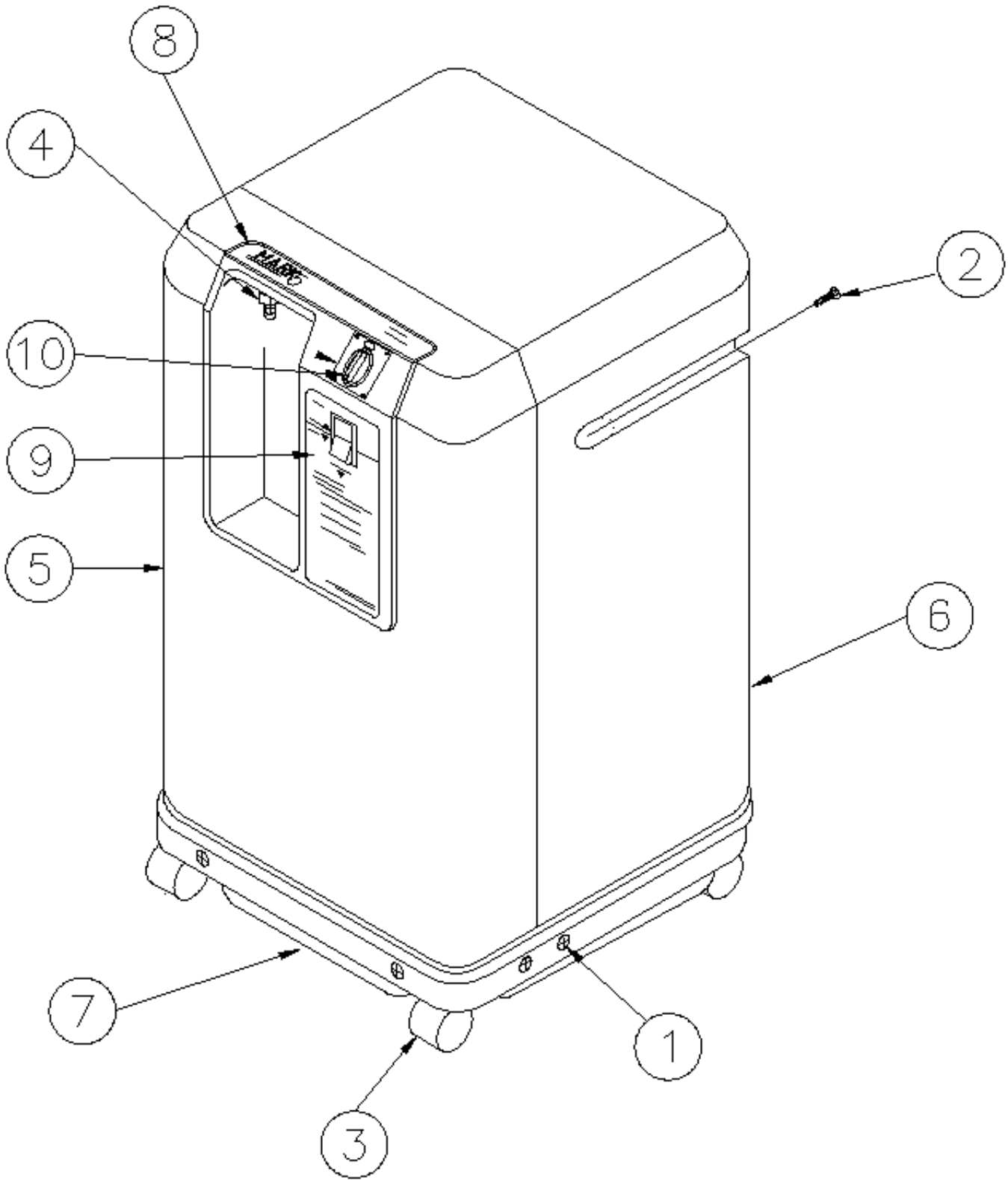

Parts Call-Out Illustration (Back Outside View)

Mark 5 Plus Oxygen Concentrator

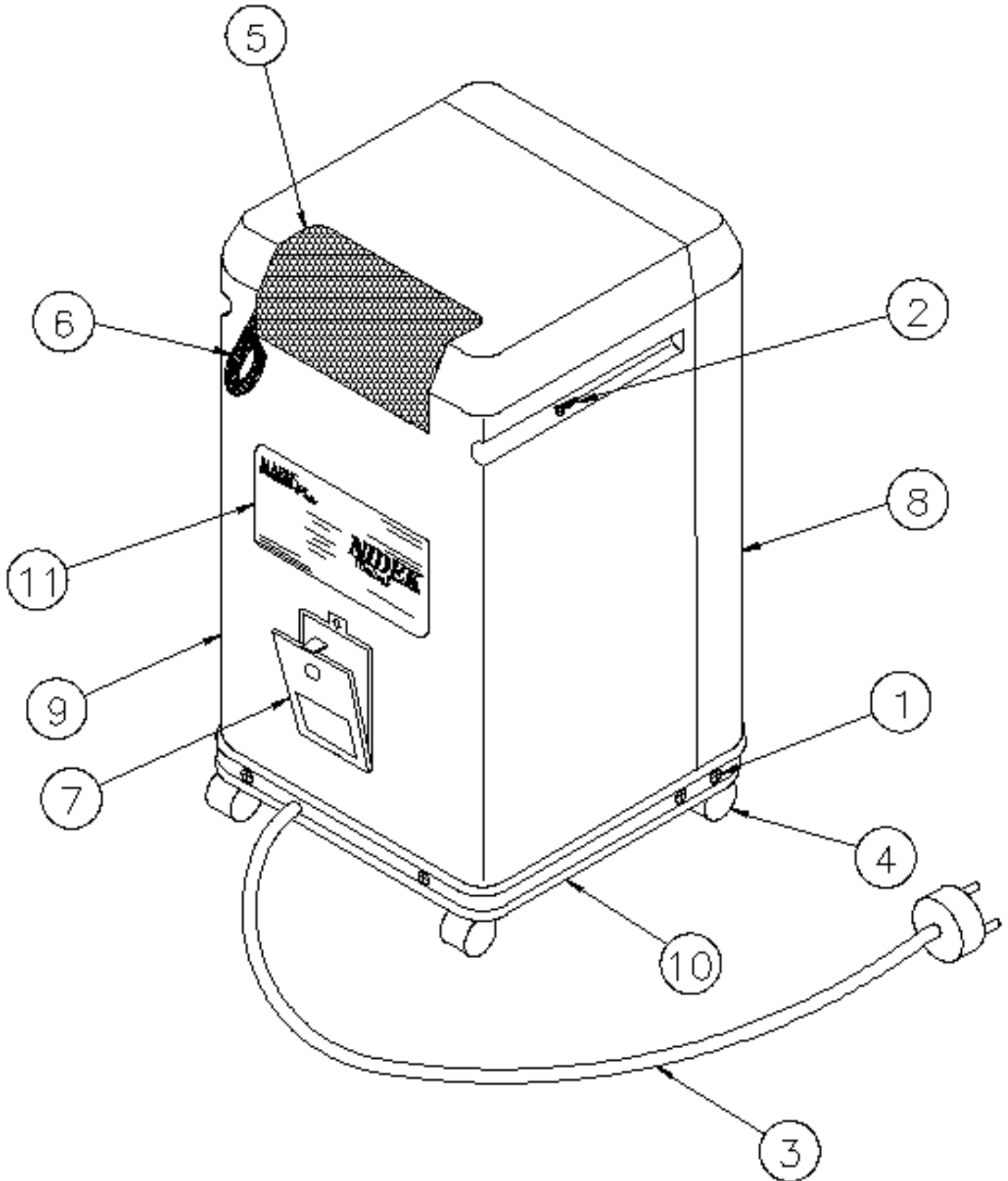

Operational Description for Oxygen Monitoring System

This portion of the manual is effective for configuration models 1373-31103 and 1373-71103 which are equipped with an Ultrasonic Oxygen Monitoring System. This is effective with for Oxygen Monitor equipped units beginning with serial number 98219700.

The Oxygen Monitor is an electronic module that continuously monitors the actual concentration of O₂ supplied by the **MARK 5 PLUS** concentrator. The Oxygen Monitor detects concentrations of 85% or below and triggers a visible and audible alarm. The Oxygen Monitor is available as an option. The Oxygen Monitor module reinforces and relays the standard operating alarms on the concentrator.

When powering on the **MARK 5 PLUS** the Oxygen Monitor module operates as below.

- In addition to the normal test of the **MARK 5 PLUS**, the Oxygen Monitor red indicator light comes on.
- The red indicator light may remain on for a few minutes (3 minutes maximum), which is the time necessary for the gas concentration supply to reach and exceed 85% O₂.
- The green indicator light comes on after this value is reached and the concentrator is then operating satisfactorily.

Operating principle

The oxygen monitor module is an electronic module that continuously monitors the oxygen enriched product that is actually supplied to the user.

The sensor, which utilizes the principle of sound velocity as a function of molecular weight, measures the velocity of sound in the product gas and compares it to stored values which correspond to the oxygen concentration. The preset threshold value is 85% for 115 volt devices.

A red light indicates a concentration below the preset threshold level. When the light is red for 15 minutes (± 2 minutes) a continuously audible alarm is activated.

The oxygen monitor module incorporates a 9V transformer, a pressure sensor, the oxygen sensor, a 9V battery, red and green LEDs, the alarm buzzer and associated electronic circuits.

Other alarms

Detection of absence of line voltage. In the event of a powerline cut, a continuous audible alarm is triggered (and the green LED goes out). The power supply for the alarm is a 9V battery.

Operating fault: In the case of a distribution malfunction (pressure of oxygen enriched air < 4 psig or > 20 psig) an audible alarm and visual alarm is triggered (red LED and continuous audible alarm).

Interfacing

The oxygen monitoring system is fully contained on the printed circuit board on which the ON/OFF switch is located. Electrical power is supplied to the board from the switch terminals to terminals E1 and E2 on the board. The transformer and rectifier located on the board converts the line supplied power to the 5 V dc and 12 V dc power that is required to operate the electronic parts. Battery supplied power is received from the battery mounted on the board. This is the extent of the power requirement.

The product gas interface to the board is achieved by routing the product gas, which is to be delivered to the user via the outlet fitting, from the flow control valve to the oxygen monitoring unit. All of the gas produced by the concentrator is routed through the analyzer. From the analyzer sensor tube, the gas is routed to the concentrator outlet fitting and then to the user. The analyzer is designed to operate at low pressures only. The gas supplied must always pass through the regulator and the flow control valve before being routed to the analyzer tube. Use caution to be sure that no gas with pressure greater than 5 psig is fed to the analyzer sensor tube assembly.

Additional to the regulated product gas being connected to the sensor tube, a signal of unregulated product gas is connected to the pressure sensor located on the printed circuit board. This provides the signal to sound the low or high pressure alarm.

Operation

The oxygen monitor is a single level oxygen monitoring system. The monitor is calibrated at both air and concentrator levels of oxygen concentration. The internal alarm switch is pre-set to a setting of 85 percent oxygen purity. When the concentration of the input gas drops below pre-set level, the red LED is lighted. If the concentration stays below the pre-set level for approximately 15 minutes, an audible alarm signal is generated. When the average purity is maintained above 85 percent for several concentrator cycles, the alarms are reset.

The process high and low pressure alarms are also included in the printed circuit board. It is no longer necessary to supply the high and low pressure switches in the product circuit.

Trouble Shooting

- 1 Connect mains power to terminals E1 and E2.
- 2 Connect concentrator product gas to the left barb on the sensor tube. Check the purity of the product gas at the outlet fitting.
- 3 Turn power on. The alarm should sound until product pressure exceeds 4 psig.
- 4 Allow unit to reach operating temperature before starting the test. (1-3 minutes).
- 5 When gas purity reaches 85 percent, the green LED should light.
- 6 Bleed off some product gas at the sieve bed to reduce purity. When the input gas concentration is below the pre-set level, the red LED should be lighted. After about 15 minutes, the audible alarm should sound.

Electrical Schematic

Mark 5 Plus Oxygen Concentrator with Oxygen Monitoring System

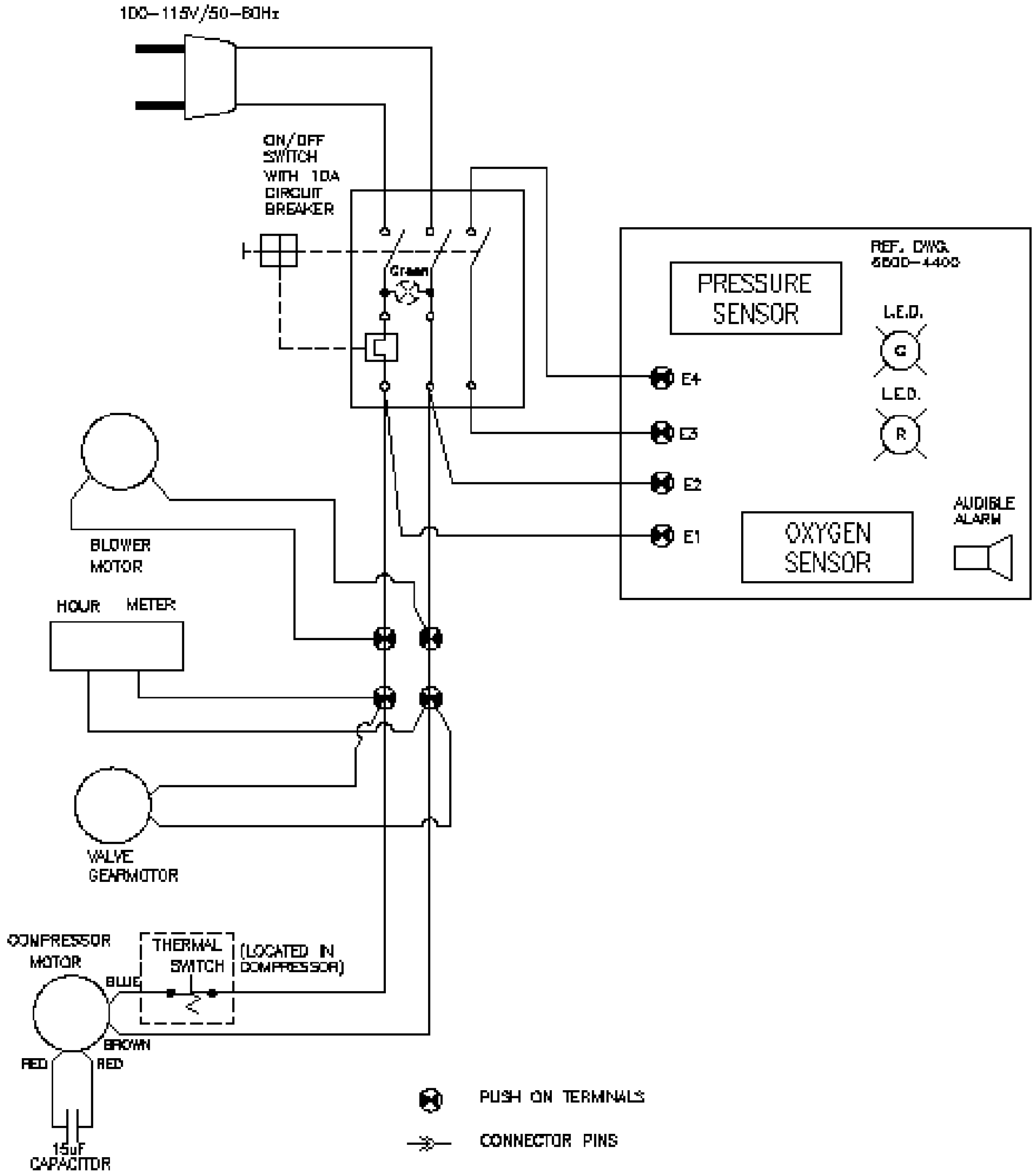

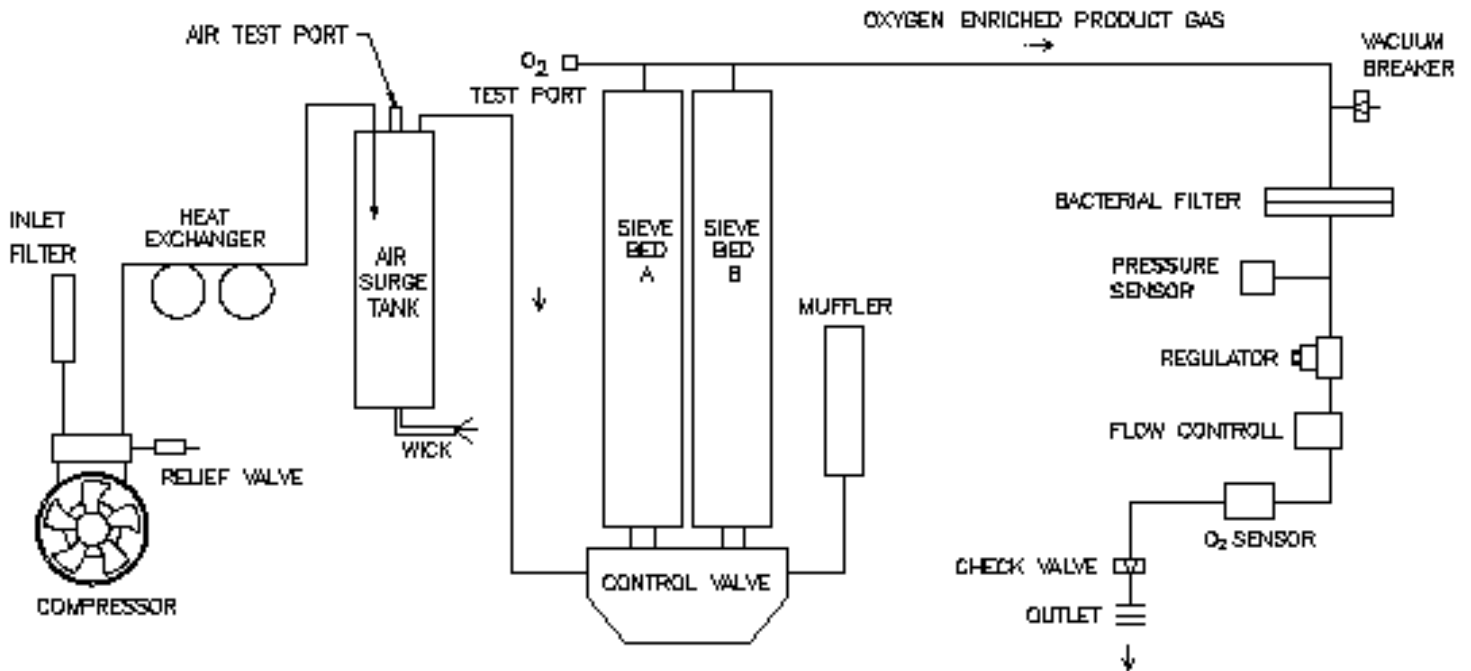

Pneumatic outline diagram with Oxygen Monitor System

Component Function

A brief description of the principal function of each of the major components is provided below:

- CABINET FILTER.....Filters dust from cooling air
- INLET FILTER.....Filters Particles To Protect Compressor
- COMPRESSOR.....Pumps Air Into The System
- RELIEF VALVE.....Safety Device To Limit System Pressure
- HEAT EXCHANGER.....Cools Air After Compression
- WICK ASSY.....Removes Moisture from the Compressed Air
- AIR SURGE TANK.....Reduces air pressure fluctuations
- AIR TEST PORT.....A Connection For System Testing
- ROTARY POPPET VALVE.....Controls The Pressure Swing Process
- SIEVE BEDS.....Separates Gases As Air Is Moved In And Out
- MUFFLER.....Reduces Exhaust Noise
- OXYGEN TEST PORT.....A Connection For System Testing
- PRESSURE SENSOR.....Activates Alarm For High Or Low Pressure
- BACTERIAL FILTER.....Removes contaminant from oxygen
- VACUUM BREAKER.....Prevents System Vacuum
- REGULATOR.....Sets A Fixed Output Pressure
- OXYGEN SENSOR.....Activates alarm for low purity
- FLOW CONTROL VALVE.....Sets The Flow Rate To A Specific Flow
- CHECK VALVE.....Prevents Any Reverse Flow Into The System
- OUTLET.....Provides Connection For Hose Or Humidifier

Preventive Maintenance

To ensure proper performance of the Mark 5 Plus Oxygen Concentrator purity checks are recommended every twelve (12) months or each time a unit is returned from a patient.

When operating under normal conditions the following maintenance schedule is recommended and should be followed for proper operation of the unit. In severe conditions such as high temperature, dusty and/or dirty atmosphere, it may be necessary to perform the maintenance functions at more frequent intervals. Where procedures are involved, they are shown elsewhere in this publication.

Preventive Maintenance Schedule Mark 5 Plus Oxygen Concentrator with Oxygen Monitoring System

	12 Months	24 Months	36 Months
Inlet Filter	X	x	X
Bacterial Filter	X	x	X
Battery	X	x	X
Muffler			X
Wick			X
Compressor	Rebuild or perform maintenance when oxygen purity and/or operating pressure falls below minimum specifications.		

The most frequent cause of low purity is that the air supply has been restricted. It is particularly important to be sure that the cabinet air filter is cleaned on a regular basis. If it is permitted to get dirty, it will reduce the amount of cooling air available to the machine which may result in premature loss of performance of the compressor and the sieve module.

Note: In the Reference Material Section ③ of this manual we have provided a Maintenance Record Check List sample for your convenience.

Parts Call-Out Illustration (Side View)

Mark 5 Plus Oxygen Concentrator with Oxygen Monitoring System

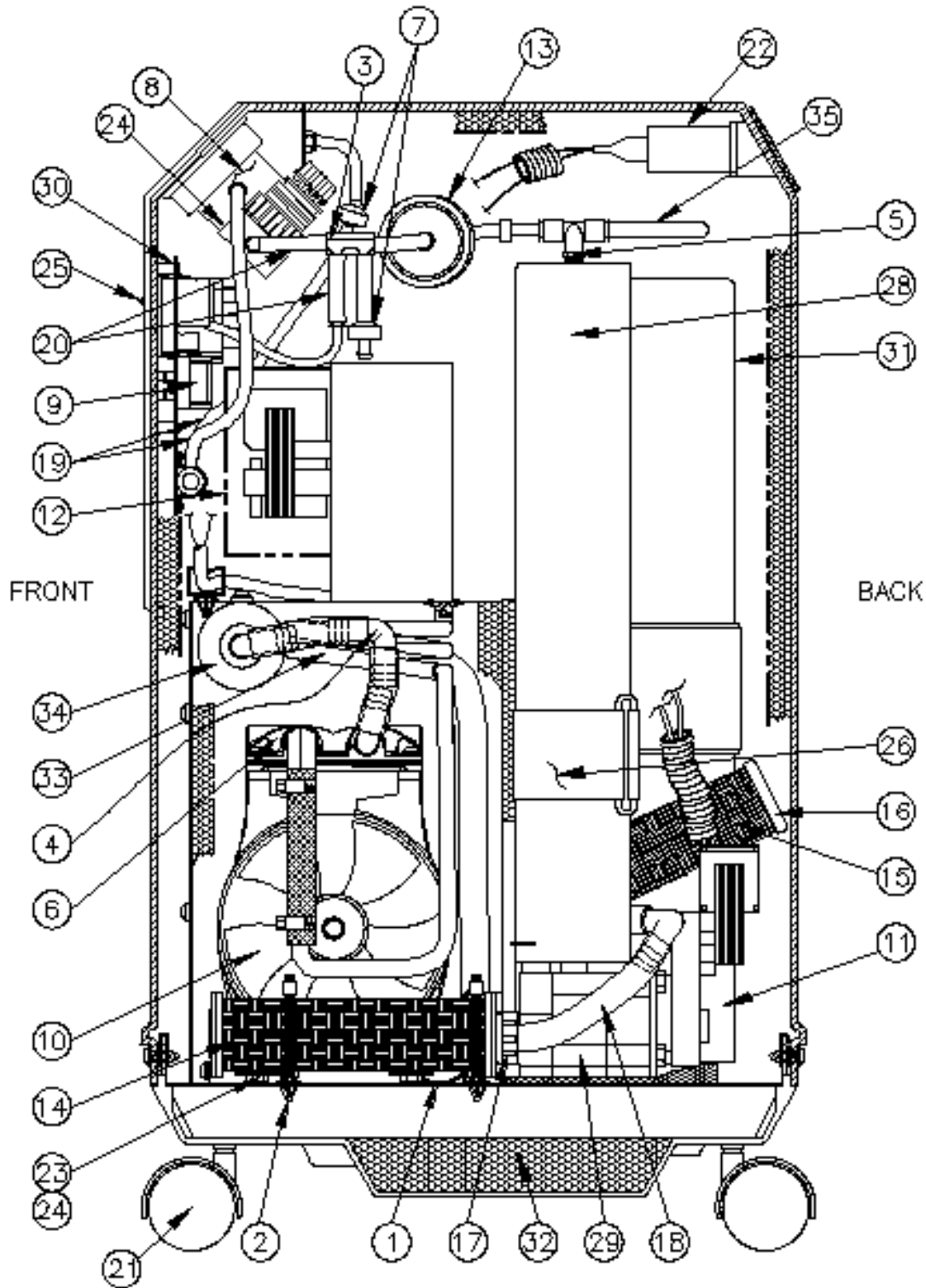

PARTS CALL OUT – SIDE VIEW

MODEL	ILL#	ITEM PART NUMBER	DESCRIPTION
1373-31110T	1	5161-1027	CAPACITOR 15 MFD
1373-71100	*	5161-1029	CAPACITOR RUBBER CAP
1373-71100C	2	5190-2233	TIE WRAP HOLDER
1373-71110	*	5190-2234	TIE WRAP 12 INCH LONG
1373-71110CA	3	6491-1005	ADAPTER BARBED NYLON 4 WAY
1373-71100JM	4	6814-9228	ELBOW NYLON DOUBLE BARB ½ INCH
1373-71110T	5	6816-4162	TEE MALE BRANCH 1/8 NPT x ¼ ODT
1373-71110TB	6	6814-4183	ELBOW BRASS ¼ NPT x 3/8 HOSE BARB
1373-81110	7	6956-9673	CHECK VALVE / VACUUM BREAKER
	8	6998-9005	FLOW CONTROL VALVE
	9	7206-0027	BATTERY 9 VOLT
	10	7355-3535	COMPRESSOR 115 V (NEW)
	*	7335-3537	COMPRESSOR 115 V (REBUILT)
	*	7355-3556	COMPRESSOR REBUILD KIT)
	*	6953-9073	RELIEF VALVE 44 PSIG
	11	7500-0004	GEARMOTOR/VALVE ASSEMBLY
	*	7500-0003	GEARMOTOR ASSEMBLY
	12	7603-0005A	BLOWER ASSEMBLY
	13	7631-1053	BACTERIAL FILTER
	14	7631-1058	EXHAUST MUFFLER
	15	7631-1059	INLET FILTER
	16	7631-1063	CAP INLET FILTER
	17	7764-5587	BUSHING ¾ INCH
	18	7854-6110	HOSE BLUE PVC ¾ IN OD
	19	7854-6049	HOSE MILKY SILICONE 5/32 ID x 8 LONG
	20	7854-6047	HOSE SILICONE 5/32 ID x 1.5 LONG
	21	8300-8068	CASTER
	22	8316-5018	HOURMETER ASSEMBLY
	23	8354-3071	VIBRATION ISOLATOR BLUE
	24	8816-1066	REGULATOR
	25	8986-0022	SWITCH ON/OFF W/5A BREAKER(SCHURTER)
	26	9010-0G14	SIEVE BED STRAP VELCRO
	27	9010-8G03	SHOCK MOUNT KIT (COMPLETE)
	28	9012-8G06	SIEVE MODULE ASSEMBLY
	*	9012-5G00	SIEVE BED (NEW)
	*	9012-5G01	SIEVE BED (REBUILT)
	29	9012-7G00	CONTROL VALVE ASSEMBLY
	30	6500-4400	OXYGEN MONITOR BOARD
	31	9010-4G05	AIR SURGE TANK
	32	9114-6G37	CABINET BASE ASSEMBLY
	33	9114-6G20	DUAL COIL HEAT EXCHANGER
	34	9114-9G12	RESONATOR
	35	9077-7008	TUBING BLUE POLYURETHANE ¼ OD

Parts Call-Out Illustration (Top View)

Mark 5 Plus Oxygen Concentrator with Oxygen Monitoring System

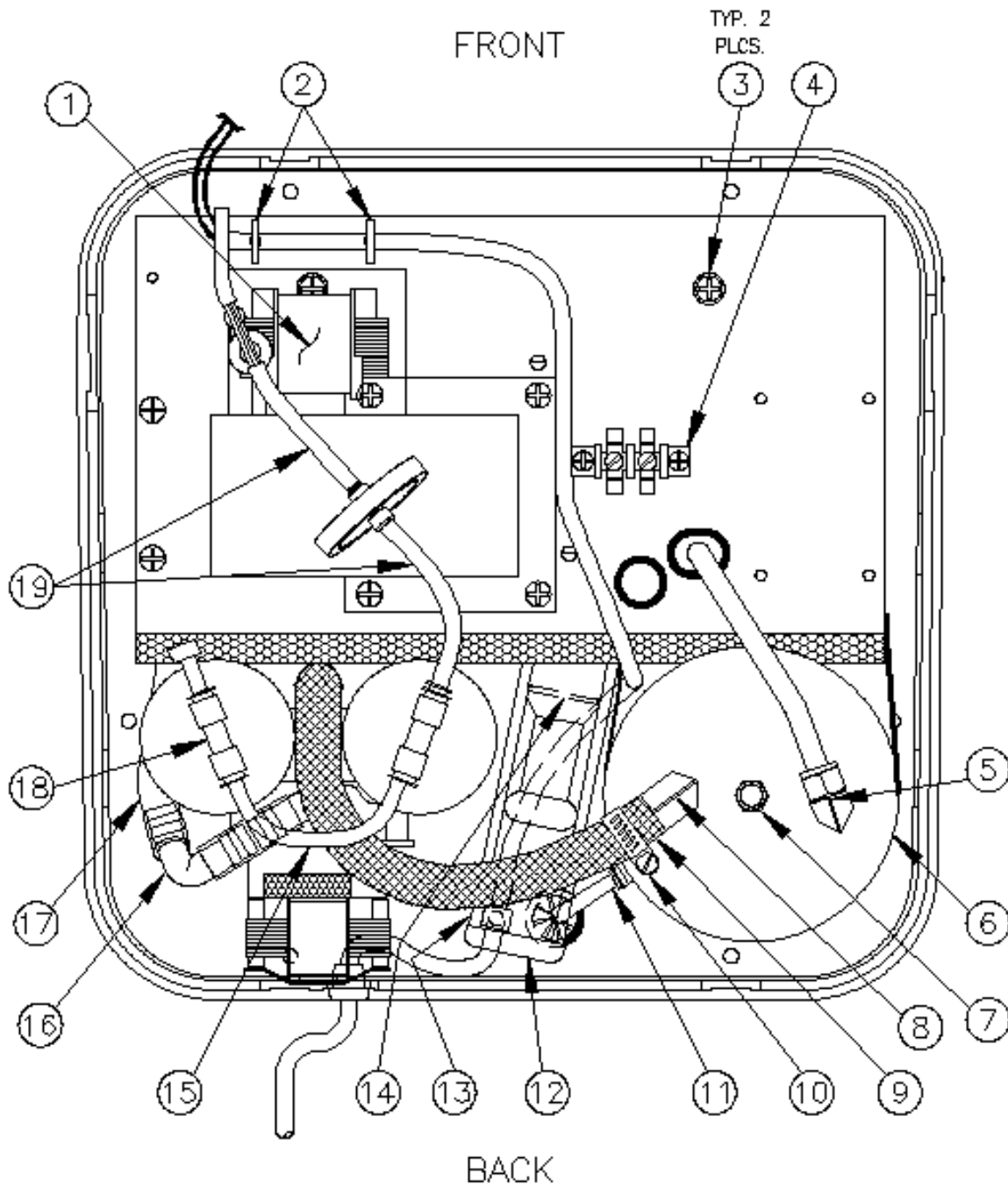

Parts Call-Out Illustration (Front Outside View)

Mark 5 Plus Oxygen Concentrator with Oxygen Monitoring System

