

ENDOLASER 476 SERVICE MANUAL

1476.773

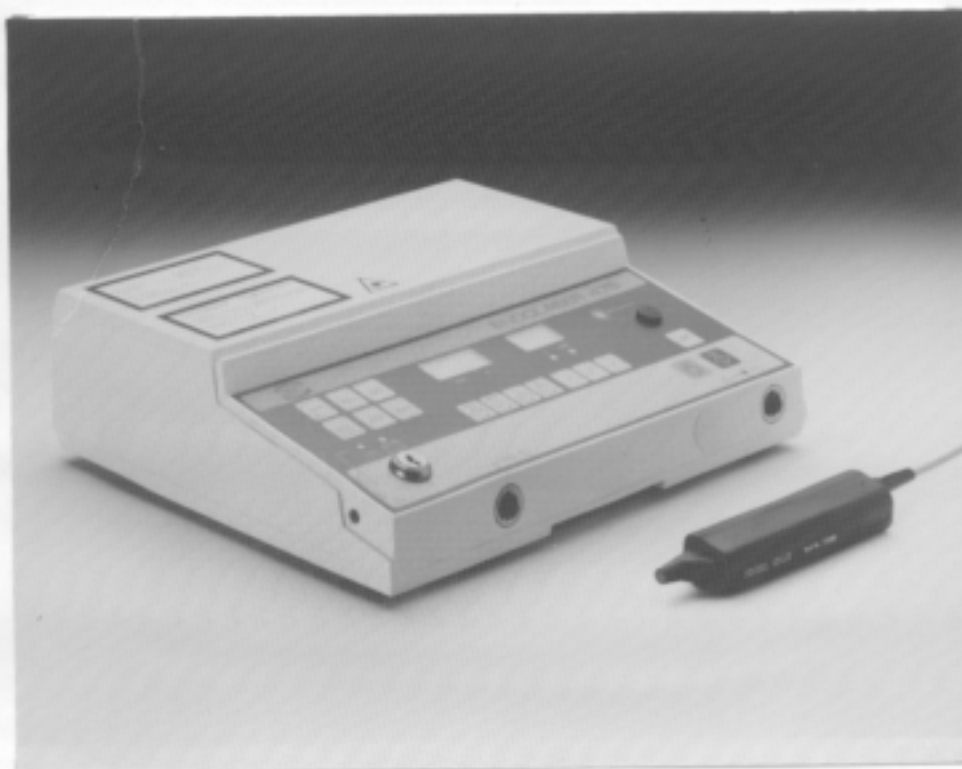

Edition: February 1993

Technical modifications reserved

PREMATORY NOTE

This manual is meant for authorized Enraf-Nonius service dealers.

We hope that this manual enables you to execute adequate service in the full sense of the word. If you have remarks and/or suggestions, please write to ENRAF-NONIUS B.V., Service Documentation Department, Medical Division, P.O.BOX 483, 2600 AL DELFT, HOLLAND.

The information in this manual has been carefully checked and is believed to be reliable. However, no responsibility is assumed for possible inaccuracies or imperfections.

Nothing from this document may be duplicated, copied and/or published in any way whatsoever, without prior written permission from B.V. ENRAF-NONIUS DELFT, DELFT, HOLLAND.

CONTENTS

[page 1]

1	General introduction	page 2
2	What you should know about laser	page 3
3	Technical data / dimensions	page 4
4	Operation	page 6
5	Block diagram description	page 12,13
6	Circuit description	page 14
	6.1 Sheet 1	page 14
	6.2 Sheet 2	page 14,15
	6.3 Sheet 3	page 16
	6.4 Sheet 4	page 16
	6.5 Sheet 5	page 17
	6.6 Sheet 6	page 17
	6.7 Sheet 7	page 17,18
8	Adjustments	page 19
9	Function test	page 20
10	Maintenance	page 21
	Service file	page 22
	Connectors-sockets-switches: pin to pin connections	page 23
	Housing, sectional drawing.	page 24
	Photo inside view.	page 25
	Battery charger	page 26
	Parts list	page 28
	How to order spare parts	page 34
	Parts list battery charger	page 35

Appendix A

Laserprobe servicing	page 36
--------------------------------	---------

Diagrams

sheet 1	endolaser 476 (processor circuit)	
sheet 2	powersupply, battery, keyswitch	series 0
		series 1
sheet 3	frequency divider	
sheet 4	display	
sheet 5	clickcircuit, buzzer, photoamp.	
sheet 6	keyboard	
sheet 7	led-drivers, interlock and probe connection	
sheet 8	probe and interlock connection	
sheet 9	PC Board, lay-out of components	

The Endolaser 476 offers two types of laser therapy: continuous and pulsed. Continuous laser therapy is generally used for the treatment of semi-acute and chronic disorders, while pulsed therapy is mainly used for the treatment of very acute conditions. The maximum output is determined by the probe connected, and the power can be set in four steps (25, 50, 75 and 100%).

Easy setting of dose and treatment time

The applied dose in joules (J) can be set extremely accurately, and is indicated on an LCD display. The Endolaser 476 automatically determines the required treatment time, and this is shown on a second display.

The procedure can also be reversed: a treatment time is set, and the unit shows what the applied dose will be. Treatment can be started using the start button on the probe, or the start button on the unit itself.

Laser probe with target indication

The treatment probes are fitted with a solid state Ga-As-Al laser with a wavelength of 780 or 830 nm, and power of 10 or 30 mW. The small diameter of the laser beam at the focal point, and the fact that light at this wavelength is barely visible, necessitate some indication of the target point. This problem has been solved by providing the laser probes with a target light which transmits visible light with the laser beam, clearly marking the point of treatment.

Microcomputer controlled with selftest and test mode function

The Endolaser 476 is equipped with a microcomputer that controls all functions and that performs a selftest upon power-up.

Tested at power-up and during operation are:

- the Eprom (checksum),
- the supply voltage,
- the probe analog voltage (probe driver signal).

In case of a fault the following is done:

- the probe is switched off,
- the timer display shows a colon (:)
- the energy display shows a dot (.)
- the unit is locked in this condition.

To escape, one can retry to power-up,

- * If the fault remains, internally a test jumper should be placed. The unit now escapes the locked condition making it possible to measure different signals in the unit at different settings.

- * Equipment of series 0 do not have this facility.

WARNINGS

- Never look directly into a laser probe. This can cause serious damage to the eyes.
- The operator has to be aware of the fact that the laserlight can be reflected, he or she should wear goggles as a protection against reflected laser light.
- Always follow these instructions when using the Endolaser 476 and the treatment probe. Failure to follow these instructions can lead to accidental laser emission.

Use of door switch (interlock connection)

Class 3B laser equipment must be provided (IEC825) with an remote interlock facility that makes it possible to interrupt the emission of laser energy when e.g. a treatmentroom is entered from outside.

National regulations may specify particular use of a door switch or other interlock function.

An interlock switch can be installed by the user, preferably as a door switch. The switch must incorporate a contact breaker.

- in the normal 'working' situation the contact is closed
- if the contact is broken, (door open), laser is automatically switched off.

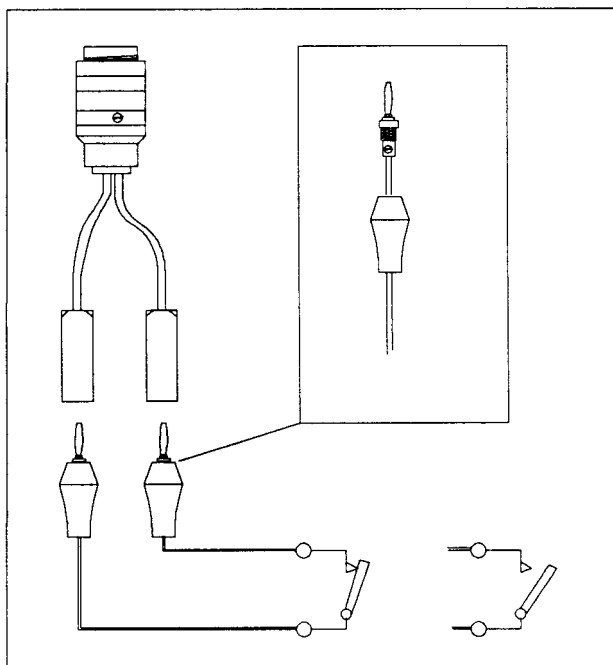

an interlock connector is provided for use in case a door switch is not required.

**On/off keyswitch**

It is recommended that the key should be removed from the Endolaser 476 when the unit is not in use, in order to prevent unauthorized operation.

3. TECHNICAL DATA

[page 4]

Laser type	:	Solid state (Ga-As-Al)
Laser wavelength	:	780 or 830 nm (depending on probe)
Output power	:	Max. 100 mW (depending on probe) adjustable to four levels: 25, 50, 75 and 100% Continuous/pulsed
Pulse repetition frequency	:	300 Hz (50% duty cycle)
Treatment time	:	Maximum 99 minutes and 59 seconds Maximum is limited by preset dose
Dose	:	Maximum 9.99 joules (J) Maximum is limited by preset treatment time
Warning signals	:	Laser active (lamp/buzzer) Operator error (buzzer) Battery charge (lamp)
Accuracy		
Laser power	:	within 10% of power selected
Laser test light meter	:	within 10% (with powers between 5 and 100 mW)
Battery	:	12 V, 1.8 Ah maintenance-free lead accumulator (Varta Pb) Dimensions 178.5 x 34 x 60.5 mm
Laser class	:	Class 3B (according to IEC 825)
Safety class	:	II type B*
Patient leakage current	:	typically zero (IEC requirement $\leq 100 \mu\text{A}$)
Dito, single fault condition	:	typically zero (IEC requirement $\leq 500 \text{ mA}$)
Weight	:	2.8 kg
Dimensions	:	35 x 25.5 x 10 cm

Warning labels

Classification label (on top of unit)

Specification label (on top of unit and on probe)

Probes**Laser**

Wavelength	:	780 nm
Power	:	10 or 30 mW
Beam diameter	:	4 mm \pm 1 mm at 10 mm from probe
Angle of divergence	:	2.5°

Laser

Wavelength	:	830 nm
Power	:	30 or 40 mW
Beam diameter	:	4 mm \pm 1 mm at 10 mm from probe
Angle of divergence	:	2.5°

Target light

Wavelength	:	670 nm
Power	:	1 mW

Battery charger

Mains voltage	:	available for 110V, 220V or 240V, 50-60 Hz
Permissible variation	:	\pm 10%
Current consumption	:	0.065 A (220V version)
Maximum charge current	:	400 mA
Maximum charge voltage	:	14 volt
Safety class	:	II type BF*
Patient leakage current	:	Typically 5 μ A (IEC requirement < 100 μ A)
Dito, single fault	:	Typically 5 μ A (IEC requirement < 550 μ A)

- * II indicates that the charger is double insulated, has no earth (ground) connection, and therefore does not require an earthed (grounded) wall socket.
- * B indicates that the equipment meets the leakage current requirements specified in IEC 601-1.
- * BF indicates that the unit has a floating patient circuit, in which the leakage currents meet the requirements of IEC 601-1.

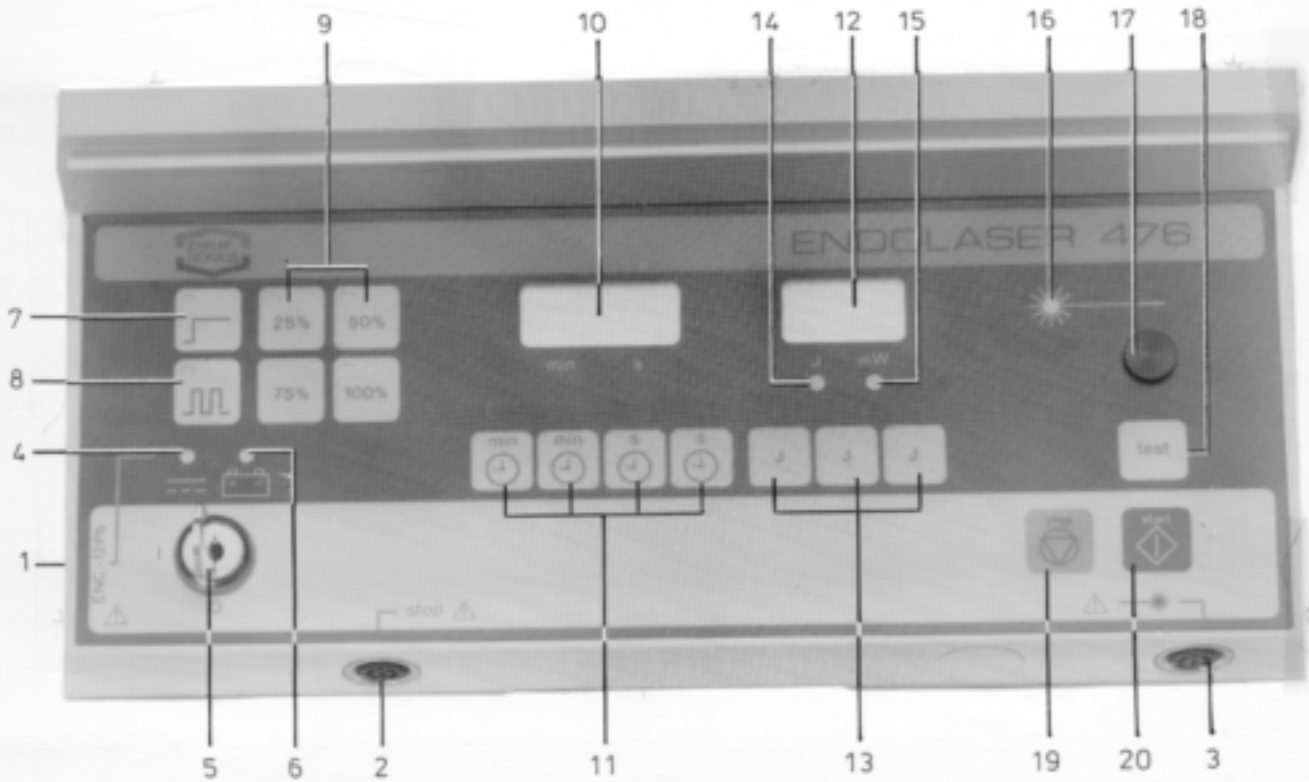

- [1] Connection for battery charger
- [2] Connection for door switch
- [3] Connection for probe

- [4] Charger indicator lamp
- [5] On/off keyswitch
- [6] Battery status lamp

- [7] Selector for continuous therapy
- [8] Selector for pulsed therapy
- [9] Selector for 25% power
- Selector for 50% power
- Selector for 75% power
- Selector for 100% power

- [10] Treatment time display
- [11] Treatment time selectors
- [12] Dose display
- [13] Dose selectors
- [14] Dose indicator lamp (J)
- [15] Power indicator lamp (mW)
- [16] Laser indicator lamp
- [17] Laser test lightmeter
- [18] Laser test selector
- [19] Stop selector
- [20] Start selector



- [21] Laser probe: laser output / target light
- [22] Laser probe: start/stop switch

DESCRIPTION OF CONTROLS

[1] Connection for battery charger

If possible, keep the battery charger connected during use, in order to conserve the battery. Connection of a battery charger other than that specified (Type ENC 12 Pb) can adversely affect the safety of the patient and the functioning of the unit, and is therefore not permitted.

[2] Connection for door switch

A door switch can be connected here (National regulations may specify particular use of a door switch or other interlock function). If the connection is left open no laser energy can be emitted.

[3] Connection for probe

This connection takes the various types of laser probe supplied by Enraf-Nonius. The dose or treatment time cannot be set if no probe is connected.

Connection of probes other than those supplied by Enraf-Nonius can adversely affect the safety of the patient and the functioning of the unit, and is therefore not permitted.

[4] Charger indicator lamp

This lamp lights when the charger is functioning correctly.

[5] On/off keyswitch

Switch on: turn key to the right (I)

Switch off: turn key to the left (O)

[6] Battery charge lamp

This lamp provides a general indication of the battery condition. There are four indications:

-continuous green light	:	battery is fully charged
-flashing green light	:	battery partly discharged
-red light	:	battery is insufficiently charged*
-lamp out	:	battery fully discharged, or unit is switched off.

* Unit switches off automatically, and treatment cannot be continued. The battery must be recharged before proceeding. See Section 5.

[7] Selector for continuous therapy

For selecting continuous laser power. A green lamp in the selector lights after pressing.

[8] Selector for pulsed laser power

For selecting pulsed laser power. A green lamp in the selector lights after pressing.

[9] Selectors for 25%, 50%, 75% and 100%

These selectors are used to set the output of the laser probe. For example, if a 10 mW probe is connected, selection of 75% will result in a power output of 7.5 mW. The output selected is indicated by a green lamp in the corresponding selector. When the unit is initially switched on, an output of 25% is selected automatically.

[10] Treatment time display

This display shows the set treatment time in minutes and seconds. The treatment time is set using the treatment selectors [11]. After treatment begins, the timer counts down to show the treatment time remaining. When the timer reaches zero, the laser is switched off automatically, and the original treatment time set reappears on the display. Treatment can now be restarted. The treatment time is automatically adapted when the output is selected or changed using the dose selectors [13], and also if the output is subsequently changed using the selectors [7], [8] or [9].

[11] Treatment time selectors

These four selectors are used to set the treatment time. The dose and dose indication are adapted automatically. The two selectors on the left are for setting the minutes (in tens and units) and the two on the right are for setting the seconds (also in tens and units). The maximum time that can be set is 99 minutes and 59 seconds.

[12] Dose display

This display shows the set dose in joules (J). The dose is set using the dose selectors [13], with a maximum possible setting of 9.99 J. The dose setting is adapted automatically when the treatment time is set or changed using the selectors [11], and when the output is changed using the selectors [7], [8] or [9]. The display flashes if the maximum dose setting is exceeded (i.e. if the treatment time is too long and the output is too high). Treatment cannot be started until an acceptable setting has been obtained by adapting the dose, output and/or treatment time.

[13] Dose selectors

These three selectors are used to set the dose in joules (J). The treatment time is automatically adapted accordingly. The selector on the left is for units, the middle selector is for tenths, and the selector on the right is for hundredths.

[14] Dose indicator lamp (J)

When this lamp is lit, the dose display shows the set dose in joules (J). This is the normal condition. However, during the laser test the lamp will go out, and the power indicator lamp [14] will light.

[15] Power indicator lamp (mW)

This lamp only lights during the laser test, i.e. when the laser test selector [18] is pressed, indicating that the dose display [12] is showing the probe power in mW.

[16] Laser indicator lamp

This lamp flashes when the laser is in operation.

[17] Laser test lightmeter

The lightmeter contains a photoelectric cell for measuring the laser output of the probe.

[18] Laser test selector

This selector activates the laser test lightmeter [17]. The output of the probe is measured, and shown on the dose display [12]. The selector must be kept pressed down during the test procedure (see next page).

[19] Stop button

This button is used to stop treatment before the treatment time has expired. All settings are then returned to zero. The stop button can also be used to cancel any settings.

[20] Start button

This button is used to start treatment. Treatment can only be started if:

- the cut-out switch is connected
- the probe is connected
- the treatment time or dose has been set.

When treatment has started and the laser is in operation, the laser indicator lamp [16] flashes, a buzzer sounds intermittently and the timer begins to count down to zero.

[21] Laser probe target light

The target area is indicated by a narrow beam of red light

[22] Laser probe start/stop contact switch

This button is used to start and to interrupt treatment.

Push once: treatment is started,

once more: treatment is interrupted.

At each interruption all settings are maintained.

LASER TEST PROCEDURE

1. Connect the door switch.
2. Connect the probe.
3. Switch on the unit.
4. Select continuous therapy and 100% power.
5. Remove the protective cover and place the probe on the laser test lightmeter [17].
6. Press the laser test selector [18] and keep it depressed.
7. Start the laser (at the probe).
8. Check the power indication on the display [12]. This must be within 20% of the power specified for the probe.

A series of horizontal lines for writing notes, organized into three columns. The first column on the left contains 20 lines. The middle column contains 20 lines. The third column on the right contains 20 lines.

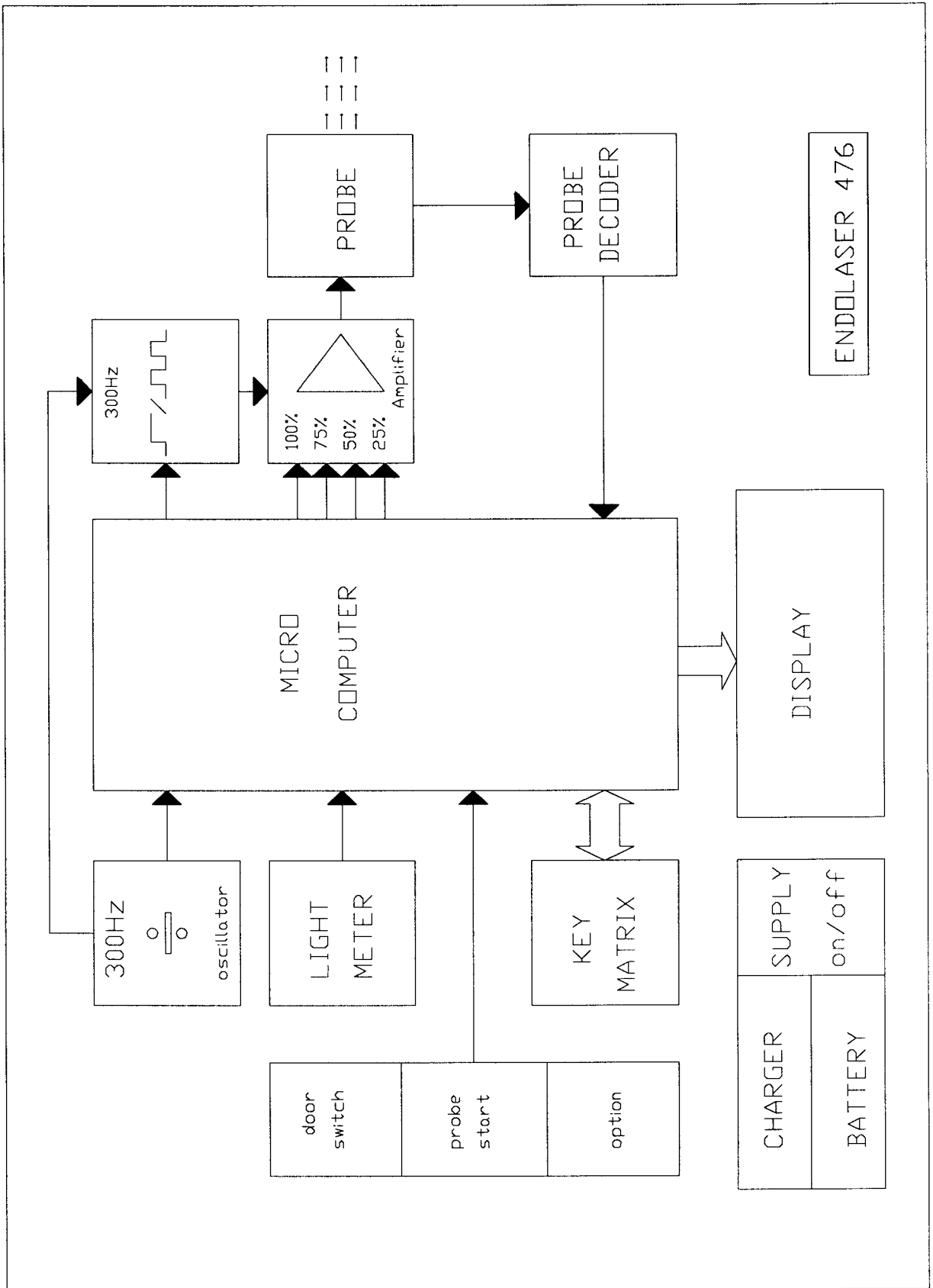

The Endolaser 476 is built up around a microprocessor system. This system controls all functions of the unit.
The processor itself contains I/O ports and 8-channel ADC converter.

Inputs for the control system:

- The door switch.
- The probe decoder signal
- The key matrix (at the front panel).
- Start/stop information (from probe).

Outputs of the control system:

- Control lines for probe power selection (25, 50, 75, 100%).
- Selection line continuous/pulsed mode.
- LED control lines.
- Display information to LCD controller.
- Sound control line.

Probe power selection

An amplifier drives the laser probe at four different levels (25, 50, 75 and 100%) and in two modes (continuous/pulsed). The output is either a continuous or a pulsed voltage.

Probe test (decoder circuit)

Different probes of different power can be connected. This circuit tests which probe is connected. (of importance for energy setting).

Power supply

The power supply includes a charger, a charger circuit (with charge current limiter), a battery and a voltage stabilizer circuit.

6.1 Sheet 1

6.1.1 **Microprocessor and Memory**

The microprocessor used is the Siemens 80535 processor. The component is equipped with 8 analog inputs (AD Converter, AN0 - AN7), and 6 times an 8-bit port. The components includes also a watchdog circuit and RAM. The unit is equipped with 2K RAM (iC2, 5516) and 16K E-prom (iC3, 27256). A cristal controlled oscillator supplies the micro-processor clock frequency. The frequency is about 11 MHz.

Function of I/O ports:

- P0 Port P0 is a multiplexed address and databus.
Address information is written to 8-bit latch (iC4), which then performs the address function for the lower address.
Data is read from the E-prom and RAM.
- P1 Port P1, for probe connections and interlock switch.
- P2 Port P2, High address (A8 - A15).
- P3 Port P3, control and communication (RD, WR, RXD, TXD).
selection normal mode - test mode (test jumper)
- P4 Port P4, LED control.
- P5 Port P5, keyboard scan.

6.2.2 **Ic19, max232**

For production only

6.2 Sheet 2

6.2.1 **Power supply, charge circuit**

The circuit is provided with protection diodes against faulty connection of the charger/battery. A 1.6AT fuse protects against short circuits. For protection of the battery, a charge current limiter circuit is made with iC10A. The non inverting input is connected to a stable 0.4 Volt. $(5/(5+27)) * 2.4 = 0.4$ Volt. The inverting input is connected to a voltage that is proportional to the charge current. The Op-Amp switches off the FET if the charge current is about 400mA.

6.2.2 Power supply, voltage regulation (does not apply for series 0)

The battery voltage varies between 9 and 13 volt. Voltage stabilization is achieved using iC50 (LM317T).

series 0

The battery voltage varies between 9 and 13 volt. Voltage stabilization is achieved using a voltage reference diode LM336 (2.5 Volt). The 2.5 Volt reference is applied to the non-inverting input of iC11D. Due to feedback the inverting input will be kept at the same level (pin 12 also at 2.5 Volt). The inverting input is connected to a voltage divider circuit (R17 and R16). The total voltage across these two resistors will be 5.0 Volt. The Op-Amp regulates the drive transistor T5. Drive transistor T5 controls the power transistors T6/T2. The transistor T4 is a current limiter. The current is limited to about 1.2 ampere. (0.6 Volt / 500 Ohm).

6.2.3 Overvoltage protection

Transistor T7 and T3, in combination with diode D6 form an overvoltage protection circuit. The circuit limits the output to a maximum of 6 Volts maximum.

Series 0

The iC11A in combination with transistor T3 and T7 form an over-voltage protection circuit. This circuit shorts the 5V power supply as soon as the voltage rises over 5.9 Volt. $[(2.4V \times (10K + 6K8)) / 6K8 = 5.9V]$. The shortening will be active until the unit has been powered off.

6.2.4 Battery check circuit

As long as the battery voltage is more than 11 volt, a green LED must light. In case the voltage is between 9 and 11 Volt the green LED should blink. If the voltage drops below 9 Volt the green LED must turn RED. All this is performed by this circuit.

The circuit uses the 2.5 Volt from the voltage reference diode as a reference for the two comparators iC11A and iC11B. The two comparators compare for 9 and 11 Volt.

In the normal condition (battery voltage more than 11 Volt)
The outputs of both comparators are low. The LED lights green.

Voltage < 11 Volt: The output of iC11B is high, via NAND iC13B the LED will blink at a frequency of 1.3 Hz.

The voltage < 9 Volt: The output of iC11A is high, This sets flip-flop iC12B, the RED LED lights. This also resets flip-flop iC12C, as a result the green LED is switched off.

Via nand iC13A the uP is resetted at powering up, and in case the voltage drops below 9 Volt. The circuit provides a power up reset active High and active Low. For testing purposes an external reset can be generated (label <reset>) without the necessity of powering-off the unit.

6.3 Sheet 3

Clock divider

The oscillation frequency (11.0592 MHz) from the cristal oscillator is divided by iC9 and iC8 to five different frequencies. The iC18A ensures the 50% dutycycle for the 300Hz laser pulsfrequency. The iC6C is used to minimize the capacitive load of the uP oscillator circuit.

6.4 Sheet 4

6.4.1 **Light measure circuit**

The light measure amplifier is constructed with straps (strap 1 - 5) to make it possible to use different light sensors and different amplifiers,

strap str1	<direct>	is not applied
strap str2	<2ampl>	is applied
strap str3	<1ampl>	is not applied
strap str4	<0V offset>	is applied
strap str5	<2.5V offset>	is not applied

Result of this choice of strap combinations is an amplification of +1x. The label <light power> can be measured at the p.c. board, labeled <Vphoto detector>. Voltages are as follows (activate light sensor with laser probe(10 / 30 / 40 mW) at test opening at the front panel):

e.g. 400mV = 40 mW
 300mV = 30 mW
 100mV = 10 mW
 10 mV ≈ 1 mW (target light only)

6.4.2 **Sound circuit**

The sound function (On/Off) is controlled by the uP port P3.5 via a connection labelled <sound disable>. The sound frequency is 1350 Hz, comming from the divider circuit. A flip flop is used to make a 50% duty cycle. The output of the flip-flop controls the piezo buzzer via a volume adjustment potentiometer.

6.4.2 **Click circuit**

The click function is controlled by the uP port P1.5 via a connection labeled <click>. Pressing the switches is normally not audible. To make it audible this click circuit is provided. The circuit contains a relay and a resettable flip-flop. As soon as a switch is pressed the line <click> will produce a pulse. After this clock pulse the flip-flop output is high. The relay is energized and its contact switches and resets the flip-flop (output low again).

6.5 Sheet 5

Keyboard

The keyboard is connected to the uP's port 5.
 The switches are connected in a 4 by 4 matrix.
 Diodes, resistors and capacitors are to protect the uP against static discharge.

6.6 Sheet 6

Display

The two displays used in the unit are of the LCD type.
 The displays are controlled by decoder/drivers iC20 - iC27. These are selected by iC7 which is a 3 to 8 decoder and functions as a multiplexer.

The 8 decoder/drivers operate in a pulsed mode (84 Hz). This is required for the functioning of the LCD. The 84 Hz is applied to the PH input and comes from the frequency divider circuit.

A power-up reset sets all displays at zero initially.

6.7 Sheet 7

6.7.1 **LED drivers**

All the LED indicators, except from those indicating the battery condition and charger connection, are controlled by the uP. The iC1 and iC2 are used as buffer.

6.7.2 **Power control circuit (25, 50, 75, 100%, continuous/pulsed)**

The outputs of iC102C,D,E,F control analog switches for selection of the output power of the laserprobe. The switches change the voltage divider circuit that drives the output buffer.

The switch related to the chosen percentage is closed.

Selection of 100% output power gives 2.0 Volt at the junction of the voltage divider (75% = 1.5V, 50% = 1V, 25% = 0.5V).

Shut down switches iC104B,D are closed in case the laser is not active. Enable switch iC1104A enables the 5 Volt supply to the power control circuit only in case the probe is active.

The iC103C is open when the unit is in the continuous mode but will be controlled by the 300 Hz when the unit is in the pulsed mode. From the diagram can be seen that in the pulsed mode there always is left some power of the chosen range (2.5, 5, 7.5 or 10% of maximum). This is achieved with resistor R129 (750 Ohm) and is to increase the laserdiode lifetime.

6.7.3 Safety

The probe control circuit is controlled both by the power up reset (active low) and by the uP. When the probe is inactive, the switches iC104A and iC104B (B) are open to ensure the analogue voltage to be low (0 Volt).

Analog switch iC104D is closed to ensure the analogue voltage to be low.

The laser active control line <laser-active> is at low logic state in order to keep the laser not active. In diagram sheet 8 a zener diode D114 is added at the analog output <analog probe drive> to limit the voltage to 2.4 Volt in case the analog switches should fail.

6.7.4 Probe connections

All the inputs and outputs to or from C-mos circuits are protected by resistors, diodes and capacitors.

The circuit around iC26D is a constant current generator at 1 mA. The 1 mA functions as a test current to determine the type of probe connected. The current is applied to a test resistor inside the probe, and the voltage across the resistor is measured <probe test> by the uP at input AN1.

The test voltages are as follows:

Voltage:	step no.	implemented/active from the uP:
<0.4	0	shorted
0.5	1	10 mW
0.7	2	20 mW
0.9	3	30 mW
1.1	4	40 mW
1.3	5	50 mW
1.5	6	60 mW
1.7	7	70 mW
1.9	8	80 mW
2.1	9	90 mW
2.3	10	100 mW
2.5	11	110 mW
2.7	12	120 mW
>2.8	13	not connected

6.7.5 The probe

No information available.

Defective probes may be returned to Enraf-Nonius for repair.

Small repairs such as probe tip replacement, cable replacement and keypad replacement are possible, see appendix A for details and part list.

8.1 General

- 8.1.1 After any repair and or maintenance, check:
- The condition of the leads of the charger,
 - Patient leakage currents, both in the normal condition as in the single fault condition according to the I.E.C. 601-1 regarding class 2, type BF equipment.
- 8.1.2 Check that the fuse has the rating specified.
- 8.1.3 Check that connectors, switches and the like are properly mounted.
- 8.1.4 Check that the test jumper is at position 2

8.2 Supply voltage

Switch on the unit and check the supply voltage:
+ 5 Volt \pm 5% at test connector

8.3 Adjustments

Adjustment of the light measure circuit.
Adjustment of the light measure circuit can be done with a well calibrated (new) probe only.

If you have a lightmeter;
Check the laser output first and calibrate to that power instead of the rated power at the label of the probe.

Perform the laser test (setting 100% and continuous laser).
If the maximum power measured is within 20% of the power mentioned at the specification label of the probe, then calibration of the meter is not required.

- Calibrate if measured power deviates more than 20%:
- R38 Adjust the potentiometer (R38) until the maximum value at the display corresponds with the power at the specification label at the probe. (or to the power measured with the external light-meter).

8.4 Test mode

In case of a fault in the power supply, Eprom, or probe drive circuit, the operation of the unit is automatically disabled.
By placing a jumper at position 1 (in diagram, position "low" at p.c. board), the unit is activated (test mode). This might be necessary for trouble shooting.

⋮ normal condition

⋮ test condition

9.0 **Initial setting**

Disconnect probe and door switch

Switch the equipment on; it performs a selftest after which the displays indicate '0' and '0'.

The unit is faulty if the display indicates ':' and '.'

(fault can be the eprom, the power supply or the probe analog voltage)

9.1 **Power supply**

Connect the charger to socket 1

LED [4] must light

Switch on the Endolaser.

The battery indicator [6] must light green.

If it starts blinking or turns red, then the battery is empty.

9.1 **Safety circuits**

Press for time setting,

a beep must sound, and time setting is not possible.

Connect the probe (check for target light)

Time setting is possible now.

Press for 1 minute time setting,

Press for start:

A beep sounds, and starting is not possible

Connect the door switch.

Press for start (point probe in safe direction)

The timer counts down, the laser is active.

Press for stop.

9.2 **Keyboard test**

Press all switches (one by one) and check for the click sound.

9.3 **Probe test**

Select for 100%, continuous laser

Remove the cover from the test opening.

Hold the probe perpendicular at this opening.

Press at test and press the start button at the probe.

The display should read the rated (at probe) value $\pm 20\%$.

We advise to subject the Endolaser 476 to regular inspectios, e.g. once a year, to guarantee the safety and the functioning of the apparatus as specified. Please carry out the following:

- 1 Modifications, if any, will be published by means of technical info sheets (T.I.'s).
- 2 Checks;
Check the condition of the leads of the charger nearby the plug
Check the connection to the probe plug.
- 3 Carry out the function test as described on previous page.
- 4 Carry out an electrical safety test
- 6 Keep a file of all service activities with the equipment. See sample of a service file on next page.

Tools required / tools advised*)

- oscilloscoop
- frequency counter
- multimeter
- safety tester
- light multimeter*)

- *) Chopped light multimeter.
model 33XLC, Photodyne Inc.
adaper/filter model 350 (1 Watt, 700 - 1100 nm)

S1 (Key switch)

black wire	from CN2-1	key switch pin 1
white wire	from CN2-2	key switch pin 3

Socket 1 (charger plug)

black wire	from CN3-1	to charger plug (-)
red wire	from CN3-2	to charger plug (+)

Socket 2 (doorswitch)

white wire	from CN6-1	to socket	pin 3	gnd
red	from CN6-2		pin 2	doorswitch
black	from CN6-3		pin 5	start
brown	from CN6-4		pin 1	laser act.
blue	from CN6-5		pin 7	scan
orange	from CN6-6		pin 4	+5V

Socket 3 (probe connections)

black wire	from CN5-1	to socket	pin 7	gnd
brown	from CN5-2		pin 1	test
red	from CN5-3		pin 8	out
orange	from CN5-4		pin 6	las. on
blue	from CN5-5		pin 2	start
violet	from CN5-6		pin 3	gnd
grey	from CN5-7		pin 5	+5V
white	from CN5-8		pin 4	+5V
	CN5-9			gnd
	CN5-10			nc

Battery

blue	from CN4-1	to battery (-)
red	from CN4-2	to battery (+)

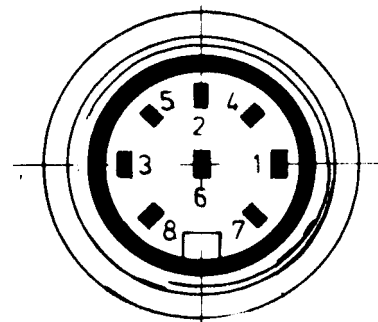

soldering side

HOUSING, sectional drawing

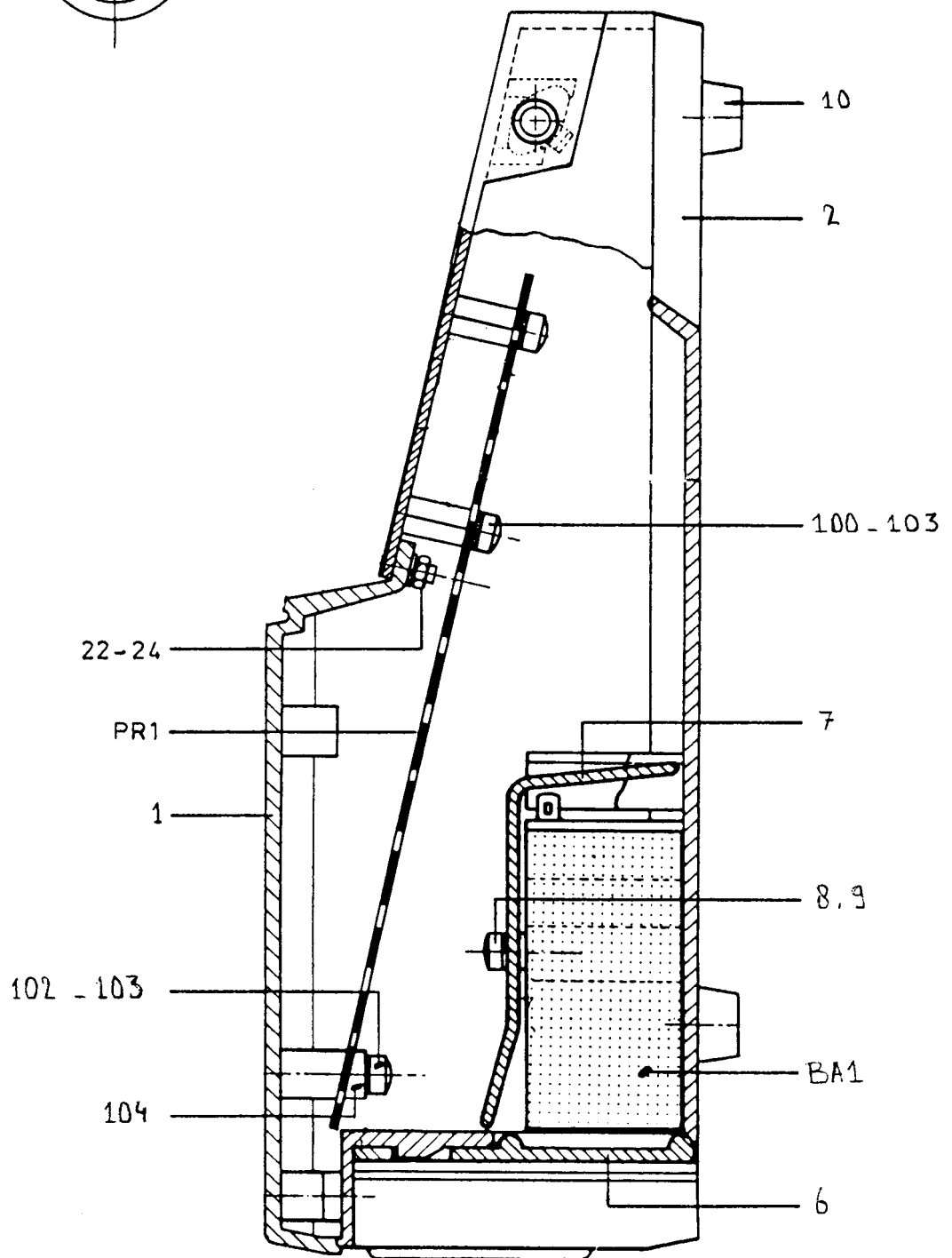
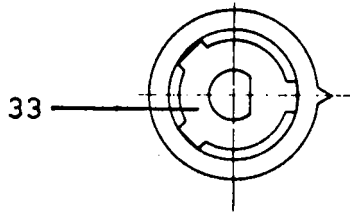



ACCESSORIES

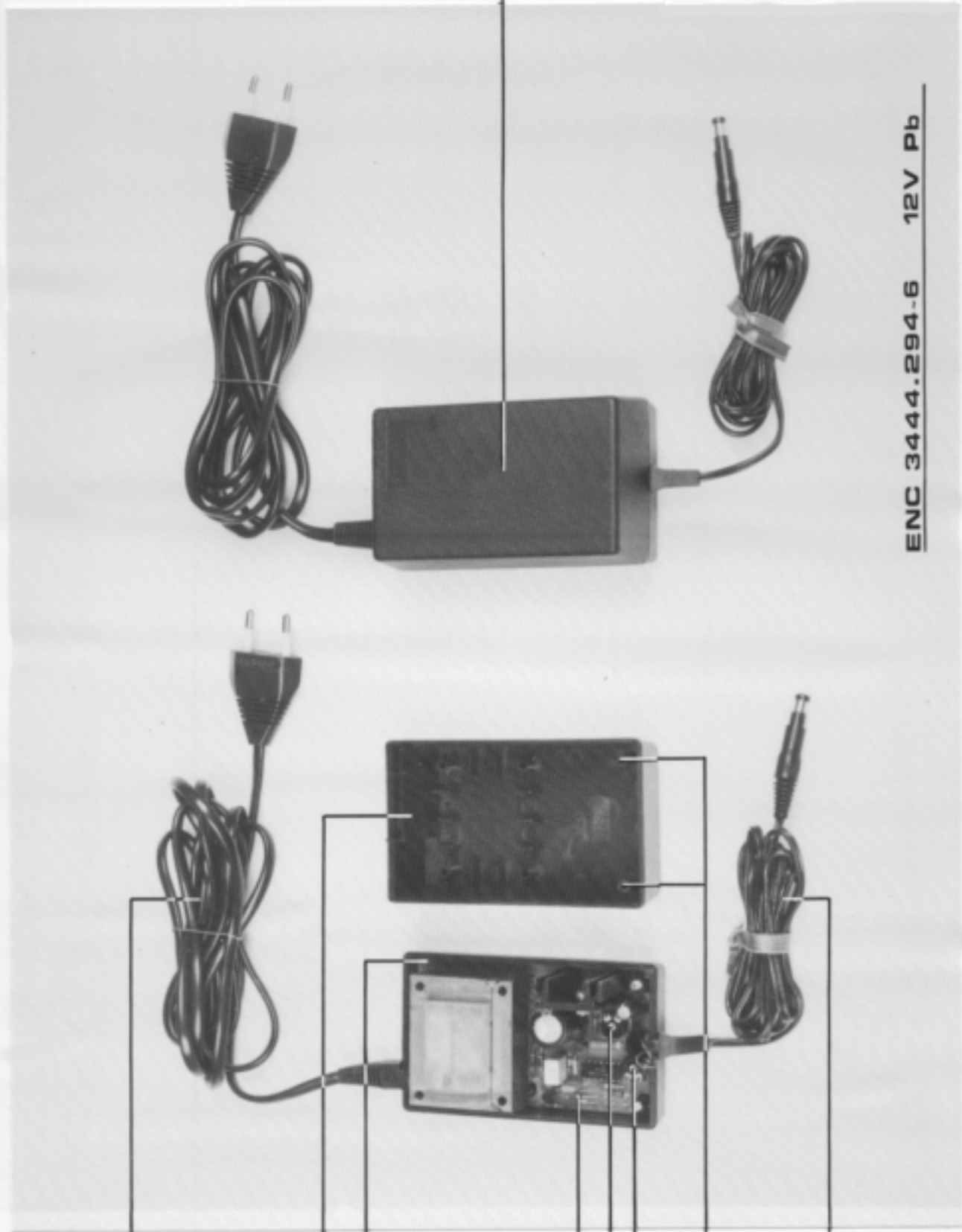

805

802

803

801

P2

P1

804

806

800

ENC 3444.294-6 12V Pb

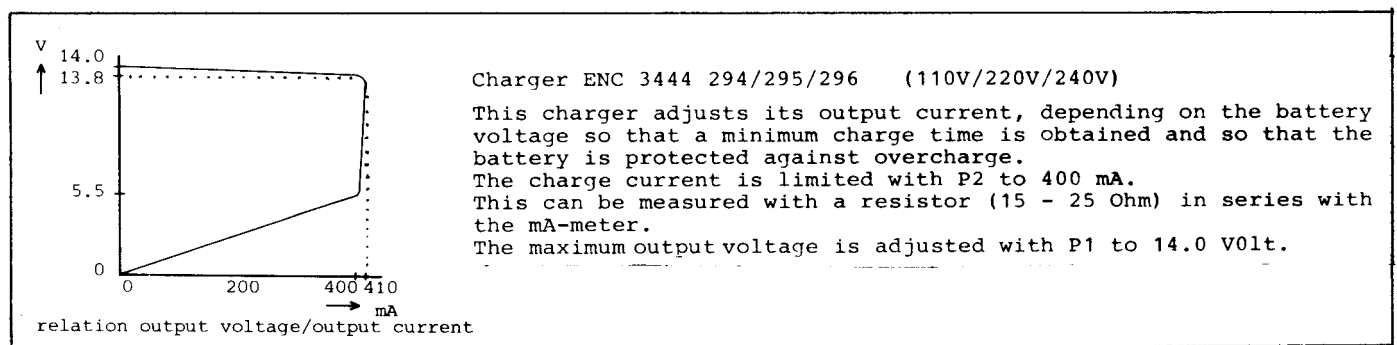
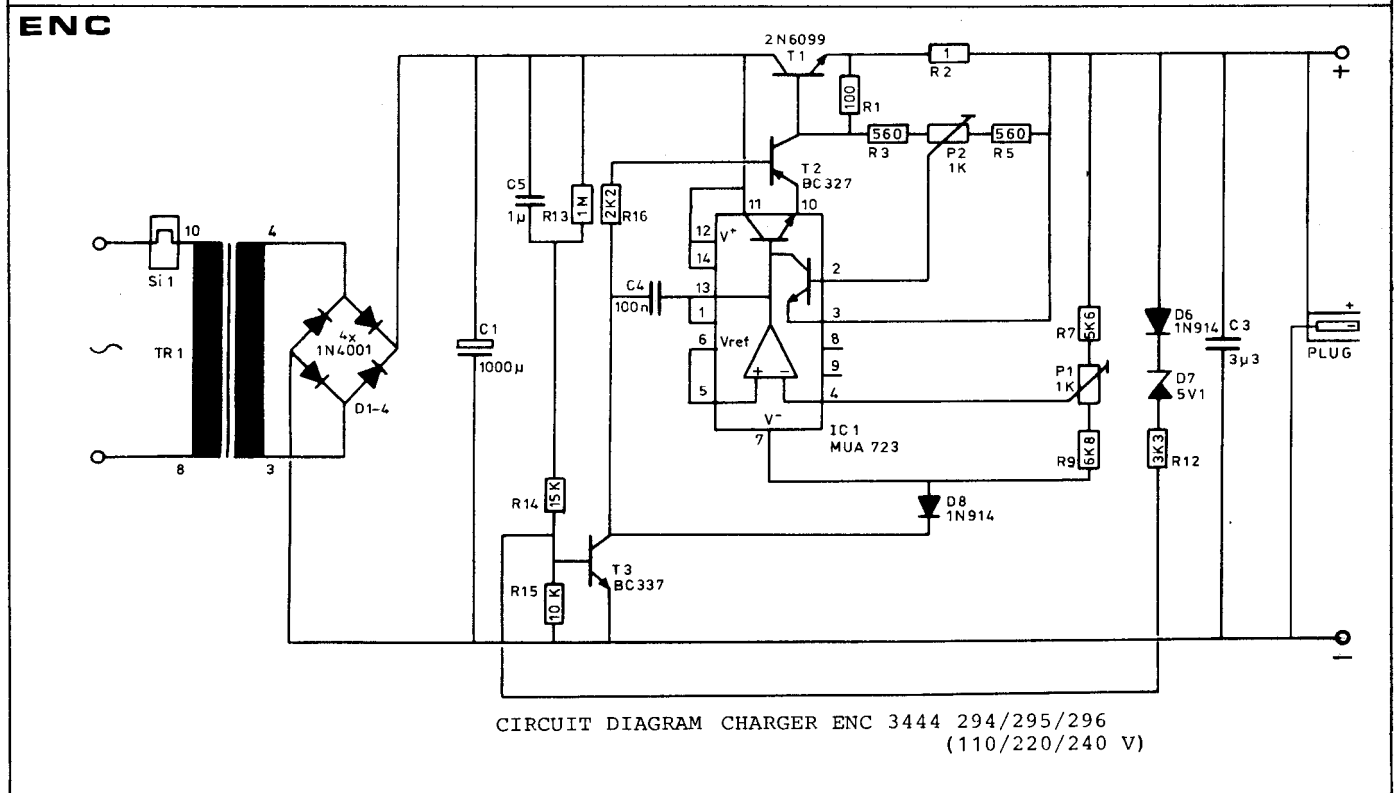
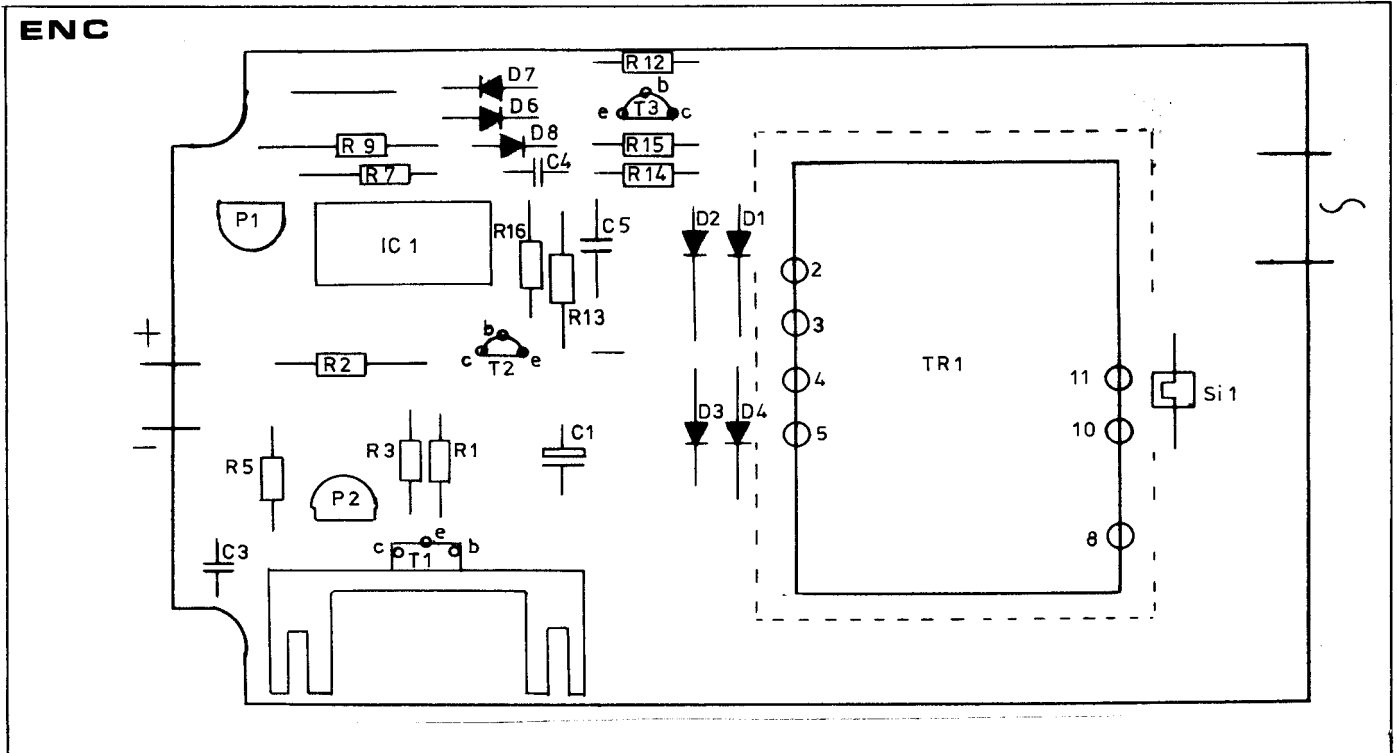

PARTS LIST ENDOLASER 476

06/02/90

Item	Description	ref. no.	Remarks
	ENDOLASER 476, including accessories	1476.901	220V - 50/60 Hz
	ENDOLASER 476, including accessories	1476.902	110V - 50/60 Hz
	ENDOLASER 476, including accessories	1476.906	240V - 50/60 Hz
	Probe 780nm/10mW	3444.816	
	Probe 830nm/30mW	3444.817	
	Probe 780nm/30mW	3444.818	
*adapter/charger,	ENC 3444.294 12V-Pb	3444.294	220V - 50/60z
*adapter/charger,	ENC 3444.295 12V-Pb	3444.295	110V - 50/60z
*adapter/charger,	ENC 3444.296 12V-Pb	3444.296	240V - 50/60z
HOUSING			
1	Upper part	2994.137	
2	base part	2994.144	
3	Screw, cross slotted (4x)	6006.027	m4x16
4	Screw, cross slotted (2x)	6006.025	m4x10
5	Washer (6x)	6083.104	m4
6	Battery compartment lid	2994.076	
7	Battery cover	2994.075	
8	Screw, cross slotted (2x)	6006.027	m4x16
9	Washer spring (2x)	6083.104	m4
10	Support (4x)	2032.053	
BA1	Battery	2501.016	Pb, 12V, 1.8 Ah
20*	Front panel Indication plate with supporting plate (not including the key switch)	0476.801	including 25 and 26
22	Nut (6x)	6064.004	m4
23	Washer, spring (6x)	6083.104	m4
24	Washer, flat (6x)	6076.504	m4
25	Light sensor socket	2994.708	
26*	Light sensor cap	2994.708	
socket1*	Input adapter/charger	2524.740	
socket2*	Connection door-switch	2523.945	
socket3*	Connection probe	2523.945	
item1*	Key switch	2601.377	

* spare part

Item	Description	ref. no.	Remarks
	P.C. BOARD 1		
PR1*	Printed circuit board complete	0476.810	
100	Screw (5x)	2146.603	m4x8
101	Distance holder (5x)	2291.639	L = 13 mm
102	Screw (3x)	6006.027	m4x16
103	Washer, spring (3x)	6083.104	m4
C1	Capacitor	-	100nF
C2	Capacitor	-	22pF
C3	Capacitor	-	27pF
C4	Capacitor	-	100nF
C5	Capacitor	-	100nF
C6	Capacitor	-	100nF
C7	Capacitor	-	100nF
C8	Capacitor	-	100nF
C9	Capacitor	-	100nF
C10	Capacitor	-	100nF
C11	Capacitor	-	100nF
C12	Capacitor	-	100nF
C13	Capacitor	-	100nF
C14	Capacitor	-	100nF
C15	Capacitor	-	100nF
C16	Capacitor	-	100nF
C17	Capacitor	-	100nF
C18	Capacitor	-	100nF
C19	Capacitor	-	100nF
C20	Capacitor	-	10nF
C21	Capacitor	-	10nF
C22	Capacitor	-	100nF
C23	Capacitor	-	100nF
C24	Capacitor	-	1uF
C25	Capacitor	-	4u7
C26	Capacitor	-	10u
C27	Capacitor	-	4u7
C28	Capacitor	-	10u
C29	Capacitor	-	100nF
C30	Capacitor	-	100nF
C31	Capacitor	-	4u7
C32	Capacitor	-	100nF
C33	Capacitor	-	27pF
C34	Capacitor	-	100nF
C35	Capacitor	-	100nF
C36	Capacitor	-	100nF
C37	Capacitor	-	100nF
C38	Capacitor	-	470nF
C41	Capacitor	-	10uF
C41	Capacitor (series 0)	-	1n0
C42	Capacitor	-	10uF
C42	Capacitor (series 0)	-	10nF
C43	Capacitor	-	10nF
C44	Capacitor	-	1uF
C45	Capacitor	-	100nF

* Spare part

Item	Description	ref. no.	Remarks
C51	Capacitor	-	10nF
C70	Capacitor	-	10nF
C71	Capacitor	-	10nF
C72	Capacitor	-	10nF
C73	Capacitor	-	10nF
C74	Capacitor	-	10nF
C75	Capacitor	-	10nF
C76	Capacitor	-	10nF
C77	Capacitor	-	10nF
C101	Capacitor	-	10nF
C102	Capacitor	-	10nF
C103	Capacitor	-	10nF
C104	Capacitor	-	2n2
C105	Capacitor	-	100nF
C106	Capacitor	-	22pF
C110	Capacitor	-	10nF
C111	Capacitor	-	10nF
C112	Capacitor	-	100nF
D1 *	Diode	2562.126	SB340
D2	Diode	2562.126	SB340
D3 *	Diode	2563.095	1N4148 (1N914)
D4 *	Diode, zener	3492.958	BZX 2V4
D5	Diode	on demand	1N4004
*	Diode, series 0 only	2562.245	LM336
D6 *	Diode, zener	2563.221	5V6
	Diode, series 0 only	3492.958	BZX 2V4
D7	Diode	on demand	1N4004
D7	Diode	2563.095	1N4148 (1N914)
D8	Diode	2563.095	1N4148 (1N914)
D9	Diode	2563.095	1N4148 (1N914)
D10	Diode	2563.095	1N4148 (1N914)
D11	Diode	2563.095	1N4148 (1N914)
D50	LED, yellow	on demand	
D51	LED, green	on demand	TLUG 5400
D52	LED, green	on demand	TLUG 5400
D53	LED, green	on demand	TLUG 5400
D54	LED, green	on demand	TLUG 5400
D55	LED, green	on demand	TLUG 5400
D56	LED, green	on demand	TLUG 5400
D57	LED, green	on demand	TLUG 5400
D58	LED, green	on demand	TLUG 5400
D59	LED, red/green	on demand	TLUV 5400
D70	Diode	2563.095	1N4148 (1N914)
D71	Diode	2563.095	1N4148 (1N914)
D73	Diode	2563.095	1N4148 (1N914)
D74	Diode	2563.095	1N4148 (1N914)
D75	Diode	2563.095	1N4148 (1N914)
D76	Diode	2563.095	1N4148 (1N914)
D77	Diode	2563.095	1N4148 (1N914)
D78	Diode	2563.095	1N4148 (1N914)

* Spare part

Item	Description	ref. no.	Remarks
D80	Diode	2563.095	1N4148 (1N914)
D81	Diode	2563.095	1N4148 (1N914)
D82	Diode	2563.095	1N4148 (1N914)
D83	Diode	2563.095	1N4148 (1N914)
D84	Diode	2563.095	1N4148 (1N914)
D85	Diode	2563.095	1N4148 (1N914)
D101	Diode	2563.095	1N4148 (1N914)
D102	Diode	2563.095	1N4148 (1N914)
D103	Diode	2563.095	1N4148 (1N914)
D104	Diode	2563.095	1N4148 (1N914)
D105	Diode	2563.095	1N4148 (1N914)
D106	Diode	2563.095	1N4148 (1N914)
D110	Diode	2563.095	1N4148 (1N914)
D111	Diode	2563.095	1N4148 (1N914)
D112	Diode	2563.095	1N4148 (1N914)
D112	Diode	2563.095	1N4148 (1N914)
D114	Diode	3492.958	BZX 2V4
Dfoto*	Diode	on demand	VTS2082
iC1*	Integrated circuit (uP)	3492.950	80535
iC2*	Integrated circuit (2k SRAM)	3452.951	5516 or 5817
iC3*	Integrated circuit (e-prom)	3492.952	e-prom, programmed
iC4*	Integrated circuit	3492.953	74HCT573
iC5*	Integrated circuit	2517.014	74HCT14
iC6*	Integrated circuit	2517.008	74HCT08
iC7*	Integrated circuit	3492.954	74HCT238
iC8*	Integrated circuit	2514.020	4020
iC9*	Integrated circuit	3492.955	74HC4020
iC10*	Integrated circuit	2519.319	LM324
iC11	Integrated circuit	2519.319	LM324
iC12*	Integrated circuit	2514.013	4013
iC13*	Integrated circuit	2514.093	4093
iC14	Integrated circuit	2514.013	4013
iC15	Integrated circuit	2519.319	LM324
iC16*	Integrated circuit	2514.081	4081
iC17	Integrated circuit	2514.020	4020
iC18	Integrated circuit	2514.013	4013
iC20*	Integrated circuit	3492.956	74HCT4543
iC21	Integrated circuit	3492.956	74HCT4543
iC22	Integrated circuit	3492.956	74HCT4543
iC23	Integrated circuit	3492.956	74HCT4543
iC24	Integrated circuit	3492.956	74HCT4543
iC25	Integrated circuit	3492.956	74HCT4543
iC26	Integrated circuit	2519.319	LM324
iC27	Integrated circuit	3492.956	74HCT4543
iC28	Integrated circuit	3492.956	74HCT4543
iC50	Integrated circuit/voltage regulator	on demand	LM317T
iC101*	Integrated circuit	2517.014	74HCT14
iC102	Integrated circuit	2517.014	74HCT14
iC103*	Integrated circuit	3492.957	HCT4066
iC104	Integrated circuit	3492.957	HCT4066
iC105	Integrated circuit	2517.008	74HCT08

* **Spare part**

Item	Description	ref. no.	Remarks
IN1	Coil	-	13uH
IN2	Coil	-	13uH
Pz1*	Buzzer (piezo)	on demand	AT20
R1	Resistor	-	3E3
R2	Resistor	-	3E3
R3	Resistor	-	3E3
R5	Resistor	-	5K1
R6	Resistor	-	27K
R7	Resistor	-	1K0
R8	Resistor	-	2K2
R9	Resistor	-	1K5
	Resistor (series 0 only)	-	1E5
R10	Resistor	-	360E
	Resistor (series 0 only)	-	1E5
R11	Resistor (series 0 only)	-	1E5
R12	Resistor (series 0 only)	-	1E5
R13	Resistor (series 0 only)	-	n.a.
R14	Resistor (series 0 only)	-	1K0
R15	Resistor (series 0 only)	-	1K0
R16	Resistor (series 0 only)	-	39K
R17	Resistor (series 0 only)	-	391K
R18	Resistor (series 0 only)	-	10K
R19	Resistor (series 0 only)	-	1K0
R20	Resistor (series 0 only)	-	6K8
R21	Resistor (series 0 only)	-	680E
R22	Resistor (series 0 only)	-	10K
R23	Resistor (series 0 only)	-	8K2
R24	Resistor	-	10K
R25	Resistor	-	10K
R26	Resistor	-	33K
R27	Resistor	-	2K2
R28	Resistor	-	10K
R29	Resistor	-	1M0
R30	Resistor	-	470E
R31	Resistor	-	470E
R32	Resistor (series 0 only)	-	1K0
R33	Resistor (series 0 only)	-	10K
R34	Resistor	-	820K
R35	Resistor	-	1K0
R36	Resistor	-	1K0
R37	Resistor	-	1K0
R38	Resistor	-	100E
R39	Resistor	-	100K
R40	Resistor	-	100K
R41	Resistor	-	100K
R42	Resistor	-	100K
R43	Resistor	-	1K0
R44	Resistor	-	100K
R45	Resistor	-	100K
R46	Resistor	-	100K
R47	Resistor	-	100K
R48	Resistor	-	10K
R49	Resistor	-	470E

* Spare part

Item	Description	ref. no.	Remarks
R50	Resistor	-	470E
R51	Resistor	-	470E
R52	Resistor	-	470E
R53	Resistor	-	470E
R54	Resistor	-	470E
R55	Resistor	-	470E
R56	Resistor	-	470E
R57	Resistor	-	100K
R58	Resistor	-	1K0
R59	Resistor	-	10K
R60	Resistor	-	10K
R61	Resistor	-	10K
R62	Resistor	-	10K
R63	Resistor	-	10K
R64	Resistor	-	1K2
R65	Resistor	-	390E
R66	Resistor	-	1K0
R67	Resistor	-	10K
R68	Resistor	-	100K
R69	Resistor	-	47E
R70	Resistor	-	180E
R71	Resistor	-	180E
R72	Resistor	-	180E
R73	Resistor	-	180E
R74	Resistor	-	180E
R75	Resistor	-	180E
R76	Resistor	-	180E
R77	Resistor	-	180E
R78	Resistor	-	10K
R79	Resistor	-	10K
R80	Resistor	-	10E
R101	Resistor	-	10K
R102	Resistor	-	10K
R103	Resistor	-	1K0
R104	Resistor	-	10K
R105	Resistor	-	100K
R106	Resistor	-	100K
R107	Resistor	-	100K
R110	Resistor	-	10K
R112	Resistor	-	10K
R113	Resistor	-	1K0
R114	Resistor	-	1K0
R115	Resistor	-	1K0
R116	Resistor	-	10K
R117	Resistor	-	10K
R118	Resistor	-	10K
R119	Resistor	-	20K
R120	Resistor	-	47K
R121	Resistor	-	30K0
R123	Resistor	-	471K0

* Spare part

Item	Description	ref. no.	Remarks
R125	Resistor	-	100K
R126	Resistor	-	390K
R127	Resistor	-	180K
R129	Resistor	-	750E
R130	Resistor	-	120K
R131	Resistor	-	200K
T1 *	Transistor dito dito	on demand 2562.619 2562.620	MTP3055 BUZ71A (alternative) BUZ72A (alternative)
T3	Transistor dito	on demand 2562.443	BDT94 BD242 (alternative)
T2 *	Transistor dito	on demand 2562.443	BDT94 BD242 (alternative)
T4 *	Transistor dito	on demand 2562.444	BC558 BC327 (alternative)
T5 *	Transistor	2563.359	BC547
T6	Transistor dito	on demand 2562.444	BC558 BC327 (alternative)
T7	Transistor	2563.359	BC547
T8	Transistor	2563.359	BC547
T9	Transistor	2563.359	BC547
T10	Transistor	2563.359	BC547
T101	Transistor dito	on demand 2562.444	BC558 BC327 (alternative)
*	Spare part		

HOW TO ORDER SPARE PARTS

If you want to order spare parts (marked * in the list), please mention the reference number, description, (item number) and number of components wanted.

e.g.

0476.810, pc.board complete 1X for Endolaser 476, series 2

For availability of components, please see the 'spare parts price list'.

item	description	ref. no.	electrical data	remarks
------	-------------	----------	-----------------	---------

BATTERY CHARGER ENC 12-Pb (LG701)

Components are drawn in the diagram and the lay-out without the prefix "800"
e.g. R8003 is drawn as R3

800	* Battery charger, complete	3444.294	110V, 50 - 60Hz (USA)	
		3444.295	220V, 50 - 60Hz (IEC)	
		3444.296	240V, 50 - 60Hz (UK)	
801	P.C. Board	on demand		
802	Housing, upper part	on demand		
803	Housing, bottom part	on demand		
804	Screws (3x)	on demand		
805	* Mains cable, with USA - plug	on demand		
	with IEC - plug	2570.116		
	with UK - plug	on demand		
806	* Charging lead with plug	2570.115		

-P.C. Board-

C8001	Capacitor	on demand	1000uF	
C8003	Capacitor	on demand	3u3	
C8004	Capacitor	on demand	100nF	
C8005	Capacitor	on demand	1uF	
D8001	Diode	on demand	1N4001	
D8002	Diode	on demand	1N4001	
D8003	Diode	on demand	1N4001	
D8004	Diode	on demand	1N4001	
D8006	Diode	2563.095	1N914	
D8007	Diode, zener 5.1V	2563.254	ZPD5.1	
D8008	Diode	2563.095	1N914	
IC8001	Integrated Circuit	2518.009	UA723	
P8001	Potentiometer, trimmer	on demand	1k	0.1W
P8002	Potentiometer, trimmer	on demand	1k	0.1W
R8001	Resistor	2713.193	100E	1/4W 5%
R8002	Resistor	2701.001	1E	1W 1%
R8003	Resistor	2803.560	560E	1/4W 1%
R8005	Resistor	2803.560	560E	1/4W 1%
R8007	Resistor	2713.361	5k6	1/4W 5%
R8009	Resistor	2713.369	6k8	1/4W 5%
R8012	Resistor	2713.337	3k3	1/4W 5%
R8013	Resistor	2713.577	1M	1/4W 5%
R8014	Resistor	2805.150	15k	1/4W 1%
R8015	Resistor	2713.385	10k	1/4W 5%
R8016	Resistor	2804.221	2k2	1/4W 1%
T8001	Transistor	on demand	2N6099	
T8002	Transistor	2562.444	BC327	
T8003	Transistor	2562.533	BC337	
TR8001	Transformer	on demand		

* We advise to keep marked items in stock

ENDOLASER 476 PROBES SPECIAL SERVICING

Table of Contents

- 1. Introduction**
- 2. Safety**
- 3. Handling precautions**
- 4. Other precautions**
- 5. Probe Tip replacement**
- 6. Cable replacement**
- 7. Keypad replacement**

ENDOLASER 476 PROBES SPECIAL SERVICING

INTRODUCTION

The purpose of this guide is to enable Delft Instruments Physical Medicine and authorized service personnel to carry out smaller repairs on Endolaser 476 probes.

SAFETY

WARNING! ALWAYS USE PROTECTIVE EYEWEAR WHEN OPERATING THE LASER!

Irradiation from the laser diodes may cause severe damage to the human eye. When the laser probe is being operated, NEVER stare into the beam or view directly with optical instruments.

When checking the optical axis of the laser beam, it is recommended that an IR scope or a fluorescent screen that converts infrared light to visible light be used.

ALWAYS USE suitable protective eyewear, which gives sufficient protection against 830nm infrared radiation.

SELECTING PROTECTIVE EYEWEAR FOR ENDOLASER 476 LASER PROBES:

1. Resistant against the specific irradiance?
2. Acceptable daylight transmittance?
3. Required Optical Density (OD):
 - OD0: 0.69mW
 - OD1: 6.9mW
 - OD2: 69mW
 - OD3: 690mW

(The radiant powers stated are based on IEC825 calculations)

The Bollé glasses previously supplied with the Endolaser are resistant against the irradiance of the probes, have an Optical Density of 2 and give sufficient protection up to a radiant power of 69mW. Protective eyewear with higher OD and better daylight transmittance can be supplied.

HANDLING PRECAUTIONS

Caution

Laser diodes are very sensitive to electrostatic discharge. The sensitivity for electrostatic discharge is even greater than CMOS LSI's.

The following handling precautions must be strictly obeyed.

All workbenches, equipment and human operators must be properly grounded when handling the CLB. Even a momentary surge of static electricity will instantaneously destroy the laser diodes.

Dust, fingerprints, and other material on the lenses will degrade the laser beam's quality due to interference, diffraction and absorption.

Standard precautions to be taken when working with the CLB:

1. Ground all objects (workbench, soldering iron, electrical equipment)
2. Ground human operator. (Wear grounded wrist-strap. Use of anti-static shoes is advisable but not essential.)
3. Wear finger sacks to avoid fingerprints on the lenses, if the CLB is touched.
4. Do not use air nippers, since they generate static electricity.
5. Keep temperature of soldering iron below 320 deg.C, and soldering time short.

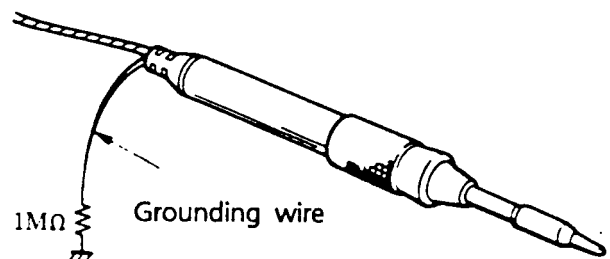
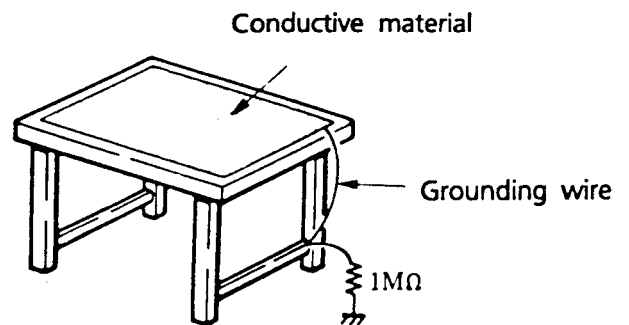
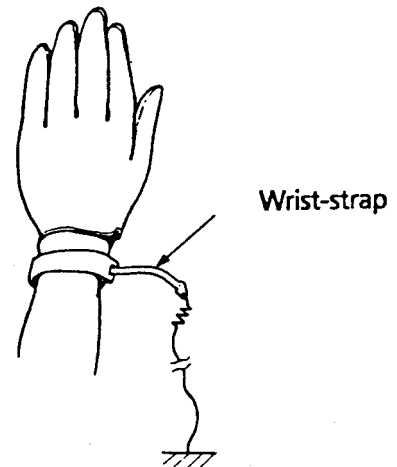

OTHER PRECAUTIONS

DUST ON LENSES

Note that deposits or dust on the lenses mounted in the Collimating Laser Block (CLB) can cause deterioration of the characteristics of the laser diodes.

1. Do not touch the lenses with bare hands.
2. Take care and avoid damaging the lenses with tools.
3. When dust deposited on the lenses is to be removed with an air gun, short-circuit the leads or use a moss pack covered with a conductive bag.

TOXICITY OF ARSENIC

The chip of the laser diodes is mainly composed of GaAs which contains about 50% of arsenic, well known as a toxic substance.

The toxicity of a compound semiconductor like GaAs in itself is by far weaker than that of the other arsenic compounds such as As_2O_3 (arsenic acid), $AsCl_3$ (arsenic trichloride), etc. The content of arsenic per chip is as small as 30ug and therefore does not present any serious problem. However it should be ensured that the chips of the laser diodes are never removed and put in an acid or alkali solution, heated to more than 200deg.C or put in the mouth.

PROBE TIP REPLACEMENT

WORKING ENVIRONMENT

All service must take place under grounded/anti-static working conditions (refer to "Handling precautions").

TOOL LIST

Screwdriver, Size PT1
Probe grounding cable (see spare parts list)

REQUIRED SPARE PARTS

Probe Tip with coated window (see spare parts list)

SERVICE PROCEDURE

1. Connect the probe's DIN plug to the grounding cable and ensure that the grounding cable is connected to the working environment.
2. Carefully remove the Enraf serial number label from the probe and remove the screw in the probe cabinet.
Hold the probe up-side-down and separate the two probe cabinet parts.
CAUTION! DO NOT TOUCH THE PC BOARD OR THE ALUMINIUM COLLIMATING LASER BLOCK (CLB).
3. Remove the old probe tip.
4. Inspect the new probe tip for dust etc. and clean if necessary with cleaning solution (see spare parts list).
5. Insert the new probe tip.
6. Reassemble the cabinet.
CAUTION! Ensure that no wires are jammed in the cabinet!
Remount the screw in the cabinet.
CAUTION! Tighten the screw carefully - it is screwed into ABS plastic!
7. Test the probe output power on an Endolaser 476 at 100% output setting.
8. Place the Enraf serial number label back and fill in an service report.

AM GROUNDING CABLE

Not used

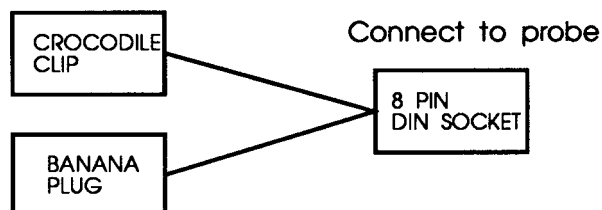

Connect to grounded working environment

SERIAL NUMBER LABELS

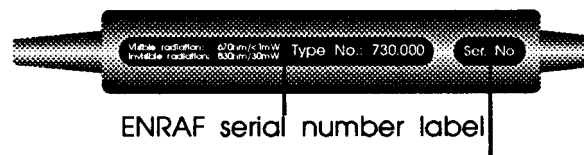

AM serial number
DO NOT REMOVE

CABINET SEPARATION

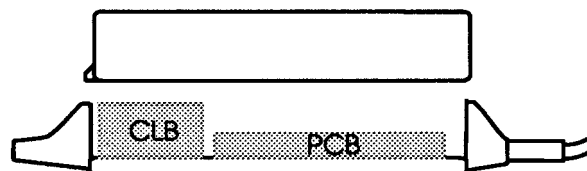

CABLE REPLACEMENT

WORKING ENVIRONMENT

All service must take place under grounded/anti-static working conditions (refer to "Handling precautions").

TOOL LIST

Screwdriver, Size PT1
Probe grounding cable (see spare parts list)

REQUIRED SPARE PARTS

Probe cable with DIN plug and connector (see spare parts list)

SERVICE PROCEDURE

1. Connect the probe's DIN plug to the grounding cable and ensure that the grounding cable is connected to the working environment.
2. Carefully remove the Enraf serial number label from the probe and remove the screw in the probe cabinet. Hold the probe up-side-down and separate the two probe cabinet parts.
CAUTION! DO NOT TOUCH THE PC BOARD OR THE ALUMINIUM COLLIMATING LASER BLOCK (CLB).
3. Connect the crocodile clip on the grounding cable to the CLB.
4. Unscrew the cable reliefment. Disconnect and remove the old cable.
5. Disconnect the old cable from the grounding cable and connect the new cable to the grounding cable.
6. Insert and connect the new cable to the pc board. Remount and tighten the cable reliefment.
7. Remove the crocodile clip from the CLB and reassemble the cabinet.
CAUTION! Ensure that no wires are jammed in the cabinet!
Remount the screw in the cabinet.
CAUTION! Tighten the screw carefully - it is screwed into ABS plastic!
8. Test the probe output power on an Endolaser 476 at 100% output setting.
9. Place the Enraf serial number label back and fill in a service report.

AM GROUNDING CABLE

Not used

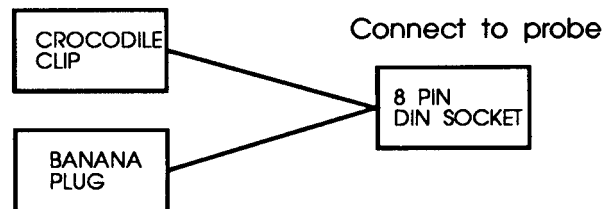

Connect to grounded working environment

SERIAL NUMBER LABELS



ENRAF serial number label

AM serial number
DO NOT REMOVE

CABINET SEPARATION

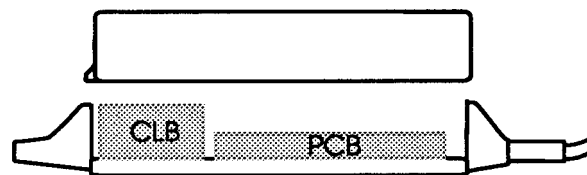

CROCODILE CLIP CONNECTION

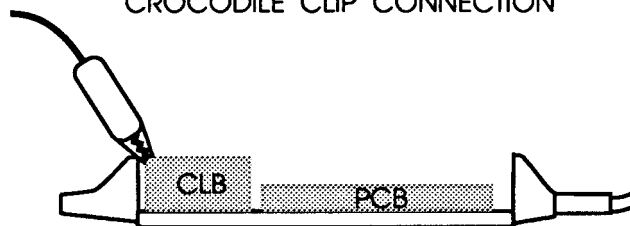

KEYPAD REPLACEMENT

WORKING ENVIRONMENT

All service must take place under grounded/anti-static working conditions (refer to "Handling precautions").

TOOL LIST

Screwdriver, Size PT1
 Screwdriver, Size PZ1
 Probe grounding cable (see spare parts list)
 Sealing (Dow Corning 3140)

REQUIRED SPARE PARTS

Probe cabinet top with mounted keypad and type label (10mW, 30mW or 70mW) (see spare parts list)

SERVICE PROCEDURE

1. Connect the probe's DIN plug to the grounding cable and ensure that the grounding cable is connected to the working environment.
2. Carefully remove the Enraf serial number label on the probe and remove the screw in the probe cabinet. Hold the probe up-side-down and separate the two probe cabinet parts. **CAUTION! DO NOT TOUCH THE PC BOARD OR THE ALUMINIUM COLLIMATING LASER BLOCK (CLB).**
3. Connect the crocodile clip on the grounding cable to the CLB.
4. Use screwdriver PT1 to remove the sealing on the two 6 pin connectors which connect the two pc boards to each other. **CAUTION! Be careful not to damage any components.**
5. Unscrew the cable reliefment and disconnect the 2 pin keypad connector.
6. Unscrew the four screws in the CLB. Remove the CLB and top pc board together. **CAUTION! The CLB and the pc board MUST NOT be disconnected/separated!**
7. Unscrew the two screws in the bottom pc board and remove the pc board together with the cable.
8. Remount the pc board and cable in the new probe cabinet top (see spare parts list).

AM GROUNDING CABLE

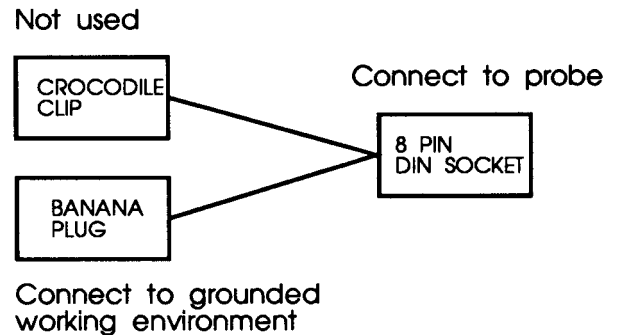

SERIAL NUMBER LABELS

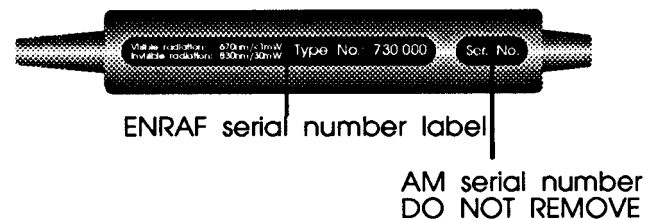

CABINET SEPARATION

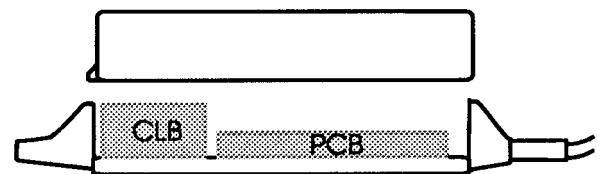

CROCODILE CLIP CONNECTION

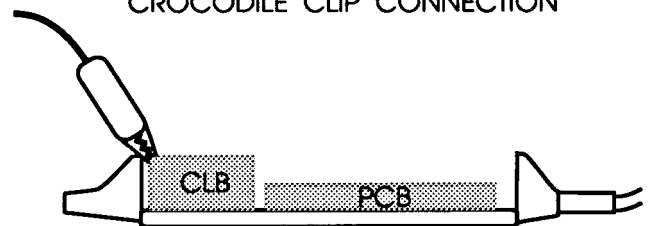

CONTINUED.....

17.09.1992 MdB

KEYPAD REPLACEMENT

CONTINUED

9.
Remount the CLB and connect the PC BOARD with the four screws.
CAUTION! Ensure that the legs of the NTC resistor (placed between the PC BOARD and the CLB) do NOT touch the CLB.
10.
Remount and tighten the cable reliefment.
CAUTION! Tighten the screws carefully - they are screwed into ABS plastic!
11.
Connect the 2 pin keypad connector to the pc board.
12.
Glue the two 6 pin connections with Dow Corning 3140 sealing component.
13.
Check that all connectors/connections are properly in place - particularly the connection between the PC BOARD and the CLB.
14.
Remove the crocodile clip from the CLB and reassemble the cabinet.
CAUTION! Ensure that no wires are jammed in the cabinet.
Remount the screw in the cabinet.
CAUTION! Tighten the screw carefully - it is screwed into ABS plastic!
15.
Test probe keypad function and output power on an Endolaser 476 at 100% output setting.
16.
Place the Enraf serial number label back and fill in an service report.
17.
CAUTION! Allow the probe to rest up-side-down or with the probe tip pointing upwards for at least 4 hours so that the sealing component is allowed to dry. (This will ensure that sealing component does not flow into the CLB).

SPARE PARTS LIST

The spare parts list on this page shows all available spare parts.
The various columns are explained hereafter:

- Item:** The item number refers to the number on the illustration
- R1:** A number in this column indicates a suggested quantity of spare parts for users
- R2:** A number in this column indicates the minimum recommended quantity for spare parts stock at the local service organisation
- C:** A y(es) in this column marks the so-called "Critical" items. The service engineer must record the type and serial number of the spare part as well as type and serial number of the unit in case of replacement
- Part no.:** The part number column shows the code for ordering the part from Delft Instruments Physical Medicine BV.
- Description:** The description gives additional information to completely identify the part.

Spare parts list

Item	C	R1	R2	Part no.	Description1	Description2
------	---	----	----	----------	--------------	--------------

3444816 Laser probe 780nm, 10mW with target light

NA	N	0	0	3444814	Tool,	safety glasses (set of 2)
NA	N	0	0	3444822	Fluid,	cleaning for Endolaser lenses
NA	N	0	0	3444825	Probe tip,	with coated lens
NA	N	0	0	3444826	Cable,	probe with connectors
NA	N	0	0	3444827	Keypad,	incl. probe cabinet top
NA	N	0	0	3444828	Tool,	probe grounding cable

3444817 Laser probe 830nm, 30mW with target light

NA	N	0	0	3444814	Tool,	safety glasses (set of 2)
NA	N	0	0	3444822	Fluid,	cleaning for Endolaser lenses
NA	N	0	0	3444825	Probe tip,	with coated lens
NA	N	0	0	3444826	Cable,	probe with connectors
NA	N	0	0	3444827	Keypad,	incl. probe cabinet top
NA	N	0	0	3444828	Tool,	probe grounding cable

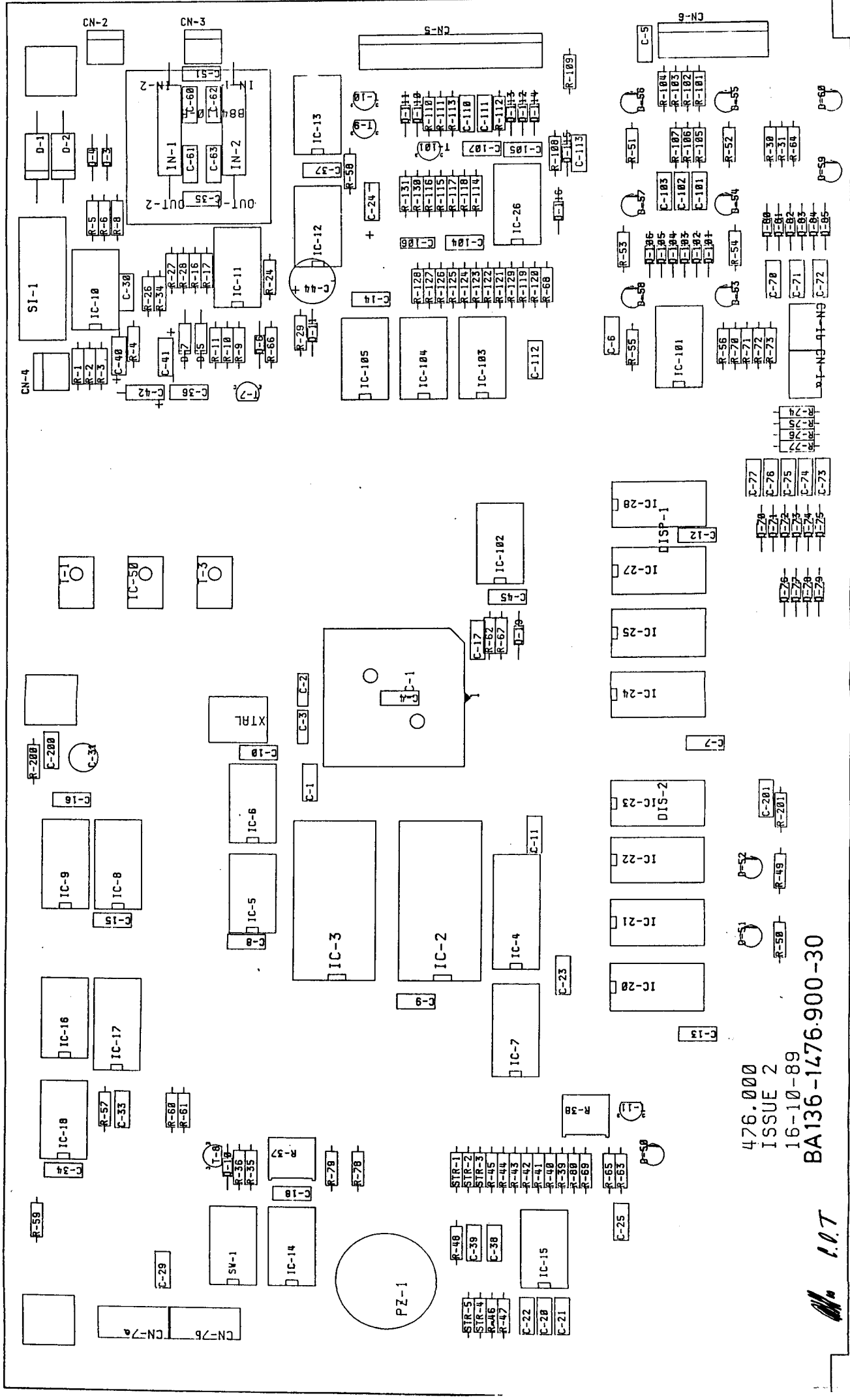

476.000
 ISSUE 2
 16-10-89
 BA136-1476.900-30

Handwritten signature
 I.O.T

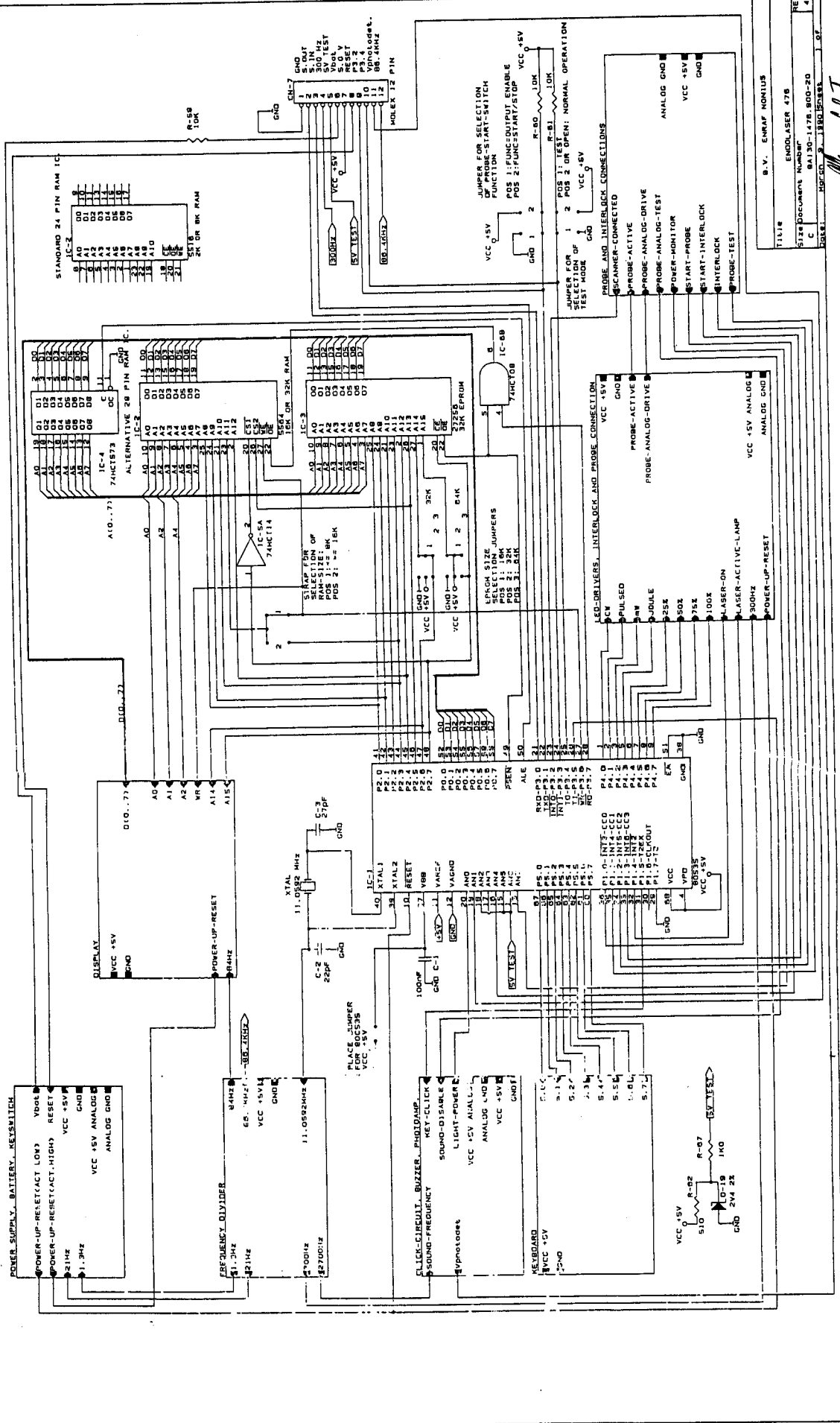

TITLE ENDGLASER 178
 SIZE DOCUMENT 14 1/2" X 17 1/2" 900-20
 C 1
 SHEET NO. 3 OF 4
 DATE 11/7

B. V. ENRAF NOMIUS
 11/7

**POWER SUPPLY
SERIES 0 ONLY**

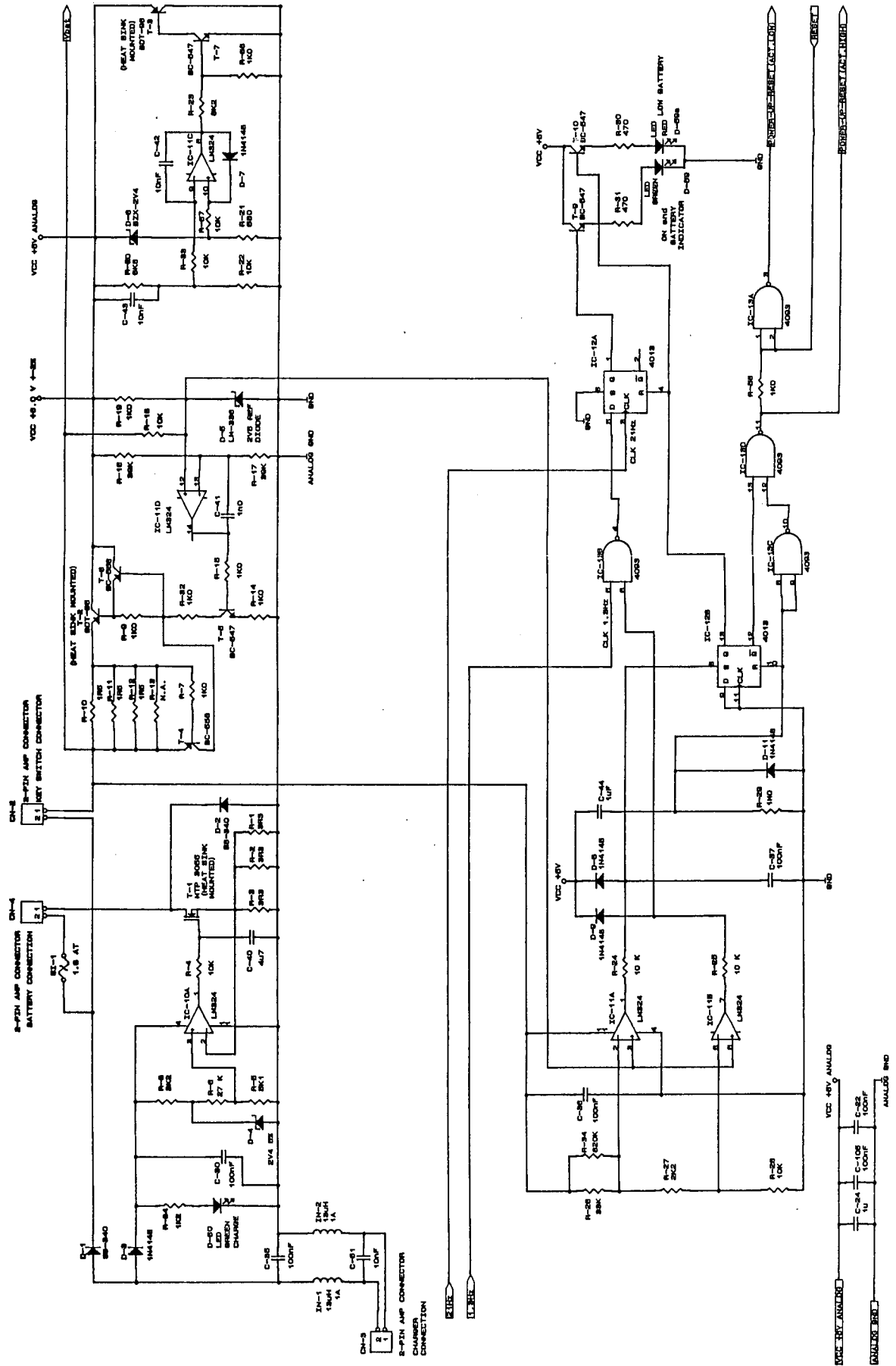

71118 POWER SUPPLY, BATTERY, KEYSWITCH
 5115 DOCUMENT NUMBER
 C
 4750143
 1964-08-24 1000
 2, 27

VCC 48V ANALOG
 ANALOG END
 VCC 48V BATTERY
 BATTERY END
 VCC 48V ANTI-RICOH
 ANTI-RICOH END

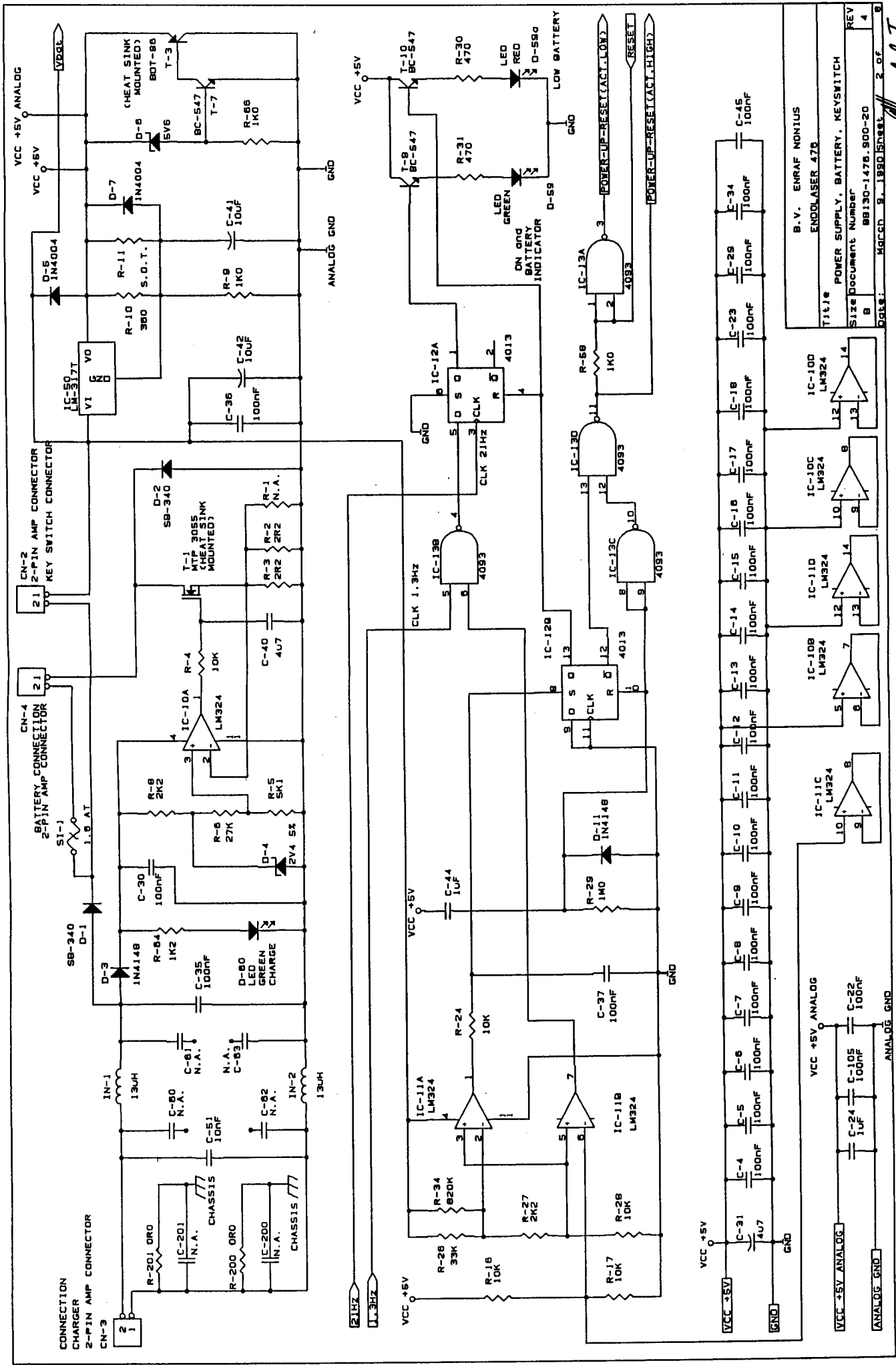

B.V. ENRAF NONTIUS
 ENDOLASER 478
 Title POWER SUPPLY, BATTERY, KEYSWITCH
 Size Document Number 88130-1478-900-20 REV 4
 Date: MARCH 9, 1990 SHEET 2 OF 8

A.O.T

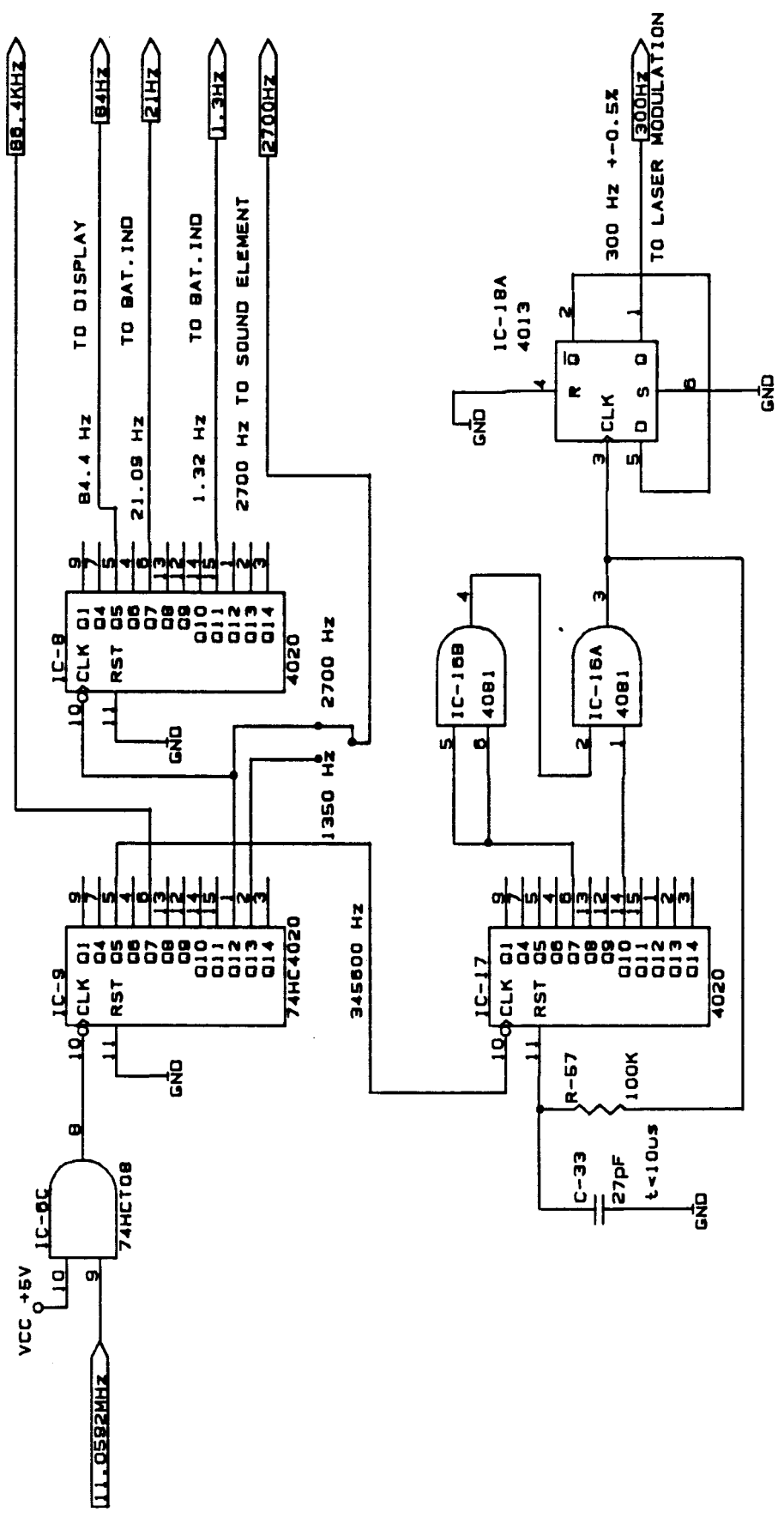

B.V. ENRAF NONIUS	
ENDOLASER 476	
Title	
FREQUENCY DIVIDER	
Size	Document Number
A	BC130-1476.900-40
Date:	March 9, 1990
Sheet	3 of 8
REV	4

[Signature]
P.O.T.

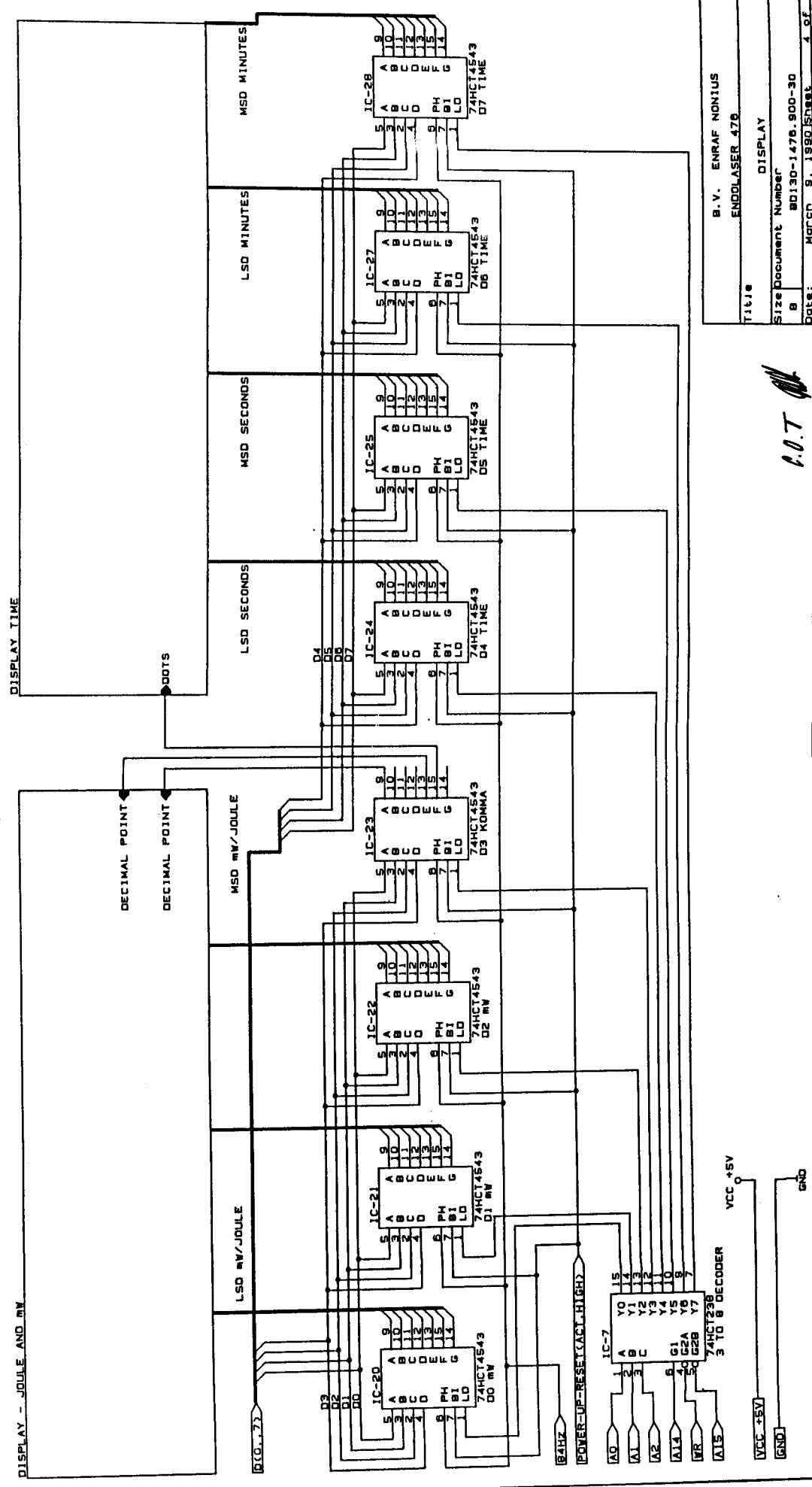

Title		B. V. ENRAF NONTUS ENDLASER 475	
Size		D150-1476.900-30	
REV	4	Doc. Number	8
Date:	MAR 20 9 1990	Sheet	4 of 8

P.O.T.

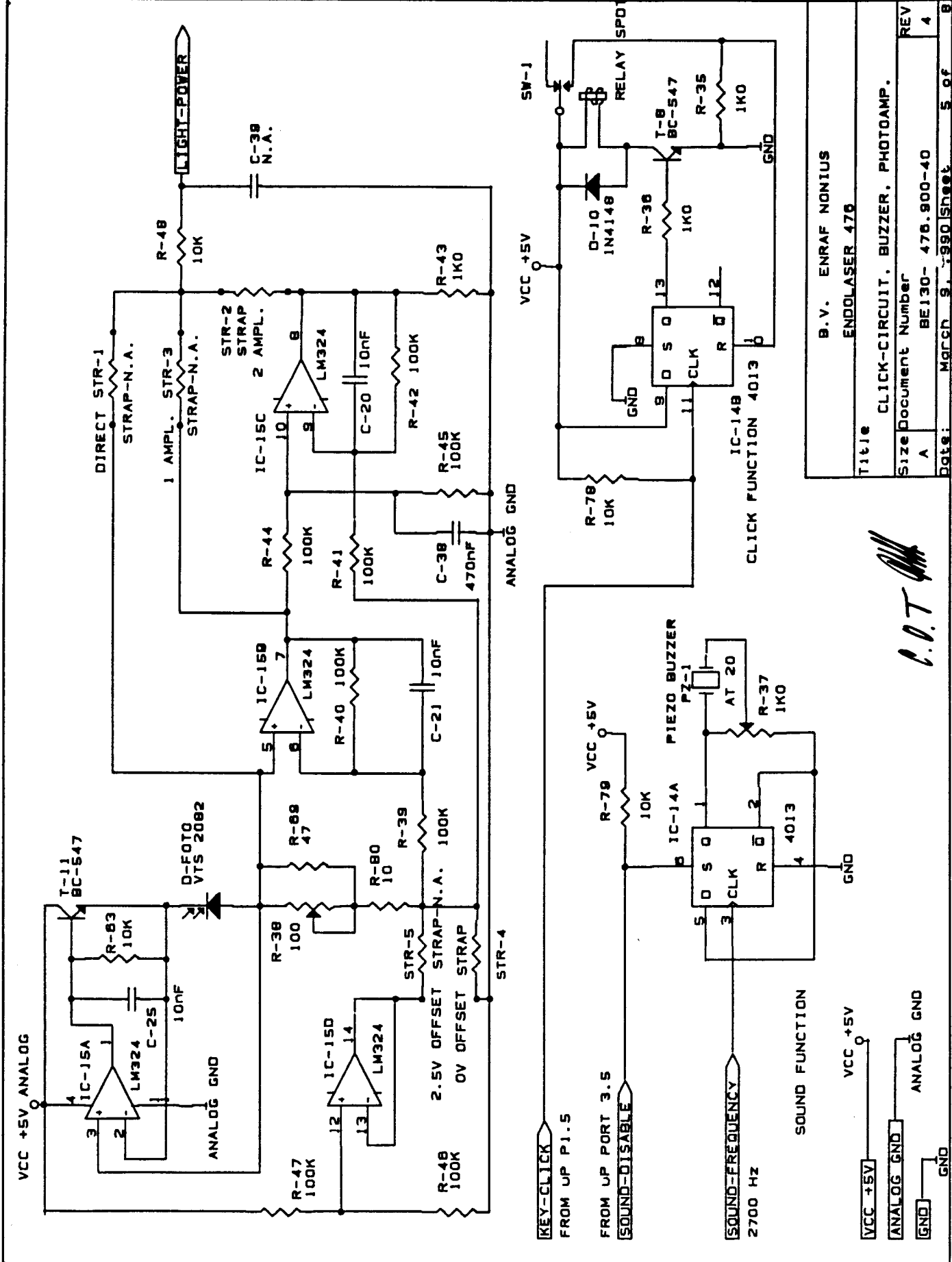

B.V. ENRAF NONIUS

ENDOLASER 478

Title

CLICK-CIRCUIT, BUZZER, PHOTOAMP.

Size Document Number

A BE130- 476.900-40

REV

4

Date:

MARCH 9, 1990 Sheet 5 of 8

C.O.T.

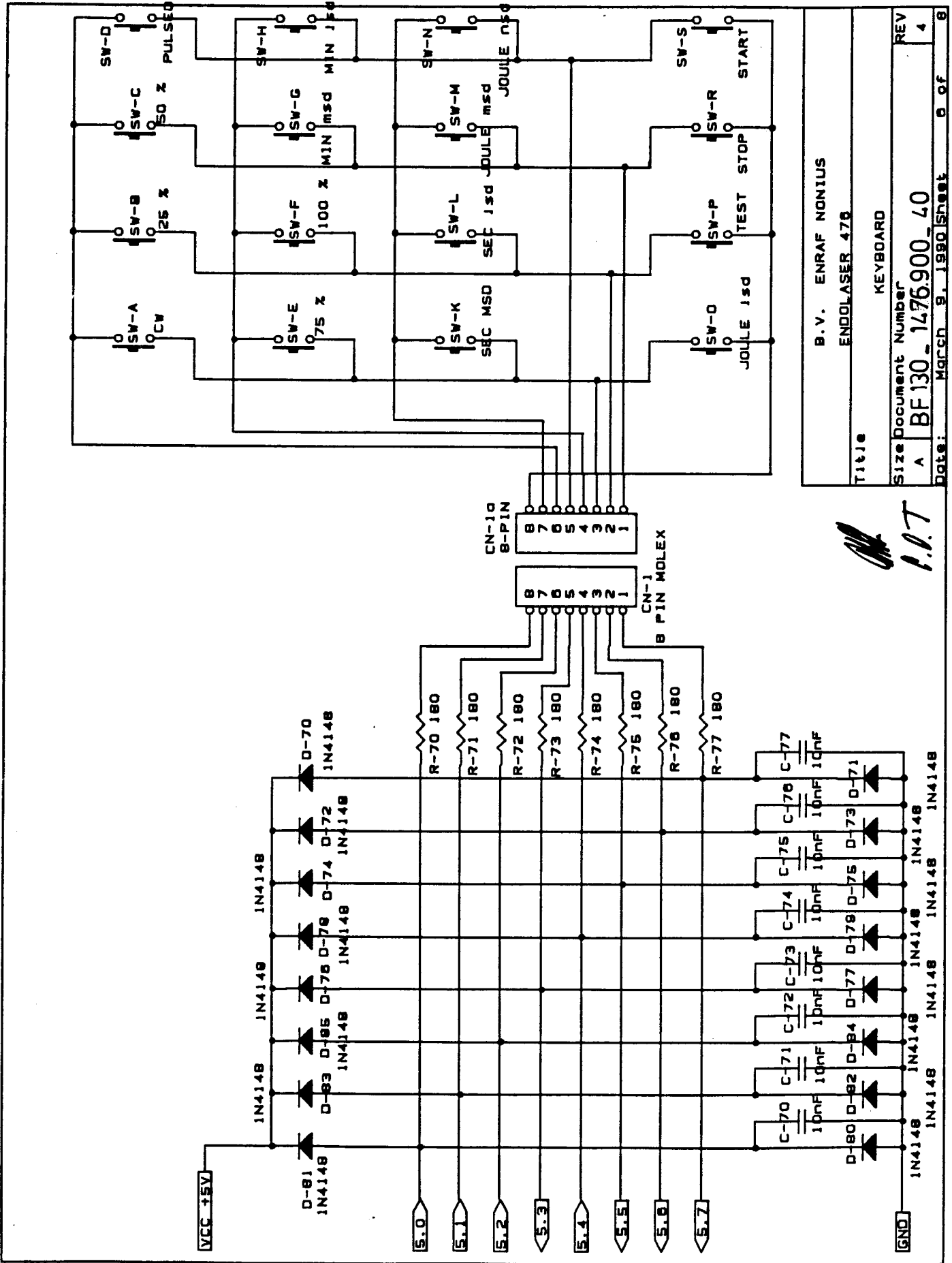

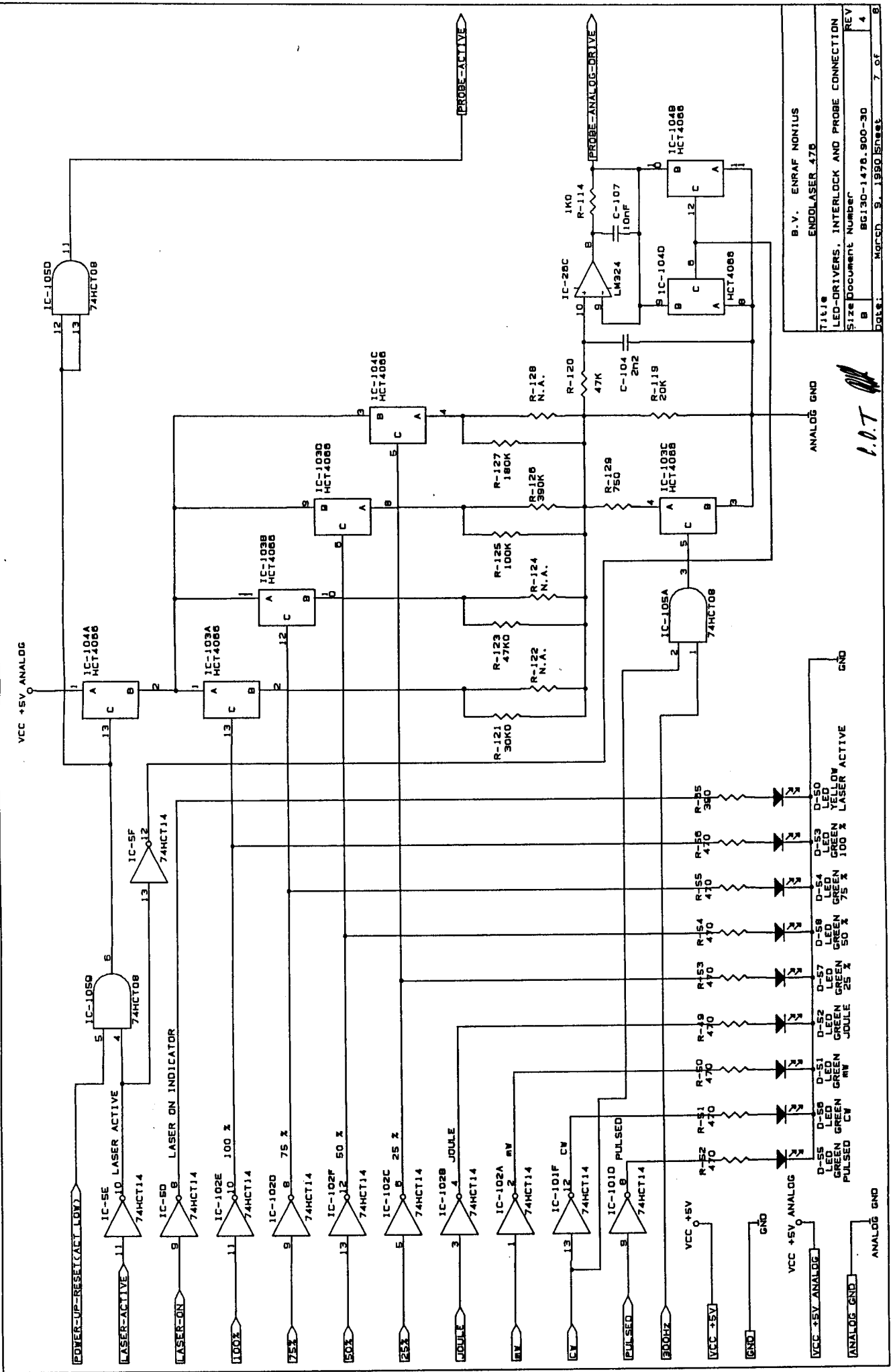

TITLE	B.V. ENRAF NONTIUS
LED-DRIVERS, INTERLOCK AND PROBE CONNECTION	ENDOLASER 478
Size	Document Number
REV	BG130-1476.900-30
REV	4
DATE	MAY 20 9 1990
	Sheet 7 of 8

I.O.T.

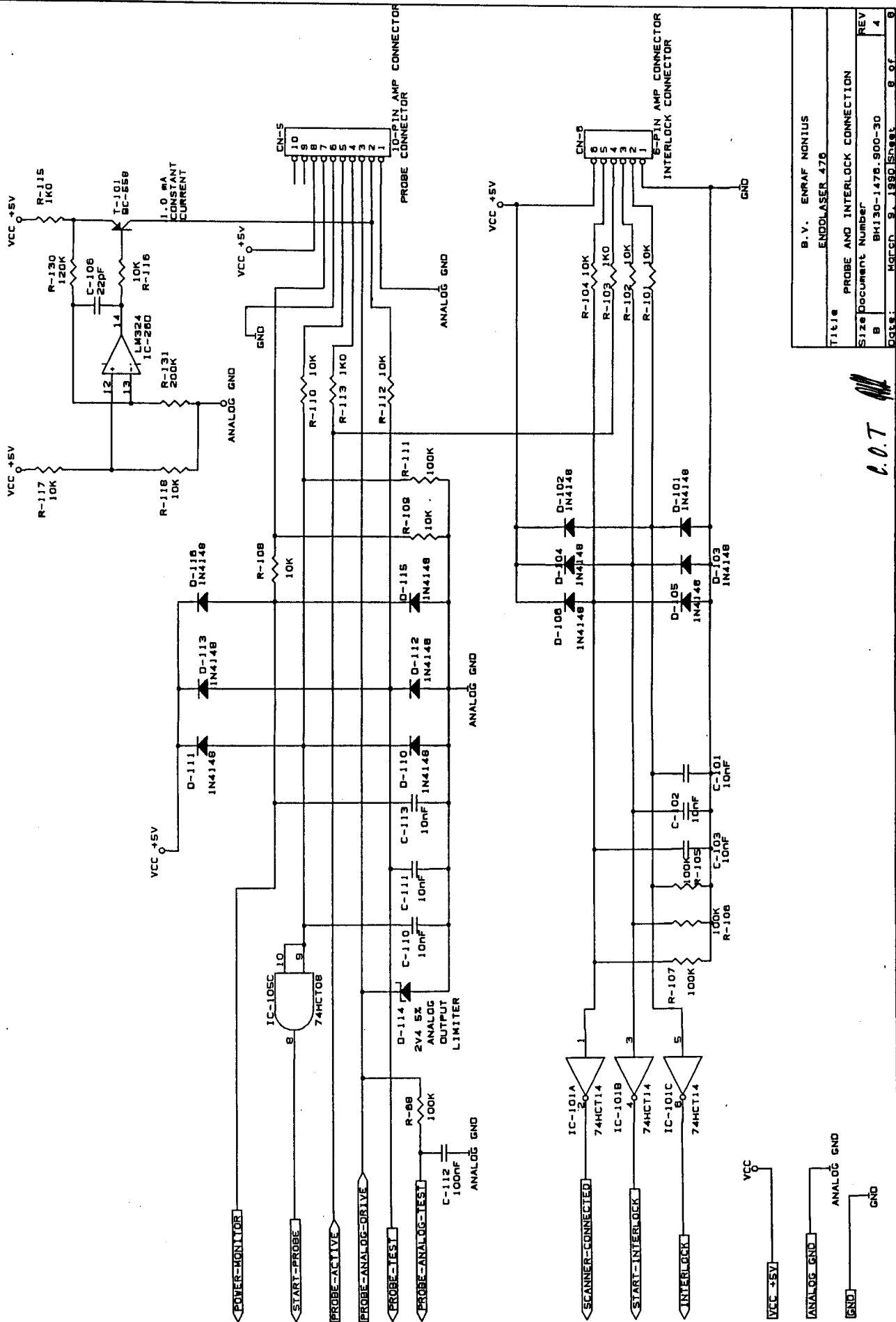

TITLE		B.V. ENRAF NONIUS ENDDLASER 470	
Size	Document Number	PROBE AND INTERLOCK CONNECTION	
B	BH130-1476.900-30	REV	4
DWG.:	DATE: 9. 1990	SCALE:	8 OF 8

C.O.T

Title:

ENDOLASER 476, powermeter failure (lasertest function)

Description:

Some equipments of series 1 may indicate in the laser test function a too high laser output on the display. The meter will show about 1.5 times the real power (15 mW when testing a 10 mW probe, or 45 mW when testing a 30mW probe).

The problem is a fault in the adjustment of the lightsensor circuit. The problem can easily be solved in case the real output power of the supplied probe is known. Solving the problem is done recalibrating the sensor using the probe as a reference. Page 2 of this T.I. gives the measured power of the probes supplied with series 1.

Modification advise

In case of a problem with an Endolaser 476,

-Open the unit.

-Look up the power of the probe in the list at page 2 or 3.

-Perform the laser test procedure (setting 100% / continuous).

-Calibrate the meter with potentiometer R38 ('light sensor') to this value.

In case the supplied probe is not mentioned in the list at next pages, calibrate to the power mentioned at the label of the probe (10, 30 or 40 mW):

Change classification:

- Perform immediately on all field units.
- Perform routinely at next service call.
- Perform only upon unit failure.
- Information only.

Carried out from series	:	does not apply
New components	:	
Deleted components	:	
Updated documents	:	
Our reference	:	

Comment:

The following Endolasers 476 of series 1 may need recalibration:

1, 2, 4, 5, 9, 11, 12, 13, 14, 15, 16, 17, 18, 19, 20
22, 23, 24, 27, 28, 30, 32, 33, 34, 37, 38, 39, 40
41, 42, 43, 45, 46, 47, 47, 48, 49, 50, 51, 52, 54, 56, 58, 59, 60
61, 62, 63, 65, 68, 69, 71, 72, 74, 75, 76, 77, 78, 80
81, 82, 83, 85, 86, 87, 89, 90, 91, 92, 93, 95, 98, 99, 100
102, 103, 104, 105,
152, 154, 187, 201

Power information on laserprobe 3444.816 (10 mW probe)

Number	power(mW)	number	power (mW)	number	power (mW)
01-001	11	01-010	11	01-019	11
01-002	11	01-011	10	01-020	11
01-003	09	01-012	11	01-021	11
01-004	11	01-013	11	01-022	11
01-005	11	01-014	11	01-023	11
01-006	11	01-015	11	01-024	11
01-007	11	01-016	11	01-025	11
01-008	11	01-017	11		
01-009	11	01-018	11		

Power information on laserprobe 3444.817 (30 mW probe)

Number	power(mW)	number	power (mW)	number	power (mW)
01-001	33	01-034	32	01-067	34
01-002	33	01-035	..	01-068	33
01-003	33	01-036	33	01-069	32
01-004	33	01-037	33	01-070	33
01-005	33	01-038	33	01-071	33
01-006	33	01-039	33	01-072	33
01-007	35	01-040	33	01-073	33
01-008	35	01-041	33	01-074	..
01-009	33	01-042	32	01-075	34
01-010	33	01-043	34	01-076	33
01-011	33	01-044	33	01-077	33
01-012	32	01-045	33	01-078	33
01-013	33	01-046	33	01-079	33
01-014	35	01-047	33	01-080	34
01-015	34	01-048	33	01-081	33
01-016	33	01-049	33	01-082	34
01-017	35	01-050	33	01-083	34
01-018	33	01-051	34	01-084	34
01-019	33	01-052	34	01-085	33
01-020	34	01-053	34	01-086	33
01-021	33	01-054	34	01-087	32
01-022	31	01-055	33	01-088	34
01-023	33	01-056	33	01-089	34
01-024	33	01-057	34	01-090	33
01-025	32	01-058	33	01-091	33
01-026	33	01-059	33	01-092	33
01-027	..	01-060	32	01-093	35
01-028	33	01-061	33	01-094	..
01-029	33	01-062	32	01-095	34
01-030	31	01-063	34	01-096	34
01-031	34	01-064	34	01-097	33
01-032	33	01-066	33	01-098	33
01-033	31	01-066	33	01-099	34
				01-100	31

Service Information

ENDOLASER 476, front panel colour change.

Front panel colour

The colour of the front panel of all 4-series equipment has been changed according to the table below:

- | | |
|--|----------|
| 1. Electro therapy equipment | : Blue |
| 2. Ultra sound equipment (and combination equipment) | : Green |
| 3. HF equipment | : Red |
| 4. Myofeedback equipment | : Purple |
| 5. All other types of equipment | : Yellow |

As a result of this, the colour of the frontpanel of the Endolaser 476 has been changed to YELLOW

The spare part number of the new frontpanel is: 0476.801 (not changed).

Please add this page to your service manual.

Change classification

- Perform immediately on all field units.
- Perform routinely at next service call.
- Perform only upon unit failure.
- Information only

Commencing date:	August 1992	
Carried out from series:	NA	
New components:	Front panel (new)	Part no.: 0476.801
Deleted components:		
Our reference: :	NA	



Service Information

ENDOLASER 476, CE marking

The Endolaser 476 equipment produced after March 1996 is sold in the European union with CE marking. The Endolaser 476 complies with all requirements of the EMC Directive (89/336/EEG and 92/31/EEG) using the transition period for the Medical Device Directive (93/42/EEG).

The CE marked equipment can be identified by the following symbol at the rear side of the housing.



For the Endolaser 476 with CE marking the following parts have been added:

- Filter PC Board set: part number: 0476.690

This set contains three filter PC Boards including wiring. For location of the filter PC Boards inside the Endolaser 476 housing see figure 1 at the back side of this service information.

Please add this service info to appendix C of your service manual.

Change classification

- Perform immediately on all field units.
- Perform routinely at next service call.
- Perform only upon unit failure.
- Information only

Commencing date:	March 1996
Carried out from series:	NA
New components:	0476690 (Filter PC Board set)
Deleted components:	NA
Our reference: :	WV 1463.00-60/11

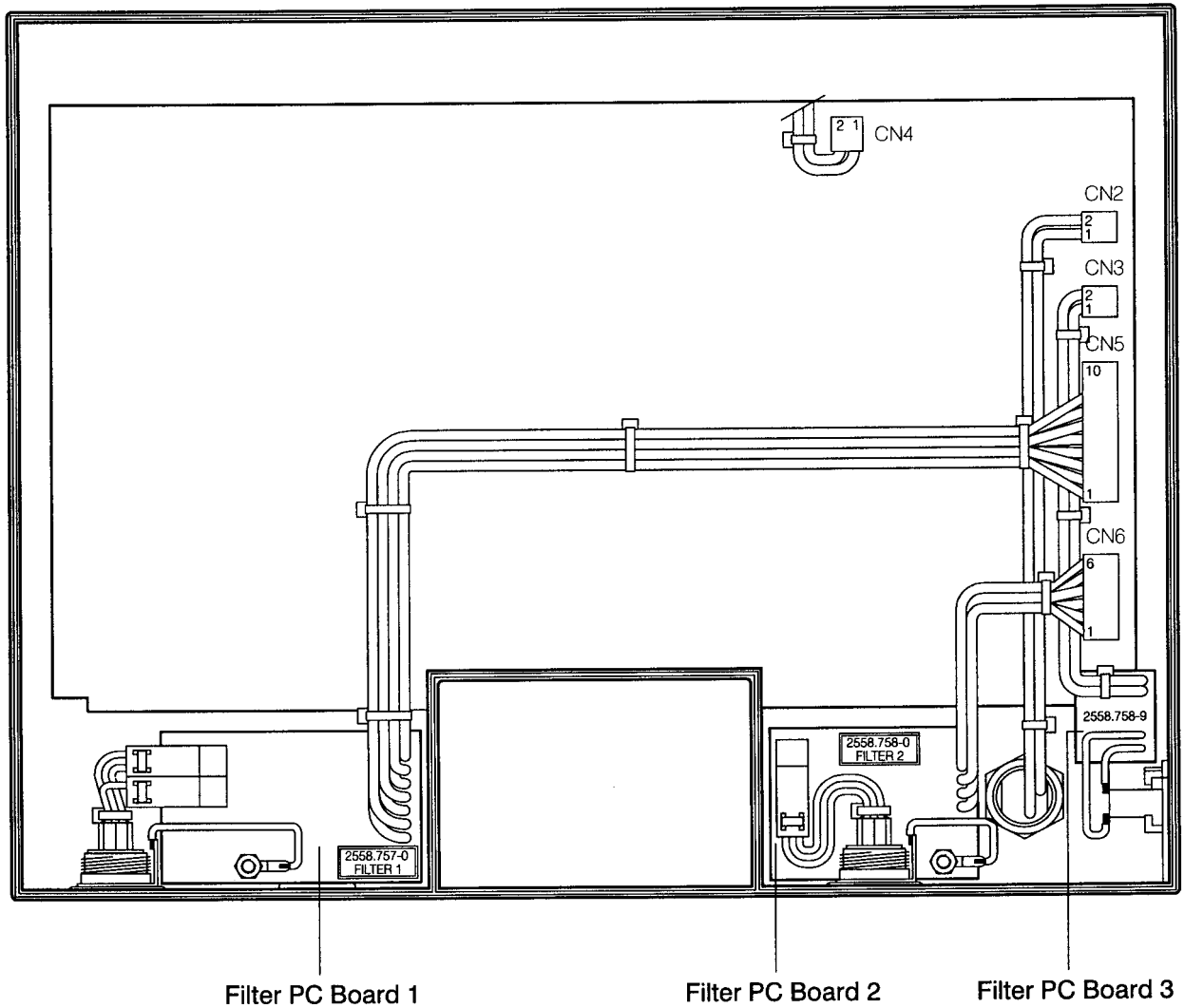

Fig. 1 Location of the EMI filter PC Boards



**Enraf
Nonius**

Enraf-Nonius B.V.
Röntgenweg 1, 2624 BD Delft
Postbus 810, 2600 AV Delft
Tel.: 015 269 87 72
Fax: 015 262 43 49
Handels Register nr.: 260.30.375