



Edition: December 1987

1464.772

SERVICE MANUAL

SONOPULS 464



The information in this manual has been carefully checked and is believed to be reliable; however, no responsibility is assumed for possible inaccuracies or imperfections.

Nothing from this document may be duplicated, copied and/or published in any way whatsoever, without prior written permission from B.V. ENRAF-NONIUS DELFT, Delft, Holland.

CONTENTS

- Preliminary note	page 4
- Introduction	page 5
- Technical Data	pages 6, 7
- Operating Instructions	pages 8- 14
- Important advice for your customer	pages 15, 16
- Block diagram	pages 17- 19
- Circuit description	pages 21- 31
Power supply	page 21
Central control section	pages 21- 24
Microcomputer	pages 21- 23
Program memory	page 23
Address buffer	page 23
Bus buffer	page 23
I/O	page 24
Address decoder	page 24
Analog to digital converter	page 25
Multiplexer	page 25
Digital to analog converter	page 25
Oscillator and divider	page 26
Watchdog	page 26
Current source (US-output)	pages 26, 27
US-output stage	page 27
UTH voltage information	page 28
UTH current information	page 28
Efficiency information	page 28
UTH decoder	page 28
Pulse generator & pulse width modulator	page 29
MF-output stage, 4kHz filter, AC/DC selector, Output on/off	page 29
Phase detector	pages 30, 31
Voltage monitoring circuit	page 30
Current measuring circuit	page 30
- Modifications	page 32
- Warnings	page 33
- How to open the unit	page 33
- Measuring instruments	page 33
- Fault conditions	pages 34- 37
- Test routines	pages 38- 45

- Checks and circuit adjustments	pages 46- 51
General	page 46
Supply voltages	page 46
Circuit adjustments	pages 47- 51
General	page 47
Adjustment of the battery charging current	page 48
Adjustment of the maximum MF output current	page 48
Check/adjustment of the ultrasound output stage and the ultrasound output power	page 48
Instructions to repair and calibrate a treatment head	pages 50, 51
Function test	pages 52, 53
- Maintenance	page 54
File of maintenance and repairs	page 55
- Layout for circuit adjustments	page 55
- P.C. Board 1, layout	page 56
- Construction drawings and photos	pages 57- 66
Housing, sectional drawing	page 57
Front panel	page 58
Interior	page 59
Battery charger	pages 60, 61
Ultrasound treatment heads	pages 62, 64
Accessories	page 65
Recommended tools	page 66
- Spare parts list	pages 67- 81
How to order spare parts	page 82
- Enclosures:	
Circuit diagram BA.130.1464.900.10	
Circuit diagram BB.130.1464.900.10	
Circuit diagram BC.130.1464.900.40 (treatment heads)	
Appendix BD.130.1464.900.40 (pin designation semiconductors)	

THIS MANUAL IS MEANT FOR AUTHORIZED ENRAF-NONIUS SERVICE DEALERS.

PREMATORY NOTE

To survive as a manufacturer or distributor of electro-medical equipment, an excellent and adequate after-sales service is necessary.

Therefore factual knowledge and professional skill of the service engineers are as well important as having the disposal of accurate measuring equipment and sufficient tools, an adequate spare parts stock and last but not least being in good terms with your customer.

All that will help to do things right the first time which - in our opinion - should be the slogan of our total service network.

This manual therefore includes operating instructions, technical data, maintenance and all that which can be useful for a deeper understanding of the after-sales service.

The introduction gives a general idea of what the unit is all about and what kind of unique features are involved.

We hope that this manual enables you to execute adequate service in the full sense of the word.

If you have remarks and/or suggestions, please write to ENRAF-NONIUS B.V., Medical Service Documentation Department, P.O.BOX 483, 2600 AL DELFT, HOLLAND.

INSTRUCTION MANUAL

For operating instructions we refer to the instruction manual 1464.750.

The information in this manual has been carefully checked and is believed to be reliable; however, no responsibility is assumed for possible inaccuracies or imperfections.

Nothing from this document may be duplicated, copied and/or published in any way whatsoever, without prior written permission from B.V. ENRAF-NONIUS DELFT, Delft, Holland.

INTRODUCTION

The SONOPULS^R 464 is a portable microcomputer-controlled unit for ultrasound therapy and therapy with medium-frequency current.

The unit is battery powered, with a splashproof housing, enabling it to be used independently of the mains power supply and in "wet rooms". The light weight and compact dimensions of the unit make it suitable for many applications, including the treatment of injuries during sports events.

All functions of the unit are controlled and monitored by a built-in microcomputer, ensuring a high degree of reliability and safety.

The unit provides the following possibilities: continuous or pulsed ultrasound at a frequency of 1MHz, medium-frequency alternating current, medium-frequency direct current or a combination of ultrasound with either of the two current types.

The medium-frequency alternating current can be used for two-pole interferential therapy. The current can be modulated with a frequency adjustable between 0 and 150Hz (AMF). In addition a sweep frequency (spectrum) can be adjusted between 0 and 100Hz.

Thanks to the carrier frequency of 4 kHz, the medium-frequency direct current has a greater depth effect and less galvanic effects than a low-frequency direct current. The base AMF and sweep frequency can be controlled separately.

The output characteristics of the unit makes it possible to place or remove the electrodes during treatment without causing shocks. Therefore, the SONOPULS^R 464 is highly suitable for use in combination therapy.

The treatment heads have excellent beam characteristics, fully meeting the requirements of the existing standards. The treatment heads are available with effective radiating areas (ERA) of 5 cm² and 0.8 cm². During treatment, the contact control will be functioning: if the acoustic contact is poor, the intensity will be reduced automatically and the treatment timer will stop. In case of combined therapy the current will decline slowly in order to prevent unacceptably high current densities.

The heads are fully interchangeable, enabling them to be connected to any SONOPULS^R 464 unit without individual recalibration. The heads are also interchangeable with those of the SONOPULS^R 434 and 463.

TECHNICAL DATA

Battery charger

Mains voltage	: available for 110V, 220V or 240V, 50...60Hz.
Permissible variation	: $\pm 10\%$
Current consumption	: 0.065A (220V version)
Max. output current	: 400mA
Max. output voltage	: 14.0 V
Safety class	: II type BF*)
Patient leakage current	: Typically 5 uA (IEC requirement $\leq 100\mu\text{A}$)
Patient leakage current under single fault condition	: Typically 5 uA (IEC requirement $\leq 500\mu\text{A}$)

Treatment unit

Ultrasound frequency	: 1MHz
Ultrasound output	: - continuous wave, - pulsed wave (100Hz $\pm 5\%$), 2ms $\pm 5\%$ pulse duration, 8ms $\pm 5\%$ pulse interval.
Ultrasound intensity	: continuously adjustable; continuous wave: 0.05 - 1 W/cm ² , pulsed wave : 0.15 - 3 W/cm ² .
Contact control threshold level	: 80% of initial value set.
Current types	: medium-frequency alternating current, medium-frequency direct current.
Carrier frequency	: 4kHz (+250Hz/-500Hz).
Base AMF	: 0 - 150Hz, continuously adjustable.
Spectrum AMF	: 0 - 100Hz, continuously adjustable.
Spectrum program	: linear 6/6s.
Current intensity	: 0 - 100mA $\pm 5\%$ (peak value)
Output characteristics	: constant current up to 750 Ohms (above this impedance the behavior is more of a constant voltage nature).
Max. output voltage	: 75V (top).
Display	: treatment time (minutes) or intensity (W/cm ²) or total power (W).
Timer	: 0 to 15 minutes, coupled to contact control, switches off the ultrasound and the current automatically at the end of treatment time.
Safety class	: II type BF*).
Patient leakage current	: typically 5 uA (IEC requirement $\leq 100\mu\text{A}$).
Patient leakage current under single fault condition	: typically 5 uA (IEC requirement $\leq 500\mu\text{A}$).
Battery	: 12V, 1.8Ah maintenance-free lead accumulator; dim. 178.5 x 34 x 60.5 mm (l x w x h).
Dimension	: 34.5 x 27 x 10 cm (w x d x h).
Weight	: 3.1 kg

*) II indicates that the apparatus is double insulated.

BF indicates that the equipment has a floating patient circuit, in which the leakage currents meet the requirements of IEC 601-1.

Treatment heads

1MHz, large	: Surface area	: 6.2 cm ²
	ERA*	: 5.0 cm ²
	BNR**	: max. 6.0
	Beam type	: collimating
Parasitic side radiation		: max. 10mW/cm ²
1MHz, small	: Surface area	: 1.4 cm ²
	ERA*	: 0.8 cm ²
	BNR**	: max. 6.0
	Beam type	: diverging
Parasitic side radiation		: max. 10mW/cm ²

* ERA is the Effective Radiating Area of the treatment head.

** BNR is the Beam Non-uniformity Ratio. This is the ratio between the peaks and the average value of the intensity in the ultrasound beam. A low BNR excludes the possibility of undesirably high energy concentrations in the beam.

ERA and BNR are measured according to FDA methods.

All treatment heads are provided with contact control.

The SONOPULS 464 was built in accordance with the safety standards IEC 601-1/601-1-5, TÜV/Rheinland, SEV and FDA. Test reports are available on request.

IMPORTANT NOTE: for technical data, stated in accordance with the FDA regulations, we refer to the technical data as mentioned in the Instruction Manual.

OPERATING INSTRUCTIONS

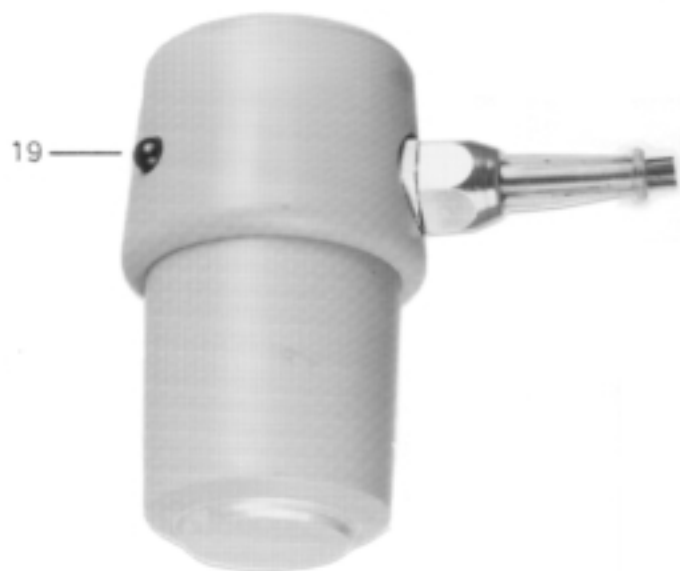
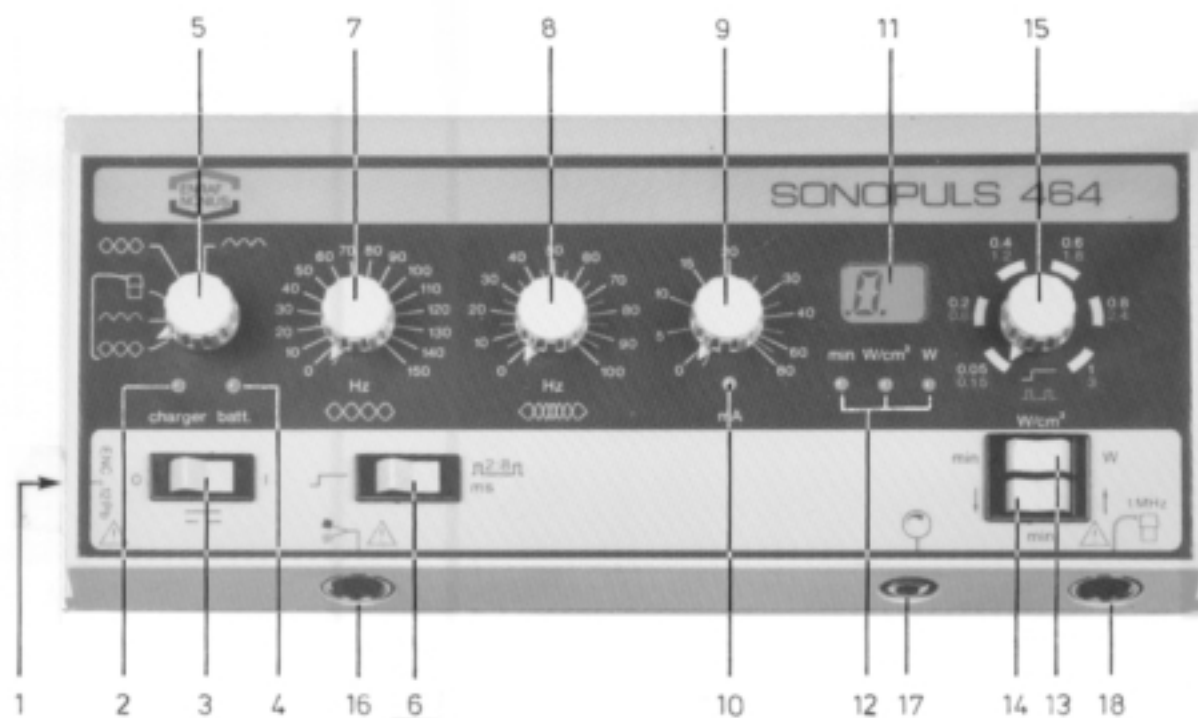

CONTROLS

1. Connection for battery charger
2. Charger indicator lamp
3. ON/OFF switch
4. Battery charge indicator lamp
5. Selector switch therapy-form
6. Selector switch ultrasound mode
7. Base AMP control
8. Sweep frequency (spectrum) control
9. Current intensity control
10. Warning lamp ZERO current output
11. Display
12. Indicator lamps for display mode
13. Display mode selector switch
14. Time setting switch
15. Ultrasound intensity control
16. Connection for patient cable
17. Connection for current intensity remote control
18. Connection for treatment head
19. Contact control indicator lamp_s

DESCRIPTION OF CONTROLS

[1] Connection for battery charger

If circumstances permit, keep the battery charger connected during use to conserve the battery.



Connection of a battery charger other than the prescribed (type ENC 12 Pb) can adversely affect the safety of the patient and the functioning of the unit, and is therefore not permitted.

[2] Charger indicator lamp ('charger')

The lamp lights to indicate that the charger connected is functioning correctly.

[3] ON/OFF-switch

Switch ON : press the switch to the right (I).
Switch OFF: press the switch to the left (O).

Internal test. Directly after switching on, the unit carries out a "self-test" for a period of two seconds. During this period the microcomputer automatically tests a number of important functions of the unit. At the conclusion of the test, a buzzer sounds and the desired settings can be made. During the self-test all lamps light, and the display indicates '.8.8'.

[4] Battery charge indicator ('batt')

The lamp provides a general indication of the battery charge. There are four indications:

- continuous green light : battery fully charged;
- flashing green light : battery partially discharged;
- red light* : battery insufficiently charged;
- lamp out : battery fully discharged.

*) The current output declines slowly and the unit switches off automatically; the treatment cannot be continued, first charge the battery.

[5] Selector switch therapy-form

The following therapy-forms can be selected:

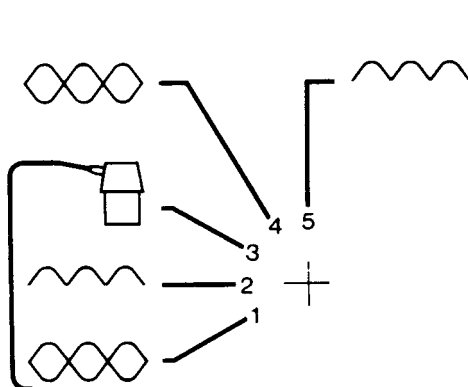



1. Combined therapy, ultrasound with medium-frequency alternating current.

2. Combined therapy, ultrasound with medium-frequency direct current

3. Ultrasound therapy.

4. Medium-frequency alternating current.

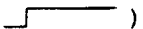
5 Medium-frequency direct current

- [6] Selector ultrasound mode
 Continuous ultrasound (CW): press switch to the left ().
 Pulsed ultrasound (PW): press switch to the right ().
 In the pulsed ultrasound mode, the pulse repetition frequency is 100 Hz, with a pulse duration of 2 ms and a pulse interval of 8 ms (2:8).

- [7] Base AMF control
 Control for the base amplitude modulation frequency. The amplitude of the carrier wave (4kHz) is modulated by the set frequency. The AMF is continuously adjustable between 0 and 150Hz.

Note: the unit switches automatically to a 0% modulation when an AMF of less than 1Hz is adjusted.

- [8] Sweep frequency (spectrum) control
 Makes it possible to adjust a continuously varying AMF, the so-called spectrum. This spectrum is superimposed onto the base AMF. The spectrum frequency is continuously adjustable between 0 and 100Hz. The spectrum has a linear drift, and is run in 6 seconds (6/6).

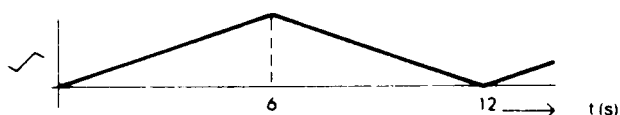

- [9] Current intensity control
 The patient current is adjustable between 0 and 100mA (peak value). The control has a logarithmical drift. The current can only be adjusted from the zero position (first turn the control completely anti-clockwise). It is also possible to set the current with a remote control, see [17].

- [10] Warning lamp ZERO current output
 The apparatus is protected against a number of (erroneous) operations. This is the case if with adjusted intensity:

- a) the unit is switched on;
 - b) the remote control is connected or disconnected (17);
 - c) the selector switch for therapy form [5] is turned;
- or if:
- d) the treatment time has not been adjusted, or has elapsed;
 - e) the battery is not sufficiently charged (see also indicator lamp [4]);

The indicator lamp will light and no output current is supplied.

To reset the safety device proceed as follows:

Item a-c: first turn the intensity switch to the 'ZERO' position.
 Hereafter readjustment of the apparatus is possible.

Item d : adjust the treatment time.

Item e : switch off the unit and charge the battery.

[11] Display

The following parameters can be indicated on the display:

- treatment time in minutes (min);
- the ultrasound intensity in W/cm^2 ;
- the ultrasound power in Watt (W).

Select the required display mode with the display mode selector [13]. The selected mode is indicated by one of the indicator lamps [12].

Display of treatment time: If the clock is running, the left point on the display will flash.

Display of US intensity/power: In case of insufficient contact between the treatment head and the skin, the original set value is indicated and the display is flashing.

<u>Ultrasound mode</u>	<u>display function</u>	<u>display indicates</u>
Continuous wave	W	The average ultrasonic power in the continuous mode
Continuous wave	W/cm^2	The average effective intensity in the continuous mode
Pulsed wave	W	The peak pulse ultrasonic power in the pulse-modulated mode
Pulsed wave	W/cm^2	The peak pulse effective intensity in watts per square centimetre in the pulse-modulated mode

[12] Indicator lamps for display mode

The selected display mode is indicated by the corresponding lamp lighting:

- lamp 'min' :display indicates treatment time;
- lamp ' W/cm^2 ' :display indicates ultrasound intensity;
- lamp 'W' :display indicates ultrasound power.

[13] Display mode selector switch

Use this switch to select the required display mode:

- left position 'min' : for indication of treatment time;
- mid position ' W/cm^2 ' : for indication of ultrasound intensity;
- right position 'W' : for indication of ultrasound power.

[14] Treatment time selector switch

Set the display mode selector switch [13] to position 'min'.

Setting: push the switch to the right (↑).

The maximum time that can be set is 15 minutes, in steps of 1 minute.

Reducing time set: push the switch to the left (↓).

from 15 to 10 minutes: in steps of 1 minute;

from 10 to 0 minutes: in steps of 30 seconds.

Press the switch once for each step. For fast setting, keep the switch pressed in until the required time is indicated.

The time can be set directly from 0 to 15 minutes by pushing the switch once to the left.

When the switch is released the timer begins to run. If the contact between the treatment head and the skin becomes inadequate, or if the safety device has been activated, the timer stops automatically.

Note: In case of ultrasound therapy and combined therapy, the treatment time can only be set if a (1 MHz) treatment head is connected.

[15] Ultrasound intensity selector

The intensity selection is linear and stepless.

The intensity for continuous ultrasound is adjustable between 0.05 and 1 W/cm²;

for pulsed ultrasound between 0.15 and 3 W/cm².

The approximate intensity can be set using the scale divisions, with the exact intensity shown on the display [11].

[16] Connection for patient cable

In therapy with medium-frequency rectified alternating current the red plug of the patient cable is positive, and the black plug is negative.

In combined therapy with medium-frequency direct current the red plug is positive, and the treatment head is negative.

The SONOPULS^R 464 can also be used in combination with the VACOTRON 436 (suction unit). In that case use the special connection cable (see Spare Parts List, Accessories).



Connect only Enraf-Nonius equipments of the BF-type to the Sonopuls 464 since the minor leakage currents of our instruments guarantee absolutely safe therapy.

[17] Connection for remote control

If desired a remote control can be used to set the patient current. Use the standard remote control 1404.800 or the programmable remote control 1438.800.

When the remote control is connected, the current intensity control on the apparatus is automatically switched off.



Connection of remote controls other than those prescribed by ENRAF-NONIUS can adversely affect the safety of the patient and the functioning of the unit, and is therefore not permitted.

[18] Connection for treatment head

The connection is intended for a large or small 1 MHz treatment head. 1MHz treatment heads of the SONOPULS^R 434 or SONOPULS^R 463 can also be connected without any calibration.



Connection of treatment heads other than those specified by Enraf-Nonius (1MHz) can adversely affect the safety and the functioning of the unit, and is therefore not permitted.

[19] Contact control indicator lamps

If there is adequate contact between the treatment head and the skin, the indicator lamps on the treatment head are out.

If the contact becomes inadequate, the lamps light, the timer stops, and the intensity is automatically reduced to a very low value (ca. 0.05W/cm²).

If the intensity or power display mode has been selected, then the display will show the set value flashing.

In case of combined therapy the current will decline, in order to prevent unacceptably high current densities.

MISCELLANEOUS

Type plate

The type plate provides all information identifying the equipment, such as type, version and serial numbers. The plate is on the underside of the unit.

Handgrip

A recessed handgrip is provided on the underside of the unit, near the front.

Cover (optional)

Use the cover when the unit is being transported, or is not in use. To remove the cover see below.

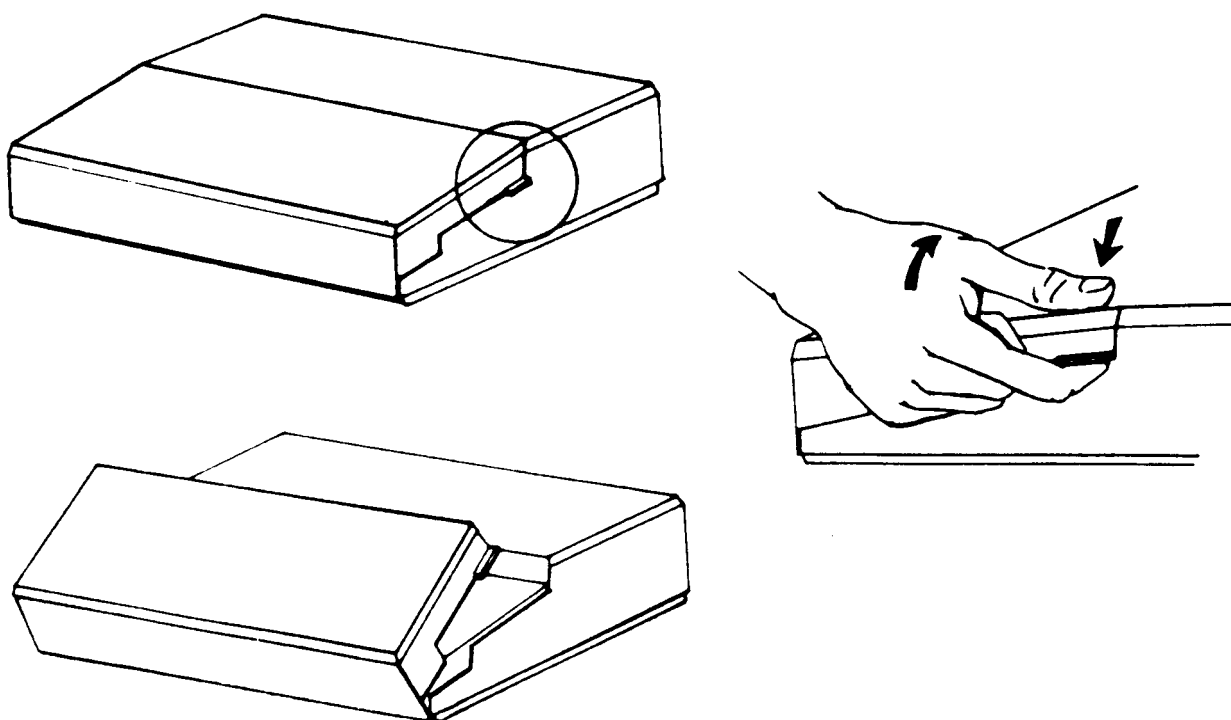

Battery compartment

The battery compartment is found at the back of the apparatus. For opening the battery compartment, see below.

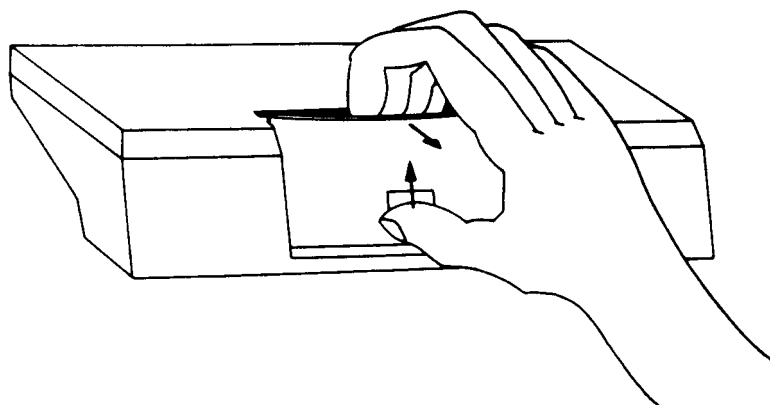

IMPORTANT ADVICE FOR YOUR CUSTOMER

The SONOPULS 464 is a modern, safe and easy to handle apparatus, which is developed, produced, calibrated and packed with greatest care and attention. The unit has several approvals such as TÜV/GS and SEV.

Enraf-Nonius can not be held responsible for any discomfort to the operator or to the patient due to faulty diagnosis, misuse or mishandling of the equipment and/or accessories, misunderstanding of the operating procedures, faulty connections with equipment that does not comply to the I.E.C. 601-1 regulations for type BF equipment, or due to careless maintenance.

To prevent any of these situations, we strongly advise to read the instruction manual carefully BEFORE putting the equipment into use.

Make sure that the instruction manual is available at any time for all personnel involved. Further we advise to keep your equipment under service-maintenance by your local qualified service office.

It is not allowed for unqualified personal to open the equipment for any reason whatsoever.

Use only the original battery charger in combination with this unit. Check whether the required mains voltage and frequency, mentioned on the type plate of the battery charger, corresponds with the available mains supply ratings. We advise to keep the battery charger connected to the unit as much as possible.

To prevent Electromagnetic Interference keep at least 3 meters distance between the SONOPULS 464 and shortwave or microwave therapy equipment. Under worse conditions with respect to HF interference, disconnect the battery charger and use the unit on battery power only (for more detailed information see instruction manual SONOPULS 464).

Good air circulation is essential to prevent internal heat build-up in the unit. Place the unit in a location with adequate air circulation. Do not install the unit near heat sources such as radiators or air ducts, or in a place subjected to direct sunlight, excessive dust, mechanical vibration or shock.

Should any liquid fall into the cabinet, switch off the unit, disconnect the battery charger and have the set checked by your nearest authorized service dealer before operation.

MAINTENANCE (by the user)

Before cleaning and other maintenance of the SONOPULS 464, first turn off the apparatus, unplug the battery charger from the mains and disconnect the battery charger from the unit.

Apparatus

The unit can be cleaned with a damp cloth using a non-abrasive liquid household cleanser (maximum temperature: 60°C). The plexiglass cover should only be gently cleaned with a soft damp cloth to prevent scratches.

The housing material is proof against dilute acid, neutral and acid salt solutions, fat and alcohol.

However, it is not proof against ammoniacal solutions, acetone, and some kinds of industrial oils, grease and gasoline (petrol).

Treatment heads

Clean the surface immediately after ending the treatment. Make sure that no ultrasonic gel remains on the treatment head. We further advise cleaning the total head and cable, preferably daily, using lukewarm water. If necessary, a household liquid cleanser may be added.

The housing material of the treatment heads is proof against dilute acid, neutral and acid salt solutions, fat and alcohol. However, it is not proof against ammoniacal solutions, acetone, and some kinds of industrial oils, grease and gasoline (petrol).

Avoid contact of the cables with gel, grease or oil.

The treatment heads should be regularly inspected for damage, e.g. hairline cracks, which could allow penetration by liquids. The cables and connectors of the treatment heads should also be regularly inspected. Care must be taken when handling the treatment heads, as rough usage could adversely affect their characteristics.

Disinfect the treatment heads using a cloth dampened with 70% alcohol.

BATTERY

The SONOPULS 464 was designed to be battery-operated during the whole day, under normal circumstances.

We advise charging the battery overnight. The charging time will then generally be more than adequate. However, in the case of a completely exhausted battery (batt. indicator is out), the charging time can be longer, e.g. 15 - 20 hours.

Switch off the SONOPULS 464 during charging. Ensure that the charger indicator lamp is lit, indicating that the charger is functioning correctly.

BLOCK DIAGRAM

(see page 19)

All functions of the Sonopuls 464 are controlled by the CCS (Central Control Section) which is composed of the uCOM (microcomputer), EPROM (program memory), latch/buffer and I/O (In/Output ports).

The parameter settings are read by the ADC (Analog to Digital Converter), converted into a digital value and sent to the CCS. Together with feedback signals from the output circuits (current info, voltage info), this information is used for controlling the US-output power, MF-current intensity and for updating the display.

For driving the US-output, the DAC (Digital to Analog Converter) converts the digital value, generated by the CCS, into an analog voltage level. This signal drives the current source and is continuously monitored by the CCS via the ADC. To obtain high efficiency the current source is of a switched type. The current source controls the output power through the output stage.

To obtain high efficiency the US-output stage is switched at a frequency of 1MHz. The harmonics of the 1MHz block signal are suppressed by a filter and the resulting sinusoidal current used as supply current for the UTH (Ultrasound Treatment Head). Because of the current source, the output stage is also of a current source nature. The UTH supply current is measured by the current information circuit and the result is feedback to the CCS via the ADC for monitoring and any necessary correction.

The impedance of the UTH depends on the level of acoustical contact between the treatment area of the UTH and the skin of the patient; with optimum acoustical contact the impedance is maximum. If, because of poor acoustical contact, the impedance of the piezo element (crystal) is considerably lower than when there is optimum contact, then the CCS will reduce the US output power to a certain minimum value and the contact indicators on the treatment head lit, the display will show the preset intensity/power flashing and the timer stops.

The level of acoustical contact is measured by the voltage information circuit. This circuit measures the voltage across the piezo element. Because the UTH is driven with a constant current, the UTH-voltage depends on the impedance of the piezo element, i.e. depends on the level of acoustical contact. Hence, the output voltage of the voltage information circuit is a measure for the level of acoustical contact. This signal is feedback to the CCS via the ADC and is used to update the display and for monitoring.

Treatments heads may differ in efficiency (and impedance). The CCS automatically adapts the UTH supply current to the efficiency of the treatment head. By doing so, the treatment heads of the Sonopuls 464 are interchangeable without recalibration. Information about the efficiency factor is included in each head and is represented by a resistance value which is set at the works with trimmer potentiometer Pcal. Via the efficiency information circuit and the ADC, the CCS reads this resistance value. With this information the CCS can computerize the amplitude of the supply current which is required for the desired acoustical output power. This means that when a treatment head with a low efficiency factor is connected, the Sonopuls automatically supplies a higher drive current than when a head with a high efficiency factor is connected.

As the CCS has information about UTH-voltage, UTH-supply current and UTH-efficiency, the CCS can computerize the real acoustical output power. During treatment this value is shown on the display.

Inside the plug of the UTH there is a resistor which is to inform the CCS about the type of treatment head that is connected. There are two resistor values for the two different types of treatment heads. Via the UTH-decoder and the ADC, the CCS reads this resistance value. This information is required for supplying the correct level of drive current.

The MF-output stage is of a switched type and is in resonance for the carrier wave of 4kHz (3500...4250Hz). The carrier wave is generated by the PWM (Pulse generator/Pulse Width Modulator). The duty cycle of the 4kHz block pulses lies between 0 and 50% and is decisive for the intensity of the output current (50% resulting in max. output current). When an AMF (Amplitude Modulation Frequency) is set, then the duty cycle continuously varies in the rhythm of the AMF set resulting in an amplitude modulated signal.

The pulses from the PWM are fed via the output stage to a 4kHz LC-filter. Only the fundamental frequency, a 4kHz sinusoidal signal, passes the filter. This signal, the patient current, is routed via a rectifier- and output on/off circuit to the patient.

For the supply of sufficient output power and for a high efficiency, the output circuit must be in resonance. The resonance frequency of the output circuit depends on the 4kHz LC-filter but also on the patient's impedance. The patient's influence can be explained because the patient forms a parallel capacitor to the LC-filter. Because the patient's impedance is undefined and may even change during treatment, the resonance frequency cannot be specified exactly. Therefore, to keep the circuit in resonance, the CCS continuously adapts the frequency of the carrier wave to the resonance frequency of the output stage.

This is done with the aid of the phase detector which measures the phase angle between the drive signal (from the PWM) and the output signal of the output stage (patient current). When the output circuit is in resonance, then the phase angle is 90 degrees; when the circuit detunes, then the phase angle will increase (capacitive detuning) or decrease (inductive detuning) and the phase detector will resp. sent a logic "1" or "0" to the CCS. Via the PWM, the CCS corrects the frequency of the carrier wave up or down in 4Hz steps until the circuit is in resonance again. Because of this principle the carrier frequency is not fixed at 4kHz but lies between 3500 and 4250Hz.

The MF-output circuit has a constant current nature up to 750 Ohms. Above this impedance, the behaviour is more of a constant voltage nature.

The watchdog circuit is clocked by the CCS at the end of each program run (every 10ms). In a situation where there is no clock signal, e.g. because of a fault in the program memory, the watchdog circuit will switch off the US- and MF-outputs and sends an error message to the CCS. This results in an error handling routine (reducing output power and putting error message on display). However, note that in case of a serious software fault the CCS may not be able anymore to perform this routine.

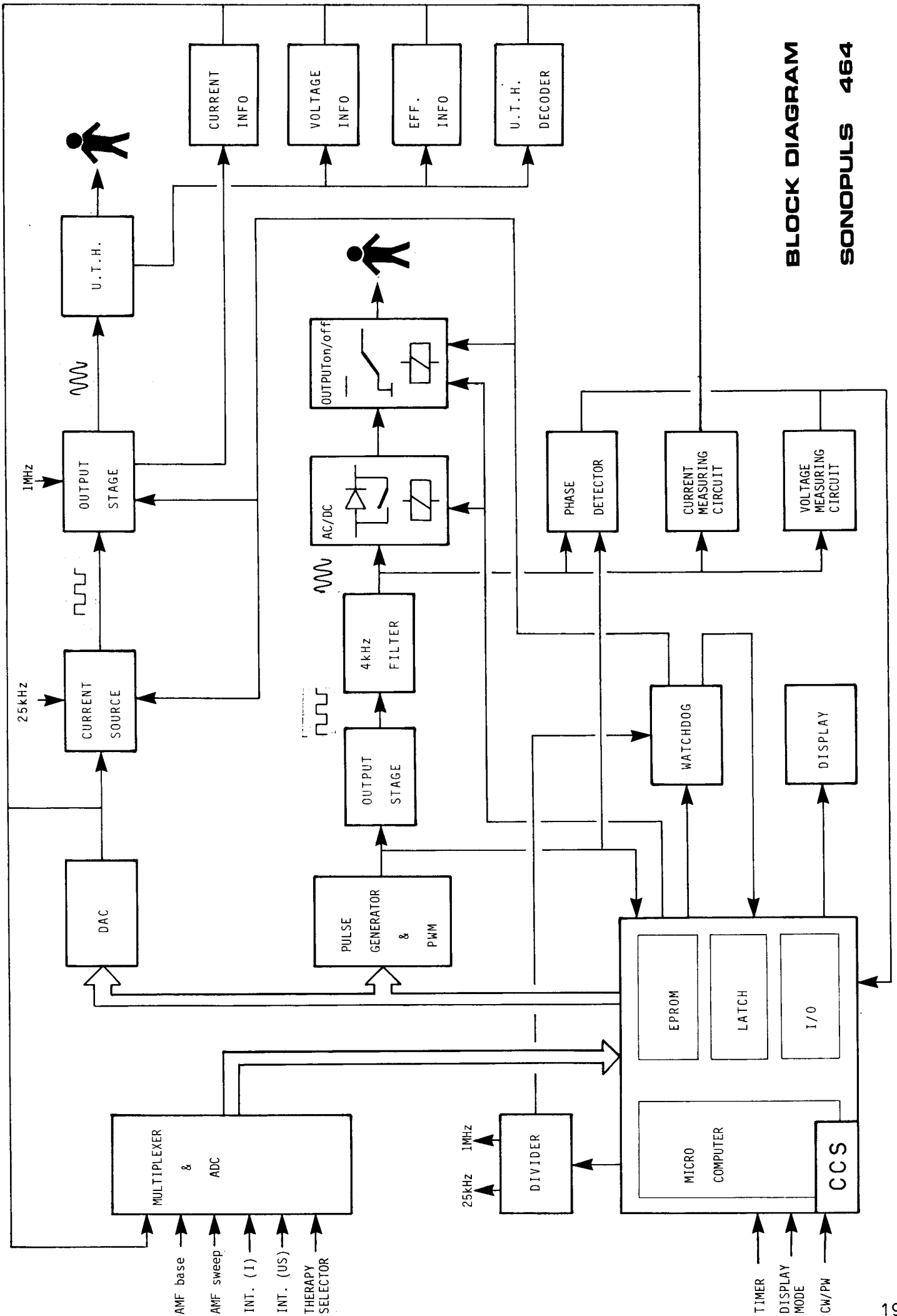

BLOCK DIAGRAM
SONOPULS 464

NOTES

A large grid of graph paper for taking notes, consisting of approximately 25 columns and 35 rows of small squares.

CIRCUIT DESCRIPTION

Power supply

The battery charging current flows from the positive pin of Socket 1 via L1, D1040, battery BA1, T1017, P1006, L1 back to the negative pole. The max. permissible charging current for the battery is 400mA. With T1019 and T1017, the current is limited automatically to this value. Working: when the current becomes more than 400mA, the voltage drop over P1006 increases and T1019 becomes more conductive, T1017 becomes less conductive so that the charging current is reduced.

Germanium diode D1040 is a protection against battery chargers with reversed polarity. LE1001 lights as soon as the battery charger is connected. When the unit is battery operated, the battery current flows via F1001, ON/OFF switch S1, via the circuitry of the Sonopuls 464 to ground and via D1034 back to the negative pole of the battery.

The 12V supply voltage feeds both the US- and MF-output stages and voltage regulator IC1021 which serves a 5V supply voltage for the integrated circuits.

Central Control Section (CCS)

The microcomputer (uCOM) IC1019 controls all sequences which are necessary for the function of the SONOPULS 464. The necessary instructions for the uCOM are stored in the program memory IC1018, an 32 kbyte EPROM. These instructions initiate, for example, the following sequences:

- Execution of an internal test of the instrument directly after the unit is switched on.
- Execution of suitable measures if an error is detected (reducing output power and putting error message on display).
- Permanent, cyclic interrogation of the controls (mode selector, US-intensity control, base AMF, etc.).
- Permanent, cyclic interrogation of the monitoring signals from the US- and MF-outputs.
- Controlling the Analog to Digital Conversion of these signals.
- Decision as to whether these values exceed specific error limits and, if applicable, initiation of an error handling routine.
- Controlling the Digital to Analog Conversion.
- Output of control signals to the display, the LED's, and the buzzer.
- Permanent internal monitoring by triggering and interrogating the watchdog circuit.

Functions of the uCOM terminals

AD0...AD7

These lines are used in multiplex mode, either as an 8 bit data input port or as an 8 bit address output port.

A8...A15

This is an 8 bit address output port. Together with AD0...AD7 it is possible to make up a 16 bit address for the program memory.

P1.0, P1.7, P3.5

The uCOM interrogates the positions of the switches on the control panel via these inputs.

P1.1

During the internal test, the functioning of the watchdog circuit is tested via this input (first transition from 0 to 1, then after resetting the watchdog, a second transition from 1 to 0). During normal operation, input 1.1 is 1. In case of a fault in the CCS (or watchdog circuit), the watchdog circuit is no longer triggered (reset) and input 1.1 becomes 0. This results in an error handling routine (error message on display (...)). For safety reasons, both the US- and MF-outputs will be blocked by hardware.

P1.2

During the internal test, the functioning of the voltage measuring circuit (clip detector) is tested via this input (transition from 0 to 1). When during normal operation this input becomes 1, then the CCS reduces the duty cycle of the drive signal resulting in decrement of the output voltage.

P1.3

This input is normally connected to ground via jumper ST4 and R1079. When the jumper is removed then the unit will switch to the test mode and the test routines can be called with the aid of the time setting switch.

P1.4

Input for the phase detector feedback signal. When the input is 0 then the CCS increases the carrier frequency, when the input is 1 then the frequency is reduced.

P1.5

Via this input the CCS receives the End Of Conversion pulse generated by the ADC at the end of each conversion cycle.

P1.6

Output for test equipment (not for service purposes).

P3.4

Monitor input. During the internal test, the functioning of the PWM is tested via this input. The NAND-gate IC1012-IV operates as a switch for the 250kHz signal at its input pin 12. The gate is controlled by the PWM output. The 250kHz clock signal will pass the gate for as long as the PWM output is 1. By counting the number of clockpulses entering input 3.4, the CCS can exactly computerize the pulse duration of the PWM output.

X-tal 1, 2

Connections for external crystal for clock generator.

RST (Reset)

Input for power-up reset capacitor.

ALE (Address Latch Enable)

Control output for the EPROM address buffer. The address byte A0...A7 is written into the latch IC1030 with the negative going edge of the ALE signal.

PSEN

Via the Program Store Enable output, the uCom commands the program memory IC1018 to put the contents of the currently addressed memory location on the data bus (00...07). PSEN is active only when the uCOM is reading command bytes.

RD, WR

Via these output lines the uCOM indicates to the ADC, pulse generator/PWM, bus buffer (IC1029) and latch (IC1032) if it wants to read (RD = 0) or write (WR = 0) data.

EA (External Access enable)

When held at logic 0 state, the uCOM fetches all instructions from external program memory.

RXD, TXD

These are resp. serial data in- and output ports (not for service purposes).

INT0

The 100Hz clock frequency at this interrupt input is used as an external timing reference for the CCS.

INT1

Via this interrupt input, the uCOM monitors the output of the pulse generator/PWM.

Program memory (IC1018)

The 32kbyte EPROM contains the complete operating system of the SONOPULS 464 and the test routines for testing and service purposes. Each of the 32,768 memory locations contains one instruction byte (word) of the complete program. The memory locations can be addressed by the uCOM via a 15 bit address bus (A0...A14).

The contents of the selected memory location appears at the EPROM outputs 00...07 as soon as input OE is 0. The 8 bit data word is then read by the uCOM via the data bus and decoded. The uCOM then initiates the actions corresponding to the instruction.

Address buffer (IC1030)

The lower 8 bits of the address issued by the uCOM are buffered in latch IC1030. When the Latch Control input (LE) is 1, then the latch is transparent, i.e. the outputs A0...A7 follow the inputs D0...D7, when this level switches to '0', the data word present at this time is stored. The outputs are independent of the inputs for as long as LE is '0'. The inputs of the latch are connected to port AD0...AD7 of the uCOM, which generates either data or addresses (multiplex mode). If the port has an address (indicated by the uCOM by the '1' to '0' transition of the ALE signal), then this is transferred to the address buffer so that the port is available for the transfer of other data to and from the uCOM.

Bus buffer (IC1029)

With the aid of the bus buffer, the fan-out of the uCOM outputs AD0...AD7 is enlarged. The 74HCT245 is a bi-directional buffer: when input DIR = 0 the buffer sends data from the ADC to the uCOM, when DIR = 1 data is sent from the uCOM to the pulse generator/PWM or to one of the latches. Input DIR is controlled by the uCOM's RD signal.

With the Gate (G) input at logic low level, the buffer is set in normal mode (G = 1 = tri-state mode).

Latches IC1013, IC1014, IC1016 and IC1017

These latches are used as I/O ports for the CCS, they are connected to the AD output port of the uCOM. In the short time that data is available at this port, this data is stored in one of the latches.

The 74HC374 contains eight D-type flip-flops with tri-state outputs. The data at the D-inputs is loaded into their respective flip-flops on the next positive-going transition of the clock. When the Output Control (OC) is at logic low level, the latch is set in normal mode (OC = 1 = high impedance state).

IC1013 This latch forms part of the DAC for the US-output.

IC1014 Output O0 is a control line for the US-output circuit (see circuit description current source US-output); output O1 drives the fail-safe indicator LE1004; output O2 drives the buzzer; outputs O3 O4 and O5 drive the display mode indicators LE1003, LE1001 and LE1002; output O6 drives the contact control indicators LE6001 and LE6002; output O7 is a control line for selecting the suitable sensitivity range for the UTH current information circuit.

IC1016 The outputs of this latch are connected to several circuit sections which are under control of the CCS; output O0 supplies the reset pulse for the watchdog circuit; output O1 drives T1015 in the MF-current measuring circuit (for discharging C1030); output O2 drives T1016 for activating relay RE1002 (AC/DC switch); output O3 activates, via AND-gate IC1028-III and T1014, relay RE1001 (MF-output ON/OFF); output O4 is an output enable control line for the US-output; when output O5 = 1 the battery indicator (LE1005) gives green light, output O6 = 1 the battery indicator gives red light, output O7 = 0: watchdog flip-flop is set.

IC1017 The outputs of this latch are connected to several circuit sections which are under control of the CCS. Outputs O0, O1 and O2 are used as address lines for multiplexer IC1022; Output O3 is an enable control line for the remote control unit (1 = off, 0 = on); when output O4 = 1 the left decimal point on the display goes on; when O5 = 1 the right decimal point on the display goes on; with outputs O6 and O7 and uCOM's inputs P3.5 and P1.7 the positions are read of switches S3-I and S3-II (display mode selector and time setting switch) are read.

Address decoder (IC1032)

The 74HC138 is a 3-to-8-line address decoder. Depending on one active-low (G1) and two active-high (G2a, G2b) enable inputs, the address at the three binary select inputs A, B and C is decoded to one of eight lines. With G1 = 1 and G2b = 0, the addressed output line becomes 0 when G2a = 0. When G2a = 1 all output lines are 1.

Analog to Digital Converter (IC1008)

The ADC is of a multiplexing type with 8 input channels of which each one can be selected at any time with the aid of the multiplexer address inputs A0, A1, A2.

The uCom generates a suitable bit pattern on the address lines A0, A1, A2. A first low-high-low transition on the ALE/START inputs stores the MUX address into the ADC, a second transition resets the converter counter register to zero and starts the conversion of the analog value on the input channel selected, into a digital value (starts the converter counter). The end of conversion is indicated by a low-high transition at output EOC (End Of Conversion) and is reported to input port P1.5 of the uCom. The uCom now sends the read signal (RD = 0) and the address (A4 = 0) to NOR-gate IC1024-IV so that input OE (output enable) of the ADC becomes 1. The digital value corresponding to the analog value is now available at outputs 00...07 and can be read by the uCom (via the bus buffer).

The ADC operates on a clock frequency of 1MHz and a reference voltage of +5V (inputs Vref+, Vref-).

Multiplexer (IC1022)

To create sufficient input channels, the ADC is used in combination with an external multiplexer.

Selection of the required input channel is done by the CCS by generating a suitable bit pattern on the multiplexer address inputs A0, A1, A2 (and by addressing input IN2 of the ADC). With input E (Enable) = 0 the selected input channel is "on".

Digital to Analog Converter

The DAC is composed of IC1013, an 8-bit latch, and resistor arrays RA1001 and RA1002 which are wired as a R/2R resistor network.

The 74HC374 contains eight D-type flip flops with tri-state outputs. The data at the D-inputs are loaded into their respective flip flops on the next positive-going transition of the clock. When the Output Control (OC) is at logic low level, the latch is set in normal mode (OC = 1 = high impedance state).

With the digital value, generated by the CCS, at the data inputs D0...D7 of the latch, the output voltage of the DAC can be controlled in 10mV steps from 0 to 2.55 volt.

Oscillator and divider

Via a buffer stage (IC1020-I), the 8 MHz signal generated by the uCom, is fed to IC1009, a 12-stage binary counter. On outputs O0, O2, O3, O4, O11 this results in frequencies of resp. 4MHz, 1MHz, 500kHz, 250kHz, 1953Hz.

The 500kHz is further divided by 10 (BCD-counter IC1011-I) and by 2 (D-type flip flop IC1015-II) resulting in a 25kHz signal which is used as a switching signal for the ultrasound output stage.

On outputs O1 and O3 of BCD counter IC1011-II, the 1953Hz signal is resp. divided by 5 (391Hz) and by 10 (195,3Hz). The 391Hz signal serves as a clock signal for the watchdog circuit. The 195,3Hz signal is further divided by 2 (98Hz) and by 4 (49Hz); the 98Hz is used as an external timing reference for the uCom and the 49Hz signal, with 50% duty cycle, is applied to the PHASE inputs of the display drivers and the back plane of the display element.

Watchdog

The watchdog circuit comprises a binary up counter (IC1002-I) and a flip flop composed of the NOR-gates IC1024-I and II. The binary counter is continuously clocked by a 391Hz signal. In the normal condition, the binary counter is reset by the CCS after each program run, i.e. after every 10ms. This means that the counter is reset before output O3 can reach the logic 1 state. In a situation where there is no reset pulse (e.g. fault in program memory) output O3 becomes 1, flip flop IC1024-I, II is set and via NOR-gate IC1024-III and AND-gates IC1028-II, III, both the US- and MF-output stages are switched off. Also, via EXOR IC1025-I, this situation is reported to the uCom (port P1.1) resulting in an error handling routine (error message on display). However, note that in case of a serious fault, the CCS may not be able anymore to perform this routine.

Current source (US-output)

The current source is of a switched type and comprises IC1003-I, IC1006-II, IC1006-I, together forming a pulse width modulator, and bootstrap T1009, T1010. The bootstrap, which is the actual current source, is driven by the pulse width modulator with a 25kHz signal of which the pulse duration (duty cycle) is decisive for the intensity of the UTH supply current.

Working: The 25kHz square wave from the frequency divider circuit is integrated by RA1003(2-15)/C1008 and connected to the inverting input (-) of comparator IC1006-II. The DC voltage from the DAC (which level is proportional to the set value of the US-intensity) is connected via differential amplifier IC1003-I to the comparator's non-inverting input (+). At the comparator output this results in a 25kHz signal of which the pulse duration (duty cycle) is proportional to the DC-voltage level at the non-inverting input (+).

RA1003(3-14)/C1010 is a smoothing filter for the 25kHz ripple voltage introduced by the negative feedback from IC1004 via IC1003-I.

In the normal operating mode, the comparators IC1003-II, IC1006-III, IC1006-IV (with open collector output) are in high impedance state so that the inverting input of buffer IC1006-I follows the output of comparator IC1006-II.

The moment that the output of buffer IC1006-I is at logic 1 state (TP19 = 1), T1009 conducts, T1010 blocks and C1020 gets charged. When TP19 = 0, T1009 blocks and T1010 conducts because the capacitor charge of C1020 now helps to make the gate of T1010 positive with respect to the source. At the output of the current source, the signal is again in phase with the signal from IC1006-II.

The current source also includes a fail-safe device which is composed of the comparators IC1003-II, IC1006-III, IC1006-IV. In a fault condition, one of the three comparator outputs will switch to logic low level, as a result TP19 = 1, the 25kHz switching signal is blocked and the current source is disabled.

In case of a software fault, the current source is disabled by the watchdog via AND-gate IC1028-II and comparator IC1003-II.

When the max. permissible current in the output stage is exceeded then IC1006-III switches to low output state and the current source is blocked.

Comparator IC1006-IV is a safety device for T1010. In a fault condition, when there is no switching signal from IC1006-II, the transistors in the current source (bootstrap) are driven by the 25kHz spikes from IC1006-IV. When there would be no drive signal at all, C1020 would discharge and T1010 would blow as the transistor is then driven in its linear range.

In the normal condition, the 25kHz spikes from IC1006-IV do not interfere with the 25kHz switching signal from IC1006-II.

US-Output stage

The frequency of the UTH supply current is 1MHz. This frequency is adapted from 12-stage binary counter IC1009, and connected to inputs I0...I3 of "low to high level" converter IC1010. When OE = 1 (Output Enable), this results in a 1MHz square wave of 12V (tt) at outputs O0...O3 and /O0.../O3 so that, via driver stages T1004/T1006 and T1003/T1005 alternately T1001 and T1002 are driven.

The supply current from smoothing filter D1012/L1005/C1006 is thus alternately routed from the centre tab of TR1003 via D1001, T1001, to R1002...R1009, or via D1002, T1002 to R1002...R1009.

With L1003/C1003/C1004/C1005 the output stage is made resonant for 1MHz so that in the secondary winding of TR1003, a sinusoidal current results with an amplitude proportional to the duty cycle of the 25kHz signal from the current source. This current serves as supply current for the UTH.

The circuit of L1001, R1001 and C1002 acts as a filter for switching transients from T1004 and T1005.

When the output stage is unloaded, L1002 takes care for sufficient detuning to keep the voltage amplification in the output stage to a minimum.

UTH voltage information (U-info)

The voltage from the UTH, which indicates the acoustic loading, is smoothed by L1008, C1015, R1022 and buffered by IC1002-II. Diodes D1010 and D1005 are protective diodes. The circuit is calibrated with the aid of a dummy load and P1004 (see circuit adjustments). The voltage that results at TP9 is connected, via the ADC, to the CCS. With the aid of this signal, the CCS updates the display (US-intensity/US-power) and monitors the level of acoustical contact.

UTH current information (Iinfo)

The output current to the ultrasound treatment head flows through the primary winding of TR1001. The current, induced in the secondary winding is double phase rectified by D1006...D1009 and flows through R1021, P1003 and P1002. The voltage drop across the resistors is proportional with the amplitude of the UTH supply current. This voltage is smoothed by D1005, C1016 and R1018, and buffered by IC1001-I. D1003 is a protection diode. The voltage that results at TP3, is connected, via the ADC, to the CCS for monitoring and any necessary correction.

With T1008, the sensitivity of the measuring circuit can be adapted to the level of drive current; T1008 conducts when the large treatment head is connected, and blocks when the small head is used.

Efficiency information (C-value)

The value of trimmer potentiometer Pcal in the treatment head represents the efficiency factor of the X-tal. Pcal is set at the works. The CCS measures this resistance value via resistor network (R1063, R1064) and the ADC and can thus match the electrical output power (UTH supply current) to the UTH efficiency. This means that heads with various efficiency factors can be connected to the unit without recalibration.

UTH decoder

In the plug of each treatment head there is a resistor of which the value is related to the type of UTH. There are two resistor values for the two different types of treatment heads:

1MHz, large: 0 Ohm

1MHz, small: 392 Ohm

This resistance value is converted into an analog voltage by resistor network R1062/R1061. Via the ADC, the CCS can detect which type of head is connected and set the output power accordingly. Also the CCS can detect if illegal heads, such as the 3MHz types for the Sonopuls 434, are connected, when this is the case, the CCS will block all functions of the Sonopuls 464.

Pulse generator & Pulse Width Modulator (IC1027)

The 82C54 is a programmable interval timer/counter comprising three presetable down counters which are fully independent and can operate in different modes. Each counter is programmed by the CCS by writing a Control Word and then an initial count on data inputs D0...D7. The Control Word is stored in the internal Control Word Register when A0, A1 = 1, and determines how the counter selected operates (mode selection). For the initial count, inputs A0, A1 are used to select the counter to be written into.

Counter 1 operates as a divide-by-N counter for the 4MHz clock at input CP1. N depends on the initial count, written by the CCS into the counter (an initial count of N results in a square wave with a period of N clock cycles). By changing the value of the initial count, the CCS controls the frequency at OUT1. This frequency functions as carrier wave frequency and lies between 3500 and 4250Hz (further referred to as a 4kHz signal), with a duty cycle of 50%. OUT1 is monitored by the CCS via buffer stage IC1020-II.

OUT1 connects to GATE0 and GATE2 of counters 0 and 2. GATE = 1 enables counting; GATE = 0 disables counting.

Counter 0 operates as retriggerable one shot. A low-high transition (trigger) on GATE0 results in loading the counter (initial count) and setting OUT0 low on the next clock pulse, thus starting the one-shot pulse (an initial count of N will result in a one shot-pulse N clock cycles in duration).

By changing the value of the initial count, the CCS varies the pulse duration (duty cycle) of OUT0. At the output of buffer/inverter IC1020-III this results in a signal with a duty cycle that lies between 0 and 50% (50% results in maximum output current). Because the counter is triggered by the 4kHz of OUT1, the frequency of OUT0 is also 4kHz.

The output of inverter IC1020-III is monitored by the CCS via NAND-gate IC1012-IV.

The operation of Counter 2 is identical to Counter 0 except for the initial count which is half the initial count of Counter 0. The time that OUT2 = 0 is therefore half the time that OUT0 = 0. This 4kHz output signal serves as clock signal for the Phase Detector Circuit (see corresponding circuit description).

MF-output stage, 4kHz filter, AC/DC selector, Output ON/OFF circuit

The pulse duration (duty cycle) of the 4kHz signal at the output of buffer IC1020-III is decisive for the intensity of the output current. This signal is connected via NAND-gate IC1012-III to bootstrap T1011, T1012, T1013. Via the NAND-gate, the state of these transistors is defined during power-up by the reset circuit C1041, R1054, D1030. At the output of the bootstrap, which functions as a current source, the signal is again in phase with buffer output IC1020-III and fed to 4kHz filter L1006/C1026 from which a 4kHz sinusoidal current results.

The 4kHz sine wave is fed via current transformer TR1003 and 27.12 MHz filter C1027, L1007, C1028 to rectifier diode D1041. Depending on the selected therapy form, the current is routed to the patient via D1041 or via relay contact RE1002-I, resulting in resp. a (MF) direct current or a (MF) alternating current. The output-on/off circuit (RE1001) is controlled by the CCS but can be overruled by the watchdog circuit in case the treatment time has elapsed or in case of a fault.

Phase detector

The phase detector comprises comparator IC1005 and D-type flip flop IC1015-I. The comparator operates as zero-crossing detector for the sinusoidal (MF) output current; the comparator output synchronously changes state with the zero crossings of the sinusoidal output current but with 180 degrees phase shift.

This square wave is connected to input D (data) of flip flop IC1015-I. The flip flop reads the logic state of the D-input after a low-high transition of the clock pulse (from IC1027-OUT2). When the output circuit is exactly in resonance there is 90 degrees phase shift between the 4kHz signal of IC1027-OUT0 and the sinusoidal output current (patient current). The low-high transition of the clock then falls together with the high-low transition of the square wave at input D. In practice however, there will always be a small phase shift between the two signals so that at the time of the clock pulse, the flip flop either reads a logic 1 or 0 at input D. When D = 0, Out O = 0 resulting in increment of the (carrier) frequency; when D = 1, Out O = 1 resulting in decrement of the frequency. It is concluded from this that during normal operation of the unit, the output of the phase detector continuously switches from 0 to 1 and vice versa and that the carrier frequency is never steady but always varies up and/or down in 4Hz steps.

Voltage monitoring circuit (MF-output)

The output circuit is protected against over-voltage both by hardware and software. The output voltage is limited at 75V (top) by zener diodes D1015, D1016. When the diodes are clipping, T1018 is driven, input (pin 9) of inverter/buffer IC1020-IV = 0 so the output (TP21) = 1. This logic 1 is reported to the CCS which initiates the following action: reducing the duty cycle of the 4kHz drive signal. This results in decrement of the output current and voltage until the buffer output = 0.

Current measuring circuit (MF-output)

The voltage induced in the secondary winding of TR1003 is proportional to the amplitude of the patient current. TR1003 connects to single-phase rectifier IC1007-I. Because of D1026, the circuit functions as a peak picker; the charging current of C1030 is proportional to the peak value of the patient current. At the output of buffer IC1007-II (TP16) this results in a voltage which is inversely proportional with the peak value of the patient current; when the output current is 0mA, the voltage at TP16 is at max. (5V). C1030 is periodically discharged by the CCS with the aid of T1015. The resulting output voltage is feedback to the CCS via the ADC for monitoring and any necessary correction.

CARRIER FREQUENCY CORRECT (output circuit in resonance)

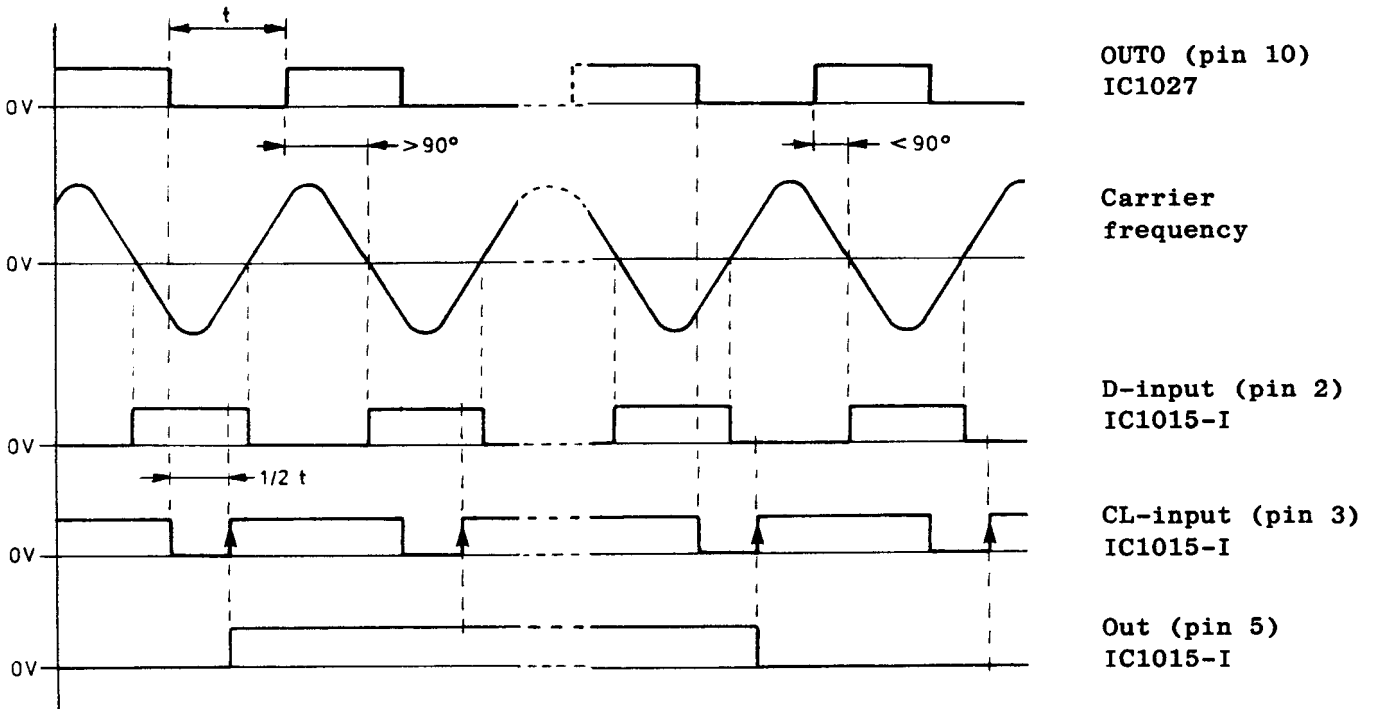
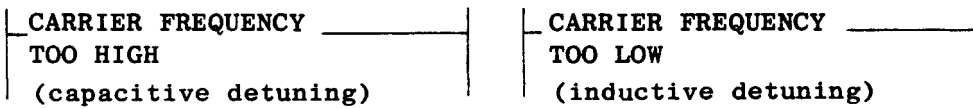
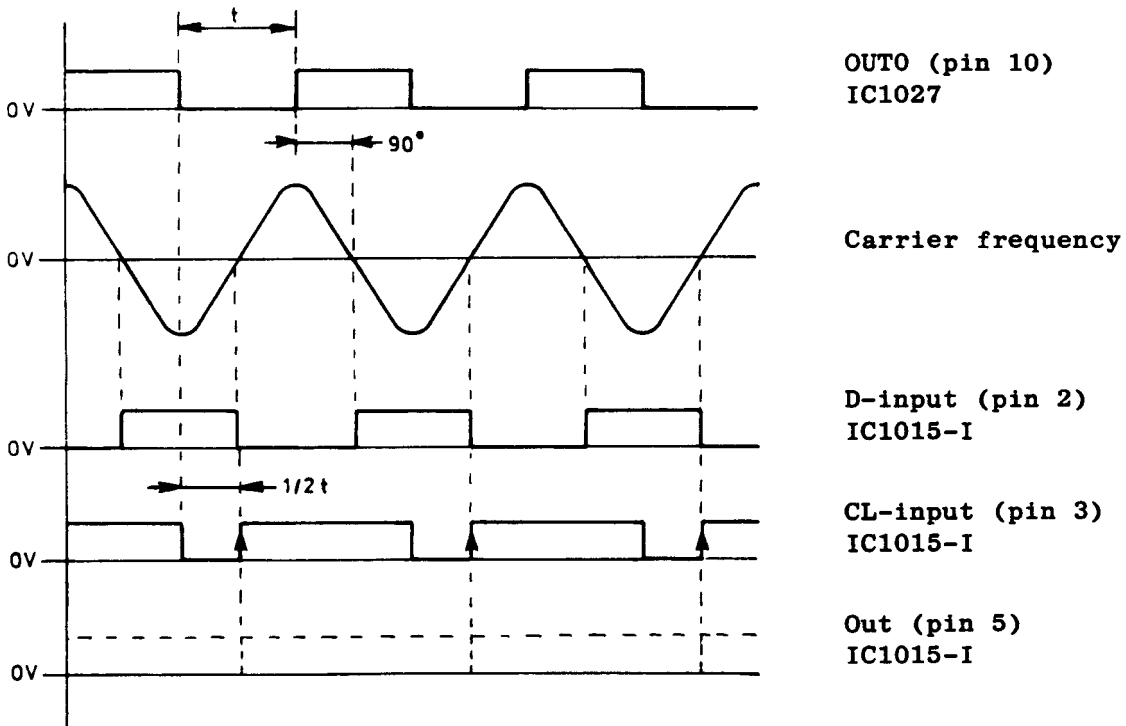

MODIFICATIONS

Modifications series 2

To improve the puls-shape in the pulsed ultrasound mode (especially for low intensity settings) the following modifications have been executed:

Deleted components:

R1014 100k
R1023 1k21

New inserted components:

C1083 33n
R1023 4k75
R1085 2k7
R1089 100k

Software:

Version 6.1 DELETED
Version 6.3 NEW

NOTE:

The new software version 6.3 also includes the old 6.1 program. By reading the value of R1023, the uCOM knows which software is to be applied:

R1023 = 1k21 (series 1 units): old version

R1023 = 4k75 (units from series 2): new version

By doing so, the new EPROM (version 6.3) can also be used for series 1 units.

Also deleted:

R1052 182E

Modifications series 4

To comply with the German TuV safety standards (shielding of housing free of ground potential and radio-interference suppression) the following modifications have been executed.

Deleted components:

R1 330E

New inserted components:

C1081 1n/3kV
C1082 1n/3kV
C1084 220p
C1085 220p
C1086 2n2
C1087 1n/3kV
C1088 1n/3kV
CN10 PCB connector
CN11 PCB connector
L2 Coil
L3 Coil
R1086 1n/3kV
R1087 1n/3kV
R1088 1n/3kV

WARNINGS

According to safety regulations it is not allowed to use any other battery charger than the type prescribed. Other adaptors may not meet the requirements of approvals and safety standards and may even damage the battery or the equipment.

Any adjustment, maintenance and/or repair should be carried out by a SKILLED QUALIFIED PERSON.

According to approvals and safety standards, always use original components if, for any reason, the unit has to be repaired.

HOW TO OPEN THE UNIT

Remove the six cross-slotted screws at the bottom side (save the washers) and take off the upper part. For reassembly: mount the two short screws (10mm) at the rear side.

MEASURING INSTRUMENTS

The following equipment is necessary for calibration and functional tests of the Sonopuls 464:

- Multimeter (rms)
- Dummy load for circuit adjustments (for ordering data see spare parts list)
- Acoustical load (for ordering data see spare parts list)
- Safety tester (earth leakage tester)
- Bounding tester (6V unloaded, 25A shortened)

Special tool:

- Key wrench for treatment head (for ordering data see spare parts list)

FAULT CONDITIONS

In case of a fault, test programmes can be used to test the circuit sections of the Sonopuls 464. See chapter "Test routines".

Display blanks (internal test not passed)

Possible cause: no supply voltage or uCOM start-up failure:

- a) Check +5V supply voltage for uCOM, latch (IC1020) and EPROM.
- b) Check 8MHz clock signal of uCOM (TP5)
- c) Check power-up reset capacitor C1078 of uCOM.
- d) Replace uCOM, latch (IC1030) and/or EPROM.

Fault indication on display (..)

In case of a fault indication on the display (display shows two dots) leave the unit switched on and call for the 'TEST MODE' (remove the test jumper ST4). The first 'TEST ROUTINE' is then automatically called. This is routine '0'. In this routine, several circuit sections are tested by the computer. The result of the test is shown by means of a number flashing on the display. The number indicates in which circuit section the computer has detected a fault. See list below.

"0 " No fault
No fault detected by the computer.

"01" Watchdog
Fault in watchdog circuit.

Possible defects	Advised test routines
IC1002-I	test 5
IC1016 (latch)	test 5
IC1025-I	

"02" ADC
Fault in Analog to Digital Converter.
The ADC is tested during the internal test as follows:
The voltage at the ADC input channel IN0 (contact control threshold level) is read and converted into a digital value. The test is passed when the converted value corresponds with a reference value stored in the program memory, otherwise fault number 02 is displayed.

Possible defects	Advised test routines
IC1008	test 4
R1023	
RA1004	

- "03" DAC
 Fault in Digital to Analog Converter.
- | | |
|-------------------|-----------------------|
| Possible defects | Advised test routines |
| IC1013 | test 1 |
| RA1001 | |
| RA1002 | |
| IC1032 (latch) | |
| IC1022 (multipl.) | |
| IC1008 (ADC) | test 25 |
- "04" US-intensity control (instable set value)
 Instable set value for ultrasound intensity.
- | | |
|------------------|-----------------------|
| Possible defects | Advised test routines |
| P1007 | test 10 |
| IC1008 (ADC) | test 4 |
- "06" Iinfo UTH
 Fault in treatment head current information circuit.
 During the internal test this circuit section is tested by reading the voltage at multiplexer input I5 with non active output stage. If the result is 0 (zero) then the test is passed, otherwise fault number 06 is displayed.
- | | |
|-------------------|-----------------------|
| Possible defects | Advised test routines |
| IC1001-I | test 2 and/or 3 |
| IC1022 (multipl.) | |
- "07" Uinfo UTH
 Fault in treatment head voltage information circuit.
 During the internal test this circuit section is tested by reading the voltage at multiplexer input I7 with non active output stage. If the result is 0 (zero) then the test is passed, otherwise fault number 07 is displayed.
- | | |
|-------------------|-----------------------|
| Possible defects | Advised test routines |
| IC1001-II | test 2 and/or 3 |
| IC1022 (multipl.) | |
- "08" UTH detection
 Fault in circuit for ultrasound treatment head detection.
 Illegal voltage at multiplexer input channel I2.
- | | |
|-------------------|-----------------------|
| Possible defects | Advised test routines |
| IC1022 (multipl.) | test 26 |

- "09" US output stage
 Fault in ultrasound output stage or in current measuring circuit
 (Iinfo)
- | | |
|------------------|-----------------------|
| Possible defects | Advised test routines |
| | test 2 and/or 3 |
-
- "10" T1008
 Fault in circuit for selecting large/small UTH current information
 potentiometer (Iinfo).
- | | |
|------------------|-----------------------|
| Possible defects | Advised test routines |
| T1008 | test 24 |
| IC1014 (latch) | test 7 |
| P1002 | |
| P1003 | |
-
- "11" EPROM
 Fault in EPROM check sum.
- | | |
|------------------|-----------------------|
| Possible defects | Advised test routines |
| IC1018 | |
-
- "12" C-value
 Fault in circuit for reading the UTH efficiency factor (C-value).
 Illegal voltage at multiplexer input channel 11.
- | | |
|------------------|-----------------------|
| Possible defects | Advised test routines |
| IC1022 | test 25 |
-
- "13" Current intensity control (illegal set value)
 Illegal set value for current intensity.
- | | |
|------------------|-----------------------|
| Possible defects | Advised test routines |
| P1008 | test 11 |
-
- "14" MF-output stage not in resonance or resonance frequency not found
- | | |
|------------------|-----------------------|
| Possible defects | Advised test routines |
| IC1005-I | test 38 |
| IC1015-I | test 38 |
| L1006 | |
| C1026 | |
| T1011 | |
| T1012 | |
| T1013 | |
| IC1020-III | |
| IC1012-III | |

"15"

PWM

Fault in Pulse Width Modulator (PWM)

The output of the PWM is monitored by the microcomputer via IC1020-II and NAND-gate IC1012-IV. The 250kHz signal at the input (pin 12) of the NAND-gate can pass the gate for as long as the PWM feedback signal is '1'. By counting the number of 255kHz clockpulses that enter the microcomputer (port 3.4) the puls duration of the feedback signal can be determined precisely. If illegal values are found, fault number 15 is displayed.

Possible defects	Advised test routines
IC1027	
IC1020-II	
IC1012-IV	

"16"

Peak picker MF-output stage

Possible defects	Advised test routines
IC1007	
T1015	
IC1016	test 5

"17"

Relay RE1002

Possible defects	Advised test routines
RE1002	test 5
T1016	test 5
IC1016	test 5

"18"

Voltage monitoring circuit MF-output stage

This circuit section is tested during the internal test. The microcomputer did not received a feedback signal from the monitoring circuit.

Possible defects	Advised test routines
D1015	
D1016	
T1018	
IC1020-IV	

"19"

Current intensity control (instable set value)

Instable set value for current intensity.

Possible defects	Advised test routines
P1008	test 11

"20"

External timing reference (97.7Hz)

Possible defects	Advised test routines
IC1002-II	

TEST ROUTINES

The test routines stored in the program memory of the Sonopuls 464 are used for service purposes. Access to these routines is obtained by removing the jumper ST4 when the unit is switched on. Test 0 is always called as the first test program. Pressing the time setting switch to 'UP' increments the program number by 1; pressing the switch to 'DOWN' decrements the program number by 1. The number of the selected test appears for two seconds on the display, then the buzzer sounds and the test is ready for use. Any test result will appear on the display.

Test 0: Internal test

In this routine, several circuit sections are tested by the computer. The result of the test is shown by means of a number, flashing on the display. The number indicates in which circuit section the computer has detected a fault. See list below (see also previous chapter "Fault indication on display").

Number	Fault in
0	No fault detected by the computer
01	Watchdog circuit
02	Analog to Digital Converter
03	Digital to Analog converter
04	US-intensity control (instable set value)
06	UTH current measuring circuit
07	UTH voltage measuring circuit
08	UTH detection
09	Ultrasound output stage
10	T1008
11	EPROM
12	Circuit for reading the efficiency factor of the UTH (C-value)
13	Current intensity control (illegal set value)
14	MF-output stage not in resonance or resonance frequency not found
15	Pulse Width Modulator (PWM)
16	Peak picker MF-output stage
17	Relay RE1001
18	Voltage monitoring circuit MF-output stage
19	Current intensity control (instable set value)
20	External timing reference (97.7 Hz)

Test 1: Check of the Digital to Analog converter (DAC)

By means of the display mode switch, one of the 8 bits at the input of the Digital to Analog Converter can be set to '1'. The number of the selected bit appears on the display. Each time the bit number is incremented (which corresponds to multiplication by 2), the voltage measured at TP14 should increase by a factor of approximately 2. With bit no. 0 selected, the output voltage of the DAC should be 10mV; with bit no. 7 selected, the output voltage should be 1.25V. During the test the output stage is inoperative.

Selected bit Voltage at TP14

no. 0	0.01V
1	0.02V
2	0.04V
3	0.08V
4	0.16V
5	0.31V
6	0.62V
7	1.25V

Test 2: Activates the output stage in low power mode (PW)

Connect a treatment head to the Sonopuls 464. The output stage is then driven by the Digital to Analog Converter (DAC) with a square wave voltage (pulse duration: 2ms, pulse interval: 8ms) of constant amplitude (decimal input value of DAC is 20).

With the aid of this test, various control and feedback signals of the output stage can be measured, for example, the voltage at TP3, which is proportional to the UTH current, and the voltage at TP9, which is proportional to the acoustic loading of the UTH. These signals should be square wave voltages with a pulse duration of 2ms and a pulse interval of 8ms. The amplitudes are undefined.

Test 3: Activates the output stage in low power mode (CW)

The output stage is driven by the Digital to Analog Converter (DAC) with a voltage of constant amplitude (continuous wave; decimal input value of DAC is 20). It is not necessary to connect a treatment head to the Sonopuls.

With the aid of this test, various control and feedback signals of the output stage can be measured

The voltage from the UTH current information circuit is shown on the display (in volts).

Test 4: Check of the Analog to Digital Converter (ADC)

The ADC can be tested with the aid of the US-intensity control P1007. When the intensity control is turned from minimum to maximum, the ADC converts the analog voltage levels at the centre tab of the potentiometer (0 - 5V) into digital values (0 - 255, with a tolerance of 35 values).

If there are more than 220 different levels passed, the ADC operates correctly and the display shows '1'. Otherwise, '0' is displayed.

To test the ADC proceed as follows:

Turn the US-intensity control P1007 fully anti-clockwise and wait till the display shows '0'. Then turn the intensity control slowly to the fully clockwise position. Read the display:

'1' means test passed

'0' means test not passed

(the test can be restarted by turning the intensity control fully anti-clockwise).

Test 5: Test of latch IC1016

By means of the display mode switch, one of the 8 outputs of latch IC1016 can be set to '1'.

Working: pressing the display mode switch to the right (W) increments the number of the output by 1; pressing the display mode switch to the left (min) decrements the number of the output by 1.

The number of the selected output appears on the display.

The selected output switches from '0' to '1' with a frequency of 1Hz (except output 00, watchdog reset). The other outputs remain '0' (except outputs 00 and 07).

Output selected	Result
00	Divider of watchdog circuit is reset
01	Reset transistor T1015 in the MF-current measuring circuit is put on/off
02	RE1002 is switched on/off
03	RE1001 is switched on/off
04	US-output stage disabled
05	
06	LE1005 flashes red
07	Flip-Flop of watchdog circuit is set

Important note: when output 07 is selected, the Flip-Flop of the watchdog circuit is set and, as a consequence, RE1001 drops out. Before selecting further tests we advise switching the Sonopuls off and on to reset the Flip-Flop and to energize RE1001 again. This is because some tests (34, 35 and 38) drive the MF-output stage to full power. If RE1001 is then still off, load resistor R1044 in the MF-output stage burns out.

Also note that when the watchdog flip-flop is set the US-output stage is inoperative.

Test 6: Test of latch IC1017

By means of the display mode switch, one of the outputs 00 ... 05 of latch IC1017 can be set to '1'. Outputs 06 and 07 cannot be selected; this would disable the functioning of switches S3-I and S3-II.

Working: pressing the display mode switch to the right (W) increments the number of the output by 1; pressing the display mode switch to the left (min) decrements the number of the output by 1.

The number of the selected output appears on the display.

The selected output switches from '0' to '1' with a frequency of 1Hz. The other outputs remain '0'.

Output selected	Result
00	
01	
02	
03	T1021 in the remote control input circuit is put on/off
04	DP1 flashes
05	DP2 flashes

Test 7: Test of latch IC1014

By means of the display mode switch, one of the 8 outputs of latch IC1014 can be set to '1'.

Working: pressing the display mode switch to the right (W) increments the number of the output by 1; pressing the display mode switch to the left (min) decrements the number of the output by 1.

The number of the selected output appears on the display.

The selected output switches from '0' to '1' with a frequency of 1Hz.

The other outputs remain '0'.

Output selected	Result
00	
01	LE1004 flashes
02	Buzzer sounds
03	LE1001 flashes
04	LE1002 flashes
05	LE1003 flashes
06	UTH contact indicators are flashing
07	T1008 in the UTH current measuring circuit is put on/off

Test 8: Test of ADC input IN0 (contact indication threshold level)

The ADC input channel IN0 is read and the result is displayed in volts. A value 4.0 should be displayed.

Test 9: Check of the base AMF control (P1010)

The voltage at the ADC input channel IN3 is read and the result is displayed in volts.

The displayed values should lie between 0.0 (fully anti-clockwise) and 5.0 (fully clockwise).

Test 10: Check of the ultrasound intensity control (P1007)

The voltage at the ADC input channel IN4 is read and the result is displayed in volts.

The displayed values should lie between 0.0 (fully anti-clockwise) and 5.0 (fully clockwise).

Test 11: Check of the current intensity control (P1008)

The voltage at the ADC input channel IN6 is read and the result is displayed in volts.

The displayed values should lie between 0.0 (fully anti-clockwise) and 4.7 (fully clockwise).

Test 12: Check of the sweep frequency control (P1009)

The voltage at the ADC input channel IN7 is read and the result is displayed in volts.

The displayed values should lie between 0.0 (fully anti-clockwise) and 5.0 (fully clockwise).

Test 13: Check of the ultrasound mode selector (S2)

The position of the ultrasound mode selector is read and the corresponding interval time is displayed.

Mode	Displayed value
Continuous	0
Pulsed	8 (ms)

Test 14: Check of the selector switch therapy-form (S1001)

The position of the selector switch is read and displayed by a number.

Therapy-form	Displayed number
Combined therapy with MF AC current	01
Combined therapy with MF DC current	02
Ultrasound therapy	03
Medium frequency alternating current	04
Medium frequency direct current	05

Test 15: This test is not for service purposes (reserved for production tests only)

Test 16: Check of the display mode switch (S3-I)

The position of the display mode switch is read and the corresponding display mode indicator is put on (LE1003, LE1002 or LE1001).

Test 17: Buzzer test

The buzzer is switched on and off with a frequency of 1Hz.

Test 18: Display and LED test

All display segments and LEDs are put on. The battery indicator (LE1005) flashes red/green.

Test 19: Reading the EPROM version

The version number of the EPROM is read and is displayed as follows:

6.Y

The first digit (6) is the number of the equipment (Sonopuls 464)
The second digit (Y) is the number of the software version.
The number of the software version is incremented by 1 after every software modification.

Test 20: Display test

Alternately digit 1 and digit 2 count from 0 to 9. The corresponding decimal point is also put on. The battery indicator (LE1002) lights red.

Test 21: This test is not for service purposes (reserved for production tests only)

Test 22: Measurement of the battery voltage

The ADC input channel IN3 is read and the value is computed to the battery voltage. The result is shown on the display in volts.

Note: the most significant digit is in this test indicated by the display mode LEDs:

0 LEDs on: read 0 (-.-)

1 LED on: read 1 (-.-)

The value between the brackets (-.-) is the value shown on the display.

Test 23: Measurement of the battery voltage

This test is identical to test 22 but includes extra software to facilitate production tests (not relevant for service purposes).

Test 24: Test of transistor T1008 (selection of UTH large/small)

Connect a treatment head to the Sonopuls 464. The output stage is then driven by the Digital to Analog Converter with a square wave voltage of constant amplitude (decimal input value of DAC is 20). T1008 is now switched on and off with a frequency of 1Hz. Each time the transistor changes state, the displayed value must change by a factor of at least 2. The displayed values are the amplitudes of the measured voltage at TP3 (in volts) which is proportional to the UTH current.

Test 25: Test of Multiplexer IC1022 input I1 (UTH efficiency information)

The Multiplexer (IC1022) input channel I1 is read and the result is displayed in volts.

Condition	Displayed value
No UTH connected	5.0
Strap ST2 bridged	0.0
UTH connected	less than 2.6
Dummy load connected	more than 2.6

Test 26: Test of Multiplexer input I2 (UTH detection)

The Multiplexer input channel I2 is read and the result is displayed in volts.

Condition	Displayed value
No UTH connected	5.0
Strap ST1 bridged	0.0
Large UTH connected	0.0 or 0.1
Small UTH connected	1.3 to 1.5
Dummy load connected	3.4 to 3.6

Test 27: Test of Multiplexer input I4 (supply voltage remote control)

The Multiplexer input channel I4 is read and the result is displayed in volts.

Condition	Displayed value
Remote control out	5.0
Remote control in	4.2 or 4.3

Test 28: Test of Multiplexer input I6 (remote control input)

The Multiplexer input channel I6 is read and the result is displayed in volts.

Condition	Displayed value
Remote control out	5.0
Remote control in (max. intensity)	4.2 or 4.3
Remote control in (min. intensity)	0.0

Test 29: Test of Multiplexer input I5 (UTH voltage information)

The Multiplexer input channel I5 is read and the result is displayed in volts.

Condition	Displayed value
No UTH connected	0.0
TP9 connected to +5V	5.0

Tests 30 - 33: There are no test programs for service purposes under these numbers (reserved for production tests only).

Test 34: Oscillator test

The MF-output stage is driven with a 4kHz signal. To measure this frequency use a 400 - 500 Ohm resistor as a load for the output stage.

Test 35: Program for maximum output current adjustment

Connect a resistor of 400 - 500 Ohms to the electro-therapy output and connect in series a multimeter (range 0-100mA AC). Adjust with trimmer potentiometer P1005 the output current to 70.7 mA (equals 100mA top). See also chapter "Circuit adjustments".

Tests 36 - 37: There are no test programs for service purposes under these numbers (reserved for production tests only).

Test 38: Test for the MF-output stage

With the AMF sweep control, the frequency of the carrier wave can be controlled from approx. 4250 to 3000 Hz.

With the base AMF control, the modulation frequency can be controlled from 0 to 250 Hz.

With the current intensity control, the duty cycle of the Pulse Width Modulator (PWM) can be controlled from 0 to approx. 50%.

With the ultrasound mode selector, medium frequency direct current (position CW) or medium frequency alternating current (position PW) can be selected.

With the aid of this test, various control and feedback signals in the MF-output stage can be measured. For example, it is possible to check the functioning of the phase detector circuit. Output 0 (pin 5) of IC1015 should be '0' when the carrier wave frequency is too low, and '1' when it is too high.

Tests 39 - 46: There are no test programs for service purposes under these numbers (reserved for production tests only).

Test 47: Program for reading the efficiency of a UTH (C-value)

This test reads the setting of trimmer potentiometer Pcal in the treatment head. The setting of Pcal represents the efficiency factor of the crystal of the UTH. For the use of this test see chapter "Calibration of a repaired treatment head".

Connect a treatment head to the Sonopuls. The efficiency factor (C-value) of the treatment head is now read and the result, a value between 0 and 128, is displayed. If there is no treatment head connected to the Sonopuls the display shows 255.

Note: the most significant bit is in this test indicated by the display mode LEDs:

0 LEDs on: read 0 (- -)

1 LED on: read 1 (- -)

2 LEDs on: read 2 (- -)

The value between the brackets (- -) is the value shown on the display.

CHECKS AND CIRCUIT ADJUSTMENTS

1. GENERAL

- 1.1. After any repair and or maintenance, check:
 - a) that the original battery charger is used;
 - b) that the mains lead of the battery charger is in good condition;
 - c) the earth leakage current in the normal condition (N.C.) as well as in the single fault condition (S.F.C) according to the I.E.C. 601-1 regulations regarding class II, type BF equipment.
- 1.2. Check that the fuse (F1001) has the rating specified.
- 1.3. Check that all knobs, switches and the like are properly mounted. Check that the insulating bush (item 34) is mounted on the shafts of potentiometers P1007, P1008, P1009, P1010 and rotary switch S1001. Check that all connectors are properly fastened. Check that the test jumper (ST4) is in the home position.

2. SUPPLY VOLTAGES

- 2.1. Measure the following supply voltages with respect to ground (TP17):
 - +12 V +/- 2.0 V measured at CN4-10.
 - + 5 V +/- 0.25V measured at CN4-6.

3. CIRCUIT ADJUSTMENTS

General

For the circuit adjustments of the Sonopuls 464 a special dummy load is required (except adjustments 3.1 and 3.2).

By connecting the dummy load to the output socket of the Sonopuls, the equipment switches automatically to the 'ADJUSTMENT MODE'. Then the 'ADJUSTMENT ROUTINES', which are stored in the program memory of the Sonopuls, can be called by the service technician.

The first routine is always routine '66. The next routines ('77' and '88') can be called with the time setting switch:

- call for next routine: press to 'up';
- call for previous routine: press to 'down'.

Readjustment of the treatment head circuit is only necessary when:

- the front plate with crystal is exchanged;
- the p.c. board of the treatment head is exchanged.

DO NOT CHANGE THE SETTING OF THE POTENTIOMETERS OF THE TREATMENT HEAD FOR ANY OTHER REASON.

NOTES:

- The battery indicator ('batt') is off when the Sonopuls is in the adjustment mode.

- With some routines it is required to read a three-digit value. In that case, the most significant bit is indicated by the display mode LEDs:

●	●	●	0 LEDs 'on':	read 0 (- -)
min	W/cm2	W		
○	●	●	1 LED 'on':	read 1 (- -)
min	W/cm2	W		
○	○	●	2 LEDs 'on':	read 2 (- -)
min	W/cm2	W		

The value between the brackets (- -) is the value shown on the digital display.

For layout of controls and test points please fold-out page 55.

3.1 Adjustment of the battery charging current

- Switch off the Sonopuls 464 and disconnect the battery charger.
- CN8 Disconnect CN8 (battery connector) from the p.c.board. Connect an A-meter (e.g. 1A range) and 15 Ohm resistor (3W) in series and connect this circuit to the pins of CN8 on the p.c.board (CN8-2 is positive, CN8-1 is negative).
- P1006 Turn P1006 fully anti-clockwise. Connect the battery charger to the Sonopuls. Adjust with P1006 the current to approx. 350mA. Wait at least 3 minutes and allow the current drifting. Then adjust with P1006 the current to 400mA. Disconnect the battery charger and A-meter. Reconnect the battery.

3.2 Adjustment of the maximum MF output current

- Connect a resistor of 400 - 500 Ohms (3 Watts) to the electro-therapy output (Socket2) and connect in series an A-meter (range 0-100mA AC).
- ST4 Remove jumper ST4.
- Test 35 Switch on the Sonopuls 464 and select with the time setting switch test routine 35.
- P1005 Adjust with trimmer potentiometer P1005 the output current to 70.7 mA (equals 100mA peak value). Switch off the Sonopuls and disconnect the resistor and Ammeter. Put jumper ST4 back to the home position.

3.3

Check/adjustment of the ultrasound output stage and output power

CONNECT THE 'DUMMY LOAD' TO THE OUTPUT SOCKET AND SWITCH ON.
YOU HAVE NOW ENTERED THE ADJUSTMENT ROUTINES OF THE SONOPULS 464.

Test 66: Check/adjustment offset IC1004

WAIT Wait for the buzzer.
TP15 Connect a voltmeter (100mV range) to TP15 (+) and
TP17 TP17 (ground).
CHECK Check that the meter reading is between 15 and 25mV,
otherwise, readjust P1001 (see below).
P1001 Adjust with P1001 the voltage at TP15 to 20mV.
Disconnect voltmeter.

CALL THE NEXT ADJUSTMENT ROUTINE ('77') BY PRESSING THE TIME SETTING SWITCH TO 'UP'.

Test 77: Check/adjust the ultrasound output power and display (for UTH large)

WAIT Wait for the buzzer.
TP2 Connect a voltmeter (10V range) to TP2 (+) and
TP17 TP17 (ground)
CHECK Check that the meter reading is between 5.25V and 5.35V,
otherwise, readjust P1003 and P1004 (see below).
CHECK Check that the display indicates a reading between 1.97 and
2.03, otherwise, readjust P1003 and P1004 (see below).
P1003 Adjust with P1003 (Iinfo-large) the voltage at TP2 to 5.30V.
P1004 Adjust with P1004 (Uinfo) the value on the display to
'2.00' (see note below).

NOTE: the most significant bit is in this test indicated by the display mode LEDs:

0 LEDs 'on' : read 0.(- -)
1 LED 'on' : read 1.(- -)
2 LEDs 'on' : read 2.(- -)

The value between the brackets (- -) is the value shown on the display.

CALL THE NEXT ADJUSTMENT ROUTINE ('88') BY PRESSING THE TIME SETTING SWITCH TO 'UP'.

Test 88: Check/adjust the ultrasound output power (for UTH small)

WAIT Wait for the buzzer.
TP2 Connect a voltmeter (10V range) to TP2 (+) and
TP17 TP17 (ground).
CHECK Check that the meter reading is between 2.44V and 2.50V,
otherwise, readjust P1002 (see below)
P1002 Adjust with this control (Iinfo-small) the voltage at TP2
to 2.47V.

ADJUSTMENTS OF TREATMENT UNIT COMPLETED

3.4 Instructions to repair and calibrate a treatment head

Defective treatment heads can be repaired in the field.

In case the front plate of a treatment head is damaged, a new front plate, complete with crystal, can be ordered and fitted by the service technician. This spare part is delivered together with a test certificate indicating its efficiency (C-value).

To ensure the interchangeability of the treatment heads, the treatment head must be calibrated after exchanging the front plate.

In case the p.c. board of the treatment head is defective, a new board can be ordered and fitted by the service technician.

Important: before replacing the board, read the efficiency factor (C-value) of the crystal (i.e. the setting of trimmer potentiometer Pinfo) with the aid of test routine 47. Make a note of this value as it is a set value which is required later when calibrating the treatment head.

To ensure the interchangeability of the treatment heads, the treatment head must be calibrated after exchanging the p.c. board.

3.4.1. How to open the treatment head

Use the special key-wrench and unscrew the top cover from the head (see drawing below).

If further disassembly is required:

- Use the special key-wrench and unscrew the inner lock ring.
- Carefully unplug the three connectors.
- Take out the p.c. board.
- Remove the cable assy by unscrewing the coupling nut from the treatment head. Do this with care and guide the wires in the housing of the treatment head.
- Remove the inner (shielded) part of the housing, the contact-plate with spring contacts and the front plate to which the crystal is cemented. Take care not to lose or damage the seal of the crystal.

Reassembly is done in the reverse sequence.

Remark with respect to the large treatment head: take care that the contact pin (item 614) of the p.c. board is connected properly to the contact ring (item 611) between the p.c. board and the crystal.

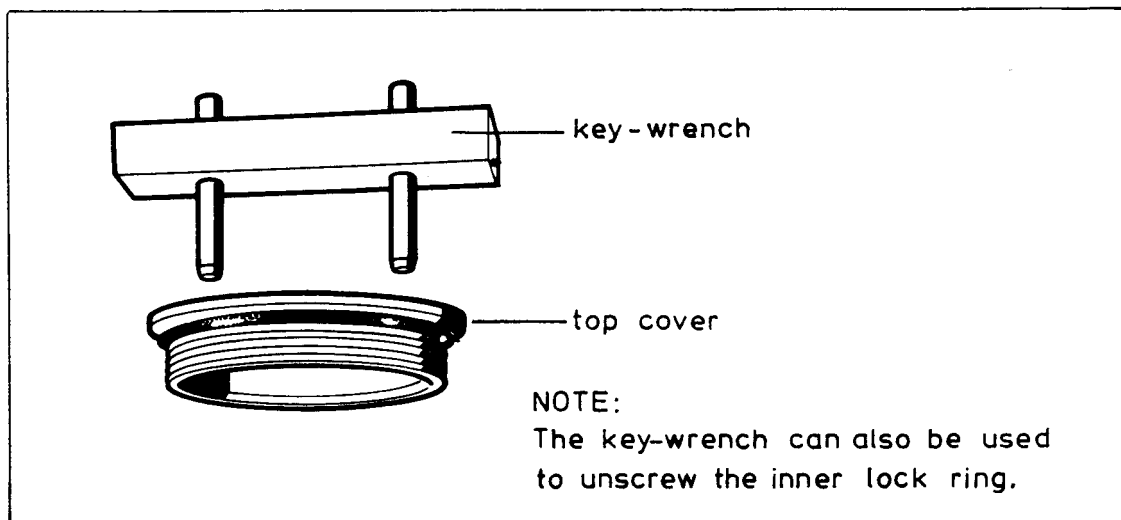

3.4.2. Calibration of a repaired treatment head.

IMPORTANT NOTES

- The adjustment of an ultrasound treatment head can only be done in combination with a calibrated (adjusted) SONOPULS 464.
- Calibration is only necessary in case the front plate with crystal is exchanged or when the p.c. board is exchanged.
- DO NOT CHANGE THE SETTING OF THE POTENTIOMETERS OF THE TREATMENT HEAD FOR ANY OTHER REASON.

To calibrate a repaired treatment head proceed as follows:

- Connect the treatment head to the output socket of the Sonopuls 464.
- Remove test jumper ST4.
- Switch on the Sonopuls 464 and select TEST ROUTINE 47 (push the time setting switch once to the left); the display indicates a value between 0 and 128 which shows the efficiency factor of the head. This value must correspond with the value on the test certificate (in case you have replaced the p.c. board this value must correspond with the value of which you have made a note).
- If this is not the case, the displayed value must be adjusted to that shown on the certificate by turning Pcal in the treatment head.
- Return the Sonopuls 464 to normal operating mode by putting the test jumper ST4 back to its home position and by switching the unit off and on again.
- Select the continuous ultrasound mode, set the timer, set the display mode selector to position " W/cm^2 " and turn the intensity control to maximum ($1W/cm^2$). Apply the treatment head to an ultrasonic test bath; the display should indicate 1.0 (W/cm^2). Important: to prevent reflections of the ultrasound beam and hence an incorrect display value, the bath must be filled with degassed water.
- If this is not the case, the displayed value must be adjusted to 1.0 by turning trimmer potentiometer Pinfo in the treatment head.
- Put the treatment head in an ultrasonic phantom and check that there is ultrasonic output power.

CALIBRATION OF TREATMENT HEAD COMPLETED

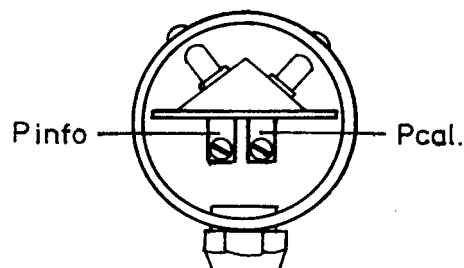

Top view of treatment head
with top cover removed.

4. FUNCTION TEST

4.1 Self-test

Disconnect all accessories. Switch on the Sonopuls and check that all LEDs and display segments light. If the buzzer sounds then the Sonopuls has passed the self-test, otherwise see chapter "Fault conditions".

4.2 Controls and indicators

Check the functioning of all controls, indicators and switches. This can be done with the aid of test routines 9...18 (except test 15).

Connect the battery charger to the Sonopuls 464. Check that the charger indicator lights.

Switch off the Sonopuls and put the jumper ST4 back to the home position.

4.3 US-output

Connect a large UTH to the Sonopuls 464.

Switch on.

Set mode switch in position ultrasound therapy.

Select continuous ultrasound mode.

Set treatment time.

Turn intensity control fully anti-clockwise.

Select display mode W/cm².

Check that the display shows ".05" (flashing).

Turn the intensity control fully clockwise.

Check that the display shows "1.0" (flashing).

Use the ultrasound test bath and check that there is acoustical power.

4.4 MF-output

Check the output current in both the alternating- and direct current mode with the aid of an oscilloscope and a 400 - 500 Ohm load resistor (3W).

Check that the max. current lies between 95 and 105mA.

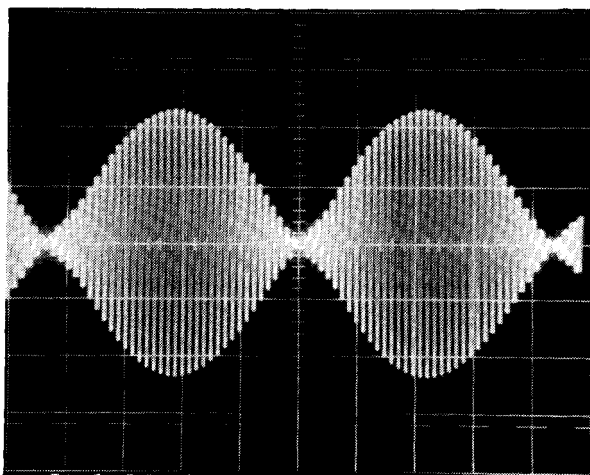

Alternating current mode

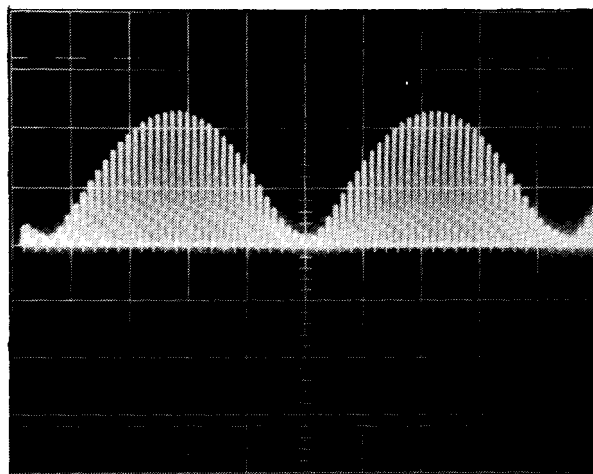

Direct current mode

Sonopuls 464:

AMF: 120 Hz

I : 100 mA

load resistor : 470 ohm

scope:

ampl: 20V/div

time: 2ms/div

4.5 Accessories

To test the treatment heads, connect the head to the Sonopuls 464 and switch on. If the Sonopuls passes the self-test then the head is o.k. To complete the test, check with the test bath if the head transfers acoustical output power. Also check the functioning of the UTH as electrode in combined therapy mode.

Check the patient cable and (rubber) electrodes for intermittent contacts. Measure with an Ohm-meter the resistance of the flexible rubber electrodes; connect the electrode lead to the meter and use a test lead with bananaplug as test probe. Measure the resistance at several points of the electrode surface (test both sides of the electrode). The measured resistance should not exceed 2000 Ohms.

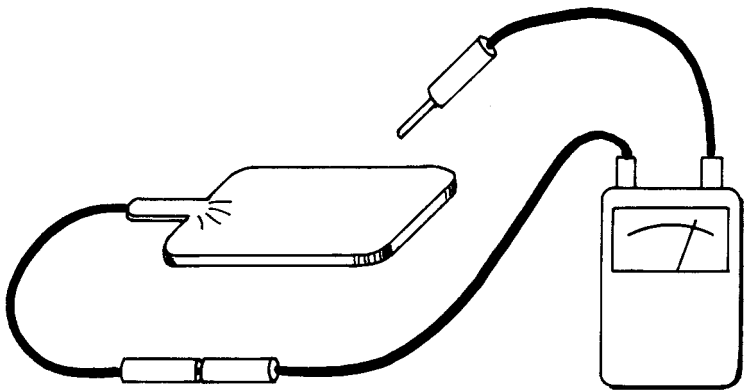

≤ 2000 Ohm

MAINTENANCE

We advise to subject the Sonopuls 464 to regular inspections (e.g. once a year) to guarantee the safety and functioning of the apparatus as specified. During inspection carry out the following items:

1. Modifications (if any). The information in this manual is effective as from date of publication. Modifications are published by means of Technical Info sheets (T.I.'s). For up to date modifications please contact your authorized service dealer.
 2. Carry out the function test on pages 52, 53.
 3. Carry out the safety tests on page 46 (item 1).
 - 4.* In accordance with the FDA regulations, verify the ultrasound output of the Sonopuls 464 with each treatment head using an Ohmic UPM-30 ultrasound output meter.
 5. Fill out the "File of maintenance and repairs" enclosed in this manual. Keep a copy of this file with the equipment.
- *) Applies to the U.S.A only.

R.G. BOARD 1

105-109

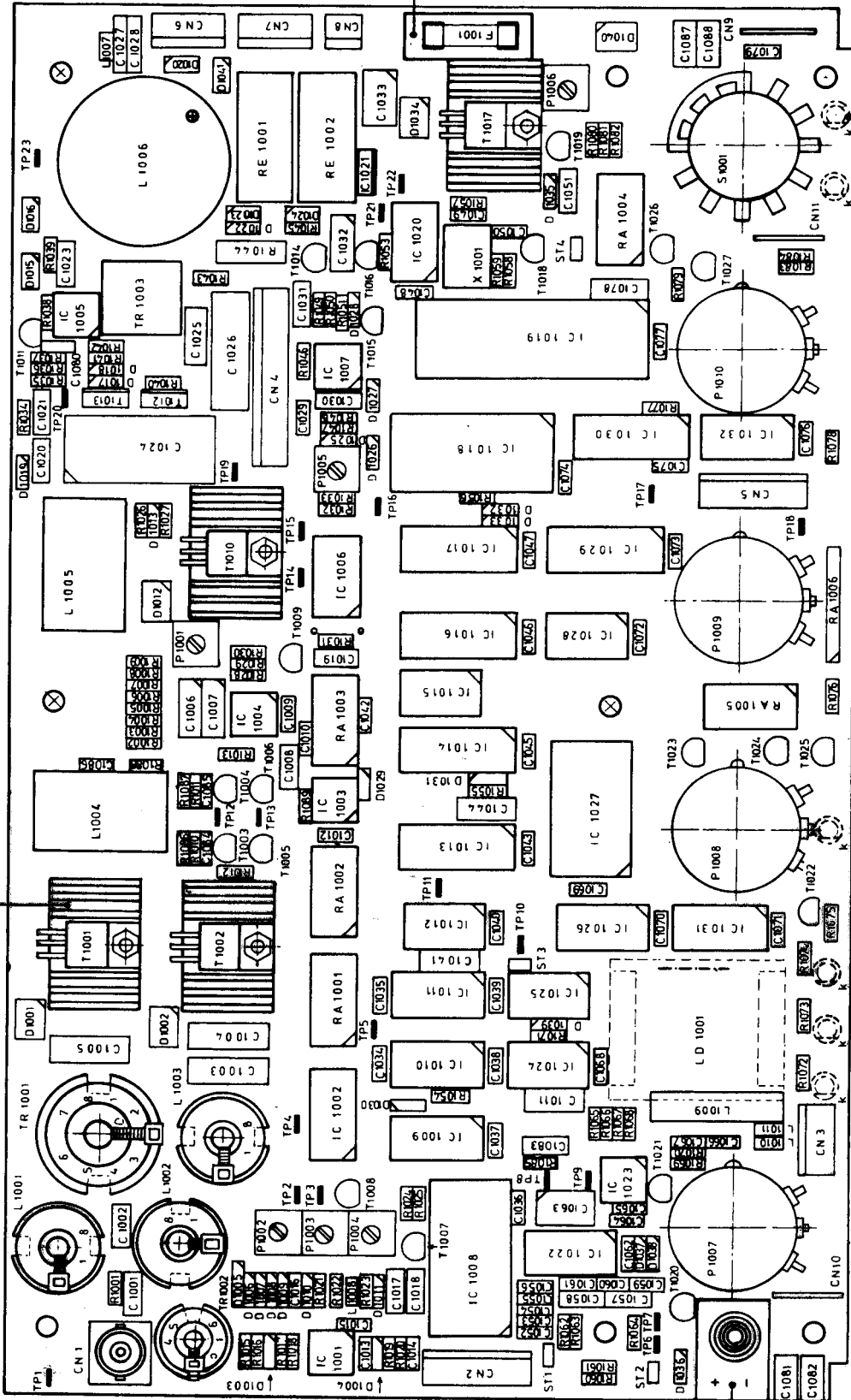

IT1001

91

90

HOUSING, sectional drawing

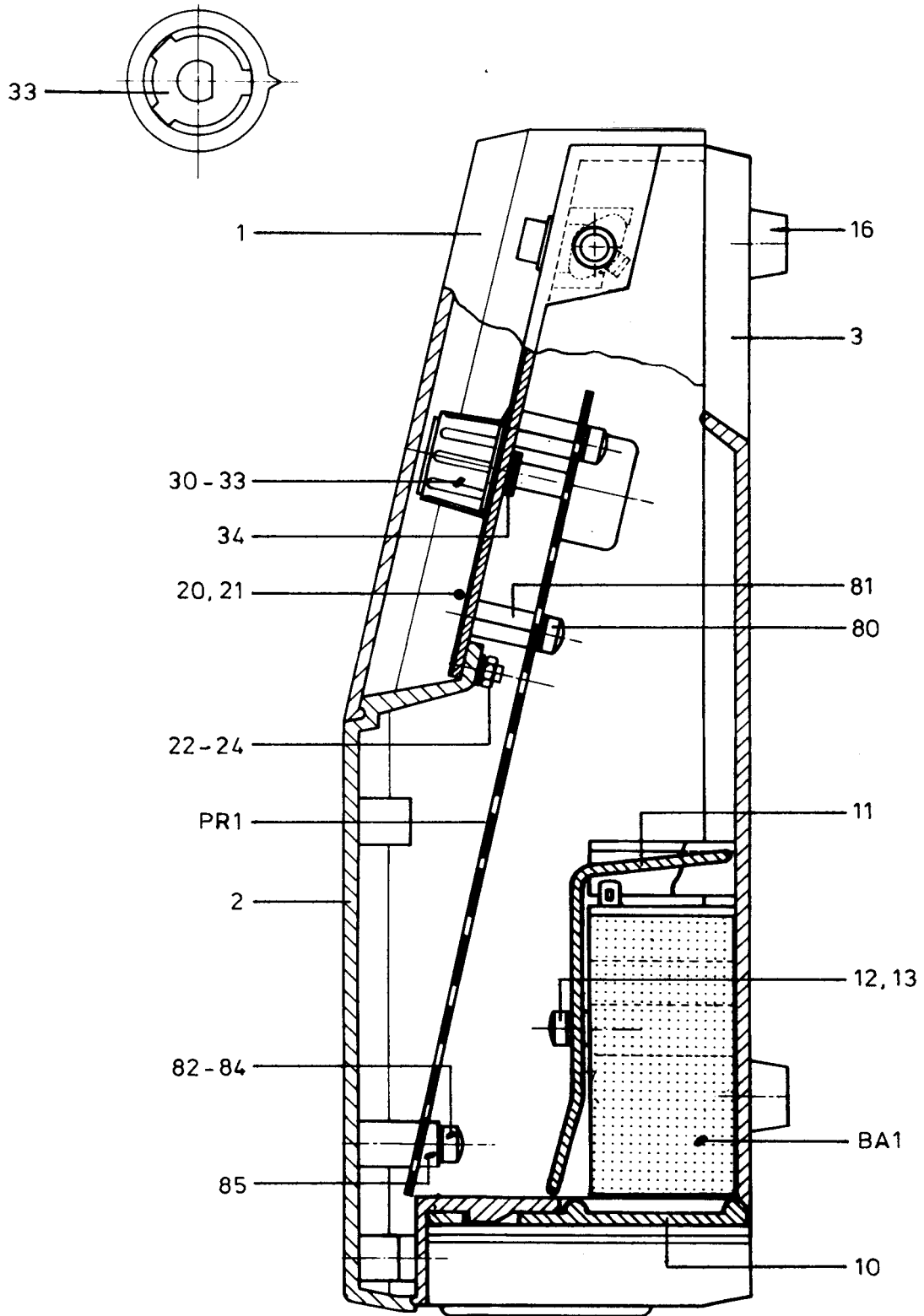

FRONT PANEL

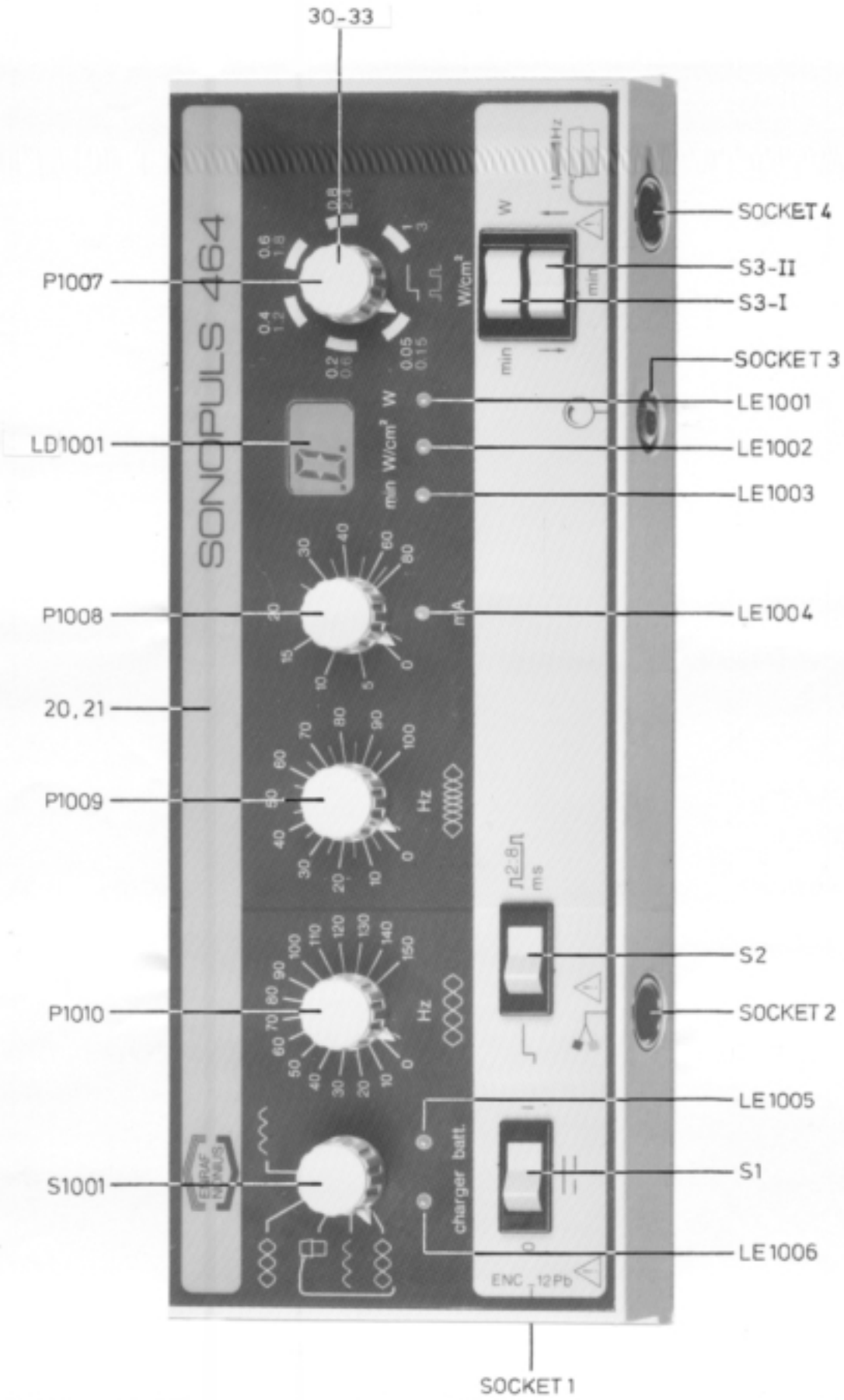

INTERIOR

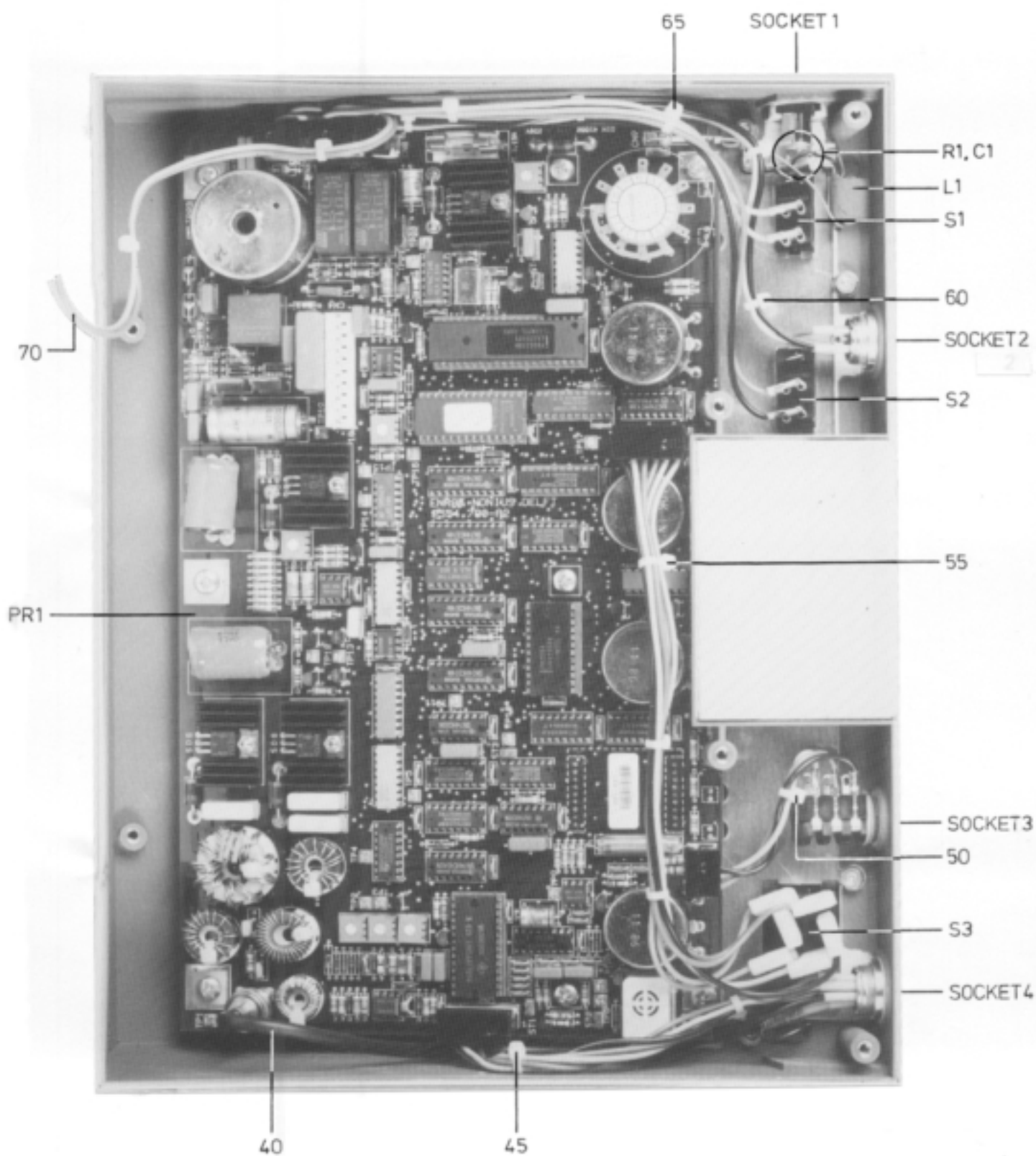

BATTERY CHARGER

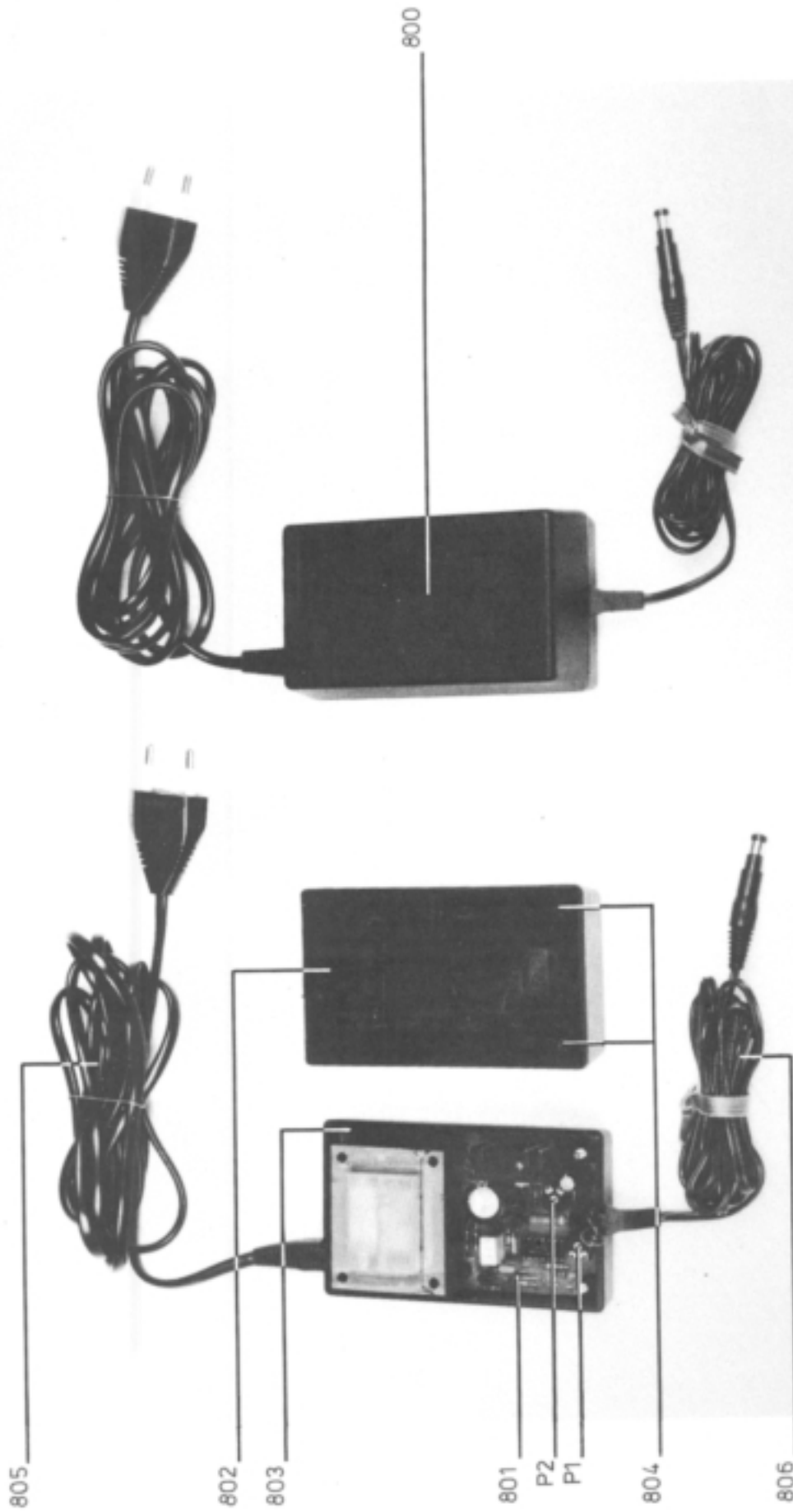

ENC 3444.294-6 12V Pb

ENC

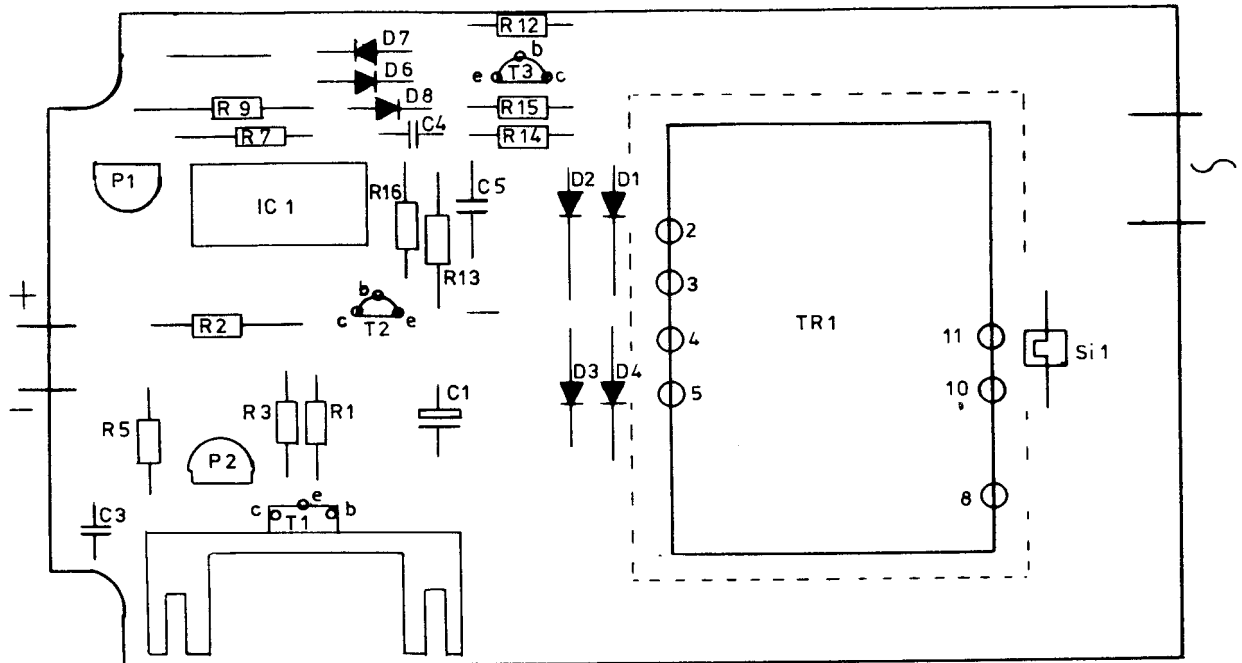

ENC

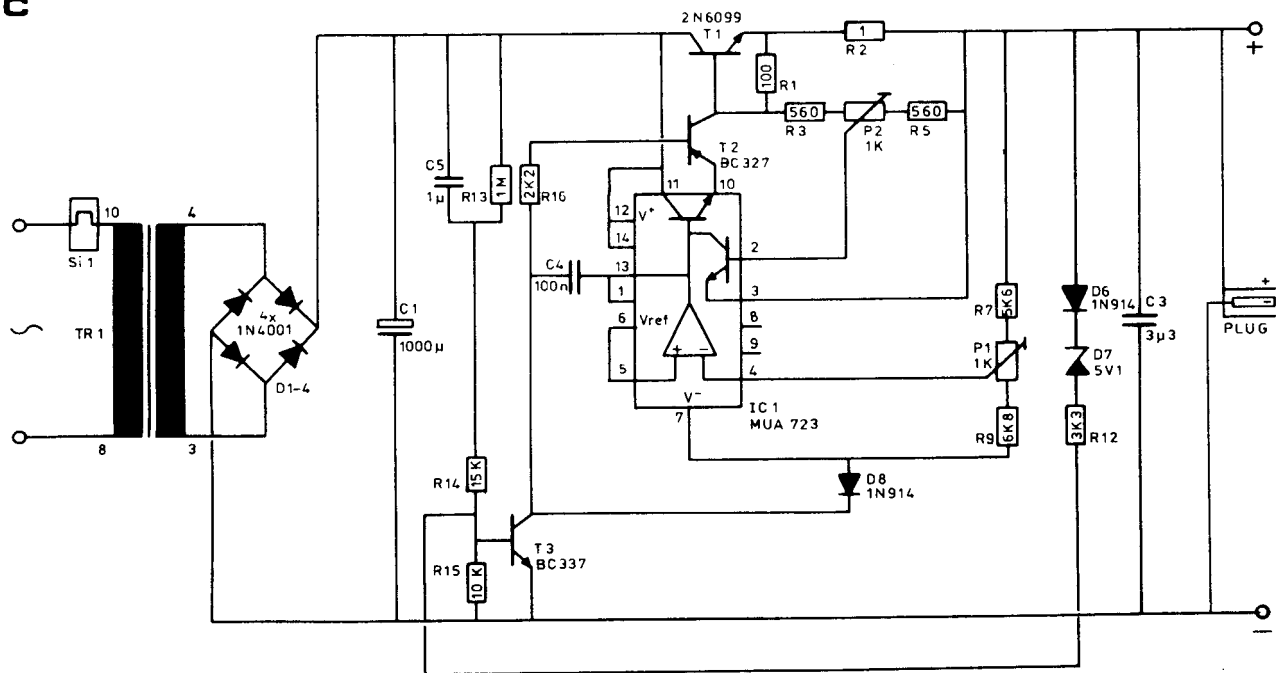

CIRCUIT DIAGRAM CHARGER ENC 3444 294/295/296
(110/220/240 V)

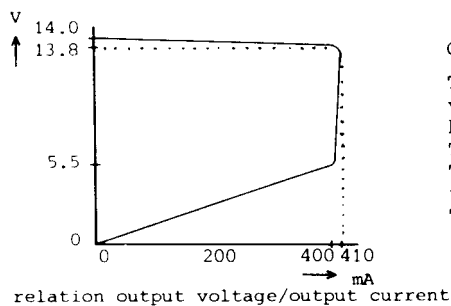

Charger ENC 3444 294/295/296 (110V/220V/240V)

This charger adjusts its output current, depending on the battery voltage so that a minimum charge time is obtained and so that the battery is protected against overcharge. The charge current is limited with P2 to 400 mA. This can be measured with a resistor (15 - 25 Ohm) in series with the mA-meter. The maximum output voltage is adjusted with P1 to 14.0 Volt.

UTH SMALL 1MHZ

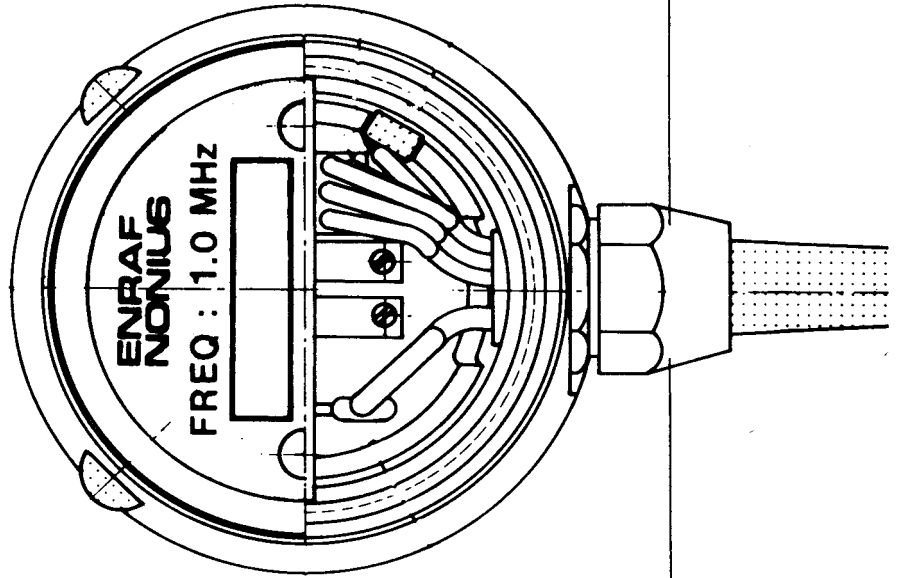
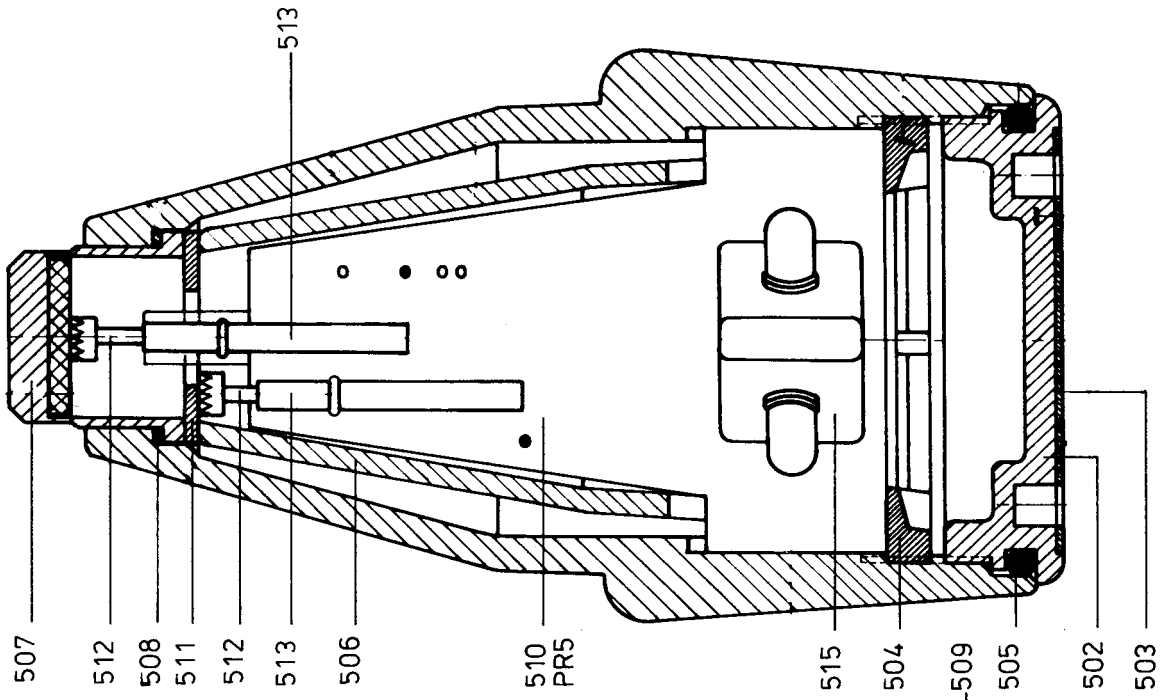

UTH LARGE 1MHZ

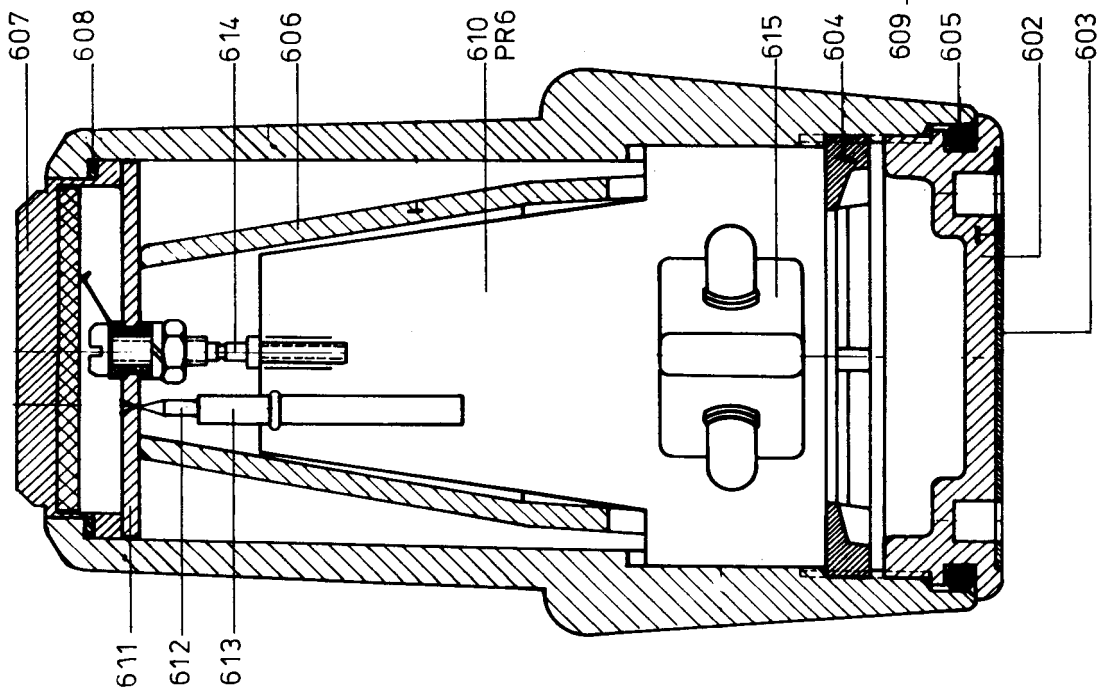

INSIDE VIEW, DISASSEMBLED

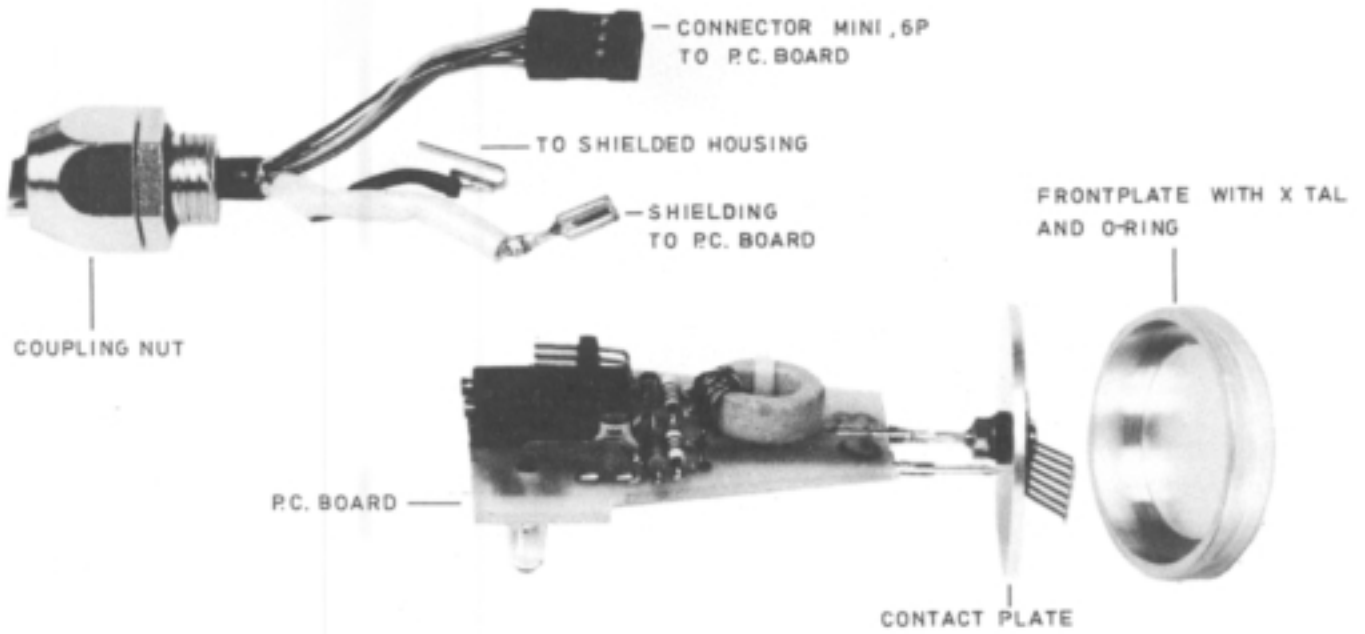

P.C. BOARD 5, 6

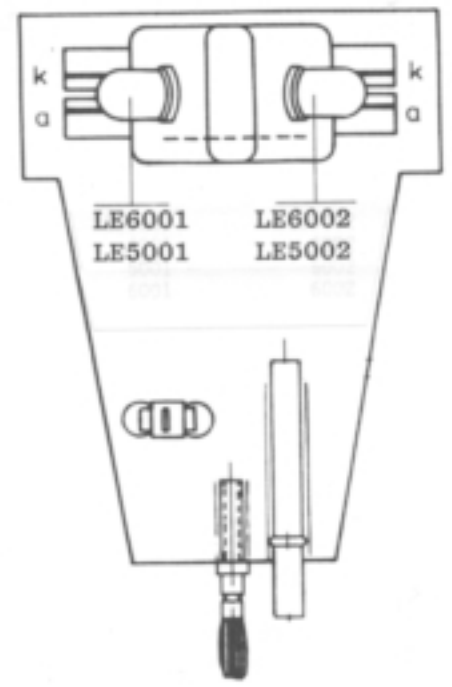
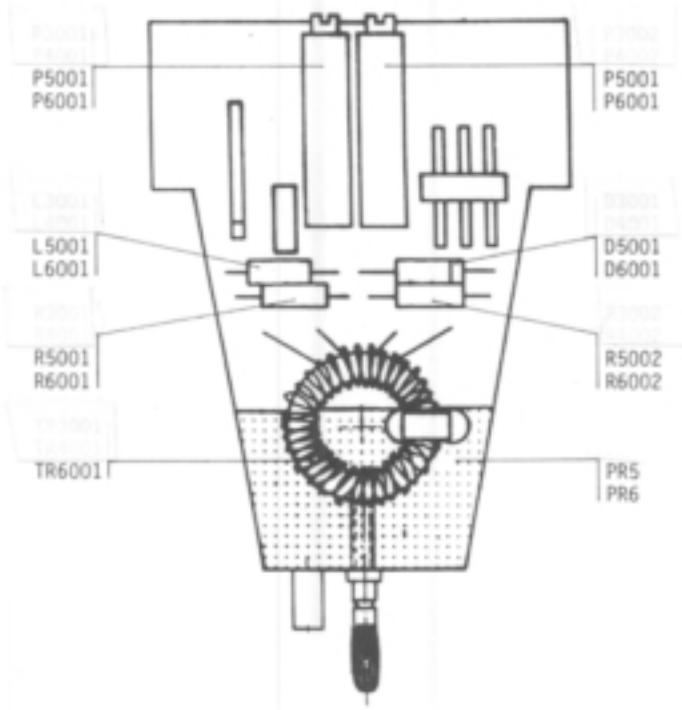

609, cable complete, 1MHz-large
 509, cable complete, 1MHz-small

620, red
 520, green

PL1

621

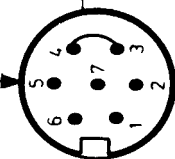
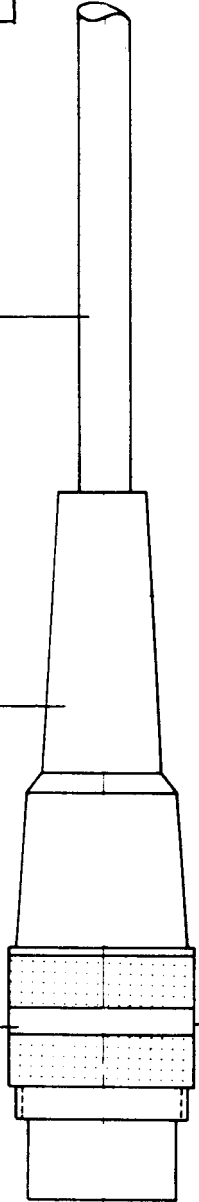

- 1 shielding
- 2 black and green
- 3 brown
- 4 yellow
- 5 red
- 6 red
- 7 amber



1MHz, large

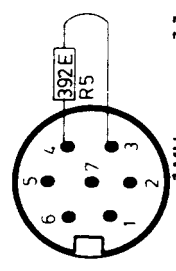

1MHz, small

connect to p.c board
 in this position

amber

623

622

624, 625

to shielded
 housing

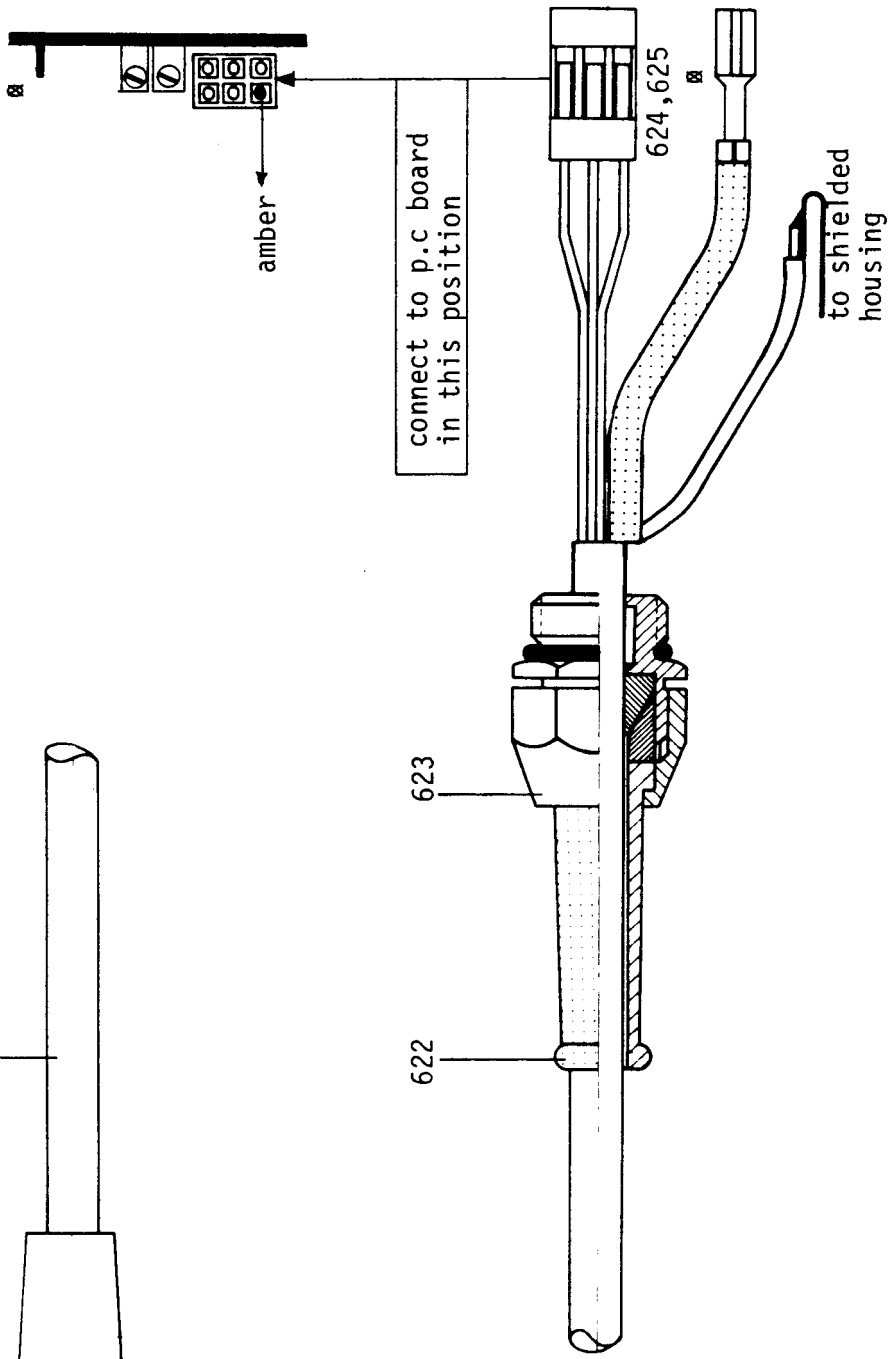

ACCESSORIES

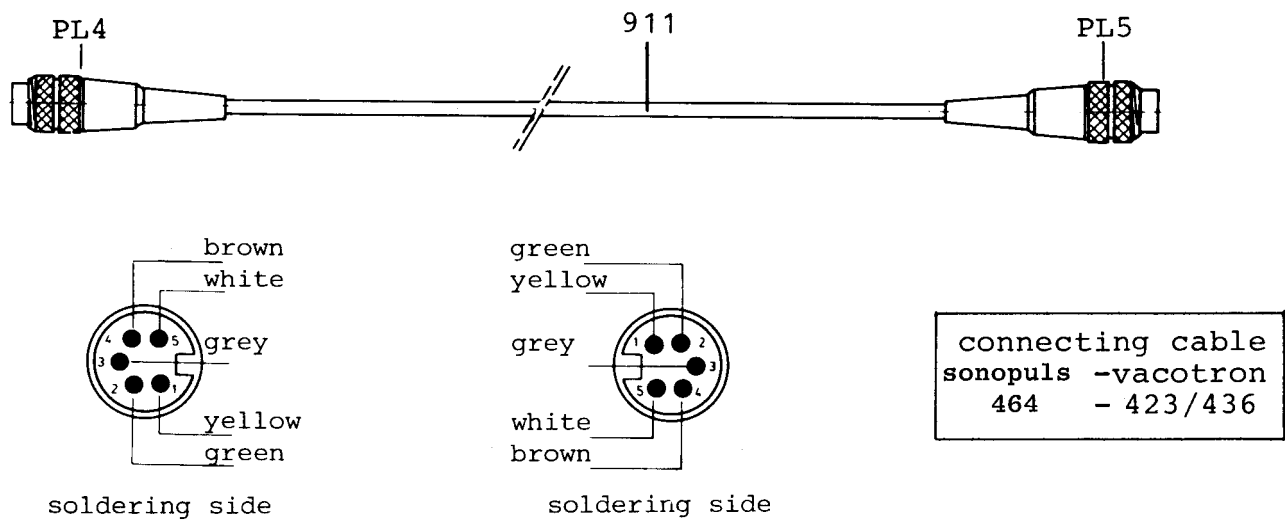
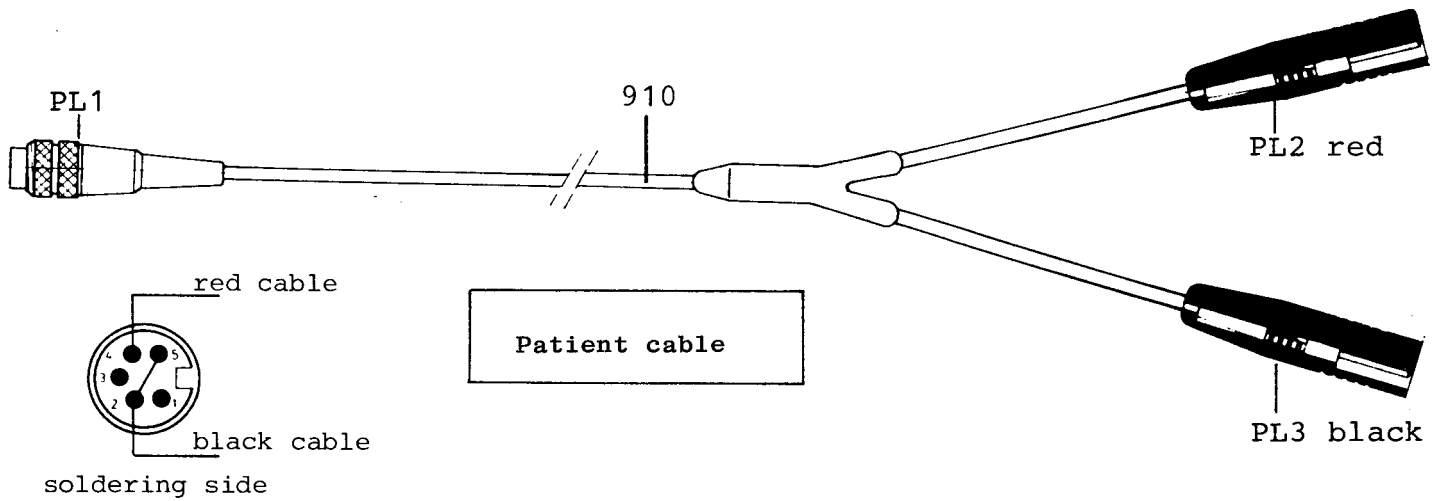

RECOMMENDED TOOLS

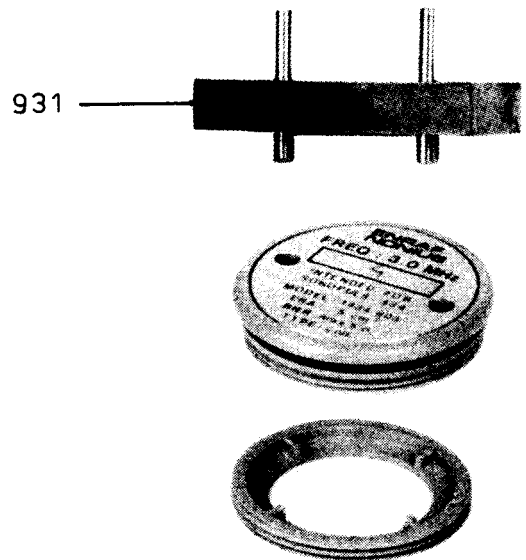
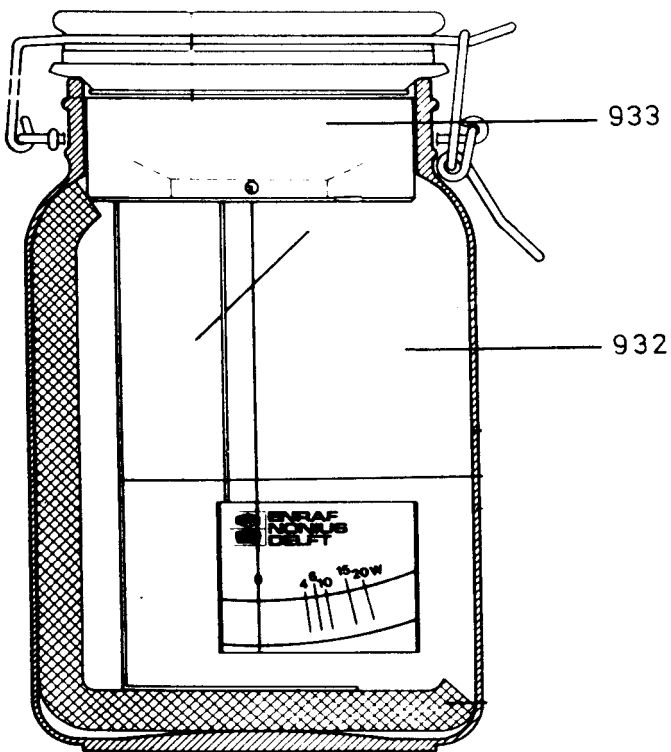
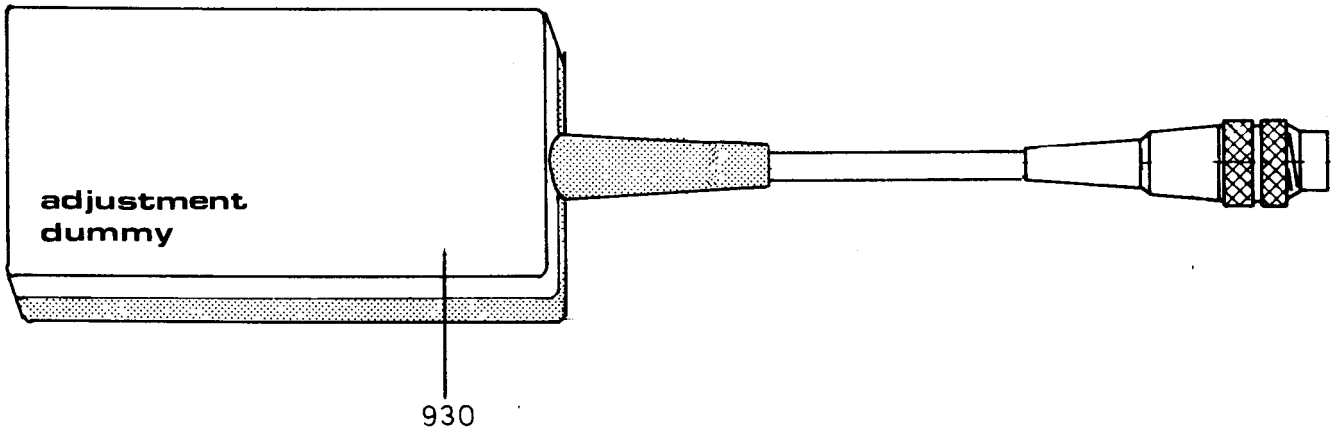

IMPORTANT:

This instrument is recommended as a test bath only. It can be used as an acoustical load for the treatment heads. Note that the meter is calibrated for 15W and that it cannot be used to measure the output power of the SONOPULS 464 (max. power 5W CW).

item	description	ref. no.	electrical data remarks
	SONOPULS 464, complete with standard accessories	1464.901	220V, 50 - 60Hz (battery charger with IEC mains cable)
	SONOPULS 464, complete with standard accessories	1464.902	110V, 50 - 60Hz (battery charger with UL-CSA mains cable)
	SONOPULS 464, complete with standard accessories	1464.906	240V, 50 - 60Hz (battery charger with UK mains cable)
	Battery charger ENC 12 Pb	3444.295	220V, 50 - 60Hz, IEC
	Battery charger ENC 12 Pb	3444.294	110V, 50 - 60Hz, UL-CSA
	Battery charger ENC 12 Pb	3444.296	240V, 50 - 60Hz, UK

HOUSING

1	Lid	2994.139	
2	Housing, upper part	2994.137	
3	Housing, base	2994.144	
4	Screw, cross-slotted (4x)	6006.027	M4x16
5	Screw, cross-slotted (2x)	6006.025	M4x10
6	Washer, spring (6x)	6083.104	M4
10	Battery compartment lid	2994.076	
11	Battery cover	2994.075	
12	Screw, cross-slotted (2x)	6006.027	M4x16
13	Washer, spring (2x)	6083.104	M4
15	Type plate	on demand	
16	Support (4x)	2032.053	
	-Front panel-		
20	Indication plate	2077.180	polycarbonate
21	Supporting plate	0166.094	aluminium
22	Nut (6x)	6064.004	M4
23	Washer, spring (6x)	6083.104	M4
24	Washer, flat (6x)	6076.504	M4
25	Solder tag, for ground to shield connection	6958.015	only series 1-3
30	* Control knob (5x), complete with pointer and locking key	0404.300	
31	* Knob cap (5x)	2071.553	
34	* Insulation bush (5x), for potentiometer shafts and shaft of rotary switch	2994.309	

ELECTRICAL PARTS

40	Coaxial cable, CN1 to Socket4, including: CN1 (female part), CN10 (female part), item 41.	0463.600 2270.079 2590.298	complete assy (from series 4)
41	Crimp sleeve, for shielding of coaxial cable	2590.044	

* We advise to keep marked items in stock

item	description	ref. no.	electrical data remarks
45	Cable, CN2 to Socket4, including: CN2 (female part), cap for connector housing CN2.	on demand 2524.641 2524.643	complete assy 6p
50	Cable, CN3 to Socket3, including: CN3 (female part), cap for connector housing CN3.	on demand 2524.640 2524.605	complete assy 4p
55	Cable, CN5 to S3, including: CN5 (female part), cap for connector housing CN5, items 56 and 57.	on demand 2524.641 2524.643	complete assy 6p
56	Crimp connector (6x), receptacle	2590.275	for S3, 6.3x0.8mm
57	Cover (6x), for crimp connector	2590.269	
60	Cable, CN6 to Socket2, including: CN6 (female connector), cap for connector housing CN6.	on demand 2524.640 2524.605	complete assy 4p
65	Cable, CN7 to S1/S2, including: CN7 (female part), cap for connector housing CN7, item 66.	on demand 2524.640 2524.605	complete assy 4p
66	Crimp connector, receptacle (4x)	2590.275	for S1/S2, 6.3x0.8mm
70	Cable, CN8 to battery, including: CN8 (female part), cap for connector housing CN8, item 71.	on demand 2524.677 2524.676	complete assy 2p
71	Crimp connector, receptacle (2x)	2590.249	4.8x0.8mm
BA1	* Battery	2501.016	Pb, 12V, 1.8Ah
C1	Capacitor	2581.410	10n 63V
L1	Coil	0463.500	
L2	Coil	0464.502	
L3	Coil	0464.502	
R1	Resistor (only series 1-3)	2713.241	330E 0.4W 5%
S1	* On/off switch	2601.263	single pole, two-way
S2	Selector ultrasound mode	2601.263	single pole, two-way
S3	* Display mode selector switch/ treatment time selector switch	2601.379	
Socket1*	Input for battery charger	2524.740	
Socket2*	Output for patient cable	2523.266	5-pole female
Socket3*	Input for intensity remote control	2524.704	3-pole, 6.4 mm
Socket4*	Ouput for treatment head	2523.277	7-pole female

* We advise to keep marked items in stock

item	description	ref. no.	electrical data remarks
<u>P.C.BOARD 1</u>			
PR1	* P.C. Board 1, complete assy	0464.690	
80	Screw, combi, cross-slotted (5x)	2146.603	M4x8mm
81	Spacer, hex. (5x)	2291.639	M4, length = 13mm
82	Screw, cross-slotted (3x)	6006.027	M4x16mm
83	Washer, spring (3x)	6083.104	M4
84	Washer, flat (3x)	6076.504	M4
85	Matching piece (3x)	2994.141	plastic
90	Spacer, for LE1001 - LE1006 (6x)	2994.072	
91	Fuse holder	2656.053	
100	IC socket, 20p SIL, (pin strip)	2641.537	for LD1001
101	IC socket, 20p DIL (2x)	2641.555	for IC1029 and IC1030
102	IC socket, 28p DIL (2x)	2641.559	for IC1008 and IC1018
103	IC socket, 40p DIL	2641.561	for IC1019
104	IC socket, 24p DIL	2641.558	for IC1027
105	Heat sink (4x), for T1001, T1002, T1010, T1017	2564.040	
106	Screw (4x)	6215.036	M3x16mm
107	Spacer (4x)	0165.721	
108	Washer, spring (4x)	6083.103	M3
109	Nut (4x)	6064.003	M3
C1001	Capacitor	2581.227	270pF
C1002	Capacitor	2581.256	560pF
C1003	Capacitor	2534.689	6n8
C1004	Capacitor	2534.689	6n8
C1005	Capacitor	2534.689	6n8
C1006	Capacitor	2580.661	6u8
C1007	Capacitor	2580.661	6u8
C1008	Capacitor	2583.361	6n8
C1009	Capacitor	2581.410	10n
C1010	Capacitor	2581.339	3n9
C1011	Capacitor	2583.601	1uF
C1012	Capacitor	2581.410	10nF
C1013	Capacitor	2581.410	10nF
C1014	Capacitor	2581.410	10nF
C1015	Capacitor	2581.210	100pF
C1016	Capacitor	2581.210	100pF
C1017	Capacitor	2583.501	100nF
C1018	Capacitor	2583.501	100nF
C1019	Capacitor	2583.411	15nF
C1020	Capacitor	2583.501	100nF

* We advise to keep marked items in stock

item	description	ref. no.	electrical data remarks
C1021	Capacitor	2583.501	100nF
C1022	(Deleted)		
C1023	Capacitor	2583.501	100nF
C1024	Capacitor	2580.905	1000u
C1025	Capacitor	2583.601	1uF
C1026	Capacitor	2537.081	1uF
C1027	Capacitor	2533.118	100pF
C1028	Capacitor	2533.118	100pF
C1029	Capacitor	2581.222	220pF
C1030	Capacitor	2583.501	100nF
C1031	Capacitor	2583.501	100nF
C1032	Capacitor	2580.661	6u8
C1033	Capacitor	2580.802	100uF
C1034	Capacitor	2581.410	10nF
C1035	Capacitor	2581.410	10nF
C1036	Capacitor	2581.410	10nF
C1037	Capacitor	2581.410	10nF
C1038	Capacitor	2581.410	10nF
C1039	Capacitor	2581.410	10nF
C1040	Capacitor	2581.410	10nF
C1041	Capacitor	2583.601	1uF
C1042	Capacitor	2581.312	1n2
C1043	Capacitor	2581.410	10n
C1044	Capacitor	2583.601	1uF
C1045	Capacitor	2581.410	10nF
C1046	Capacitor	2581.410	10nF
C1047	Capacitor	2581.410	10nF
C1048	Capacitor	2581.410	10nF
C1049	Capacitor	2581.122	22pF
C1050	Capacitor	2581.122	22pF
C1051	Capacitor	2583.501	100nF
C1052	Capacitor	2581.410	10nF
C1053	Capacitor	2581.410	10nF
C1054	Capacitor	2581.410	10nF
C1055	Capacitor	2581.410	10nF
C1056	Capacitor	2581.410	10nF
C1057	Capacitor	2583.501	100nF
C1058	Capacitor	2583.501	100nF
C1059	Capacitor	2581.410	10nF
C1060	Capacitor	2581.410	10nF
C1061	Capacitor	2581.410	10nF
C1062	Capacitor	2581.410	10nF
C1063	Capacitor	2580.802	100uF
C1064	Capacitor	2581.410	10nF
C1065	Capacitor	2581.410	10nF
C1066	Capacitor	2581.410	10nF
C1067	Capacitor	2581.410	10nF
C1068	Capacitor	2581.410	10nF
C1069	Capacitor	2581.410	10nF
C1070	Capacitor	2581.410	10nF

* We advise to keep marked items in stock

item	description	ref. no.	electrical data	remarks
C1071	Capacitor	2581.410	10nF	
C1072	Capacitor	2581.410	10nF	
C1073	Capacitor	2581.410	10nF	
C1074	Capacitor	2581.410	10nF	
C1075	Capacitor	2581.410	10nF	
C1076	Capacitor	2581.410	10nF	
C1077	Capacitor	2581.410	10nF	
C1078	Capacitor	2583.601	1uF	
C1079	Capacitor	2581.410	10nF	
C1080	Capacitor	2581.227	270pF	
C1081	Capacitor, from series 4	2534.119	1nF	3kV
C1082	Capacitor, from series 4	2534.119	1nF	3kV
C1083	Capacitor, from series 3	2583.431	33nF	
C1084	Capacitor, from series 4	2581.222	220pF	
C1085	Capacitor, from series 4	2581.222	220pF	
C1086	Capacitor, from series 4	2581.322	2n2	
C1087	Capacitor, from series 4	2534.119	1nF	3kV
C1088	Capacitor, from series 4	2534.119	1nF	3kV
CN1	Connector, BNC, female part	2524.809		
	Connector, BNC, male part	2270.079		
CN2	Connector, male part	2524.638	6p	
	Connector, female part, excluding cap for connector housing	2524.641	6p	
		2524.643		
CN3	Connector, male part	2524.607	4p	
	Connector, female part, excluding cap for connector housing	2524.640	4p	
		2524.605		
CN4	Connector, male part	2524.639	10p	
CN5	Connector, male part	2524.638	6p	
	Connector, female part, excluding cap for connector housing	2524.641	6p	
		2524.643		
CN6	Connector, male part	2524.607	4p	
	Connector, female part, excluding cap for connector housing	2524.640	4p	
		2524.605		
CN7	Connector, male part	2524.607	4p	
	Connector, female part, excluding cap for connector housing	2524.640	4p	
		2524.605		
CN8	Connector, male part	2524.675	2p	
	Connector, female part, excluding cap for connector housing	2524.677	2p	
		2524.676		
CN9	Connector, p.c.b. mounting blade	2590.039	male part	
	Crimp connector, receptacle	2590.298	2.8x0.8mm	
CN10	Connector, p.c.b. mounting blade	2590.039	from series 4	
	Crimp connector, receptacle	2590.298	2.8x0.8mm	
CN11	Connector, p.c.b. mounting blade	2590.039	from series 4	
	Crimp connector, receptacle	2590.298	2.8x0.8mm	

* We advise to keep marked items in stock

item	description	ref. no.	electrical data remarks
D1001	* Diode	2562.131	SB540
D1002	Diode	2562.131	SB540
D1003	* Diode	2563.095	1N914
D1004	Diode	2563.095	1N914
D1005	* Diode	2563.312	AA144
D1006	Diode	2563.095	1N914
D1007	Diode	2563.095	1N914
D1008	Diode	2563.095	1N914
D1009	Diode	2563.095	1N914
D1010	Diode	2563.095	1N914
D1011	Diode	2563.095	1N914
D1012	Diode	2562.131	SB540
D1013	Diode	2563.095	1N914
D1014	(Deleted)		
D1015	* Diode	2563.366	BZT03C75
D1016	Diode	2563.366	BZT03C75
D1017	Diode	2563.095	1N914
D1018	Diode	2563.095	1N914
D1019	Diode	2563.095	1N914
D1020	* Diode	2563.370	BYV95C
D1021	Diode (only series 1)	2563.370	BYV95C
D1022	* Diode, zener	2563.203	ZPD33
D1023	* Diode	2563.129	1N4006
D1024	Diode	2563.129	1N4006
D1025	Diode	2563.095	1N914
D1026	Diode	2563.095	1N914
D1027	Diode	2563.095	1N914
D1028	Diode	2563.095	1N914
D1029	Diode	2563.095	1N914
D1030	Diode	2563.095	1N914
D1031	Diode	2563.095	1N914
D1032	Diode	2563.095	1N914
D1033	Diode	2563.095	1N914
D1034	Diode	2562.131	SB540
D1035	Diode	2563.095	1N914
D1036	Diode	2563.095	1N914
D1037	Diode	2563.095	1N914
D1038	Diode	2563.095	1N914
D1039	Diode	2563.095	1N914
D1040	Diode	2562.131	SB540
D1041	Diode	2563.370	BYV95C
F1001	* Fuse	2655.180	3.15 AT, 250V

* We advise to keep marked items in stock

item	description	ref. no.	electrical data remarks
IC1001	* Integrated Circuit	2519.343	CA3240E
IC1002	* Integrated Circuit	2514.520	HEF4520
IC1003	Integrated Circuit	2519.343	CA3240
IC1004	* Integrated Circuit	2519.332	CA3140
IC1005	* Integrated Circuit	2519.031	TL331
IC1006	* Integrated Circuit	2519.022	LM339
IC1007	Integrated Circuit	2519.343	CA3240
IC1008	* Integrated Circuit	2518.572	ADC0809
IC1009	* Integrated Circuit	2518.086	74HC4040
IC1010	* Integrated Circuit	2514.104	HEF4104
IC1011	* Integrated Circuit	2514.518	HEF4518
IC1012	* Integrated Circuit	2521.000	74HC00
IC1013	* Integrated Circuit	2521.374	74HC374
IC1014	Integrated Circuit	2521.374	74HC374
IC1015	* Integrated Circuit	2517.074	74HCT74
IC1016	Integrated Circuit	2521.374	74HC374
IC1017	Integrated Circuit	2521.374	74HC374
IC1018	* Integrated Circuit	0464.703	27C256
IC1019	* Integrated Circuit	2518.848	80C31
IC1020	* Integrated Circuit	2517.014	74HCT14
IC1021	* Integrated Circuit	2519.218	7805
IC1022	* Integrated Circuit	2514.051	HEF4051
IC1023	Integrated Circuit	2519.332	CA3140
IC1024	* Integrated Circuit	2521.002	74HC02
IC1025	* Integrated Circuit	2514.070	HEF4070
IC1026	* Integrated Circuit	2518.088	74HC4543
IC1027	* Integrated Circuit	2519.074	82C54
IC1028	* Integrated Circuit	2514.081	HEF4081
IC1029	* Integrated Circuit	2517.245	74HCT245
IC1030	* Integrated Circuit	2517.373	74HCT373
IC1031	Integrated Circuit	2518.088	74HC4543
IC1032	* Integrated Circuit	2521.138	74HC138
IT1001	* Buzzer	2675.015	8-16V DC
IT1002	* Jumper for ST4	2524.387	
L1001	Coil	2670.124	1u6
L1002	* Coil	2670.125	4u9
L1003	* Coil	2670.124	1u6
L1004	* Coil	2670.126	100uH
L1005	Coil	2670.126	100uH
L1006	* Coil	0464.501	1.58mH
L1007	Coil	2670.059	18uH
L1008	* Coil	2670.118	1000uH
L1009	Coil	2670.111	13uH
L1010	Coil	2670.059	18uH
L1011	Coil	2670.059	18uH
LD1001	* Liquid Crystal Display	2562.705	LSS-5020-FP

* We advise to keep marked items in stock

item	description	ref. no.	electrical data		
			remarks		
LE1001	* Light Emitting Diode, green	2562.387	MV5453		
LE1002	Light Emitting Diode, green	2562.387	MV5453		
LE1003	Light Emitting Diode, green	2562.387	MV5453		
LE1004	* Light Emitting Diode, red	2562.318	MV5753		
LE1005	* Light Emitting Diode, green/red	2562.384	GLNP5		
LE1006	Light Emitting Diode, green	2562.387	MV5453		
P1001	Potentiometer, trimmer	2639.492	10k	0.5W	10%
P1002	Potentiometer, trimmer	2639.128	200E	0.5W	10%
P1003	Potentiometer, trimmer	2639.054	50E	0.5W	10%
P1004	Potentiometer, trimmer	2639.269	2k	0.5W	10%
P1005	Potentiometer, trimmer	2639.492	10k	0.5W	10%
P1006	Potentiometer, trimmer	2639.010	10E	0.5W	10%
P1007	* Potentiometer	2639.497	10k	2W	10%
P1008	Potentiometer	2639.497	10k	2W	10%
P1009	Potentiometer	2639.497	10k	2W	10%
P1010	Potentiometer	2639.497	10k	2W	10%
R1001	Resistor	2713.161	47E	0.25W	5%
R1002	Resistor	2685.999	0.22E	0.4W	1%
R1003	Resistor	2685.999	0.22E	0.4W	1%
R1004	Resistor	2685.999	0.22E	0.4W	1%
R1005	Resistor	2685.999	0.22E	0.4W	1%
R1006	Resistor	2685.999	0.22E	0.4W	1%
R1007	Resistor	2685.999	0.22E	0.4W	1%
R1008	Resistor	2685.999	0.22E	0.4W	1%
R1009	Resistor	2685.999	0.22E	0.4W	1%
R1010	Resistor	2713.097	10E	0.25W	5%
R1011	Resistor	2713.097	10E	0.25W	5%
R1012	Resistor	2713.401	15K	0.25W	5%
R1013	Resistor	2713.401	15K	0.25W	5%
R1014	Resistor, only series 1	2713.481	100k	0.25W	5%
R1015	Resistor	2713.321	2k2	0.25W	5%
R1016	Resistor	2713.241	330E	0.25W	5%
R1017	Resistor	2804.110	1k1	0.25W	1%
R1018	Resistor	2713.577	1M	0.4W	5%
R1019	Resistor	2713.241	330E	0.25W	5%
R1020	Resistor	2713.321	2k2	0.25W	5%
R1021	Resistor	2713.153	39E	0.25W	5%
R1022	Resistor	2713.577	1M	0.4W	5%
R1023	Resistor, only series 1	2804.121	1k21	0.25W	1%
	from series 2	2804.475	4k75	0.25W	1%
R1024	Resistor	2713.241	330E	0.25W	5%
R1025	Resistor	2804.100	1k	0.25W	1%
R1026	Resistor	2804.475	4k75	0.25W	1%
R1027	Resistor	2713.321	2k2	0.25W	5%
R1028	Resistor	2803.200	200E	0.25W	1%
R1029	Resistor	2804.475	4k75	0.25W	1%
R1030	Resistor	2804.475	4k75	0.25W	1%

* We advise to keep marked items in stock

item	description	ref. no.	electrical data		
			remarks		
R1031	Resistor	2713.641	4M7	0.4W	5%
R1032	Resistor	2713.481	100k	0.25W	5%
R1033	Resistor	2804.432	4k32	0.25W	1%
R1034	Resistor	2713.321	2k2	0.25W	5%
R1035	Resistor	2713.169	56E	0.4W	5%
R1036	Resistor	2713.193	100E	0.25W	5%
R1037	Resistor	2804.475	4k75	0.25W	1%
R1038	Resistor	2713.097	10E	0.25W	5%
R1039	Resistor	2713.065	4E7	0.25W	5%
R1040	Resistor	2713.193	100E	0.25W	5%
R1041	Resistor	2713.433	33k	0.25W	5%
R1042	Resistor	2713.433	33k	0.25W	5%
R1043	Resistor	2713.481	100k	0.25W	5%
R1044	Resistor	2704.273	680E	1W	5%
R1045	Resistor	2713.417	22k	0.25W	5%
R1046	Resistor	2713.361	5k6	0.4W	5%
R1047	Resistor	2713.481	100k	0.25W	5%
R1048	Resistor	2713.417	22k	0.25W	5%
R1049	Resistor	2713.193	100E	0.25W	5%
R1050	Resistor	2713.385	10k	0.25W	5%
R1051	Resistor	2713.241	330E	0.25W	5%
R1052	Resistor (only series 1)	2803.182	182E	0.25W	1%
R1053	Resistor	2713.385	10k	0.25W	5%
R1054	Resistor	2713.529	330k	0.4W	5%
R1055	Resistor	2713.529	330k	0.4W	5%
R1056	Resistor	2804.100	1k	0.25W	1%
R1057	Resistor	2713.529	330k	0.4W	5%
R1058	Resistor	2804.475	4k75	0.25W	1%
R1059	Resistor	2804.475	4k75	0.25W	1%
R1060	Resistor	2713.385	10k	0.25W	5%
R1061	Resistor	2804.100	1k	0.25W	1%
R1062	Resistor	2804.100	1k	0.25W	1%
R1063	Resistor	2804.100	1k	0.25W	1%
R1064	Resistor	2804.100	1k	0.25W	1%
R1065	Resistor	2804.110	1k1	0.25W	1%
R1066	Resistor	2804.121	1k21	0.25W	1%
R1067	Resistor	2804.100	1k0	0.25W	1%
R1068	Resistor	2804.475	4k75	0.25W	1%
R1069	Resistor	2713.481	100k	0.25W	5%
R1070	Resistor	2803.182	182E	0.25W	1%
R1071	Resistor	2713.593	1M5	0.4W	5%
R1072	Resistor	2713.257	470E	0.25W	5%
R1073	Resistor	2713.257	470E	0.25W	5%
R1074	Resistor	2713.257	470E	0.25W	5%
R1075	Resistor	2713.257	470E	0.25W	5%
R1076	Resistor	2713.265	560E	0.25W	5%
R1077	Resistor	2804.100	1k	0.25W	1%
R1078	Resistor	2804.100	1k	0.25W	1%
R1079	Resistor	2804.100	1k	0.25W	1%
R1080	Resistor	2713.281	820E	0.25W	5%

* We advise to keep marked items in stock

item	description	ref. no.	electrical data	remarks
R1081	Resistor	2804.100	1k	0.25W 1%
R1082	Resistor	2713.481	100k	0.25W 5%
R1083	Resistor	2713.209	150E	0.25W 5%
R1084	Resistor	2713.209	150E	0.25W 5%
R1085	Resistor, from series 3	2713.329	2k7	0.4W 5%
R1086	Resistor, from series 4	2713.097	10E	0.4W 5%
R1087	Resistor, from series 4	2713.097	10E	0.4W 5%
R1088	Resistor, from series 4	2713.097	10E	0.4W 5%
R1089	Resistor, from series 2	2713.481	100k	0.25W 5%
RA1001	Resistor Array	2520.823	RDL 8 x 10k,	2%
RA1002	Resistor Array	2520.877	RDL 8 x 20k,	2%
RA1003	Resistor Array	2520.856	RDL 8 x 4k7,	2%
RA1004	Resistor Array	2520.856	RDL 8 x 4k7,	2%
RA1005	Resistor Array	2520.877	RSL 9 x 20k,	2%
RA1006	Resistor Array	2520.820	RSL 9 x 100k,	2%
RE1001 *	Relay	2620.708	SDS, S2	12V
RE1002	Relay	2620.708	SDS, S2	12V
S1001 *	Switch, mode selector	2601.391		
ST1 - ST4	Pin strip	2524.656	2p (supplied on strip of 25 pins)	
T1001 *	Transistor	2562.620	BUZ72A	
T1002	Transistor	2562.620	BUZ72A	
T1003 *	Transistor	2562.533	BC337	
T1004	Transistor	2562.533	BC337	
T1005 *	Transistor	2562.444	BC327	
T1006	Transistor	2562.444	BC327	
T1007	Transistor	2562.533	BC337	
T1008 *	Transistor	2562.613	VN2222	
T1009	Transistor	2562.613	VN2222	
T1010 *	Transistor	2562.619	BUZ71A	
T1011	Transistor	2562.613	VN2222	
T1012	Transistor	2562.619	BUZ71A	
T1013	Transistor	2562.619	BUZ71A	
T1014	Transistor	2562.533	BC337	
T1015	Transistor	2562.444	BC327	
T1016	Transistor	2562.533	BC337	
T1017	Transistor	2562.620	BUZ72A	
T1018	Transistor	2562.533	BC337	
T1019	Transistor	2562.533	BC337	
T1020	Transistor	2562.533	BC337	

* We advise to keep marked items in stock

item	description	ref. no.	electrical data remarks
T1021	Transistor	2562.533	BC337
T1022	Transistor	2562.533	BC337
T1023	Transistor	2562.533	BC337
T1024	Transistor	2562.533	BC337
T1025	Transistor	2562.533	BC337
T1026	Transistor	2562.444	BC327
T1027	Transistor	2562.444	BC327
T1028	Transistor	2562.621	BSS89
TP1 - TP23			
	Solder tag	2590.037	2.8x0.8mm
TR1001	* Transformer	2680.658	
TR1002	* Transformer	2680.657	
TR1003	* Transformer	2680.641	
X1001	* X-tal	2596.050	8MHz

* We advise to keep marked items in stock.

item	description	ref. no.	electrical data	remarks
BATTERY CHARGER ENC 12-Pb (LG701)				
Components are drawn in the diagram and the lay-out without the prefix "800"				
e.g. R8003 is drawn as R3				
800	* Battery charger, complete	3444.294	110V, 50 - 60Hz (USA)	
		3444.295	220V, 50 - 60Hz (IEC)	
		3444.296	240V, 50 - 60Hz (UK)	
801	P.C. Board	on demand		
802	Housing, upper part	on demand		
803	Housing, bottom part	on demand		
804	Screws (3x)	on demand		
805	* Mains cable, with USA - plug	on demand		
	with IEC - plug	2570.116		
	with UK - plug	on demand		
806	* Charging lead with plug	2570.115		
-P.C. Board-				
C8001	Capacitor	on demand	1000uF	
C8003	Capacitor	on demand	3u3	
C8004	Capacitor	on demand	100nF	
C8005	Capacitor	on demand	1uF	
D8001	Diode	on demand	1N4001	
D8002	Diode	on demand	1N4001	
D8003	Diode	on demand	1N4001	
D8004	Diode	on demand	1N4001	
D8006	Diode	2563.095	1N914	
D8007	Diode, zener 5.1V	2563.254	ZPD5.1	
D8008	Diode	2563.095	1N914	
IC8001	Integrated Circuit	2518.009	UA723	
P8001	Potentiometer, trimmer	on demand	1k 0.1W	
P8002	Potentiometer, trimmer	on demand	1k 0.1W	
R8001	Resistor	2713.193	100E 1/4W 5%	
R8002	Resistor	2701.001	1E 1W 1%	
R8003	Resistor	2803.560	560E 1/4W 1%	
R8005	Resistor	2803.560	560E 1/4W 1%	
R8007	Resistor	2713.361	5k6 1/4W 5%	
R8009	Resistor	2713.369	6k8 1/4W 5%	
R8012	Resistor	2713.337	3k3 1/4W 5%	
R8013	Resistor	2713.577	1M 1/4W 5%	
R8014	Resistor	2805.150	15k 1/4W 1%	
R8015	Resistor	2713.385	10k 1/4W 5%	
R8016	Resistor	2804.221	2k2 1/4W 1%	
T8001	Transistor	on demand	2N6099	
T8002	Transistor	2562.444	BC327	
T8003	Transistor	2562.533	BC337	
TR8001	Transformer	on demand		

* We advise to keep marked items in stock

item	description	ref. no.	electrical data	remarks
<u>TREATMENT HEAD, 1MHz, small</u>				
501	Housing, main part, complete with lenses for contact indicator lamps	0434.322		
502	Cap	2994.315		
503	Indication plate	2079.586		
504	Lock ring, inner	2994.316		
505	O-ring	2132.429		
506	Housing, inner part	2994.314		
507	* Treatment surface with X-tal	0434.805		
508	Seal	2135.231		
509	* Cable, length 1.7m (standard)	0434.311		green grommet
	Cable, length 3.0m	0434.315		green grommet
511	Contact ring	0165.992		
512	Contact stift (2x)	2615.068		
513	Contact stift holder (2x)	2615.069		
515	LED holder	2994.317		
520	Grommet, green	6779.775		
PL1	Plug	2524.842	7p	
R5	Resistor	2803.392	392E 1/W	1%
<u>-P.C. Board-</u>				
PR5	* P.C. Board 5, complete	0434.671		
C5001	Capacitor	2581.410	10n 63V	
CN21	Connector	2590.039	faston tab 2.8x0.8	
CN22	Connector	2524.837	6 pins	
D5001	Diode	2563.312	AA144	
L5001	Coil	2670.066	100u	
LE5001	LED, red	2562.396	SLH-56-VT3	
LE5002	LED, red	2562.396	SLH-56-VT3	
P5001	Potentiometer, trimmer	2639.372	5k 1W	
P5002	Potentiometer, trimmer	2639.270	1k 1W	
R5001	Resistor	2713.289	1k 1/4W	5%
R5002	Resistor	2713.289	1k 1/4W	5%

* We advise to keep marked items in stock

item	description	ref. no.	electrical data	remarks
<u>TREATMENT HEAD, 1MHz, large</u>				
601	Housing, main part, complete with lenses for contact indicator lamps	0434.321		
602	Cap	2994.315		
603	Indication plate	2079.585		
604	Lock ring, inner	2994.316		
605	O-ring	2132.429		
606	Housing, inner part	2994.314		
607	* Treatment surface with X-tal	0434.804		
608	Seal	2135.232		
609	* Cable, length 1.7m (standard)	0434.310		red grommet
	Cable, length 3.0m	0434.314		red grommet
611	Contact ring	0434.300		
612	Contact stift, 3.9mm	2615.070		
613	Stift holder	2615.069		
614	Contact pin	2523.128		
615	LED-holder	2994.317		
620	Grommet, red	6779.776		
621	Cable, black	7600.112		1.7 meter
622	Grommet, transparant	6779.771		
623	Coupling nut	2102.161		PG7
624	Connector (housing)	2524.823		
625	Contact bush (6x)	2523.729		
PL1	Plug	2524.842		
-P.C. Board-				
PR6	* P.C. Board 6, complete	0434.670		
C6001	Capacitor	2581.410	10n	63V
CN21	Connector	2590.039	faston tab	2.8x0.8
CN22	Connector (male part)	2524.837	6 pins	
D6001	Diode	2563.312	AA144	
L6001	Coil	2670.066	100u	
LE6001	LED, red	2562.396	SLH-56-VT3	
LE6002	LED, red	2562.396	SLH-56-VT3	
P6001	Potentiometer, trimmer	2639.494	10K	1W
P6002	Potentiometer, trimmer	2639.270	1K	1W
R6001	Resistor	2713.289	1k	1/4W 5%
R6002	Resistor	2713.321	2k2	1/4W 5%
TR6001	Transformer	0434.502		

* We advise to keep marked items in stock

item	description	ref. no.	electrical data remarks
------	-------------	----------	----------------------------

ACCESSORIES

-Connection cables-

900	* Patient cable, complete,	3444.273	2-core
901	Plug	2524.404	5p, DIN, 270°
902	Plug, banana	2524.136	red
903	Plug, banana	2524.137	black
910	* Connection cable, complete, Sonopuls 464 - Vacotron 436	1436.800	
911	Plug	2523.404	5p, DIN, 270°
912	Plug	2523.404	5p, DIN, 270°

-Recommended tools-

930	* Dummy load for circuit adjustments	0434.802	
931	* Key wrench for treatment head	0434.801	
932	* Acoustical load	1417.802	
933	* Adaptor ring	0166.149	

* We advise to keep marked items in stock

N.B. Not all listed items are indicated on the photos and drawings

HOW TO ORDER SPARE PARTS

If you want to order spare parts, please mention the name and number of the apparatus (including serial and running number), number of components wanted, item number, description of component and reference number.
e.g.

For SONOPULS 464-1-01, 1x item S1, On/off switch, ref.no. 2601.263

By doing so, we can render optimal service in a quick and easy way.
For enquiries and orders please contact our Spare Parts Department.

According to approvals and safety standards, always use original components
if, for any reason, the unit has to be repaired.

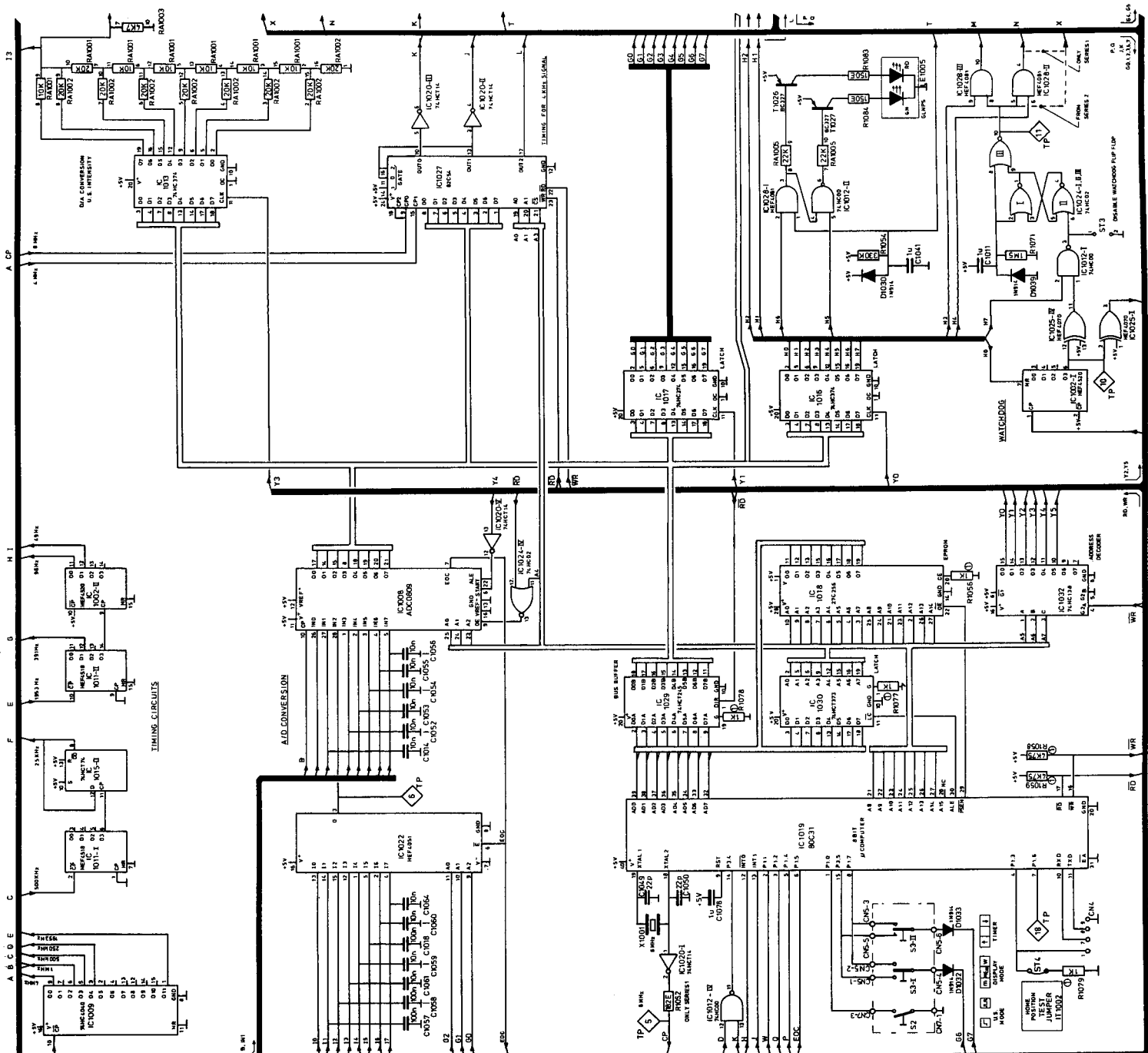

SUPPLY VOLTAGES INTEGRATED CIRCUITS

IC NO.	1	2	3	4	5	6	7	8	9	10	11	12	13	14	15	16	17	18	19	20
1001	100	100	100	100	100	100	100	100	100	100	100	100	100	100	100	100	100	100	100	100
1002	100	100	100	100	100	100	100	100	100	100	100	100	100	100	100	100	100	100	100	100
1003	100	100	100	100	100	100	100	100	100	100	100	100	100	100	100	100	100	100	100	100
1004	100	100	100	100	100	100	100	100	100	100	100	100	100	100	100	100	100	100	100	100
1005	100	100	100	100	100	100	100	100	100	100	100	100	100	100	100	100	100	100	100	100
1006	100	100	100	100	100	100	100	100	100	100	100	100	100	100	100	100	100	100	100	100
1007	100	100	100	100	100	100	100	100	100	100	100	100	100	100	100	100	100	100	100	100
1008	100	100	100	100	100	100	100	100	100	100	100	100	100	100	100	100	100	100	100	100
1009	100	100	100	100	100	100	100	100	100	100	100	100	100	100	100	100	100	100	100	100
1010	100	100	100	100	100	100	100	100	100	100	100	100	100	100	100	100	100	100	100	100
1011	100	100	100	100	100	100	100	100	100	100	100	100	100	100	100	100	100	100	100	100
1012	100	100	100	100	100	100	100	100	100	100	100	100	100	100	100	100	100	100	100	100
1013	100	100	100	100	100	100	100	100	100	100	100	100	100	100	100	100	100	100	100	100
1014	100	100	100	100	100	100	100	100	100	100	100	100	100	100	100	100	100	100	100	100
1015	100	100	100	100	100	100	100	100	100	100	100	100	100	100	100	100	100	100	100	100
1016	100	100	100	100	100	100	100	100	100	100	100	100	100	100	100	100	100	100	100	100
1017	100	100	100	100	100	100	100	100	100	100	100	100	100	100	100	100	100	100	100	100
1018	100	100	100	100	100	100	100	100	100	100	100	100	100	100	100	100	100	100	100	100
1019	100	100	100	100	100	100	100	100	100	100	100	100	100	100	100	100	100	100	100	100

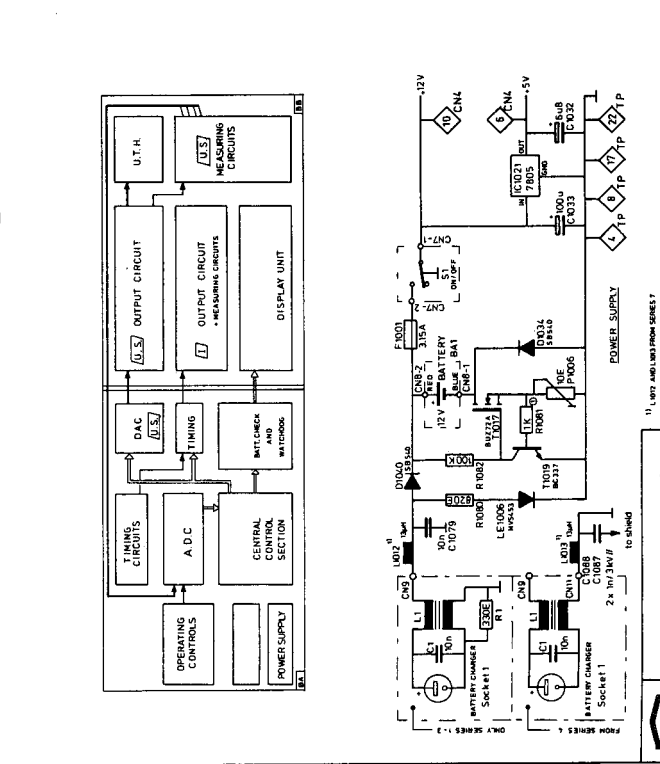
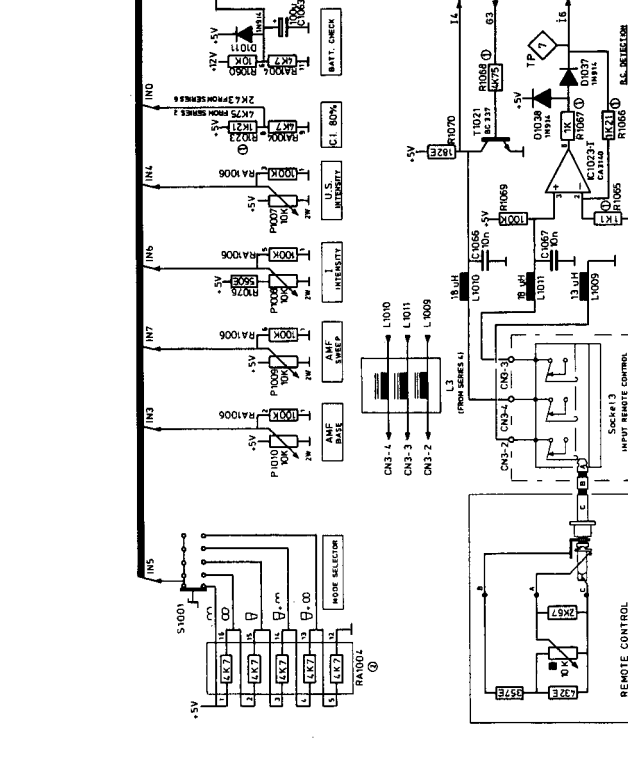





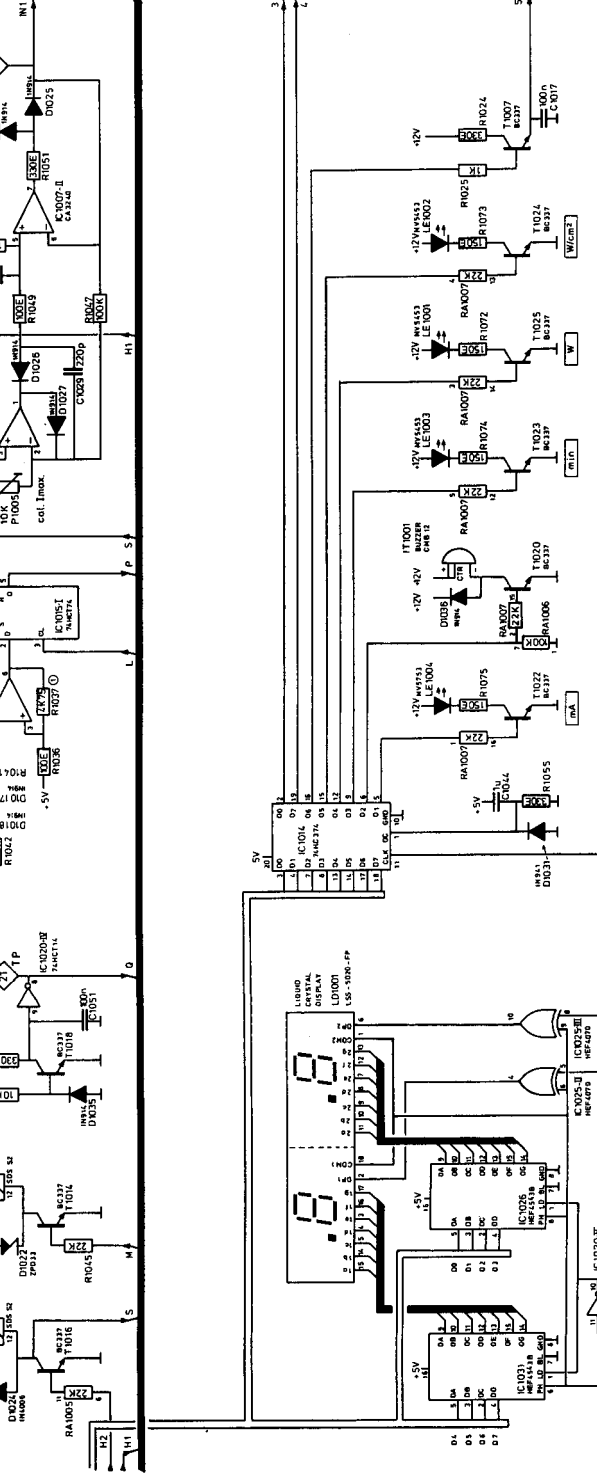
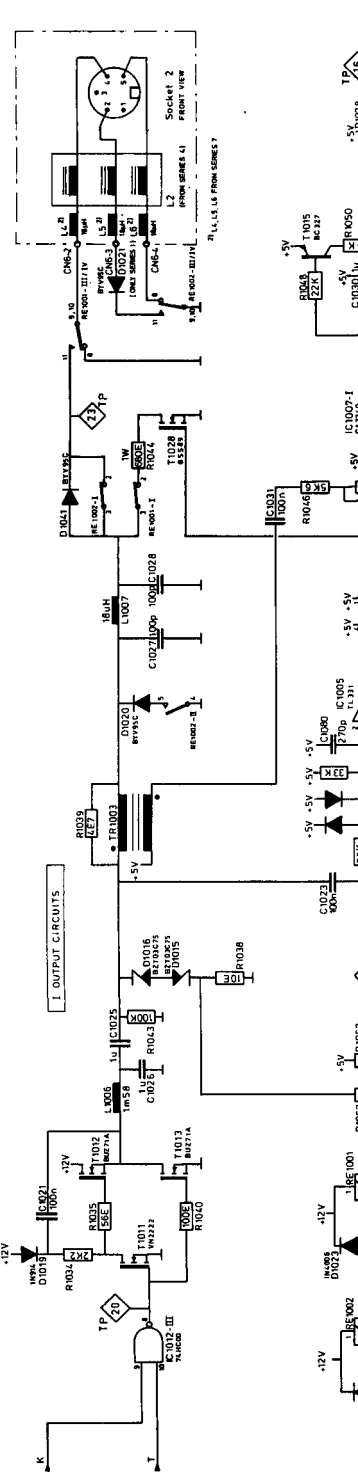
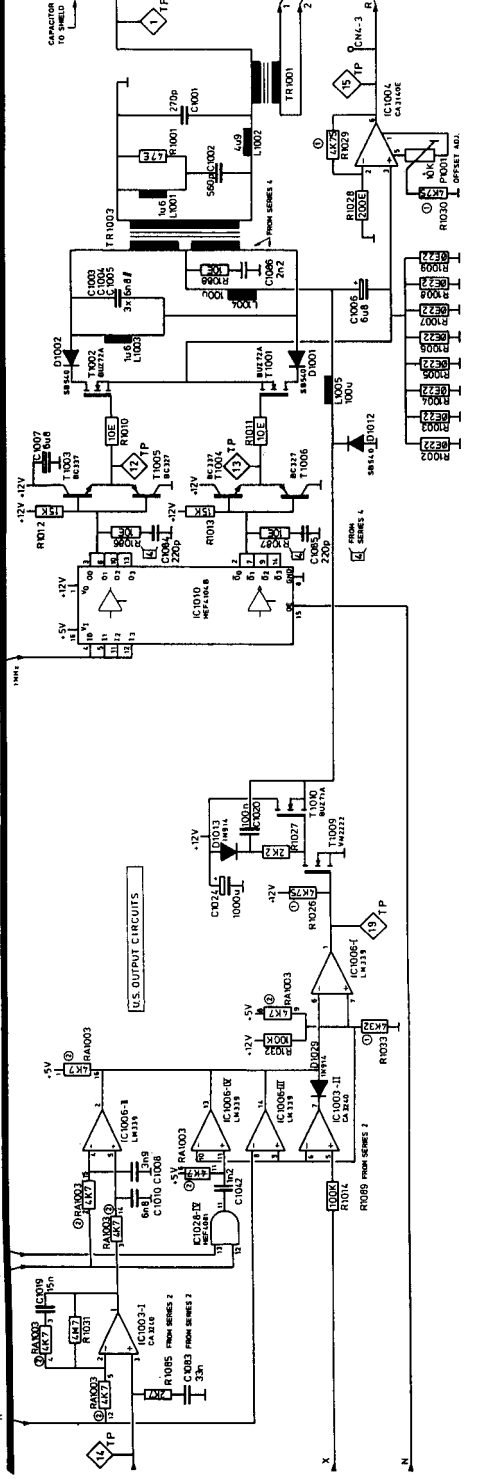
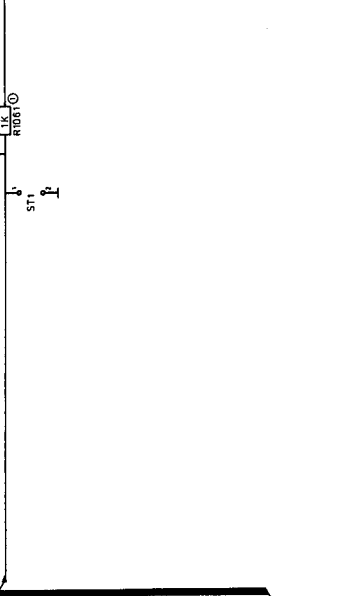
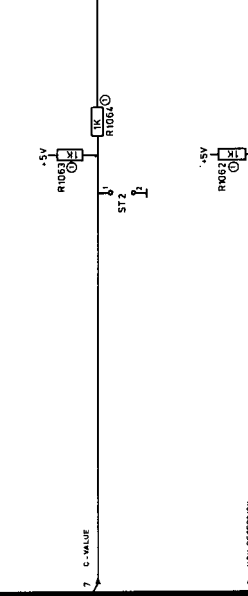
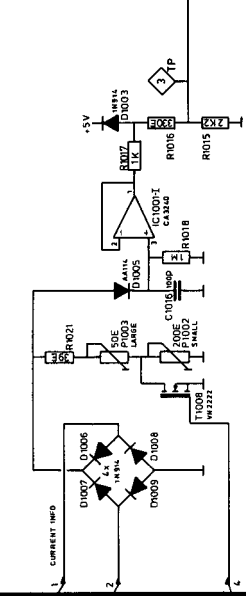
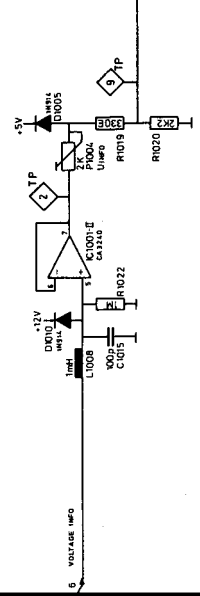
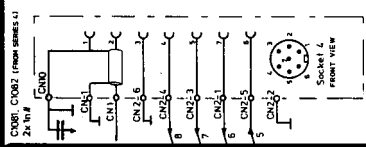
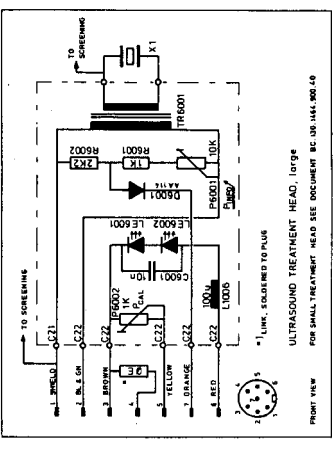

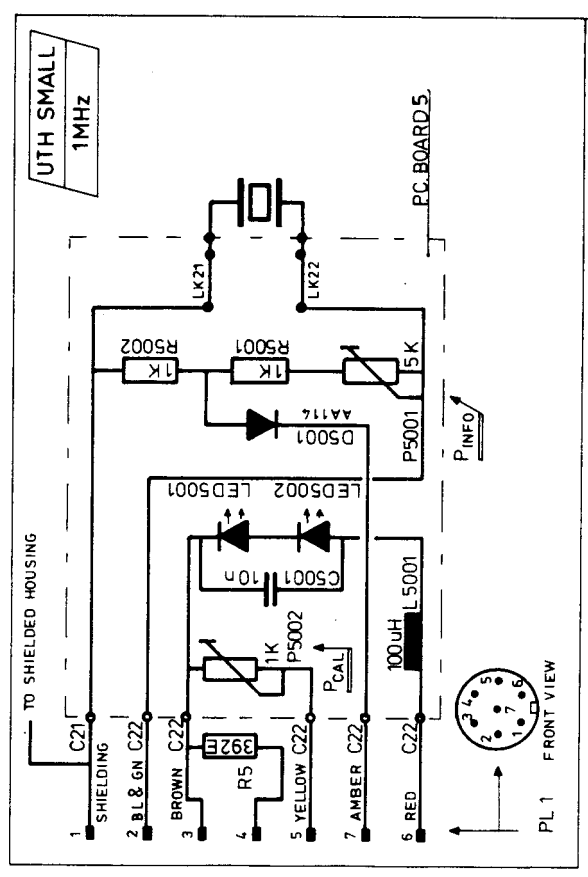
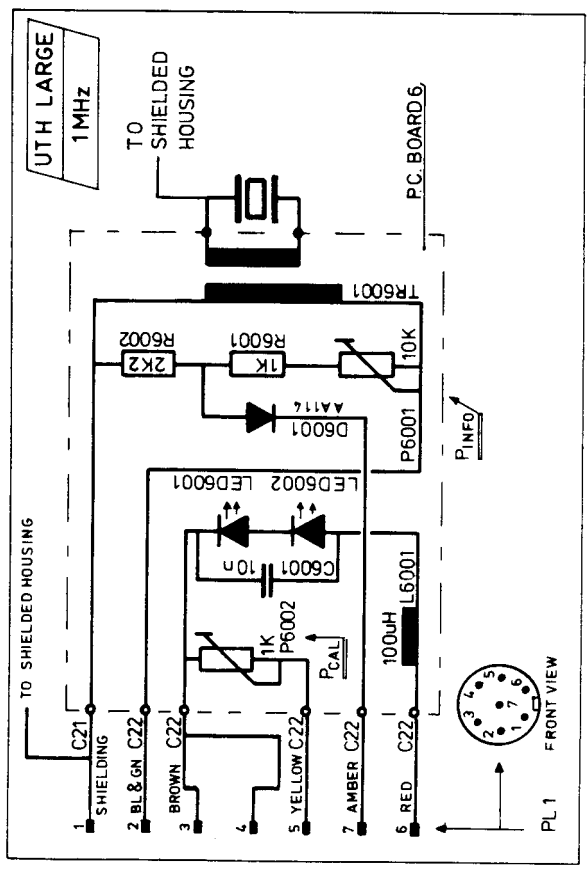

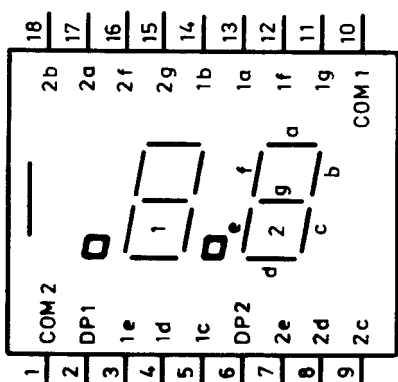
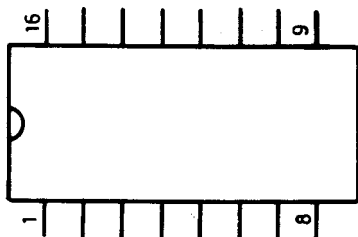
BA-130.1464.900.12







<p>LC - DISPLAY</p>  <p>top view</p>	<p>INTEGRATED CIRCUIT</p>  <p>top view</p>	<p>7805</p>  <p>IN GND OUT heat sink side pin view</p> <p>BUZ71A BUZ72A</p>  <p>G D S heat sink side PIN VIEW</p>	<p>BC327 BC337</p>  <p>E B C PIN VIEW</p> <p>VN2222</p>  <p>D G S PIN VIEW</p>	<p>BSS89</p>  <p>G D S PIN VIEW</p> <p>RESISTOR ARRAY</p> 
			<p>APPENDIX</p> <p>BD.130.1464.900 - 40</p>	

TECHNICAL INFO

MEDICAL DIVISION

T.I. 464 - 01 (page 1/2)

TITLE:

SOFTWARE MODIFICATION SERIES 5 (version 6.4)

DESCRIPTION:

The software has been modified to get a more reliable result from the selftest when the battery voltage is low (flashing green indicator). With software versions 6.1 and 6.3 it is possible that the Sonopuls gives fault number 18 without any circuit being defective.

Because the selftest has been changed please make the following corrections in your service manual:

Page 37:

"16" Peack picker or internal load (MF-output stage)

Defect in circuit for measuring the current intensity or defective internal load circuit.

Possible defects	Advised test routines
IC1007	
T1015	test 5
IC1016 (latch)	test 5
T1028	test 5
R1044	
RE1001(contact I)	

"17" Voltage monitoring circuit (MF-output stage)

This monitoring circuit is tested by driving the output stage to maximum output voltage (75V). When TP21 switches to logic 1 state then the monitoring circuit is o.k. Otherwise fault number 17 is displayed. During this test, T1016 is made conductive so the internal load resistor R1044 is switched off by T1028.

Possible defects	Advised test routines
D1015	
D1016	
T1018	
IC1020(IV)	
T1016	test 5
T1028	test 5

Page 38 (test 0):

Number	Fault in
16	Peack picker or internal load (MF-output stage)
17	Voltage monitoring circuit (MF-output stage)

INSTRUCTIONS:

Replace software versions 6.1 and 6.3 with version 6.4

CHANGE CLASSIFICATION:

Commencing date: march 1988

Carried out from series: 5

Perform immediately on all field units.

Perform routinely at next service call.

Perform only upon unit failure.

Information

Deleted components: IC1018, version 6.3, ref. no. 0464.703

New components: IC1018, version 6.4, ref. no. 0464.704

NOTES:

With the new software, a fault in the voltage monitoring circuit will result in fault number 17 instead of 18. Although test 18 is still operative it is unlikely that number 18 will appear as a fault number.

TECHNICAL INFO

MEDICAL DIVISION

T.I. 464 - 02 (page 1/1)

Title:

SONOPULS 464, US-OUTPUT POWER MODIFICATION (1.5W/cm²)

Description:

The ultra sound output power has been increased from 1W/cm² to 1.5W/cm². This modification has been realised by software only. The new EPROM version 6.5 also contains the old 6.4 program so that it is downwards compatible. The value of code resistor R1023 is decisive for the program version that is run. From series 6, R1023 has been changed from 4k75 to 2k43.

Change classification:

- Perform immediately on all field units.
- Perform routinely at next service call.
- Perform only upon unit failure.
- Information only.

Carried out from series :	6	
New components :	EPROM IC1018 version 6.5,	0464.705
	R1023, 2k43, 1%, 0.25W,	2804.243
	Item 20, indication plate,	2077.213
Deleted components :	EPROM IC1018 version 6.4,	0464.704
	R1023, 4k75,	2804.475
	Item 20, indication plate,	2077.180
Updated documents :	BA. 130.1464.900.11	
Our reference :	WV nr 0464.690-23/03 dd 9/6/1988	

Title:

SONOPULS 464, MODIFICATION HF-FILTERS L1 AND L2

Description:

When an extremely powerful HF-signal enters the battery charger circuit of the Sonopuls 464, the HF input filter L1 can overheat or even burn out. Such a situation can occur when a shortwave unit is operated within less than 2 meters distance from the Sonopuls unit and the battery charger. (The HF-signal is picked up by the charger lead via which it enters the Sonopuls unit.) The same is true for output filter L2 of the current output circuit. A powerful HF-field can cause overheating of the coil.

From series 7, both filters have been modified to prevent the above problems. Two coils are added to the charger circuit as new components. Three coils are added to the current output circuit.

Change classification:

- Perform immediately on all field units.
- Perform routinely at next service call.
- Perform only upon unit failure.
- Information only.

Carried out from series : 7

New components :	L1012, coil 13uH,	2670.111
	L1013, coil 13uH,	2670.111
	L4, coil 18uH,	2670.059
	L5, coil 18uH,	2670.059
	L6, coil 18uH,	2670.059

Updated documents : BA.130.1464.900.12
BB.130.1464.900.11

Our reference : WV no. 0464.690.23/05 dd 07/09/88
WV no. 0464.603.41/01 dd 07/09/88

New circuit diagrams from series 7:

(BA.130.1464.900.12)

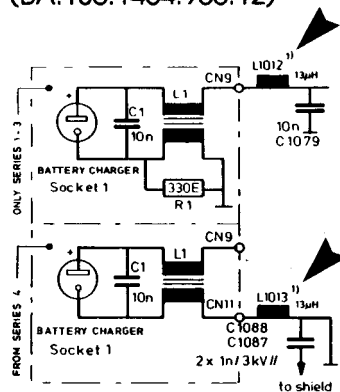

(BB.130.1464.900.11)

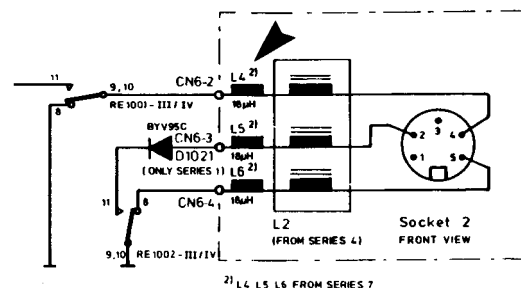

New PCB-layout from series 7:

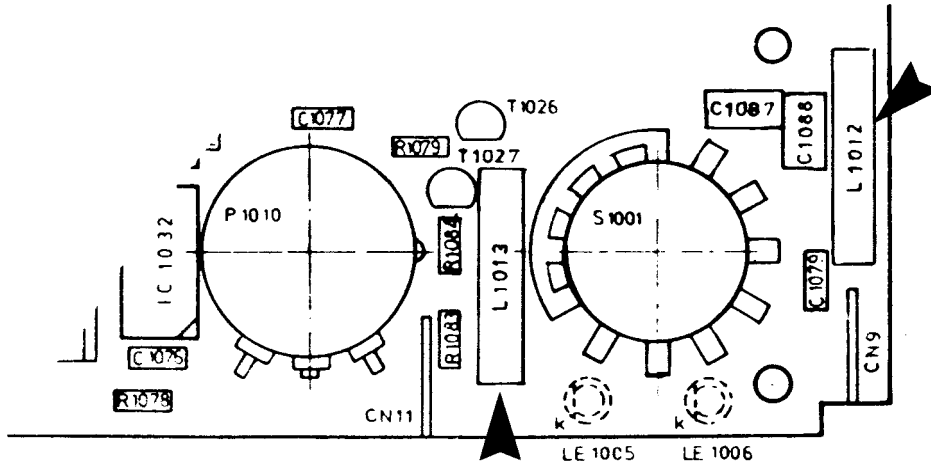

TECHNICAL INFO

MEDICAL DIVISION

T.I. 464 - 04 (page 1/1)

Subject:

SONOPULS 464, TIMER MODIFICATION

Description:

On request of many Sonopuls 464 users, the maximum treatment time has been extended from 15 to 30 minutes. This is true for treatments with medium frequency currents as well as for ultrasound treatments.

From series 7, the new software version 6.6 is installed. Note that when software version 6.6 is installed in former series of Sonopuls 464 units, the timer is automatically modified into 30 minutes maximum set value.

Change classification:

- Perform immediately on all field units.
- Perform routinely at next service call.
- Perform only upon unit failure.
- Information only.

Carried out from series : 7
New components : IC1018, EPROM version 6.6, 0464.706
Our reference : WV no. 0464.690.23/06 dd 07/09/88

Service Information

SONOPULS 464, front panel colour change.

Front panel colour

The colour of the front panel of all 4-series equipment has been changed according to the table below:

- | | |
|--|----------|
| 1. Electro therapy equipment | : Blue |
| 2. Ultra sound equipment (and combination equipment) | : Green |
| 3. HF equipment | : Red |
| 4. Myofeedback equipment | : Purple |
| 5. All other types of equipment | : Yellow |

As a result of this, the colour of the frontpanel of the Sonopuls 464 has been changed to GREEN.

The spare part number of the new frontpanel is: 0464.803.

Please add this page to your service manual.

Change classification

- Perform immediately on all field units.
- Perform routinely at next service call.
- Perform only upon unit failure.
- Information only

Commencing date:	August 1992	
Carried out from series:	NA	
New components:	Front panel (new)	Part no.: 0464.803
Deleted components:	Front panel (old)	Part no.: 2077.180
Our reference: :	NA	

Service Information

SONOPULS 464, CE marking

The Sonopuls 464 equipment produced after March 1996 is sold in the European union with CE marking. The Sonopuls 464 complies with all requirements of the EMC Directive (89/336/EEG and 92/31/EEG) using the transition period for the Medical Device Directive (93/42/EEG).

The CE marked equipment can be identified by the following symbol at the rear side of the housing.



For the Sonopuls 464 with CE marking the following parts have been added:

- Wiring with Connectors	part number	0464.604
- Wiring with Connectors	part number	0464.607
- Wiring with Connectors	part number	0464.612
- Wiring with Connectors	Part number	0464.613
- Filter PC Board set:	part number:	0464.640

This set contains two filter PC Boards, wiring is included. For location of the filter PC Boards inside the Sonopuls 464 housing see figure 1 at the back side of this service information.

Please add this service info to appendix C of your service manual.

Change classification

- Perform immediately on all field units.
- Perform routinely at next service call.
- Perform only upon unit failure.
- Information only

Commencing date:	March 1996
Carried out from series:	NA
New components:	0464.604 (Wiring with Connectors) 0464.607 (Wiring with Connectors) 0464.612 (Wiring with Connectors) 0464.613 (Wiring with Connectors) 0464.640 (Set Filter PC Boards wit wiring)
Deleted components:	NA
Our reference: :	WV 1463.00-60/10

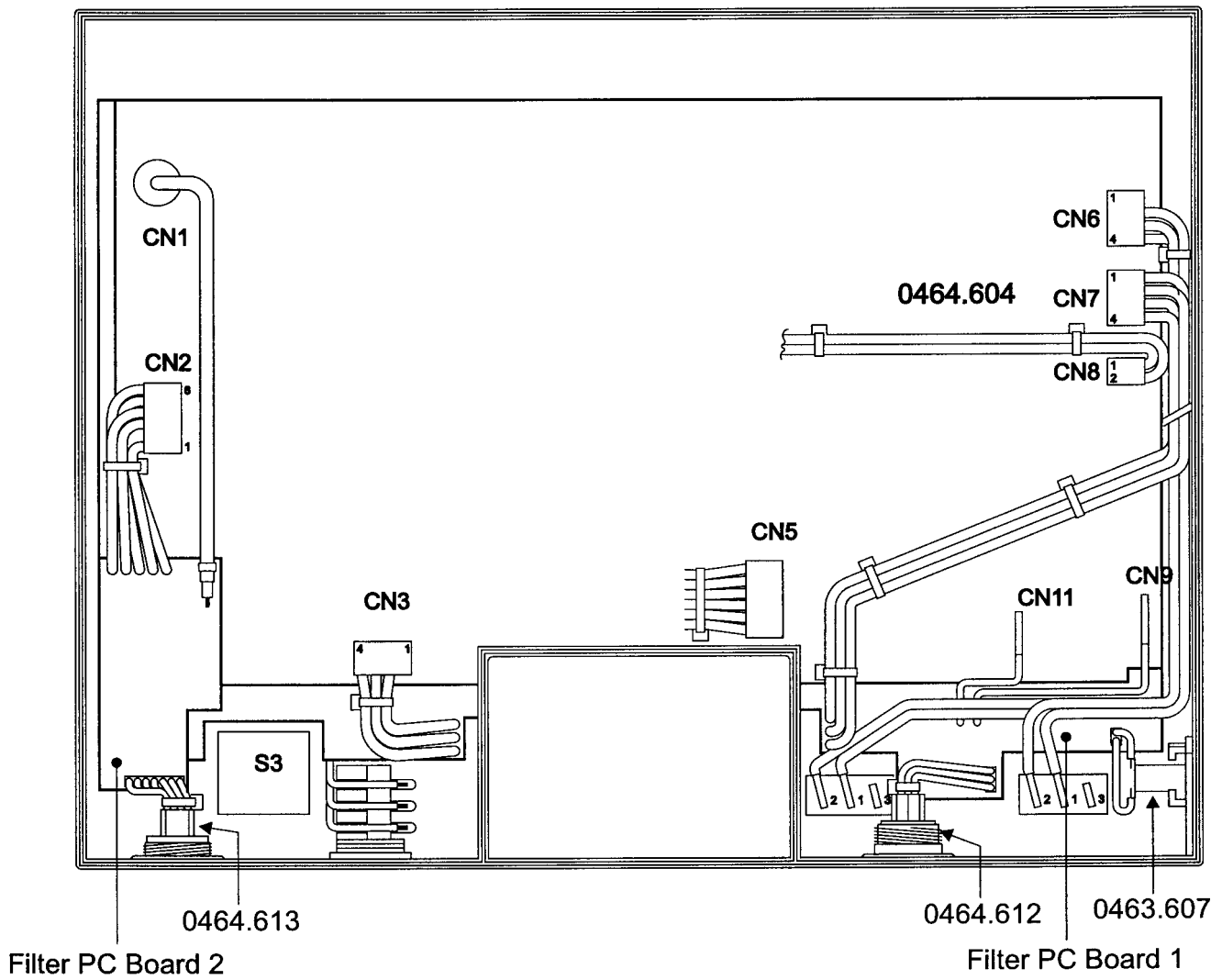

Figure. 1 Location of the EMI suppression components and PC Boards



Service Information

SONOPULS 464, adjustment CE marked equipment

The Sonopuls 464 equipment produced after March 1996 is sold in the European union with CE marking. Due to the EMI screening modifications the adjustment of the Sonopuls 463 has been changed. The adjustment procedure on page 49 has been changed as follows:

<u>Test 77:</u>	Check/adjust the ultrasound output power and display (for UTH large)
WAIT	Wait for the buzzer.
TP2	Connect a voltmeter (10V range) to TP2 (+) and
TP17	TP17 (ground).
CHECK	Check that the meter reading is between 5.45V and 5.55V (<i>new, changed values</i>), otherwise, readjust P1003 and P1004 (see below).
CHECK	Check that the display indicates a reading between 1.97 and 2.03, otherwise, readjust P1003 and P1004 (see below).
P1003	Adjust with P1003 (linfo-large) the voltage at TP2 to 5.50V (<i>new, changed value</i>).
P1004	Adjust with P1004 (Uinfo) the value on the <u>display</u> to '2.00'(see note below).

NOTE: the most significant bit is in this test indicated by the display mode LEDs:

- 0 LEDs 'on': read 0. (- -)
- 1 LED 'on': read 1. (- -)
- 2 LEDs 'on': read 2. (- -)

The value between the brackets (- -) is the value shown on the display.

CALL THE NEXT ADJUSTMENT ROUTINE ('88') BY PRESSING THE TIME SETTING SWITCH TO 'UP'

Test 88: Check/adjust the ultrasound output power (for UTH small)

WAIT	Wait for the buzzer.
TP2	Connect a voltmeter (10V range) to TP2 (+) and
TP17	TP17 (ground).
CHECK	Check that the meter reading is between 2.57V and 2.63V (<i>new, changed values</i>), otherwise, readjust P1002 (see below).
P1002	Adjust with this control (linfo-small) the voltage at TP2 to 2.60V (<i>new, changed value</i>).

ADJUSTMENTS OF TREATMENT UNIT COMPLETED

Please add this service info to appendix C of your service manual.

Change classification

- Perform immediately on all field units.
- Perform routinely at next service call.
- Perform only upon unit failure.
- Information only

Commencing date:	March 1996
Carried out from series:	NA
New components:	NA
Deleted components:	NA
Our reference: :	WV 1464.772-70/01

Service Information

Sonopuls 464, equipment adjustment new battery charger

Charger type 3444295, new type.

The Sonopuls 464 is currently sold with a new type of battery charger. The charger which is used is a so called pulsed current charger. The battery charging current adjustment in the service manual is meant for the "old" DC battery charger. The adjustment procedure for the new charger is as follows:

Adjustment of the battery charging current

- Switch off the Sonopuls 464 and disconnect the battery charger.
- Open the unit
- Disconnect CN5 (battery connector) from the PC Board.
- Connect a resistor of 1.0Ω (5%) 1W. in series with the positive wire of the battery at connector CN5. The positive wire is found at CN5-2, the negative at CN5-1.
- Connect an oscilloscope parallel to the resistor of 1.0Ω to measure the flowing current, settings: 100mV/div.
2ms/div.
- Connect the battery charger, do **not** switch on the unit.
- Adjust potentiometer P6001 until the maximum of the signal equals to 400mV. see figure 1 for waveform with the Sonopuls 464 unit switched off,
- Switch on the unit and see figure 2 for waveform with the Sonopuls 464 switched on.
- Switch off the unit and disconnect the battery charger.
- Disconnect the oscilloscope and the resistor.
- Reconnect the battery.
- Close the unit.

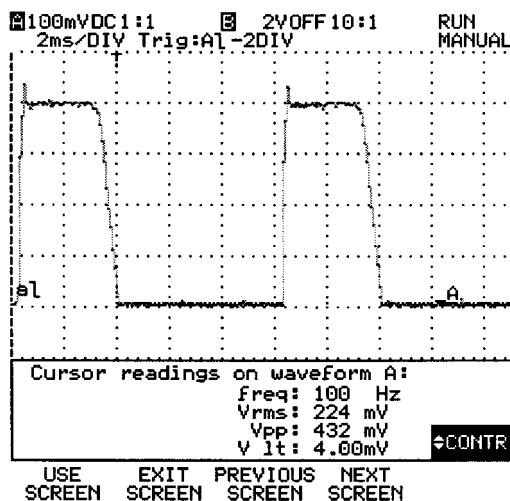

Figure1 Waveform $t=10ms$, $U=400mV$
Sonopuls 464 switched off.

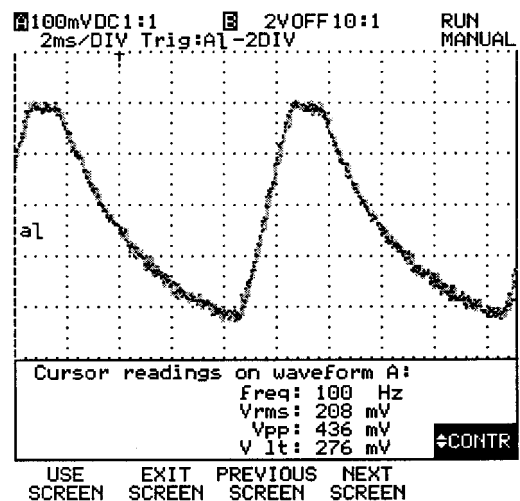

Figure2 Sonopuls 464 switched on.

Note: When replacing the old type battery charger of the 4-series portable equipment by a charger of the new type, it is advised to adjust the charging circuit of the unit as above.

Please add this service info to appendix C of your service manual.

Change classification

- Perform immediately on all field units.
- Perform routinely at next service call.
- Perform only upon unit failure.
- Information only

Commencing date:	February 1998
Carried out from series:	NA
New components:	NA
Deleted components:	NA
Our reference: :	HvD / EJH 980121 / LH intern98075-02



**Enraf
Nonius**

Enraf-Nonius B.V.

Röntgenweg 1, 2624 BD Delft

P.O. Box 810, 2600 AV Delft

The Netherlands

Tel.: +31 (0) 15 269 84 00

Fax: +31 (0) 15 256 16 86

Trade Register No.: 260.30.375