

SCHEMATIC DIAGRAM,
MONITOR PCB
54805-01841

REV. H SHEET 2 OF 2

13. CAPACITOR VALUES ARE 50V.
14. RESISTOR VALUE EXPRESSED IN OHMS AND ARE 5% 1/4W.
15. REF ASSEMBLY 51000-00676.

TUBE AND NO.	P/L ITEM NO.	TUBE SIZE	TUBE MATERIAL	FROM COMPONENT	TO COMPONENT	TUBE AND NO.	P/L ITEM NO.	TUBE SIZE	TUBE MATERIAL	FROM COMPONENT	TO COMPONENT
1	1	1/8 OD X 15.0	NYLON	INLET MANIFOLD	X-DUCER MANIFOLD	24	5	1/8 X 1.5	SILICONE	TEE	PROX. PORT
2	1	1/8 X 10.0	NYLON	INLET MANIFOLD	X-DUCER MANIFOLD	25	5	1/8 X 1.0	SILICONE	E.V. SOL.	TEE
3	5	1/8 X 3.5	SILICONE	AIR REG.	TEE	26	5	1/8 X 3.0	SILICONE	TEE	E.V. SOL.
4	5	1/8 X 3.5	SILICONE	O ₂ RELAY	TEE	27	5	1/8 X 3.0	SILICONE	E.V. SOL.	E. V.
5						28	5	1/8 X 1.0	SILICONE	E.V. REG.	TEE
6						29	3	1/8 X 1.0	VINYL	TEE	E.V. REG.
7	9	3/8 X 10.5	VINYL	BLENDER	ACCUMULATOR	30	5	1/8 X 10.5	SILICONE	TEE	.030 ORIFICE
8	9	3/8 X 7.0	VINYL	AIR REG.	BLENDER	31	5	1/8 X 3.5	SILICONE	EPI SWITCH	E.V. SOL.
9	3	1/8 X 18.0	VINYL	AIR REG.	SHUT-OFF SOL.	32	3	1/8 X 12.0	VINYL	FLOW VALVE	X-DUCER
10	9	3/8 X 12.0	VINYL	O ₂ RELAY	BLENDER	33	5	1/8 X 5.5	SILICONE	ZERO ADJ. SOL.	TEE
11	5	1/8 X 8.0	SILICONE	TEE	SOPR	34	5	1/8 X 5.0	SILICONE	SOPR	TEE
12	3	1/8 X 13.0	VINYL	SHUT-OFF VALVE	TEE	35	5	1/8 X 11.0	SILICONE	SOPR	XDCR MACH PRESSURE
13	9	3/8 X 17.5	VINYL	ACCUMULATOR	FLOW VALVE	36	5	1/8 X 1.0	SILICONE	TEE	.006 ORIFICE
14	11		SILICONE	FLOW VALVE	SOPR	37	5	1/8 X 2.0	SILICONE	TEE	.012 ORIFICE
15	7	1/4 X 1.0	VINYL	REDUCER	JET PUMP	38	5	1/8 X 5.0	SILICONE	TEE	TEE
16	5	1/8 X 17.0	SILICONE	NEEDLE VALVE	REDUCER	39	7	1/4 X 1.0	VINYL	NEB. REG.	REDUCER
17	9	3/8 X 1.25	VINYL	JET PUMP	SOPR	40	5	1/8 X 2.0	SILICONE	TEE	TEE
18	3	1/4 X 1.0	VINYL	JET PUMP	REDUCER	41	5	1/8 X 1.0	SILICONE	TEE	SOPR
19	3	1/8 X 13.0	VINYL	TEE	NEEDLE VALVE	42	5	1/8 X 1.0	SILICONE	TEE	TEE
20	5	1/8 X 10.0	SILICONE	TEE	SOPR	43	3	1/8 X 16.0	VINYL	REDUCER	BLEED SOL. (IN)
21	7	1/4 X 2.5	VINYL	ACCUMULATOR	NEB. REG.	44	5	1/8 X 7.0	SILICONE	TEE	BLEED SOL. (OUT)
22	7	1/4 X 5.0	VINYL	NEB. REG.	NEB. SOL.	45	5	1/8 X 6.5	SILICONE	TEE	TEE
23	5	1/8 X 4.5	SILICONE	REDUCER	TEE	46	5	1/8 X 1.0	SILICONE	.012 ORIFICE	TEE
						47	5	1/8 X 1.0	SILICONE	.006 ORIFICE	TEE
						48	5	1/8 X 1.0	SILICONE	.030 ORIFICE	PROX GAUGE

16. TUBING THAT IS PART OF THE INLET MANIFOLD ASSY IS NOT SHOWN FOR CLARITY.

15. TUBING AND TEES SHOWN BUT NOT IDENTIFIED ARE PART OF THE EPI PCB ASSEMBLY.

14. TIE-WRAP ALL VINYL TUBING CONNECTIONS.

13. DELETED.

12. SEE TUBE LIST FOR P/L ITEMS 1,2,5,7,9 & 11.

11. UNLESS NOTED OTHERWISE, DIAMETERS ARE INSIDE DIAMETERS.



TUBING INSTALLATION,
PNEUMATIC

51000-08592

REV. H

SHEET 1 OF 2

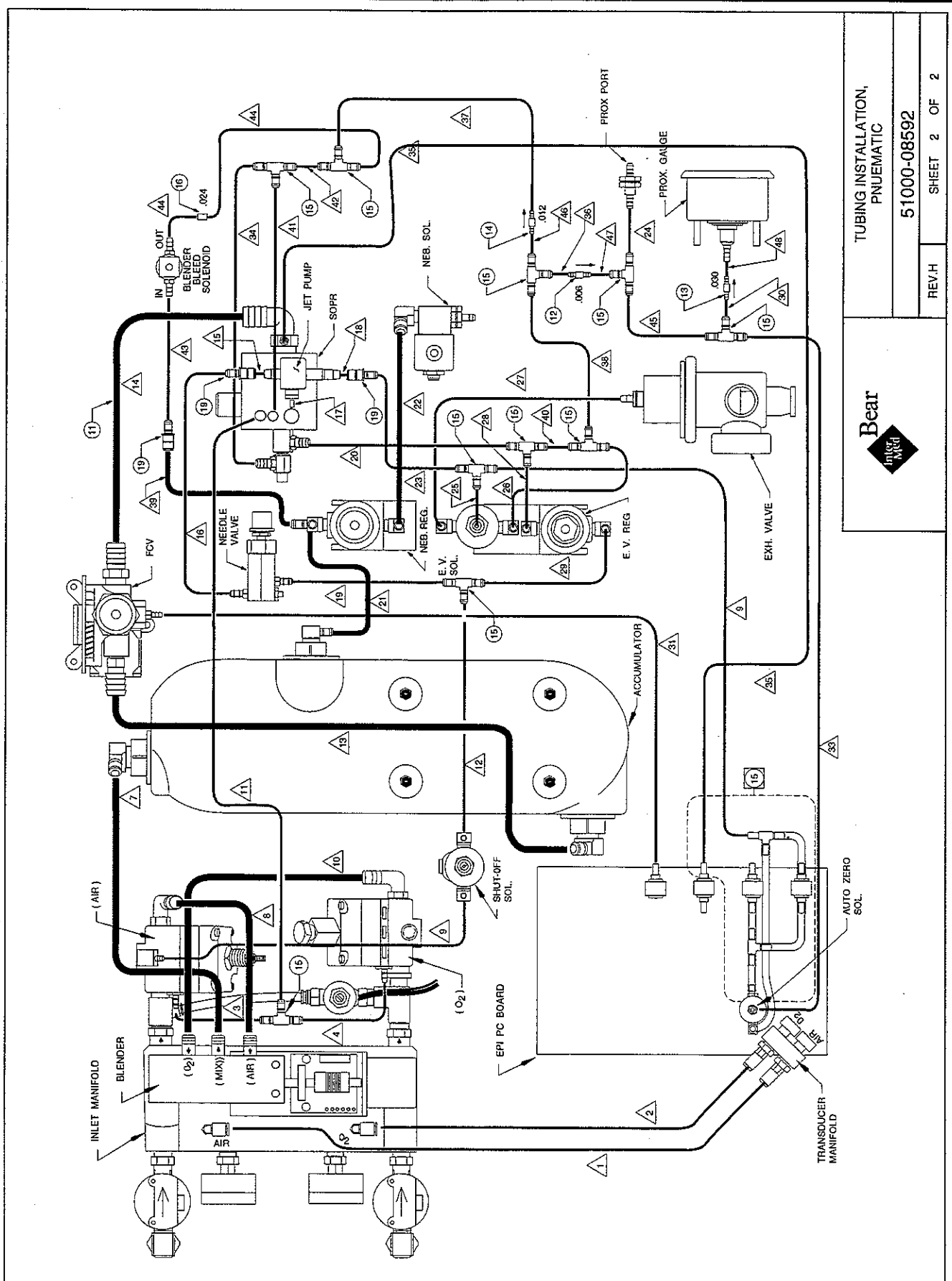

TUBING INSTALLATION,
PNEUMATIC

51000-08592

REV.H SHEET 2 OF 2



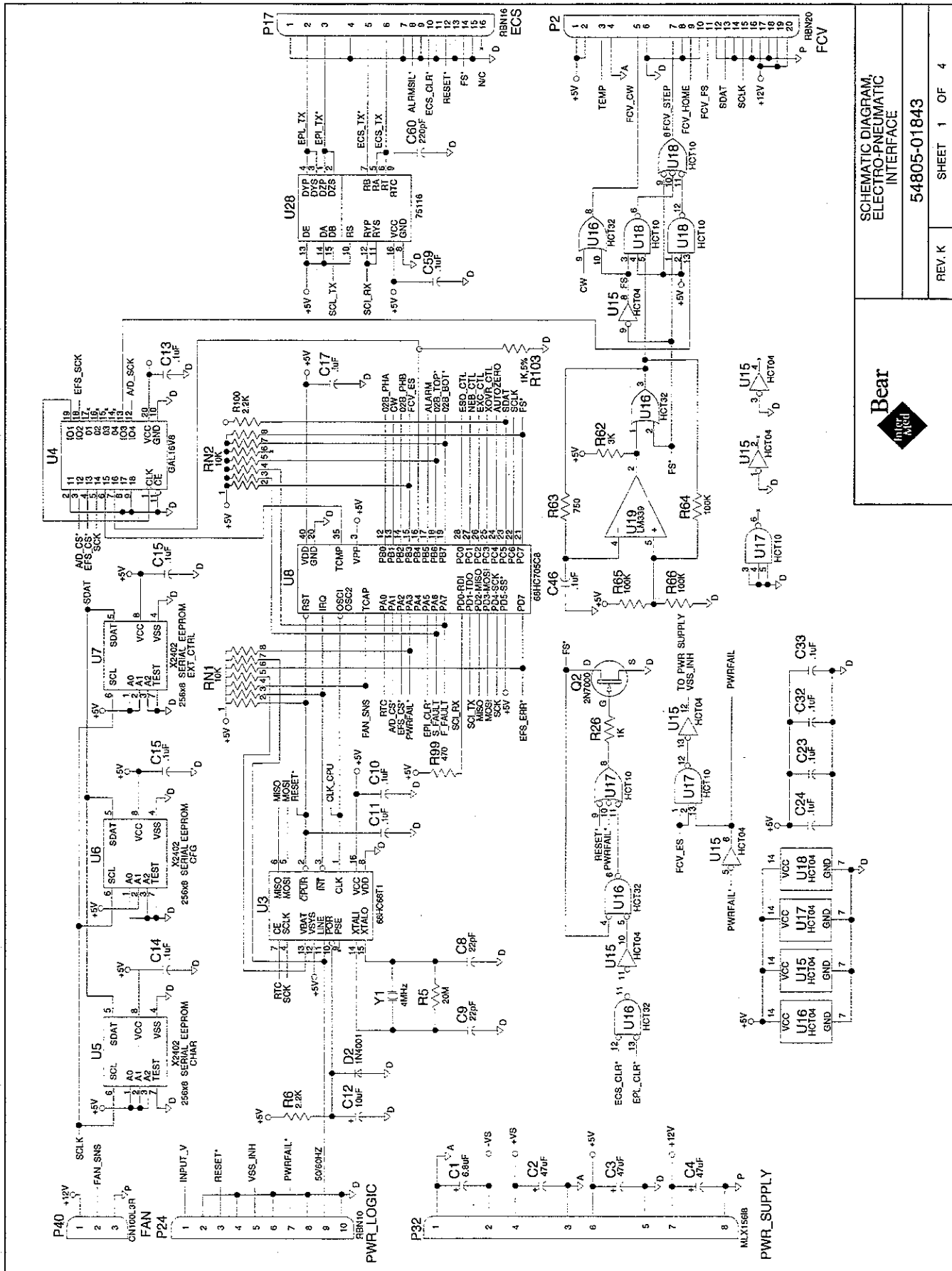

SCHEMATIC DIAGRAM
ELECTRO-PNEUMATIC
INTERFACE

54805-01843

REV. K

SHEET 1 OF 4

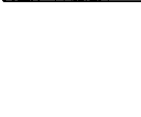

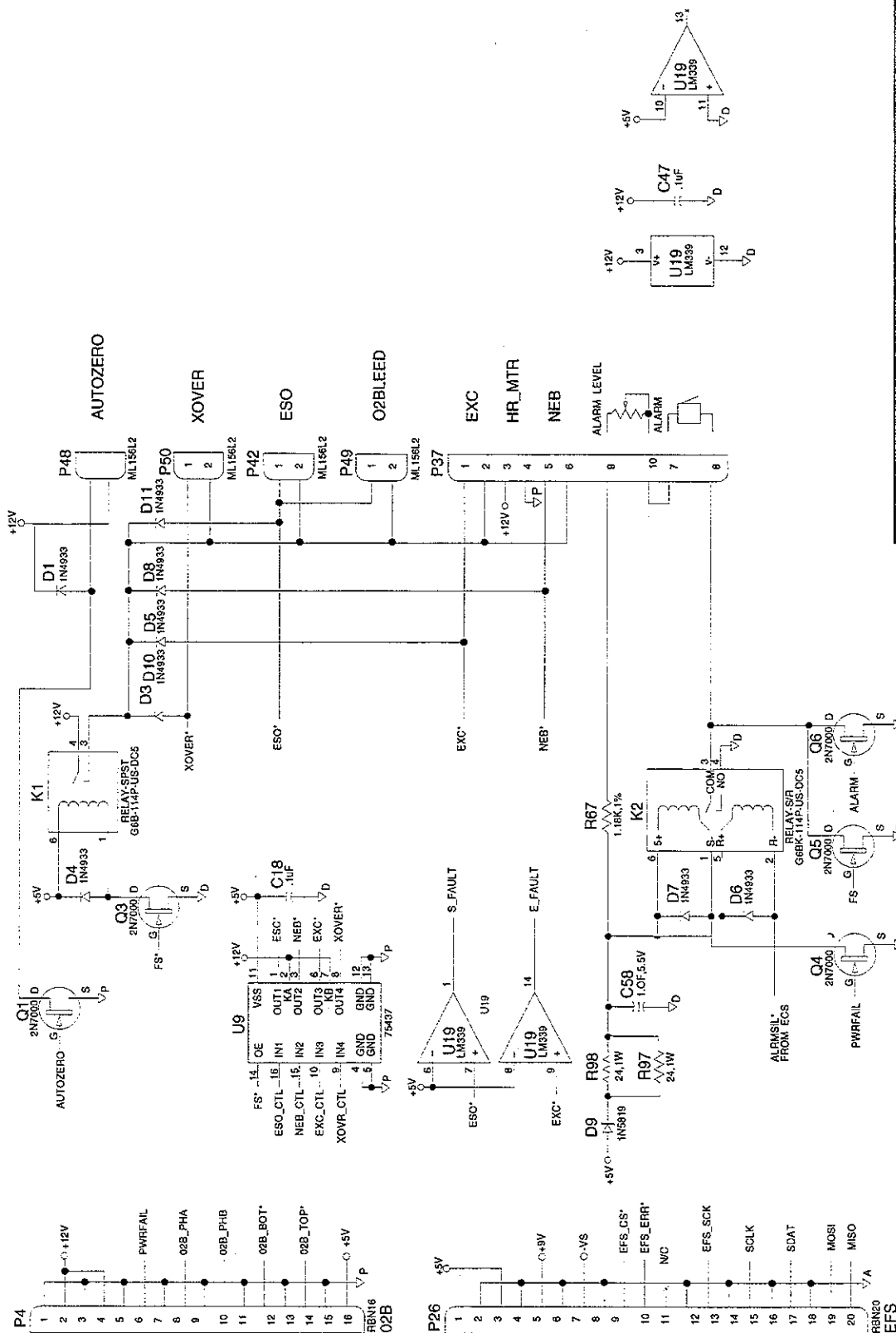

SCHEMATIC DIAGRAM,
ELECTRO-PNEUMATIC
INTERFACE

54805-01843

REV. K SHEET 2 OF 4

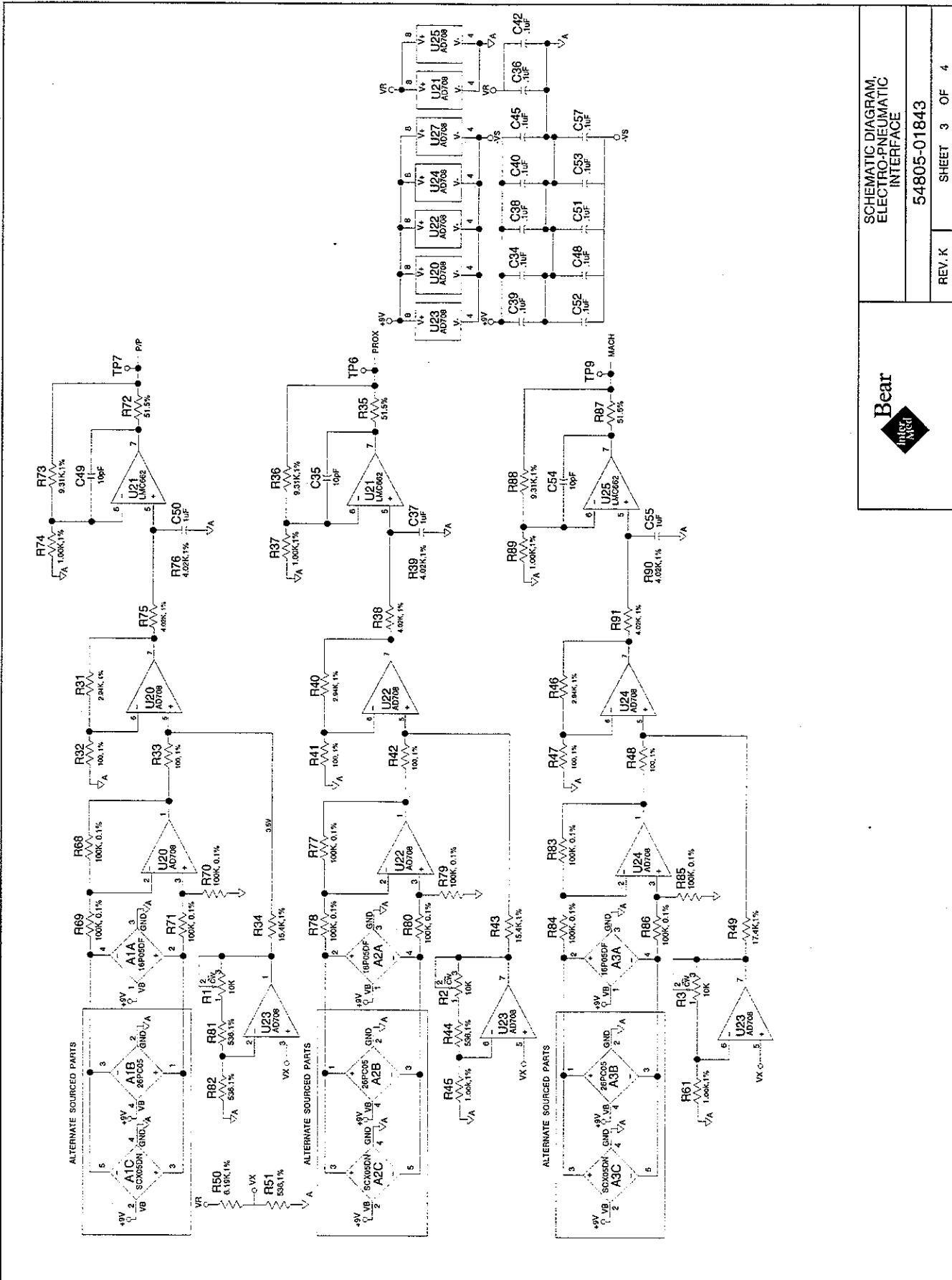

SCHEMATIC DIAGRAM,
ELECTRO-PNEUMATIC
INTERFACE

54805-01843

REV. K

SHEET 3 OF 4

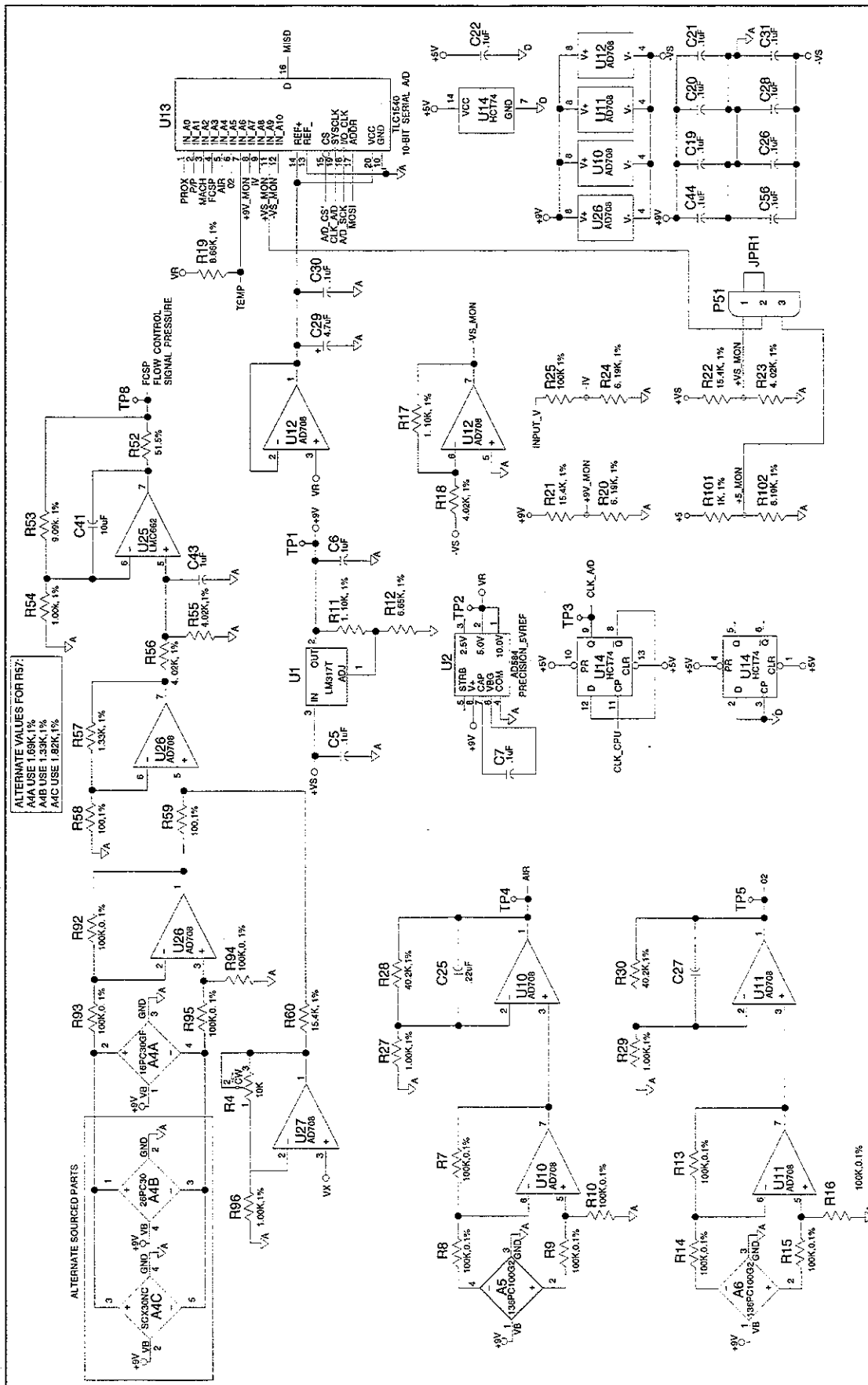

Bear
 Integ
 Neft

SCHEMATIC DIAGRAM,
 ELECTRO-PNEUMATIC INTERFACE

54805-01843

REV. K SHEET 4 OF 4

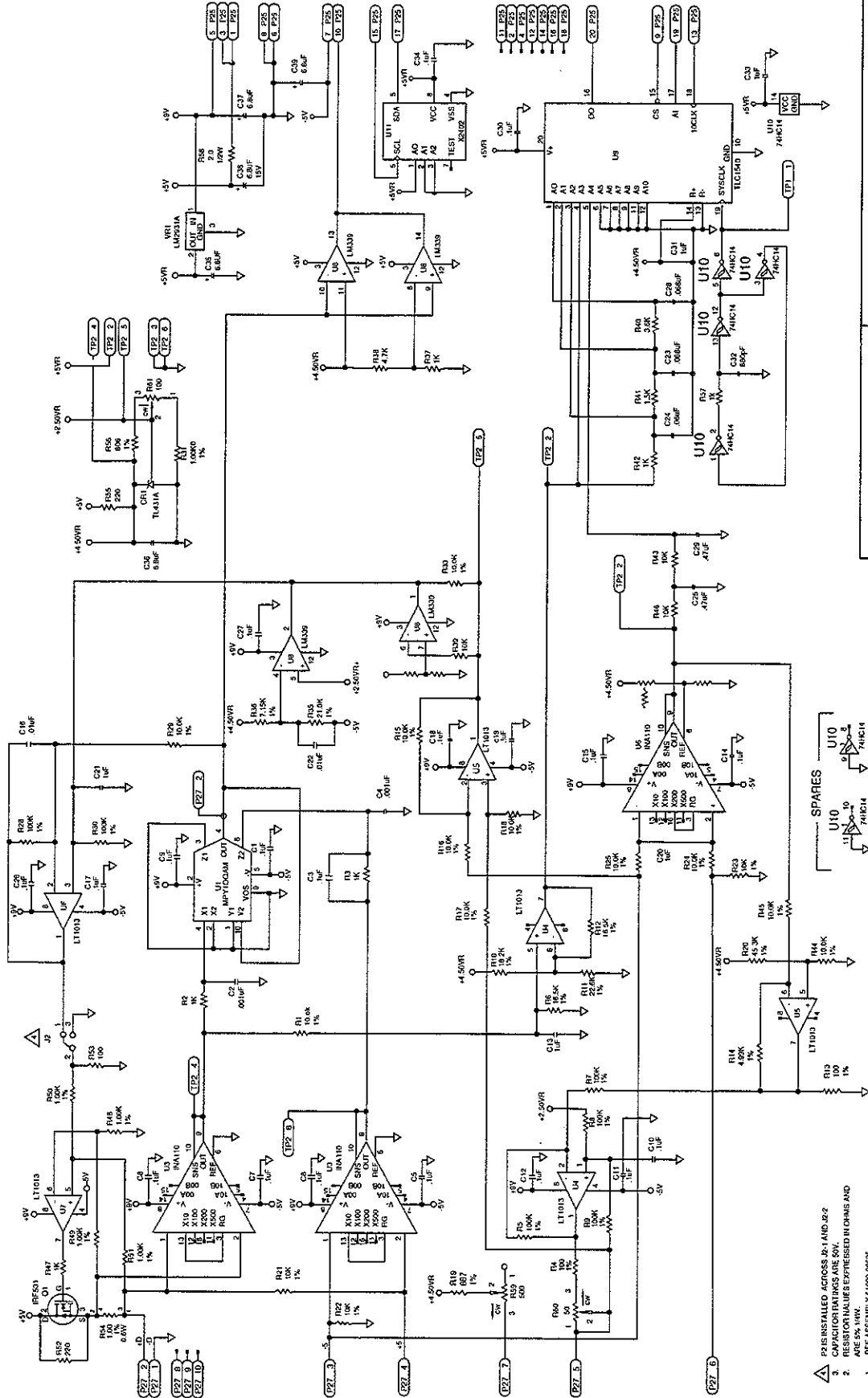

▲ PARTS LISTED ACROSS 26-1 AND J2
 1. RESISTOR VALUES EXPRESSED IN OHMS AND
 ARE 5% 1WV.
 2. REF ASSEMBLY 51000-06025.

Bear
 INK
 JET

**SCHEMATIC DIAGRAM
 EXTERNAL FLOW
 SENSOR**
 54805-01853
 REV. E SHEET 1 OF 1

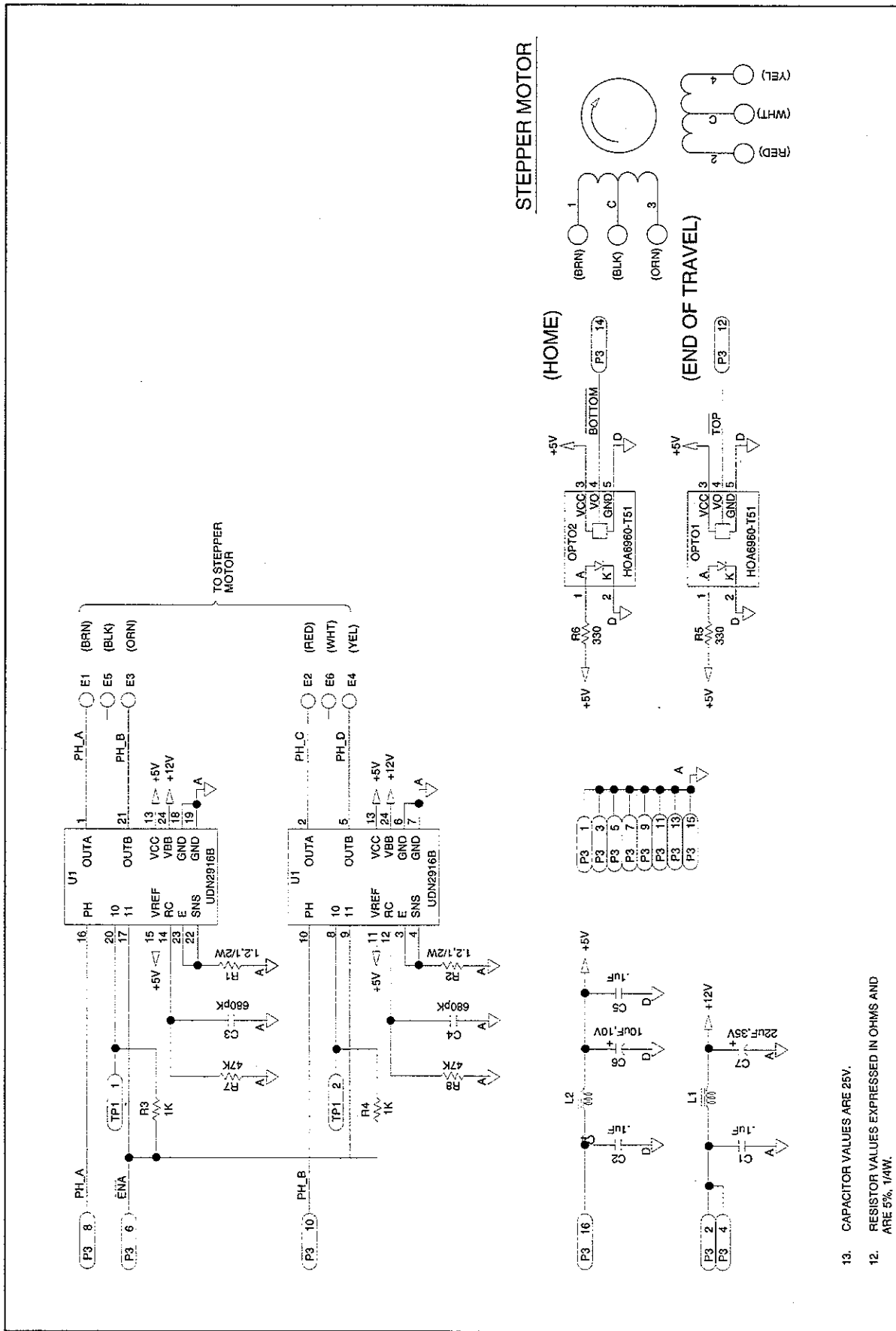

STEPPER MOTOR

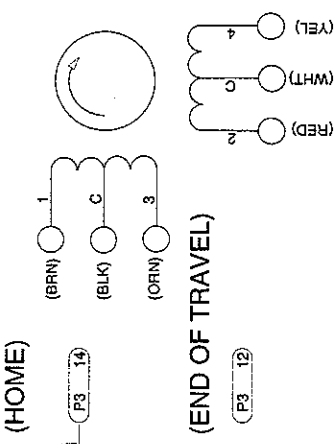

(HOME)

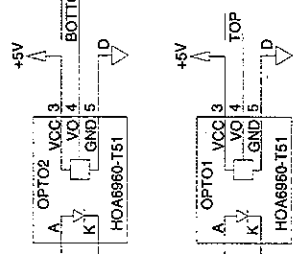

(END OF TRAVEL)

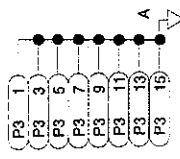
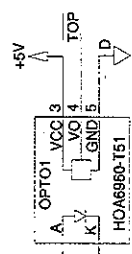

- 13. CAPACITOR VALUES ARE 25V.
- 12. RESISTOR VALUES EXPRESSED IN OHMS AND ARE 5%, 1/4W.
- 11. REF ASSEMBLY 51000-08688

SCHEMATIC DIAGRAM,
OXYGEN BLENDER
PCB

54805-01840

REV. B	SHEET 1 OF 1
--------	--------------

()

()

()

Section 7

BEAR® 1000 Ventilator

Troubleshooting

Error Codes E1 - E30.....	1
Error Codes E32 - E39.....	2
Diagnostic Tests d01 - d03	3
Diagnostic Tests d04 d07	4
Manual Control Mode.....	5

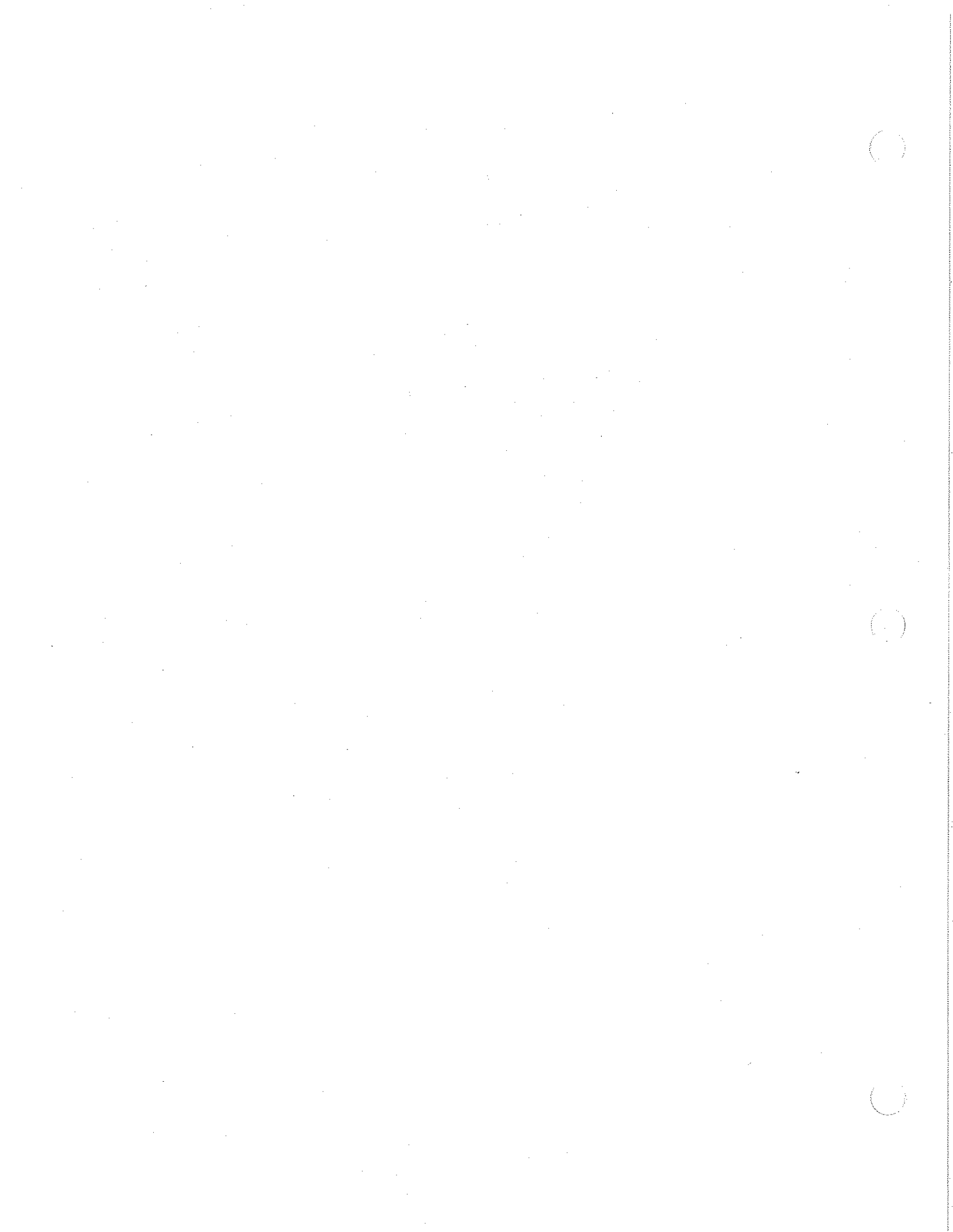

INTRODUCTION

The Information in this section is intended for use by a Bear Medical Systems, Inc., factory trained service technician or bio-medical engineer.

CAUTION

Thoroughly review the Instruction Manual and Section 3 of this maintenance manual before proceeding with any repair.

This section is NOT intended to replace the skills and knowledge of a trained field engineer, but should only serve to expedite the repair of the ventilator.

This section is to assist in isolating a malfunction from the Error Codes generated by the Bear® 1000.

However in most cases, it is not practical or possible to absolutely determine which assembly may be causing a malfunction in field situations. In these instances, the only reasonable method of repair is the substitution of known good assemblies.

The ventilator is able to store the last 16 Error Codes (numbered 1 thru 16) with the highest number representing the most recent occurrence of the error.

This Error Code history may be viewed by entering the Operator Diagnostic mode. The Peak Flow display will contain the error record number and the Oxygen % display will contain the Error Code itself. Rotating the Control Set knob will allow a review of the Error Codes that have been stored.

CAUTION

The error code history may be selectively or completely erased if desired. Prior to doing this, it is strongly recommended that the codes be recorded in the order that they are stored to provide data in the event that there may be some repeat occurrence.

To erase an Error Code, enter the Service Diagnostics mode. Select the Error Number function and using the Control Set knob, display the Error Number to erase. Press the nebulizer key and the Error Number and its corresponding Error Code will be erased from memory. Repeat as required.

Error codes E1 – E9

These codes indicate malfunctions with the Control PCB.

1. Check electrical connections for mechanical integrity and proper orientation.
2. Check for complete seating of socketed components.
3. Substitute the Control PCB with a known functional assembly.

Error codes E10 – E15

These codes indicate malfunctions with the EPI PCB.

1. Check electrical connections for mechanical integrity and proper orientation.
2. Check for complete seating of socketed components.
3. Substitute the EPI PCB with a known functional assembly.

Error codes E20 – E23

These codes indicate malfunctions with the Monitor PCB.

1. Check electrical connections for mechanical integrity and proper orientation.
2. Check for complete seating of socketed components.
3. Substitute the Monitor PCB with a known functional assembly.

Error codes E24 – E30

These codes are not in use at this time.

Error code E31

This error code is related to the solenoid driving circuitry used within the unit.

1. Substitute the EPI PCB with a known functional assembly.

Error code E32

This error code is related to the internal cooling fan.

1. Check to see if the fan is being mechanically jammed by any foreign material.
2. Check the electrical connection between the fan and the EPI PCB.
3. Substitute the fan with a known functional assembly.

Error code E33

This error code is related to the Blending Valve.

1. Check the electrical connection between the Blender and the EPI PCB.
2. Check that there is no foreign substance in the optical detector.
3. Run Operator Diagnostic test d03 to determine if the blender is mechanically jammed.
4. If the error is repeatable, replace the Blender with a functional unit.

Error code E34

This error code is related to the External Flow Sensing System.

1. Check the flow sensor head to insure that both hot wires are intact and not coated with any foreign material.
2. Check the Flow Cable for any damage and secure connections.
3. Check the bulkhead fitting on the ventilator for any signs of damage.
4. Replace the flow head and flow cable individually.
5. Check the electrical connections on the External Flow PCB.
6. If the error is repeatable, replace the External Flow PCB with a known functional unit.

Error code E35

This error code is related to the External Flow PCB.

1. Substitute the External Flow PCB with a known functional assembly.

Error code E36

This error code is related to the Flow Control Valve.

1. Check the electrical connection between the Flow Control Valve and the EPI PCB.
2. Run Operator Diagnostic test d02 to determine if the Flow Control Valve is mechanically jammed.
3. If the error is repeatable, replace the Flow Control Valve with a functional unit.

Error code E37

This error code is related to the Flow Control Valve Electronics.

1. Replace the Flow Control Valve with a functional unit.

Error code E38

This error code is related to the electronics of the EPI PCB.

1. Replace the EPI PCB with a functional unit.

Error code E39

This error code is related to the Power Supply.

1. With the ventilator open and referring to figure 7-1, locate the solder side of the Power Supply Hold Up PCB and the terminal leads of capacitor C2.
2. Check the voltage across these leads. It should be nominally +28 Vdc. If this is not correct, the unit may not be correctly configured for the wall supply voltage or the transformer may be defective.
3. Referring to figure 7-2 and table 7-1, verify the outputs of the power supply. If not within specification, the Power Supply PCB may require replacement.

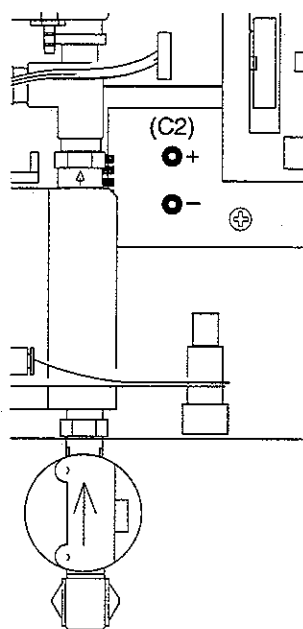

Figure 7-1

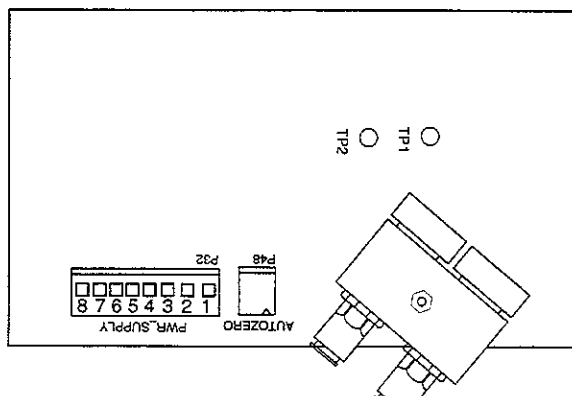

Figure 7-2

P32-1 (GND) – P32-2 (-5 Vdc)	±5%
P32-3 (GND) – P32-4 (+12 Vdc)	±5%
P32-5 (GND) – P32-6 (+5 Vdc)	±5%
P32-8 (GND) – P32-7 (+12 Vdc)	±10%
P32-3 (GND) – TP1 (+9 Vdc)	±5%
P32-3 (GND) – TP2 (+5 Vdc)	Precision Reference

Table 7-1

OPERATOR DIAGNOSTICS CODES

Diagnostic Test d01

This is a test of internal electronic functions. A failure of this test would result from a malfunction of the Control PCB and would also generate error codes E1 – E9 in normal operation.

1. Check electrical connections on the Control PCB for mechanical integrity and proper orientation.
2. Check for complete seating of socketed components.
3. Substitute the Control PCB with a known functional assembly.

Diagnostic Test d02

This is a test of the Flow Control Valve requiring it to reach a fully open and fully closed state within a specific number of step commands.

NOTE

This error may occur if the diagnostics are run with a Graphics Display connected and operating. Repeat test with Graphics Display turned off.

1. Check the electrical connection to the EPI PCB for mechanical integrity and proper orientation.
2. Substitute the Flow Control Valve with a known functional assembly.

Diagnostic Test d03

This is a test of the Blender Control Valve requiring it to reach a fully open and fully closed state within a specific number of step commands.

NOTE

This error may be generated by performing diagnostics with the Blender exposed to high levels of light. Repeat test with upper console closed.

1. Check the electrical connection to the EPI PCB for mechanical integrity and proper orientation.

2. Substitute the Blender Control Valve with a known functional assembly.

Diagnostic Test d04

This is a test for pneumatic leaks. A specific amount of gas is delivered and the pressure in the patient circuit is recorded. After five seconds the pressure is checked again and must be within ± 10 cmH₂O of the first reading.

1. Check leaks in the patient circuit.
2. Check for complete seating of the Exhalation Manifold and integrity of the Exhalation Balloon.
3. Check the patient outlet fitting for tightness and the check valve within it.
4. Check for an internal leak along all of the connections on the Proximal Airway pressure line.
5. Check the calibration and stability of the Proximal Pressure Transducer.

Diagnostic Test d05

This is a test of both Flow Delivery and External Flow Sensing.

The internal Accumulator is allowed to charge and its pressure is checked. At this time External Flow is checked to be at normal levels.

The ventilator will then deliver 60 LPM for two seconds and the Accumulator pressure and External Flow is again checked.

This process is repeated for a flow of 150 LPM.

1. Check for internal leaks or occlusions particularly in high pressure lines.
2. Check that the external gas supply is adequate for the ventilator.
3. Repeat test d02 to check for a possible Flow Control Valve Failure.
4. Check the calibration of the Flow Control Valve Transducer.

5. Check the External Flow Sensor as described for error code E34.

Diagnostic Test d06

This is a test of the Sub-Ambient/Over-pressure Relief Valve (SOPR). The valve is opened and its resistance to 60 LPM of flow is measured.

1. Check the calibration of the Proximal Pressure Transducer.
2. Substitute a known functional SOPR Valve.
3. Check for leakage from the Shut Off Solenoid (This would inflate the SOPR balloon).
4. Check the output of the Flow Control Valve (flow too high), Diagnostic Test d02.

Diagnostic Test d07

This is a test of Pressure Delivery and Pressure Sensing.

First the outputs of the Proximal, Delta, and Machine pressure transducers are checked with minimum pressure.

Second, the Proximal and Machine pressure transducers are checked with 60 cmH₂O applied and then with 120 cmH₂O applied.

NOTE

This error may occur if PEEP is turned on. Make sure that PEEP is completely off and repeat test.

1. Check the calibrations of the Proximal, Delta, and Machine pressure transducers.
2. Check for both external and internal leaks.
3. Check the Exhalation Valve and SOPR Valve for proper assembly and operation.
4. Check the Flow Control Valve for proper operation (Diagnostic Test d02).
5. Substitute a known functional EPI PCB.

MANUAL CONTROL MODE

The Manual Control mode of the Service Diagnostics may be of assistance to the technician. Individual stepper motors, solenoids, and the audible alarms can be activated from the Control Panel.

After entering the Service Diagnostics Mode, refer to figure 7-2 and press the Manual Control button. The functions shown on the Control Panel will then be available.

To actuate the Flow Control Valve (FCV), select it and use the Control Set knob to increment the step count displayed. The same actions will control the Blender Control Valve (BCV).

NOTE

The number of steps indicated will not directly correspond to a particular flow or oxygen setting. Each valve is individually calibrated and correction curves stored on the valve electronics.

Solenoids are activated in a toggle fashion. A "0" in the display window indicates power off and "1" indicates power is applied.

The Audible Alarm toggles between a sounding or non-sounding mode.

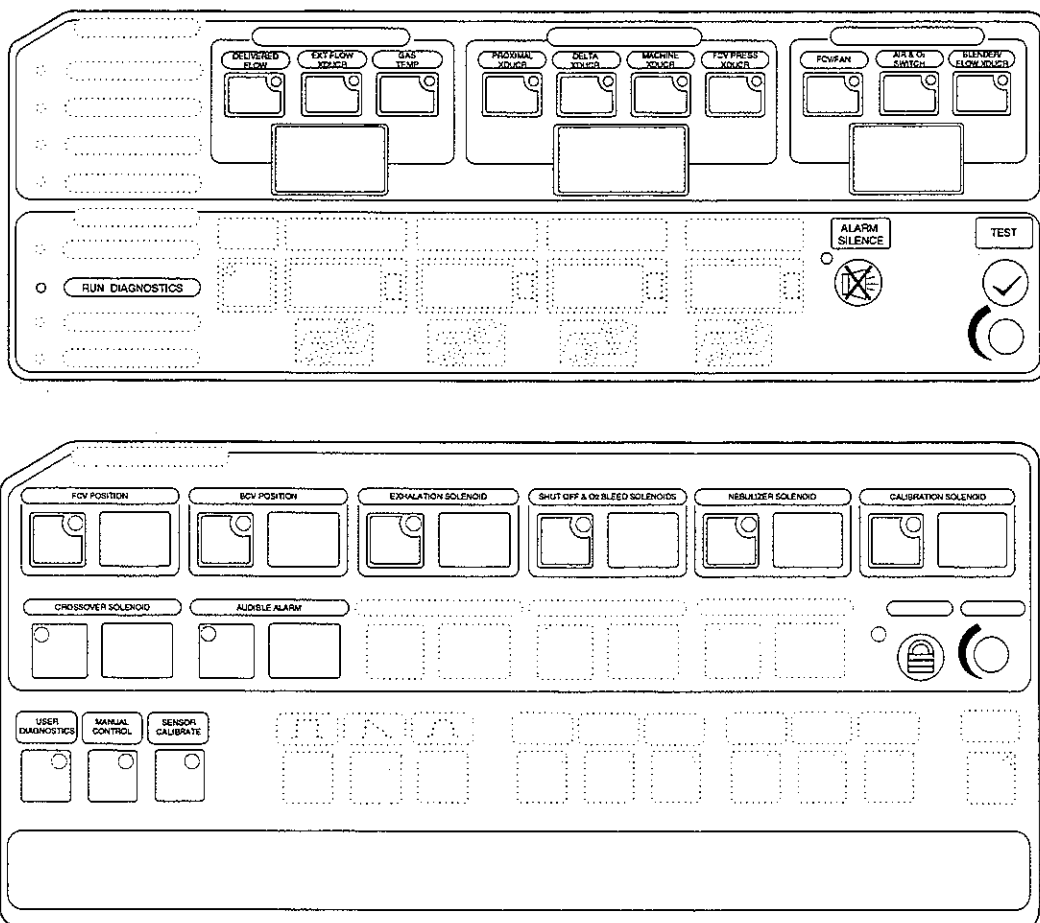

Figure 7-2
Manual Control Mode

Section 8

BEAR[®] 1000 Ventilator

Removal and Replacement

EPI PCB	1
Air & O2 Blender	2
Air & O2 Inlet Manifold	2
Power Supply Module	3
Power Supply Hold Up Capacitor Assy	3
Accumulator Assy	4
External Flow Sensor PCB.....	4
Fan Assembly	4
Shut Off Solenoid	4
Alarm Loudness Assembly.....	5
AC Outlet for Graphics Display	5
Power Entry Module	5
Main Power Receptacle	6
Fuse Holders.....	6
AC Line EMI/RFI Filter.....	6
Power Switch.....	6
Transformer Assembly	6
Flow Control Valve Assembly	7
Buzzer Assembly	7
Sub-Ambient/Overpressure Relief Assy	7
Nebulizer Solenoid Valve.....	7
Nebulizer Regulator Assembly	7
Exhalation Valve Solenoid Assembly	7
Exhalation Valve Regulator.....	9
Exhalation Valve Bulkhead Assembly	9
External Flow System Internal Cable Assy	9
Control PCB	9
Monitor PCB.....	9
Proximal Gauge	9
Control Panel.....	10
Monitor Panel	10
Needle (PEEP) Valve	10
Optical Encoder (Control Set).....	10
Optical Encoder (Monitor Set)	11

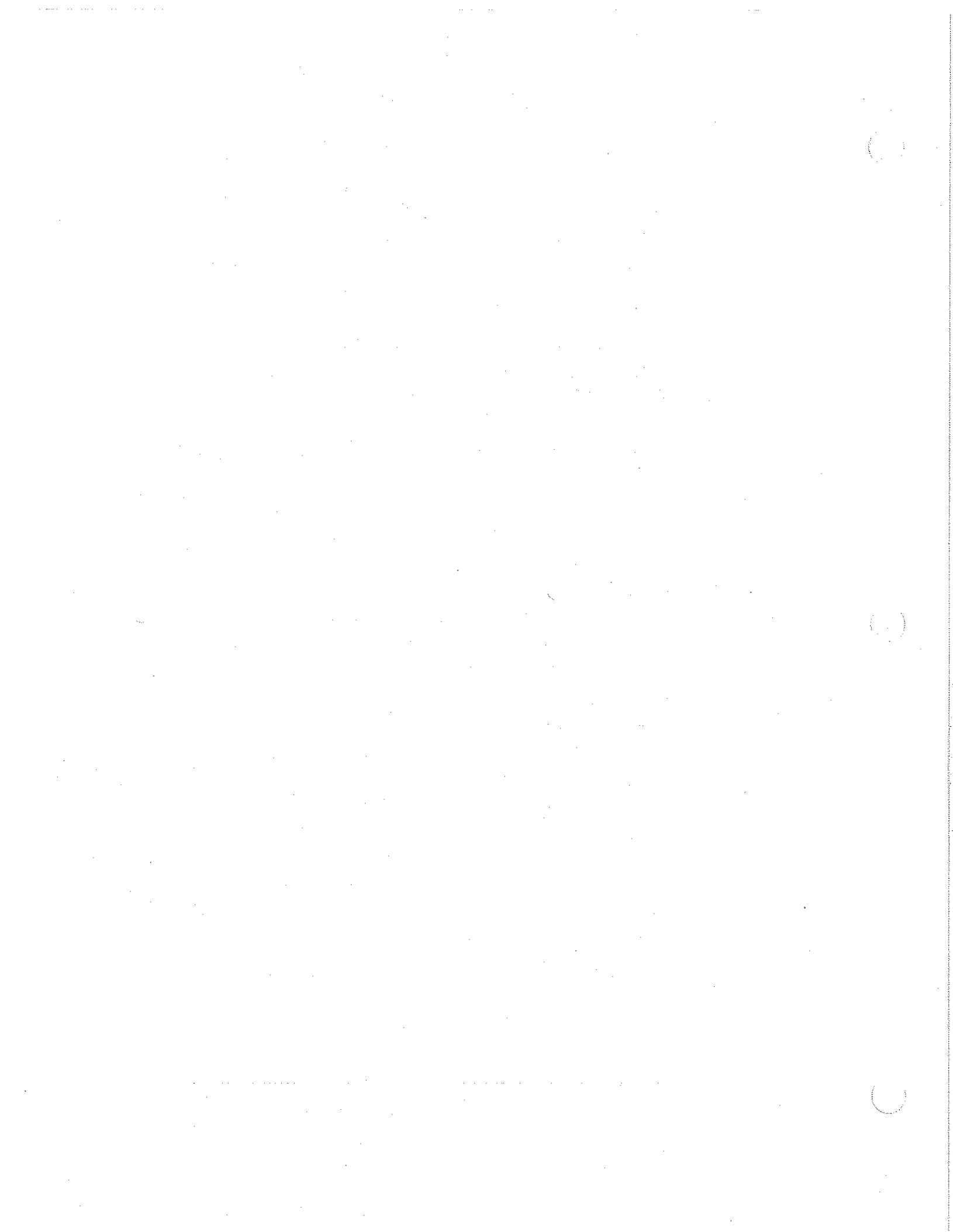

WARNING

Disconnect all electrical power, air, and oxygen sources before attempting any disassembly. Failure to do so could result in injury to the service technician or damage to equipment.

WARNING

After replacement of any assembly(ies), always repeat the Operational Verification Procedure (section 3), then allow a "burn-in" period and repeat the Operational Verification Procedure.

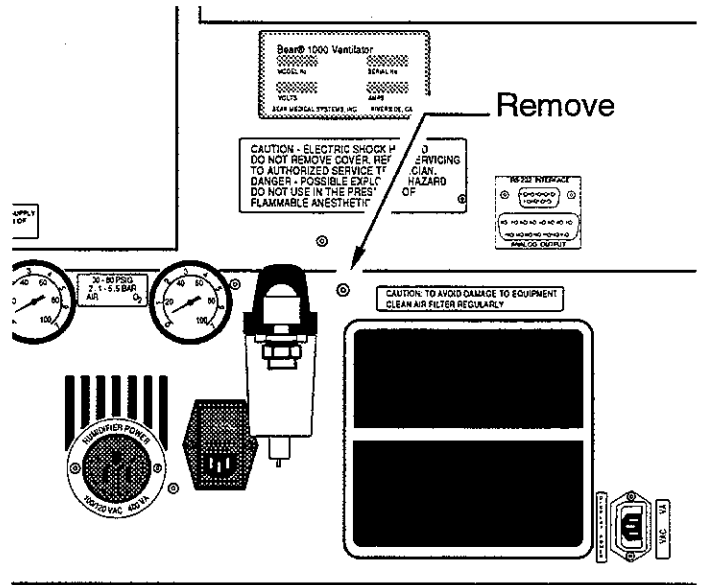

**Figure 8-1
Console Interior Access**

EPI PCB - 51000-08670 or 51000-21XXX

Interior Access

1. If connected, remove cables leading to RS-232 and Analog outputs ports of the ventilator.
2. Remove the screw indicated in Figure 8-1.
3. Tilt the console forward to its rest position.

1. Label or mark electrical cables prior to removal to insure proper assembly noting both designation and location of pin 1.

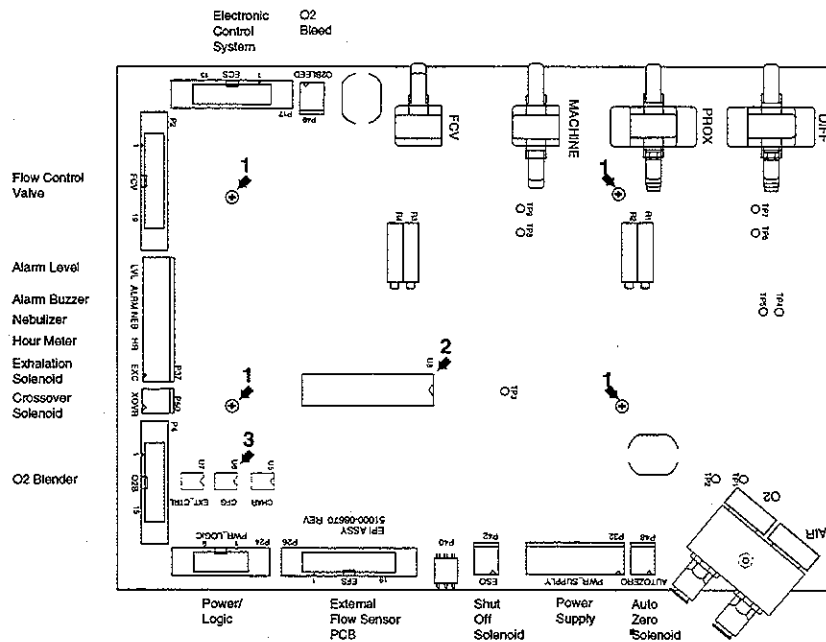

**Figure 8-2
EPI PCB**

REMOVAL AND REPLACEMENT

- After marking or labeling, remove the silicone and PVC tubing from the transducers
- After marking or labeling, remove the high pressure lines from the Air and O₂ pressure transducers by pushing in the collar while pulling on the tubing.
- Remove the four mounting screws from the EPI PCB (Figure 8-2, Ref. 1).

NOTE

If the CFG EPROM, U6, is soldered in place, contact Bear Medical Systems, Inc. for further instructions.

- Remove the MPU, U8 (Figure 8-2, Ref. 2), and the CFG EPROM, U6 (Figure 8-2, Ref. 3), and place them in the replacement EPI PCB, being sure of proper orientation.
- To install the replacement PCB, reverse the removal instructions.
- Perform the transducer calibrations as described in Section 5, and the OVP as described in Section 3.

Air & O₂ Blender - 51000-08562 or 51000-21XXX

- Remove the ribbon cable (Figure 8-3, Ref. 1) at its connection on the EPI PCB.

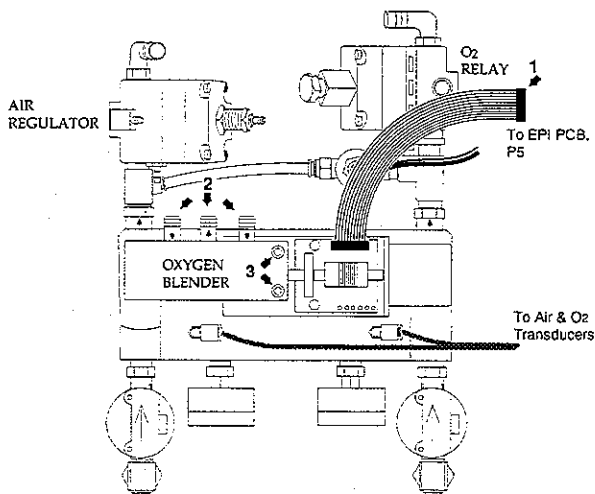

Figure 8-3
Air & O₂ Blender

WARNING

Do not interchange a socketed (U6) EPIPCB for non-socketed PCB. It is mandatory to install the same CFG EPROM (U6) into the new PCB.

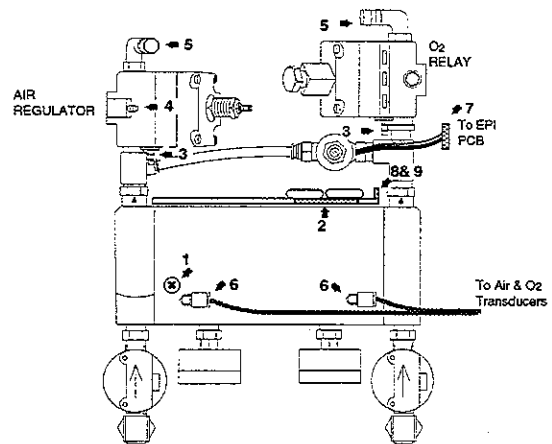

Figure 8-4
Inlet Manifold

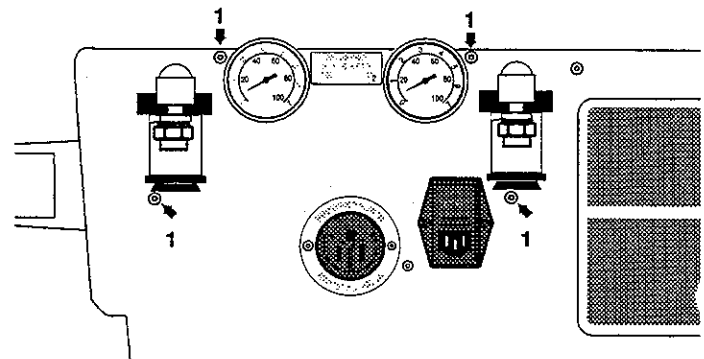

Figure 8-5
Inlet Manifold Mounting Screws

- Mark or tag the PVC hoses (Figure 8-3, Ref. 2) coming from the Blender and remove.
- Remove the two mounting screws (Figure 8-3, Ref. 3) and remove the Blender from the ventilator.
- To install the replacement Blender, reverse the removal instructions replacing any cable ties or tube clamps removed during the process.
- Perform the OVP as described in Section 3 to verify the proper operation of the Blender.

Air & O₂ Inlet Manifold - 51000-08622 or 51000-21XXX

- Perform the procedure to remove the Air & O₂ Blender.
- Remove the pneumatic and electrical connections indicated in Figure 8-4 Ref. 1 - 9, marking as required to facilitate re-assembly.
- Remove the bowls of the water traps on the rear of the unit.

5. Remove the four screws (Figure 8-5, Ref. 1) and lift the manifold from the ventilator.
6. Remove the two screws and lift Power supply from the manifold.
7. To install the replacement manifold, reverse the removal instructions replacing any cable ties or tube clamps removed during the process.
8. Perform the regulator calibrations as described in Section 5, and the OVP as described in Section 3.

Power Supply Module - 51000-08670 or 51000-21XXX

1. Perform the procedure to remove the Air & O2 Blender.
2. Perform the removal of the Air & O2 Inlet Manifold.
3. Remove the two screws that secure the Power supply to the Inlet Manifold Assembly.
4. To install the replacement PCB, reverse the removal instructions.

Power Supply Hold Up Capacitor Assy - 51000-08671 or 51000-21XXX

1. Perform the procedures to remove the following assemblies:
 EPI PCB
 Air & O2 Blender.
 Air & O2 Inlet Manifold.
2. After marking for correct orientation, remove connector J45 from the PCB (Figure 8-6, Ref. 4).
3. Remove the two phillips screws securing the PCB to the ventilator chassis (Figure 8-6, Ref. 5).
4. To install the replacement PCB, reverse the removal instructions.

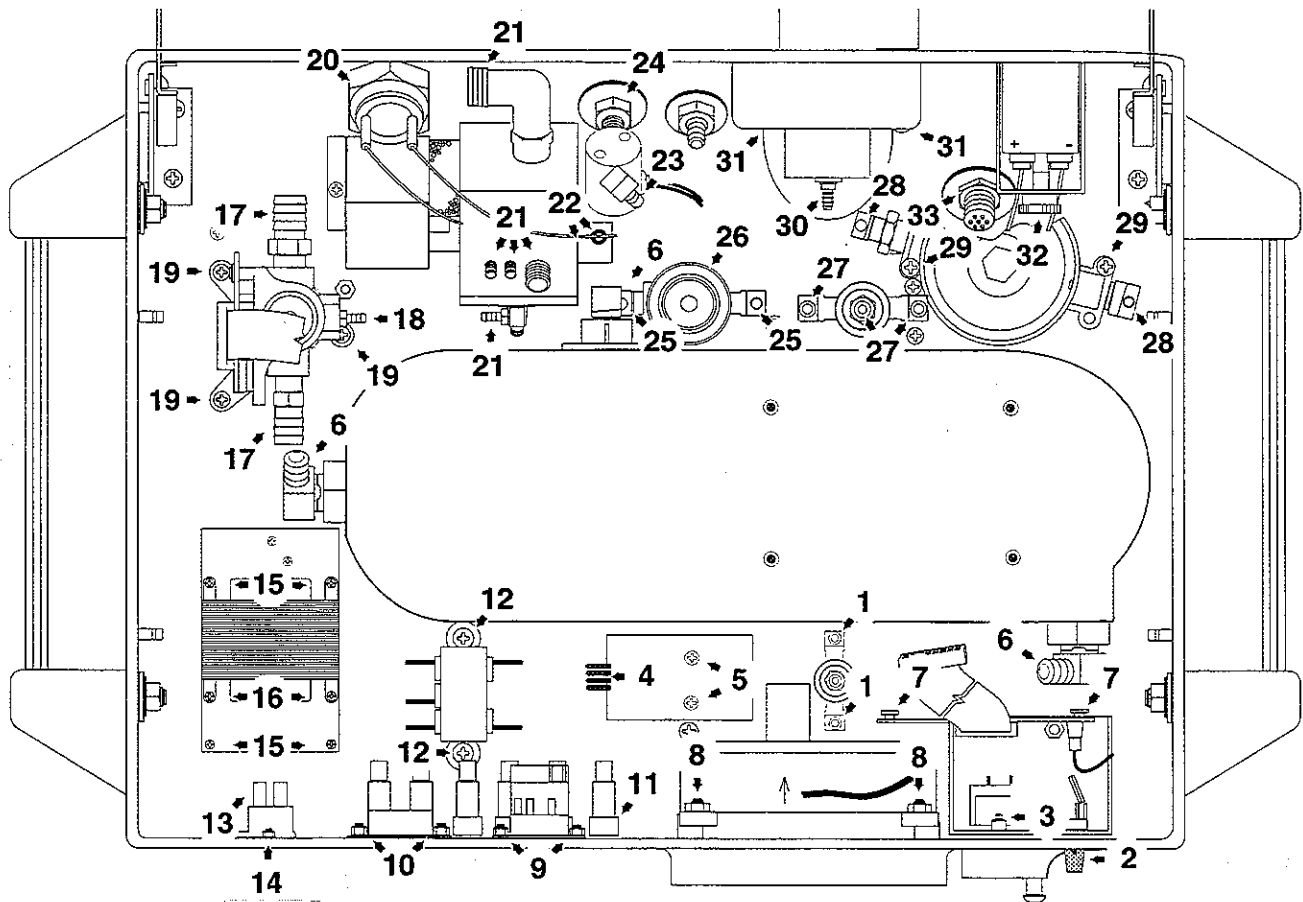

Figure 8-6
Lower Console

Accumulator Assembly - 51000-08623

NOTE

If the ventilator is mounted to a cart or a compressor module, it must be removed prior to removing the Accumulator Assembly.

1. Perform the procedures to remove the following assemblies:
 - EPI PCB
 - Air & O2 Blender.
 - Air & O2 Inlet Manifold.
2. Remove the three pneumatic connections to the Accumulator Assembly (Figure 8-6, Ref. 6).
3. After closing the ventilator, tilt it on its side or back and remove the large phillips screw in the center position on the bottom.
4. Lift the Accumulator Assembly free of the ventilator.

External Flow Sensor PCB - 51000-08625 or 51000-21XXX

NOTE

While it is possible to remove this assembly without involving other assemblies, it will be difficult due to the position of the mounting screws within the chassis. A long, magnetized, phillips screwdriver or holding screwdriver would be required to start and tighten the screws for assembly.

1. Perform the procedures to remove the following assemblies:
 - EPI PCB
 - Air & O2 Blender.
 - Air & O2 Inlet Manifold.
 - Accumulator Assembly
2. After marking for correct orientation, remove connector J26 from the EPI PCB.
3. After marking for correct orientation, remove connector J27 from the External Flow Sensor PCB.
4. Remove the mounting brackets for installation on the replacement PCB.

Fan Assembly - 51000-08609

NOTE

There have been three configurations in the way that the fan is mounted. It will require visual inspection to determine the appropriate hardware required for replacement.

The key items are whether the fan is secured by screws and nuts and whether there is a metal shroud between the fan and the ventilator chassis.

If required order:

4 ea. 6-32 x 3/4" screw	53002-16212
Shroud	51000-08871

1. Remove the two foam ambient air intake filters.
2. Remove the 4 fan mounting screws (Figure 8-6, Ref. 8).

WARNING

If the fan is of the type with screws and nuts, be certain that none of the nuts are lost within the ventilator.

2. Remove connector J40 from the EPI PCB and pull the fan free of the ventilator.
3. Install the replacement fan by reversing the removal instructions noting that air flow (indicated by an arrow on the fan body) is into the ventilator.

Shut Off Solenoid- 51000-08720

1. Perform the procedures to remove the following assemblies:
 - EPI PCB
 - Fan Assembly
2. Remove the two phillips screws (Figure 8-6, Ref. 1) securing the mounting bracket to the chassis of the ventilator.

- Remove the two screws attaching the mounting bracket to the solenoid.

Alarm Loudness Assembly - 51000-08717

- Perform the procedures to remove the following assemblies:
 - EPI PCB
 - External Flow sensor PCB
- Remove the Alarm Loudness knob (Figure 8-6, Ref. 2) using an allen wrench.
- Remove the mounting nut at the rear of the ventilator and remove the control from the console.

AC Outlet for Humidifier - 56090-20385

- Perform the procedures to remove the following assemblies:
 - Air & O2 Blender.
 - Air & O2 Inlet Manifold.
- After marking or labeling the three wires going to the back of the outlet, remove the three retaining screws.

WARNING

Be certain that neither of the mounting nuts are lost within the ventilator.

- Remove the two outlet mounting screws (Figure 8-6, Ref. 10) and remove the outlet from the inside of the ventilator.

AC Outlet for Graphics Display - 56060-20559

- Perform the procedures to remove the following assemblies:
 - EPI PCB
 - External Flow sensor PCB
- Mark or label the three faston connectors to the outlet for proper assembly and remove.
- Remove the two mounting screws (Figure 8-6, Ref. 3) using an allen wrench.

Power Entry Module (PEM) - 56090-20558

NOTE

The voltage selector drum is not included as part of this assembly. If required, order separately under part number 56001-00239.

NOTE

The fuse receptacles in the Power Entry Module are not used and fuses will probably be absent. It is not necessary to install anything in their locations.

WARNING

Be certain that neither of the mounting nuts are lost within the ventilator.

- Perform the procedures to remove the following assemblies:
 - Air & O2 Blender.
 - Air & O2 Inlet Manifold.
- Mark or label the 6 faston connectors as to position and remove.
- Mark or label the two wires going to the power switch and remove at the power switch end.
- Using an allen wrench, remove the power cord retaining bracket.
- Using an allen wrench, remove the mounting screws and nuts from the Power Entry Module (Figure 8-6, Ref. 9).
- After removing the heat shrink tubing, unsolder the two lower wires from the Power Entry Module, noting locations.

WARNING

Be certain that neither of the mounting nuts are lost within the ventilator.

- Solder the wires to the replacement module, covering the joints with heat shrink tubing.

REMOVAL AND REPLACEMENT

8. Transfer the voltage selector drum from the original module to the replacement and reinstall.

Main Power Receptacle - 56090-20385

1. Perform the procedures to remove the following assemblies:
 - Air & O2 Blender.
 - Air & O2 Inlet Manifold.
2. Noting or marking as to orientation, remove the two wires going to the fuses at the fuse end and the ground wire going to the main ground stud.
3. Using an allen wrench, remove the mounting screws and nuts from the receptacle (Figure 8-6, Ref. 10).
4. Transfer the three wires from the old receptacle to the new one.

Fuse Holder (6 ea) - 56001-00245

NOTE

Fuses are not included as part of this assembly. If required, follow the labeling on the rear of the unit to obtain replacement fuses of the proper rating.

NOTE

Removal instructions for each of the 6 fuse holders is the same except that either the Main Power receptacle or the Power Entry Module may have to be removed to get access.

1. Perform the procedures to remove the following assemblies:
 - Air & O2 Blender.
 - Air & O2 Inlet Manifold.
2. If required, remove either:
 - Power Entry Module
 - Main Power Receptacle
3. After noting or marking wires as to location, remove them from the Fuse Holder body.
4. Using an wrench, loosen and remove the retaining nut and remove the holder through the back of the unit (Figure 8-6, Ref. 11).

AC Line EMI/RFI Filter - 56001-00175

1. Perform the procedures to remove the following assemblies:
 - Air & O2 Blender.
 - Air & O2 Inlet Manifold.
2. After noting or marking wires as to location, remove the 5 faston connectors to the filter.
3. After noting orientation, remove the filter by removing the two phillips screws (Figure 8-6, Ref. 12).

Power Switch - 56080-10078

1. Perform the procedures to remove the following assemblies:
 - Air & O2 Blender.
 - Air & O2 Inlet Manifold.
2. Noting or marking as to connection points, remove the four connectors from the rear of the switch (Figure 8-6, Ref. 13).
3. Using an allen wrench, remove the two screws and nuts from the switch (Figure 8-6, Ref. 14).
4. Pull the switch out through the rear of the ventilator.

Transformer Assembly - 51000-08716

1. Perform the procedures to remove the following assemblies:
 - Air & O2 Blender.
 - Air & O2 Inlet Manifold.
2. Noting or marking as to connection points, remove the four wires going to the EMI/RFI filter.
3. Remove the one wire going to the Power Entry Module.
4. Unplug the connector going to the Power Supply Assembly.
5. Remove the four screws (Figure 8-6, Ref. 15) from the transformer mounting plate.
6. Remove the two screws and nuts securing the transformer to the mounting plate (Figure 8-6, Ref. 16).

NOTE

The mounting plate is not included as part of this assembly. If required, order separately.

Flow Control Valve (FCV) - 51000-08520 or 51000-21XXX

1. Perform the procedures to remove the following assemblies:
 - Air & O2 Blender.
 - Air & O2 Inlet Manifold.
2. Remove the ribbon cable going to the EPI PCB connector P2.
3. Remove the hoses (Figure 8-6, Ref. 17 & 18) from the FCV.
4. Remove the three screws (Figure 8-6, Ref. 19) from the base of the FCV.
5. Remove the FCV from the ventilator.

Buzzer Assembly - 51000-08608

1. Unplug the Alarm Buzzer connector from the EPI PCB (Figure 8-2).
2. Unscrew the large holding nut from the inside of the ventilator (Figure 8-6, Ref. 20).
3. Remove the Buzzer from the front of the ventilator.

Sub-Ambient/Overpressure Relief Valve Assembly (SOPR) - 51000-08540 or 51000-21XXX

1. After labeling or marking, remove the pneumatic connections from the valve (Figure 8-6, Ref. 21).
2. Remove the screw securing the mounting bracket to the chassis and the screw securing the mounting bracket to the SOPR valve (Figure 8-6, Ref. 22).
3. Unscrew the outlet fitting from the front of the ventilator and remove the valve from the ventilator.

NOTE

When installing the SOPR valve ensure that the grounding connection is attached to the screw securing the mounting bracket to the valve body.

Nebulizer Solenoid Valve - 51000-08722**NOTE**

A 1/2 " crowfoot style wrench is required for the proper removal and installation of this solenoid.

1. Remove the Nebulizer Electrical connector from the EPI PCB (Figure 2).
2. Remove the screw from the top of the solenoid that secures the two grounding wires.
3. Remove the pneumatic connection from the Nebulizer Solenoid (Figure 8-6, Ref. 23).
4. Using the 1/2 " crowfoot wrench, loosen the chrome nut on the inside of the ventilator that secures the bulkhead fitting to the chassis.
5. From the outside of the ventilator, unscrew the the bulkhead fitting from the Nebulizer solenoid, loosening the inside nut as required.

Nebulizer Regulator Assembly - 51000-08724

1. Perform the procedures to remove the following assemblies:
 - EPI PCB.
2. Remove the two pneumatic connections from the Nebulizer Regulator (Figure 8-6, Ref. 25).
3. Unscrew the retaining collar from the Nebulizer Regulator (Figure 8-6, Ref. 25).
4. Slide the regulator from the bracket and remove from the ventilator.
5. After installation, perform the regulator calibration as described in Section 5 of this manual.

Exhalation Valve Solenoid Assembly - 51000-08721

1. Perform the procedures to remove the following assemblies:
 - EPI PCB
 - Exhalation Valve Regulator
2. Remove the two pneumatic connections from the solenoid (Figure 8-6, Ref. 27).

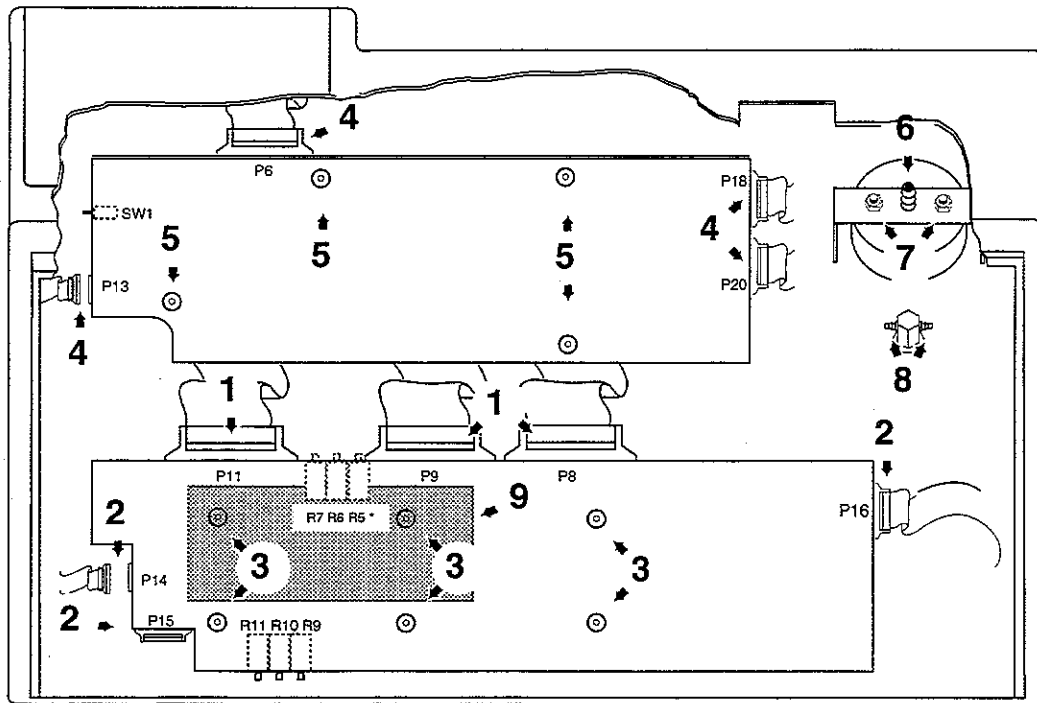

Figure 8-7
Upper Console

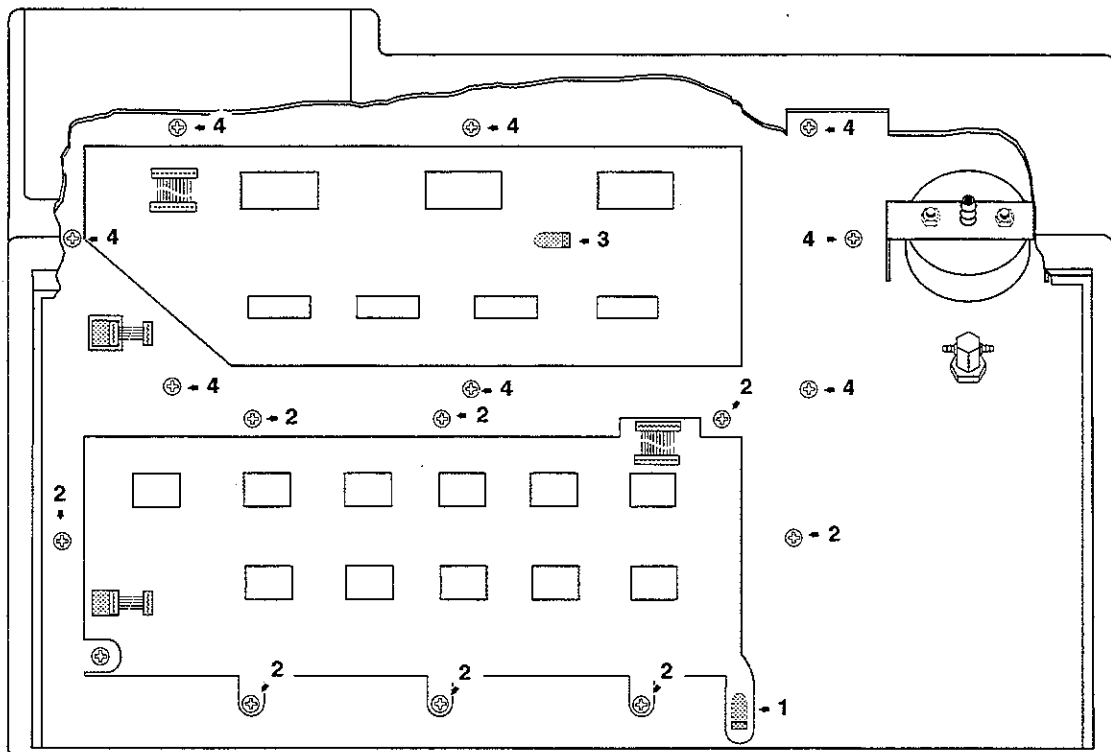

Figure 8-8
Upper Console (PCB's Removed)

3. Remove the two screws securing the mounting bracket to the ventilator chassis and remove the assembly from the ventilator.
4. Remove the two screws securing the solenoid to the mounting bracket.

Exhalation Valve Regulator - 51000-08723

1. Perform the procedures to remove the following assembly:
EPI PCB
2. Remove the two pneumatic connections to the regulator (Figure 8-6, Ref. 28).
3. Remove the two screws securing the regulator to the mounting bracket and remove the regulator from the ventilator.
4. After installation, perform the calibration as described in Section 5 of this manual.

Exhalation Valve Bulkhead Assy. - 51000-08635

1. Perform the procedures to remove the following assembly:
EPI PCB
Accumulator Assy.
2. Remove the pneumatic connection from the assembly (Figure 8-6, Ref. 30).
3. Remove the two screws from the bulkhead assembly (Figure 8-6, Ref. 31).
4. Pull the assembly out through the front of the ventilator.
5. Unscrew the Diaphragm Mounting Base from the bulkhead assembly.

External Flow System Internal Cable Assy. - 51000-08632

1. Perform the procedure to remove the following assembly:
EPI PCB
Exhalation Valve Regulator

2. Remove the mounting nut from the Hour meter (Figure 8-6, Ref. 32) and slide it forward.
3. Unplug the ribbon cable from the External Flow PCB.
4. Unscrew the mounting nut (Figure 8-6, Ref. 33) from the inside of the ventilator and remove the the assembly through the front of the unit.

Control PCB - 51000-08674 or 51000-21XXX

1. Detach the ribbon cables P8, P9, P11 from the Control PCB (Figure 8-7, Ref 1).
2. Detach the ribbon cables P14, P15, P16, from the Control PCB (Figure 8-7, Ref 2).
3. Remove the six screws (Figure 8-7, Ref 3) and insulator (Figure 8-7, Ref. 9).
4. Remove EPROM, U86, and install into replacement PCB taking care as to proper orientation.

Monitor PCB - 51000-08676 or 51000-21XXX

1. Detach the ribbon cables P9, P11, (Figure 8-7, Ref 1) from the Control PCB.
2. Detach the ribbon cables P6, P13, P18, P20 (Figure 8-7, Ref 4).
3. Remove the four screws (Figure 8-7, Ref 5) from the Monitor PCB.
4. Remove MPU, U9, and install into replacement PCB taking care as to proper orientation.

Proximal Gauge - 52000-00964

1. Remove the silicone tubing to the Proximal Pressure Gauge (Figure 8-7, Ref 6).
2. Remove the two nuts (Figure 8-7, Ref 7) from the studs retaining the mounting bracket.
3. Remove the Proximal Gauge through the from of the ventilator.

Control Panel - 51000-08551

NOTE

The inserts that identify the indicators and controls for this panel and not included with this assembly since they are dependent on the configuration of the unit. Contact Bear Medical Systems for the part numbers required.

NOTE

There is a gasket between the Control Panel and the upper Console. It should remain intact when the panel is replaced. If it is damaged, a replacement can be ordered under part number 51000-08657.

1. Perform the procedure to remove the following assembly:
Control PCB
2. Remove the grounding wire (Figure 8-8, Ref. 1) from the Control Panel.
3. Remove the 8 screws from the Control Panel (Figure 8-8, Ref. 1).
4. Remove the Control Panel through the front of the ventilator.

Monitor Panel - 51000-08550

NOTE

The inserts that identify the indicators and controls for this panel and not included with this assembly since they are dependent on the configuration of the unit. Contact Bear Medical Systems for the part numbers required.

NOTE

There is a gasket between the Monitor Panel and the upper Console. It should remain intact when the panel is replaced. If it is damaged, a replacement can be ordered under part number 51000-08656.

1. Perform the procedure to remove the following assembly:
Monitor PCB
2. Remove the grounding wire (Figure 8-8, Ref. 3) from the Monitor Panel.
3. Remove the 8 screws from the Monitor Panel (Figure 8-8, Ref. 4).

4. Remove the Monitor through the front of the ventilator.

Needle (PEEP) Valve - 51000-08927

1. Remove the two pneumatic connections from the Needle Valve (Figure 8-7, Ref 8).
2. Remove the knob from the front of the ventilator with an allen wrench.
3. Remove the mounting nut from the front of the ventilator.
4. Remove the Needle Valve from the ventilator from the inside.

Optical Encoder (Control Set) - 56060-30011

1. Perform the procedure to remove the following assembly:
Control PCB
2. Remove the knob from the control panel using an allen wrench.
3. Remove the mounting nut from the front of the ventilator.
4. Remove the Optical encoder through the inside of the ventilator.
5. Assemble the encoder as shown in Figure 8-9.

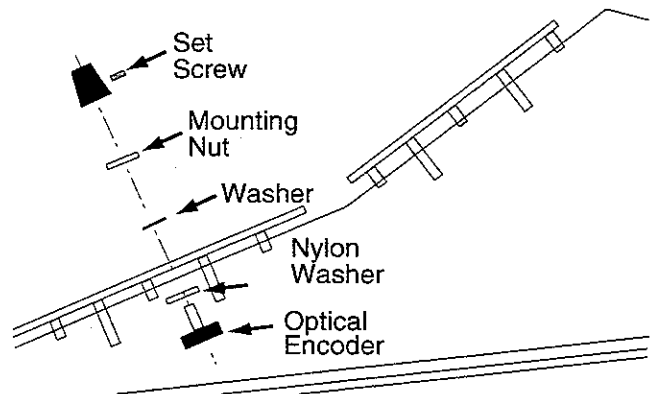
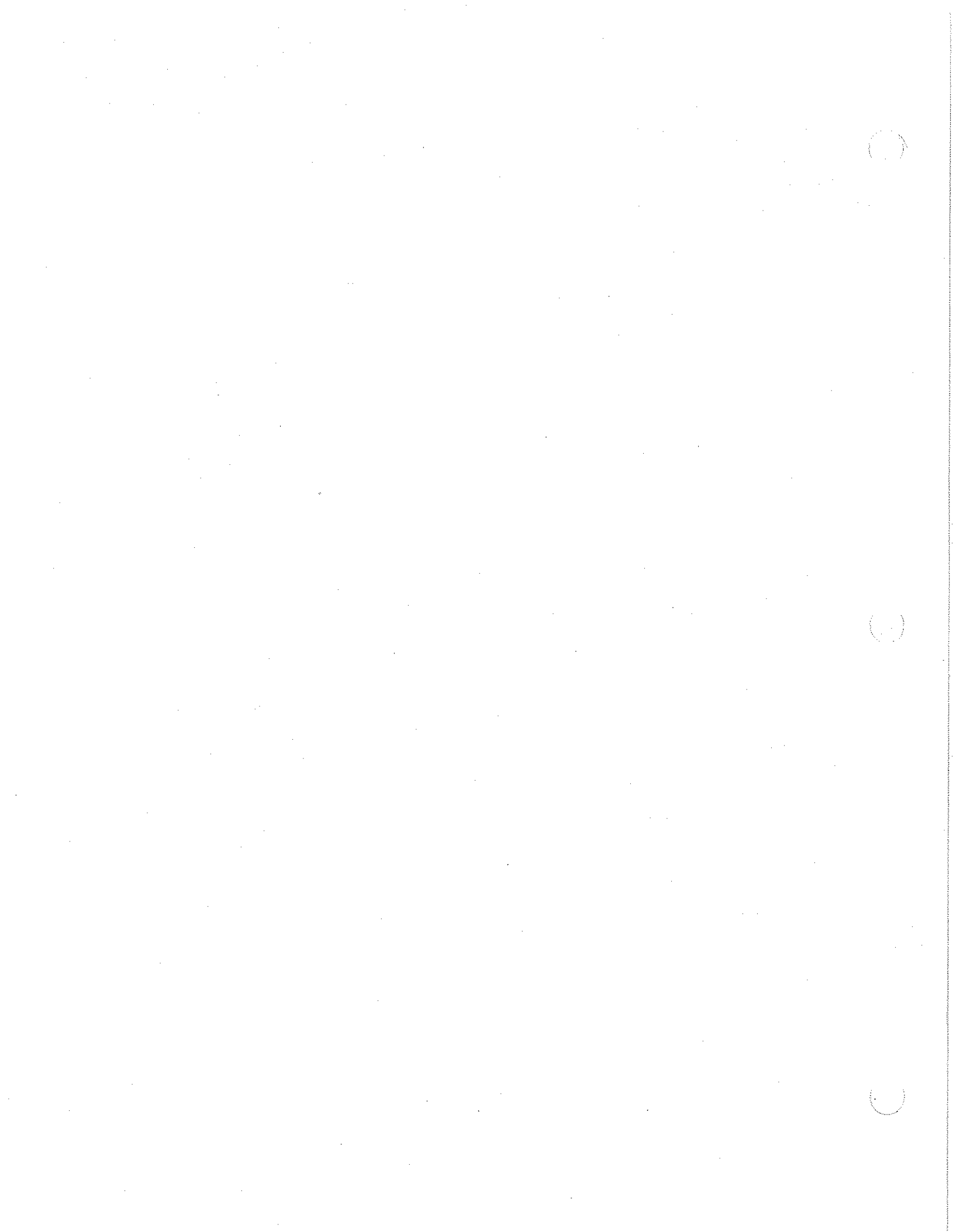

Figure 8-9
Optical Encoder Assembly

Optical Encoder (Monitor Set) - 56060-30011

1. Remove the knob from the Console using an allen wrench.
3. Remove the mounting nut from the front of the ventilator.
4. Remove the Optical encoder through the inside of the ventilator.
5. Assemble the encoder as shown in Figure 8-9.



Section 9

BEAR® 1000 Ventilator

Preventive Maintenance Procedure

Procedures.....	1
Exterior Inspection.....	1
Filter Replacement.....	1
Ground Resistance test	2
Current Leakage.....	2

()

()

()

RECOMMENDED SERVICE PROCEDURE

Preventive Maintenance on the BEAR® 1000 Ventilator should be completed a minimum of once each year. Maintenance is intended to be done in the hospital by a Bear Medical Systems Authorized Service Technician or a Bear Medical Systems Trained Hospital Service Technician.

Ventilator Preventive Maintenance includes:

- Visually inspecting and cleaning of external surfaces, controls, attachments and accessories.
- Opening and cleaning the interior of the unit.
- Visually inspecting all tubing, electrical wiring, connectors, and crimps, screws, nuts and hardware. Checking the general condition of all other internal components or assemblies.
- Replacing the Air and O2 filters.
- Replacing the Air and O2 inlet bowls and seals.
- Replacing the ambient air intake filters.
- Pneumatic and electronic verification and calibrating if required.
- Performing the Operational Verification Procedure.

CAUTION

Before using any test equipment (Electronic or Pneumatic) for calibration procedures (other than Operational Verification), the accuracy of the instruments must be certified by a testing laboratory. The laboratory master test instruments must be traceable to the U.S. Bureau of Standards or Equivalent. When variance exist between indication and actual values, the calibration curves) provided for each instrument by the testing laboratory) must be used to establish the actual correct values. This certification should be performed at least once every six months. More frequent certification may be required based on usage and environment.

EQUIPMENT REQUIRED

In addition to the equipment and supplies specified in the Calibration Section of this manual, the following will be required to perform the preventive maintenance:
50000-13001 PM Kit containing the following parts:

- Gas Inlet Filters (2 each) 52000-01144
- Bowl Kit (2 each w/ seals) 52000-01145
- Ambient Air Filter (2 each) 51000-08655

BIO-TEK Digital Safety Analyzer Model 170 or equivalent.

EXTERIOR INSPECTION

1. Turn off the ventilator and disconnect from AC power and pressurized gas at the wall sources.

CAUTION

Do not use Methyl Ethyl Ketone (MEK) or Tricloroethylene, as Damage to surfaces will result. Do not allow any liquid to spill or drip into the Ventilator.

2. Clean the exterior of the unit with water or a solution of 70% Isopropyl Alcohol solution only. Wipe all surfaces with a soft cloth or disposable wipe moistened in the cleaning solution.
3. Inspect the exterior surfaces of the ventilator for broken or loose knobs. Check the display panel for scratches, cracks and alignment of LED indicators. Check all front and rear panel fittings, circuit breakers and accessories for security. Check the AC electrical cord and plug for damage. Record the reading of the hour meter on the maintenance check list.
4. Replace the ambient air intake filters at the rear of the ventilator.
5. Remove the bowl from the Air Water Trap (Figure 9-1).

WARNING

When replacing air/O2 inlet filters, mark and remove one and only one fitting at a time. Replace the filter and return the fitting to its original location before removing the second fitting. Failure to follow this procedure may result in injury, including death, to the patient.

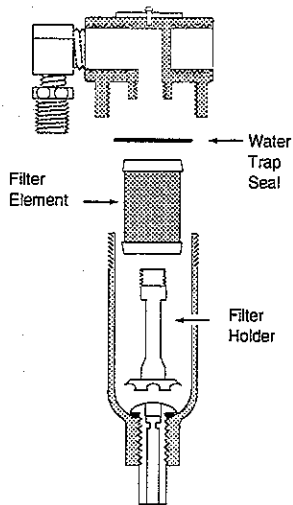

**Figure 9-1
Water Trap**

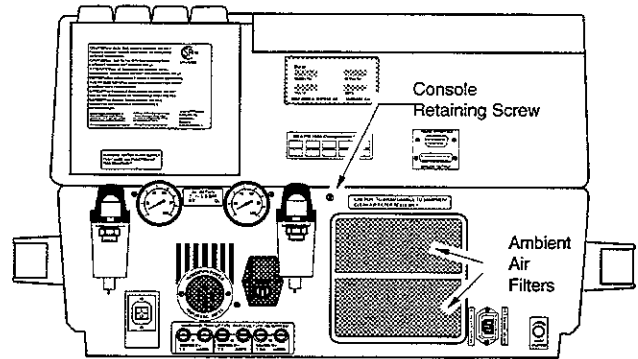

**Figure 9-2
Ventilator Rear View**

6. Remove the seal from the Water Trap housing using a small pocket screwdriver and discard.
7. Install the new seal from the kit.
8. Turn the filter holder counterclockwise and remove from housing. Discard old filter element (Figure 9-1).
9. Install the new filter element as illustrated on the Water Trap housing and tighten.
10. Install new bowl on the housing of the water Trap.
11. Repeat the procedure for the Oxygen water trap.

CAUTION

The circuit boards are subject to damage by static electricity. Do not touch components, circuit, or connector fingers with hands. Handle only by edges.

INTERIOR INSPECTION

1. Open the Ventilator by removing the console retaining screw (Figure 9-2).
2. Vacuum all surfaces inside the ventilator. Be sure to reach areas around connectors, circuit boards and pneumatic assemblies.

3. Visually inspect for any overheated components, loose connectors, damaged wires or tubing, kinked tubing, loose ribbon cables, loose or missing hardware, signs of water or other residue inside Tygor tubing, loose Tywraps, poor connector crimps or loose fasteners.

Specifications

Current leakage – 100µA maximum (per UL 544)
Ground resistance – 0.1 ohms at 25.0 A (per UL 544)

CALIBRATION AND VERIFICATION PROCEDURE

Verify the Power Supply Voltages per Section 7, Page 2, Error code E39.

Perform the following Calibration and / or Calibration Verification Procedures as described in the Calibration Section, Section 5 of the BEAR® 1000 Maintenance Manual.

1. Proximal Pressure Transducer Calibration
2. Differential Pressure Transducer Calibration
3. Machine Pressure Transducer Calibration
4. FCV Pressure Transducer Calibration
5. Air and O₂ Transducer Calibration
6. D/A Converter Calibration
7. Exhalation Valve Regulator Calibration
8. Inlet Check Valves and Air/ O₂ Calibration
9. Nebulizer Calibration

GROUND RESISTANCE TEST

Perform a ground resistance check (always follow manufacturer's instructions for test equipment operation).

1. Connect a properly functioning leakage and grounding tester between the ground connection and the hospital grade AC plug (middle lug) and the chassis of the ventilator (any unpainted exposed metal part).
2. With the tester connected and operating, there should be no more than 0.10 ohms resistance between the plug ground connector, and the ventilator chassis ground.

CURRENT LEAKAGE TEST

Perform a current leakage test (always follow manufacturer's instructions for test equipment operation).

1. Connect the ventilator to a properly functioning current leakage tester.
2. Turn Mode switch to CPAP and tester on.
3. Current leakage should be less than 100 microamps, grounded and ungrounded.

OPERATIONAL VERIFICATION PROCEDURE

Perform the Operational Verification Procedure (OVP), Section 3, after the Preventive Maintenance Procedure has been performed to assure that the ventilator is functioning properly. Complete an Operational Verification Procedure Checklist form and attach it to the PM Checklist form. See the OVP for specific instructions.

BEAR® 1000 VENTILATOR PREVENTIVE MAINTENANCE CHECK LIST

BEAR® 1000 Serial Number _____ Hour meter reading _____ Today's date _____

Service Location _____	Service organization _____
Address _____	Address _____
City, State, Zip _____	City, State, Zip _____
Contact _____	Service Person _____
Phone (____) _____	Phone (____) _____

VERIFICATION STEPS

STEP	PASS	FAIL	STEP	PASS	FAIL
Dust Filter	<input type="checkbox"/>	<input type="checkbox"/>	Air & O2 Transducers Calibration	<input type="checkbox"/>	<input type="checkbox"/>
Air and O2 Inlet Filters	<input type="checkbox"/>	<input type="checkbox"/>	D/A Converter Calibration	<input type="checkbox"/>	<input type="checkbox"/>
Interior Inspection	<input type="checkbox"/>	<input type="checkbox"/>	Exhalation Valve Regulator Calibration	<input type="checkbox"/>	<input type="checkbox"/>
Vacuum Interior	<input type="checkbox"/>	<input type="checkbox"/>	Inlet Check Valves & Air / O2 Calibration	<input type="checkbox"/>	<input type="checkbox"/>
Power Supply Verification	<input type="checkbox"/>	<input type="checkbox"/>	Nebulizer Calibration	<input type="checkbox"/>	<input type="checkbox"/>
Proximal Pressure Transducer Calibration	<input type="checkbox"/>	<input type="checkbox"/>	Ground Resistance	<input type="checkbox"/>	<input type="checkbox"/>
Differential Pressure Transducer Calibration	<input type="checkbox"/>	<input type="checkbox"/>	Current leakage	<input type="checkbox"/>	<input type="checkbox"/>
Machine Pressure Transducer Calibration	<input type="checkbox"/>	<input type="checkbox"/>	Perform OVP	<input type="checkbox"/>	<input type="checkbox"/>
FCV Pressure Transducer Calibration	<input type="checkbox"/>	<input type="checkbox"/>			

WARNING

Do not release the ventilator for use if it does not pass all of the procedures specified in the checklist. To do so could result in personal injury including death or property damage. Refer the ventilator to a Bear Medical Service Technician or a Bear Medical Systems trained service technician for appropriate repair and/or calibration.

Signature _____

Section 10

BEAR® 1000 Ventilator

Parts List

Accumulator	51000-08623	Flow Control Valve Assembly.....	51000-08520
Alarm Loudness Assembly	52000-08717	Harness Inlet Power	51000-08715
Analog Output Cable Assembly.....	51000-08609	Hour Meter Cable Assembly.....	51000-08610
Auto Zero Solenoid Valve Assembly	51000-08718	Inlet Manifold Assembly	51000-08622
Buzzer Assembly	51000-08608	Jet Pump Assembly.....	51000-08559
Cable Assembly Control PCB to EPI.....	51000-08615	Nebulizer Regulator Assembly.....	51000-08724
Cable Control to Monitor Assembly	51000-08662	Needle Valve.....	51000-08617
Cable External Flow.....	51000-08614	Oxygen Blender.....	51000-08562
Cable Monitor to Control Assembly	51000-08616	PCB Assembly Power Supply Module	51000-08671
Cable Power Logic	51000-08611	PCB Control Assembly.....	51000-08674
Cable Power Supply to Caps.....	51000-08633	PCB External Flow Sensor Assembly.....	51000-08625
Cable Power Supply to Control PCB	51000-08631	PCB Monitor Assembly.....	51000-08676
Cable Power Supply to EPI	51000-08630	PCB Power Supply Hold Up Capacitor	
Communications Port Assembly.....	51000-08600	Assembly	51000-08681
Diaphragm Mounting Base Assembly.....	51000-08580	RS232 Output Cable Assembly	51000-08629
Electro-Pneumatic Interface PCB		Shut Off Solenoid Valve	51000-08716
Assembly	51000-08670	Solenoid, Blender Bleed Valve Assembly	51000-08721
EFS Internal Cable assembly	51000-08632	Solenoid, Exhalation Valve Assembly.....	51000-08721
Exhalation Control Valve Manifold.....	51000-08591	Solenoid, Nebulizer Valve Assembly	51000-08722
Exhalation Valve Bulkhead Assembly	51000-08635	SOPR Valve Assembly.....	51000-08540
Exhalation Valve Diaphragm	51000-08782	SOPR Valve Diaphragm.....	51000-07475
Exhalation Valve Regulator Assembly.....	51000-08723	Transformer.....	51000-08716
Fan Assembly	51000-08609		

Flow Sensor # 50000-09900 cost \$295.⁰⁰
 X Exhalation Valve # ~~50000-08602~~ 50000-08602 cost \$254.⁰⁰
 X Diaphragm Mounting Base Assembly # 51000-08580 cost 235.⁰⁰
 X Exhalation Valve Diaphragm # 51000-08782 cost 109.⁰⁰ (part of 3)

2

3

4

Section 11

BEAR® 1000

Repacking and Shipping Instructions

GENERAL:

The packaging system for the BEAR® 1000 Ventilator has been designed to provide a high degree of protection against shipping damage.

All shipments of BEAR® 1000 Ventilators should be made using the packaging system P/N 51000-08896.

Bear Medical Systems, Inc., does not assume any liability whatsoever for any damage incurred in any product returned to our facilities by any means. The shipper and carrier are totally responsible for all damage and costs involved in transporting returned goods. If a package is damaged in shipment, your shipper and/or carrier should be notified within ten days of receipt of the shipment.

PACKAGING INSTRUCTIONS

NOTE

It is advisable that a shipping department or organization perform this procedure. A local freight company will usually pack the product at your facility for a small service charge.

The shipping carton (P/N 51000-08896) consists of:

- 51000-08899 Accessory Carton
- 51000-06056 Anti-static Bag 26"x22"x44"
- 51000-08901 Cavity pack-bottom
- 51000-08900 Cavity pack-top
- 51000-08904 Shipping Carton

PROCEDURE:

1. Place a large plastic bag over the ventilator.
2. Attach a shipper to the plastic bag with tape.
3. Place the ventilator in the carton, align the ventilator so it slides into the cavity-pack bottom.
4. Align the cavity-pack top so it slides in place on top of ventilator.
5. Seal the box top flaps with heavy duty packaging tape.

