

Infant Flow[®] SiPAP[™] Model M675

Service manual



CardinalHealth

© 2008 Cardinal Health

All rights reserved. No part of this document may be reproduced, stored, or transmitted in any form or by any means without the written permission of Cardinal Health, except as specifically permitted under the copyright laws of the United States of America.

Infant Flow is a registered trademark and SiPAP is a trademark of the Cardinal Health group of companies. Other brands and their products are trademarks of their respective holders and should be noted as such.

USA

Cardinal Health
Respiratory Technologies
1100 Bird Center Drive
Palm Springs, California 92262-8099

Telephone: 800.231.2466

+1.714.283.2228

Fax: +1.714.283.8493

Authorized European Representative

Cardinal Health Germany 234 GmbH
Leibnizstrasse 7
97204 Hoechberg
Germany

Telephone: +49.931.4972.0

Fax: +49.931.4972.423

cardinalhealth.com



Literature number: 675–120 Revision E

Revision History

Date	Revision	Pages	Changes
September 2003	675-120(1)	All	Release
November 2004	B	All	Release manual in VIASYS Healthcare template using VIASYS Healthcare Respiratory Care nomenclature.
December 2004	C	Title page, 19, 30, 39, 45, 50, 56, 57, 61, 62, 64, 65, 68, 69, 73, 75, 81–83, 86, 87, 88	<p>Revised per EO 27980.</p> <p>Removed the picture from the title page.</p> <p>Deleted the ESD warning from page 19.</p> <p>Removed "O2 Sensor" and added the word "measured" on page 30.</p> <p>Changed "O2 sensor" to "fuel cell" on pages 39, 45, 62, 68, 69, 73, 86, and 87.</p> <p>Replaced the O2 sensor row on page 50.</p> <p>Updated the error codes on pages 56 and 57.</p> <p>Replaced the warning on page 61.</p> <p>Changed the Fitting procedure on pages 64, 68, and 75.</p> <p>Changed step 6 on page 65.</p> <p>Added Addendum A – Oxygen Leak Test</p> <p>Changed Transducer Assy. to Transducer Interface on page 88.</p>
May 2005	D	All 4,8 63 67 69,70 71,72 74 83, 84, 85	<p>Revised per ECO 60329</p> <p>Update address/contact info</p> <p>Update battery remove/install procedure</p> <p>Added note for fuel cell disposal</p> <p>Update check valve assembly remove/install procedure</p> <p>Update water trap & restrictor remove/install procedure</p> <p>Delete redundant leak test</p> <p>Update list of service parts</p>
August 2008	E	vii x 18 20 27 41 43	<p>Updated company information</p> <p>Updated company information</p> <p>Corrected Table 2 and updated Table 3</p> <p>Updated Figure 6</p> <p>Updated Figure 10</p> <p>Updated the section "Diagnostics."</p> <p>Updated Table 6 starting on page 43</p>

Warranty

The Infant Flow® SiPAP is warranted to be free from defects in material and workmanship and to meet the published specifications for One (1) year from date of shipment.

The liability of Cardinal Health, (referred to as the Company) under this warranty is limited to replacing, repairing or issuing credit, at the discretion of the Company, for parts that become defective or fail to meet published specifications during the warranty period; the Company will not be liable under this warranty unless (A) the Company is promptly notified in writing by Buyer upon discovery of defects or failure to meet published specifications; (B) the defective unit or part is returned to the Company, transportation charges prepaid by Buyer; (C) the defective unit or part is received by the Company for adjustment no later than four weeks following the last day of the warranty period; and (D) the Company's examination of such unit or part shall disclose, to its satisfaction, that such defects or failures have not been caused by misuse, neglect, improper installation, unauthorized repair, alteration or accident.

Any authorization of the Company for repair or alteration by the Buyer must be in writing to prevent voiding the warranty. In no event shall the Company be liable to the Buyer for loss of profits, loss of use, consequential damage or damages of any kind based upon a claim for breach of warranty, other than the purchase price of any defective product covered hereunder.

The Company warranties as herein and above set forth shall not be enlarged, diminished or affected by, and no obligation or liability shall arise or grow out of the rendering of technical advice or service by the Company or its agents in connection with the Buyer's order of the products furnished hereunder.

Limitation of Liabilities

This warranty does not cover normal maintenance such as cleaning, adjustment or lubrication and updating of equipment parts. This warranty shall be void and shall not apply if the equipment is used with accessories or parts not manufactured by the Company or authorized for use in writing by the Company or if the equipment is not maintained in accordance with the prescribed schedule of maintenance.

The warranty stated above shall extend for a period of One (1) year from date of shipment, with the following exceptions:

1. Components for monitoring of physical variables such as temperature, pressure, or flow are warranted for ninety (90) days from date of receipt.
2. Elastomeric components and other parts or components subject to deterioration, over which the Company has no control, are warranted for sixty (60) days from date of receipt.
3. Internal batteries are warranted for ninety (90) days from the date of receipt.

The foregoing is in lieu of any warranty, expressed or implied, including, without limitation, any warranty of merchantability, except as to title, and can be amended only in writing by a duly authorized representative of the Company.

Contents

Revision History	iii
Warranty	iv
Limitation of Liabilities.....	iv
Notices.....	vii
EMC Notice.....	vii
MRI Notice.....	vii
Intended Use Notice	viii
Regulatory Notice	viii
Classification.....	viii
Declaration of Conformity Notice	ix
Chapter 1 – Product Description.....	1
Chapter 2 – Product Specifications	3
Modes	3
Controls	3
Monitors	3
Alarms.....	4
Pneumatic Supply.....	4
Electrical Supply	4
Atmospheric & Environmental	5
Physical	5
Chapter 3 – Warnings and Cautions.....	7
Terms.....	7
Warnings.....	7
Cautions	9
Chapter 4 – System Construction.....	11
Touch Screen	15
Alarm Conditions	17
Diagnostic Screen.....	17
Chapter 5 – Operation	19
Gas Flow.....	19
Electronic Functions	22
Electrical Layout	23
Fault Management.....	24
Chapter 6 – Operation	25
Preparing and Connecting the Equipment.....	25
Switching On the IFSD	28
Alarms Test.....	29
Infant Flow® SiPAP™ User Verification Test Checklist	31
Setting Up the Equipment.....	32
Setting the NCPAP Parameters.....	33

Setting the BiPhasic Parameters	34
Setting the Triggered BiPhasic Parameters	35
Calibration	37
Giving a Manual Timed Sigh	37
Operation Without Electrical Power	37
Fault Indications	38
Diagnostics	44
Chapter 7 – Maintenance	51
Cleaning	51
Maintenance	51
General	51
Maintenance Frequencies	52
Removal and Fitting of Case	53
Removal and Fitting of Battery	54
Removal and Fitting of Oxygen Filter	55
Removal and Fitting of Fuel Cell Filter/Restrictor	56
Removal and Fitting of the Fuel Cell	57
Removal and Fitting of Blender and Components	58
Removal and Fitting of Water Trap Filter	61
Removal and Fitting of Case Bleed Filtered Restrictor	62
Removal and Fitting of PA Solenoid Valve	63
Firmware Reload/Upgrade	63
Chapter 8 – Explanation of Symbols	65
Appendix A – Oxygen Leak Test	69
Appendix B – Product Configurations	73
Non-US Configuration Parameters	73
US Configuration Parameters	73
Appendix C – Spare Parts	75
Appendix D – Pneumatics Assembly	79
Glossary	81

Notices

EMC Notice

This equipment radiates and is susceptible to radio frequency energy. If not installed and used in accordance with the instructions in this manual, electromagnetic interference may result. The equipment has been tested and found to comply with the limits set forth in BS EN60601-1-2 for Medical Electrical Equipment Part 1-2: General requirements for safety-collateral standard. Electromagnetic compatibility – requirements and tests. These limits provide reasonable protection against electromagnetic interference when operated in the intended use environments (e.g. hospitals) described in this manual.

This device is also designed and manufactured to comply with the following standards;

Safety: UL 60601-1: 2003 Medical Electrical Equipment, Part 1: General Requirements for Safety.

CAN/CSA C22.2 No 601.1-M90, Medical Electrical Equipment - Part 1: General Requirements for Safety including C22.2 No. 601.1S1-94 (IEC601-1, Amendment 1:1991) Supplement No. 1-94 to CAN/CSA 22.2 No. 601.1-M90

With regards to Electrical Safety:

Class 1 equipment

Contains type BF patient applied parts

Continuous Operation

MRI Notice

This equipment contains electromagnetic components whose operation can be affected by intense electromagnetic fields.

Do not operate this device in a MRI environment or in the vicinity of high-frequency surgical diathermy equipment, defibrillators, or short-wave therapy equipment. Electromagnetic interference could disrupt the operation of the device.

Intended Use Notice

The Infant Flow[®] SiPAP, consisting of a Driver and Generator plus NCPAP Prongs and Masks, is a medical device intended for the provision of Bi-Level CPAP to produce a sigh. This system is for use in Hospital, Hospital Type facilities and intra-Hospital transport environments and is indicated for the treatment of Newborn and Infant patients.

Operators of this equipment and Service Engineers are required to read and thoroughly understand the contents of this manual before using or maintaining the equipment.

This manual is intended for use by a competent, fully qualified Service Engineer. It includes a description of the unit and how it works. It also contains operating and diagnostic procedures and maintenance instructions. For usage of associated equipment, refer to the Manufacturer's literature.

Regulatory Notice

Federal law restricts the sale of this device except by or on order of a physician.

Classification

Type of Equipment: Medical Equipment, Class 1 and internally powered, IPX1 Protected, and uses type BF applied parts. Equipment is not suitable for use in presence of flammable anesthetics.

Declaration of Conformity Notice

This medical equipment complies with the Medical Device Directive, 93/42/EEC, and the following Technical Standards, to which Conformity is declared:

Council Directive(s): MDD 93/42/EEC Annex II (excluding section 4)

Safety: EN 60601-1, EN 794-1

EMC: EN 60601-1-2:2001

Conformity Assessment: MDD Annex II

Quality System: ISO 13485

EU Notified Body: BSI (Reg. No. 0086)

Device Classification: IIb



EU Notified Body:

BSI (Reg. No. 0086)

Trade names:

Infant Flow SiPAP

Manufactured by:

Cardinal Health
22745 Savi Ranch Parkway
Yorba Linda, CA 92887, USA

If you have a question regarding the Declaration of Conformity for this product, please contact Cardinal Health.

Infant Flow[®] SiPAP[™]
Model M675

Chapter 1 – Product Description

The Infant Flow[®] SiPAP is a non-invasive form of respiratory support designed for use in hospital environments such as Neonatal and Pediatric Intensive Care Units. It can also be used when transporting patients within the hospital environment.

The Infant Flow[®] SiPAP is currently available in a Plus or Comprehensive configuration. The Plus configuration provides NCPAP and time triggered, BiPhasic modes with and without breath rate monitoring. The Comprehensive configuration offers these features plus patient BiPhasic mode with apnea backup breaths. The Infant Flow[®] SiPAP comes standard in all configurations with an LCD touch screen display, pressure time waveform graphics, integrated patient monitoring, alarms for high and low pressure and FiO₂ and up to 2 hours of backup battery power.

As a result of the unique patented design, the Infant Flow[®] SiPAP has been proven to provide the most stable CPAP at the lowest work of breathing for patients compared to other devices. The outstanding performance of the Infant Flow[®] SiPAP is irrespective of patient demand or expiratory flows. This system has been designed and tested to perform optimally when used only with accessories available from Cardinal Health. These accessories include circuits and generators, prong and mask patient interfaces and bonnets.

Infant Flow[®] SiPAP Features

The expanded capabilities of the Infant Flow[®] SiPAP Plus and Comprehensive configurations allow for applications to broader range of patients who may otherwise not be candidates for non-invasive respiratory support.

NCPAP – allows for continuous positive airway pressure based on clinician set pressure. Breath rate monitoring/alarm can be activated in this mode.

BiPhasic - allows for time triggered pressure assists to be delivered based on clinician set inspiratory time, rate, and pressure criteria. Breath rate monitoring/alarm can be activated in this mode.

BiPhasic tr* - allows for patient triggered pressure assists to be delivered based on clinician set inspiratory time and pressure criteria. Breath rate monitoring/alarm, and Apnea backup breaths are automatically active in the mode.

Patented Infant Flow[®] Generator - The Infant Flow[®] Generator is a fluidic device for the generation of consistent infant nasal CPAP with a low work of breathing compared to other devices.

Fully integrated alarms packages – . Supply gases failure, High Patient Pressure, Low patient pressure, high and low delivered Oxygen concentration, change from AC to DC power source, low and flat battery charge status and Low breath rate/apnea alarm.

Battery Backup – Up to 2 hours of battery backup allows for intra-hospital transport. Clear indicators are provided for power supply in use (AC or DC), and battery charge level.

Screen Lock - After 120 seconds of no screen inputs, the screen changes to the Locked Screen to prevent inadvertent changes. Upon activation of a high priority alarm the screen changes to an unlocked state to allow for immediate interventions as required.

Table 1 - Functions and Accessories

Functions & Accessories	Plus	Comprehensive*
NCPAP	•	•
NCPAP with breath rate monitoring and alarm	•	•
BiPhasic	•	•
BiPhasic with breath rate monitoring and alarm	•	•
BiPhasic tr*		•
Internal Battery	•	•
Manual Breath	•	•
Apnea Back up rate		•
Screen lock	•	•
Prioritization of alarms	•	•

*Comprehensive configuration not available for sale in the United States

CAUTION

The Infant Flow SiPAP™ has been designed and tested as a complete system using Infant Flow™ accessories. Only accessories approved for use should be used. If in doubt, please contact your local Cardinal Health representative.

Chapter 2 – Product Specifications

Modes

- NCPAP
- NCPAP with breath rate monitoring and low rate alarm
- BiPhasic (time triggered)
- BiPhasic (time triggered) with breath rate monitoring and low rate alarm
- BiPhasic tr (patient triggered) with breath rate monitoring, low breath rate alarm, and apnea back up

Controls

- Inspiratory Time (Ti): 0.1-3.0 seconds
- Rate (R): 1-120 (Comprehensive only. The comprehensive configuration is not available for sale in the United States.)
- Rate (R): 1-54 (Plus only)
- Apnea Interval (T_{apnea}): 10-30 seconds, 5 second intervals (Comp* only)
- Apnea Interval (T_{LBR}): 10-30 seconds, 5 second intervals (Plus only)
- NCPAP/Pres Low flowmeter: 0-15L/min, accuracy +/- 15% of selected output
- NCPAP/Pres High flowmeter: 0-5L/min, accuracy +/- 15% of selected output
- Manual Breath: X 1
- Rate monitoring on/off: NCPAP
- %O₂: 21 - 100% - accuracy +/-3%

Monitors

- CPAP
- PEEP
- MAP
- PIP
- %O₂
- I:E ratio
- Spontaneous rate (Rs)
- Battery charge level

Alarms

- High airway pressure – 3 cmH₂O above measured airway pressure
- High circuit pressure – maximum 11 cmH₂O in time triggered Biphasic mode
- High circuit pressure – maximum 15 cmH₂O in patient triggered Biphasic tr mode (Comprehensive only. The comprehensive configuration is not available for sale in the United States.)
- Low airway pressure – 2 cmH₂O below measured airway pressure or 1 cmH₂O if otherwise would be zero
- High and Low delivered Oxygen concentration +5% of setting
- Low breath rate alarm
- Low or Flat battery charge level
- Input gases failure
- Alarm volume (electronic alarms) 70 dBa at 1 meter

Pneumatic Supply

- **Patient Gas Outlet:** 15 mm standard taper fitting
- **Patient Pressure Input:** 4.5 mm Luer taper fitting
- **Gas Supply:** Nominal 4 bar or 60 psi, clean, dry medical air and oxygen
- **Range:** 2.8 to 6 bar (40 to 90 psi); maximum differential pressure 2 bar (30 psi)
- **Manometer:** Range 0 to + 20 cmH₂O, accuracy, ± 2% of span
- **Gas Connections:** Standard DISS or NIST connectors

Electrical Supply

- **Input Voltage:** 100-230 VAC
- **Input Frequency:** 50/60 Hz
- **Power Consumption:** 50 VA maximum
- **Fuse Rating For 220 V nominal operation:** “T” Type 2.5 A at 250 V
- **Device Housing Protection rating level:** IPX1
- **Battery Working Time:** 2 hours (from fully charged state)
- **Battery Charging Time:** max. 16 hours

Atmospheric & Environmental

- **Temperature Range-Operating:** 5 – 40° C
- **Storage:** 0 - 50° C
- **Relative Humidity -Operating:** 0 – 90% non-condensing
- **Storage:** 0 – 90% non-condensing

Physical

- **Dimensions (driver only)-(W x H x D)** 26 x38 x 23.5 cm / 10.25 x15 x 9.25 in
- **Weight (driver only)**-8.8 kg / 19.5 lb

Infant Flow[®] SiPAP[™]
Model M675

Chapter 3 – Warnings and Cautions

Please review the following safety information prior to operating the Infant Flow[®] SiPAP. Attempting to operate this equipment without fully understanding its features and functions may result in unsafe operating conditions.

Warnings and Cautions, which are general to the use of the device under all circumstances, are included in this section. Some Warnings and Cautions are also inserted within the manual where they are most meaningful.

Notes are also located throughout the manual to provide additional information related to specific features.

If you have a question regarding the installation, set up, operation, or maintenance of the device, contact technical support at Cardinal Health.

Terms

- WARNINGS** identify conditions or practices that could result in serious adverse reactions or potential safety hazards.
- CAUTIONS** identify conditions or practices that could result in damage to the ventilator or other equipment.
- NOTES** identify supplemental information to help you better understand how the ventilator works.

Warnings

- Whenever a patient is attached to respiratory care equipment, constant attendance is required by qualified personnel. The use of an alarm or monitoring system does not give absolute assurance of warning for every malfunction that may occur in the system. In addition, some problems may require immediate attention.
- The gas blender incorporated in this product is designed to mix medical grade air and oxygen only. Do not modify the inlets to accommodate other source gases such as anesthetic gases.
- Check that the water trap is empty before use and empty it frequently during use.
- Liquid water or other contaminants in either gas supply, particularly the air supply, may cause malfunction of this equipment and equipment connected to it.
- When filling a humidifier, do not move the stand. Moving or transporting the stand while refilling may cause the stand and equipment to over balance.

- Do not use conductive patient circuits with the Infant Flow SiPAP Driver.
- Nasal CPAP can cause nasal irritation, septal distortion, skin irritation and pressure necrosis. Observe the usage guidelines to minimize these complications.
- This device exhausts O₂ during normal operation. Oxygen vigorously accelerates combustion. To avoid fire hazard, do not place flammable materials or sources of heat close to the exhaust.
- Do not use the equipment without the exhaust tube fitted (refer to Figure 2).
- To reduce trip hazard, always ensure cable and tubes are restrained away from walking areas.
- The Abdominal Respiratory Sensor will not detect all forms of apnea. Independent monitoring should always be used with this device.
- If the unit is shelf mounted, ensure that the unit is stable and that hoses and cables are restrained to avoid hazard of toppling.
- This equipment is not suitable for use in the presence of a flammable anesthetic mixture.
- The NCPAP Pres High flowmeter must be adjusted to zero when not required for the patient.
- Under extreme conditions (minimum supply pressure and maximum gas demand, including auxiliary output) output flow rates and delivered pressure may be reduced.
- Only use the supplied AC cable to connect to the power supply.
- Do not attach the Generator to the patient until the initial set up is complete.
- The  indicates a connection between the transducer interface and the unit. It does not indicate correct positioning of the Abdominal Respiratory Sensor.
- Calibration must only be done when the unit is not connected to the patient.
- Ensure the whistle sounds during gas connection. If not, the device may be faulty and should not be used. Refer to your Service Engineer.
- Verify that the displayed value for delivered FiO₂ corresponds to the value set on the blender. Refer to Faults and Indications.
- Oxygen vigorously accelerates combustion. To avoid explosion hazard, do not use any instrument or other equipment that may have been exposed to oil or grease contamination.

Cautions

- Federal Law (USA) restricts this device to sale by or on the order of a physician.
- The precision gas blender in this product may become non-functional or damaged if used without the protective water trap and filters provided.
- The power switch on this unit does not isolate the external power supply. Disconnect the power supply cable to ensure complete isolation.
- Before use, verify that this equipment has been authorized for use by a qualified person.
- The Infant Flow SiPAP™ has been designed and tested as a complete system using Infant Flow™ accessories. Only accessories approved for use should be used. If in doubt, please contact your local Cardinal Health representative.
- Where the integrity of the external protective earth conductor is in doubt, the equipment shall be powered by its internal power source (battery).
- Do not immerse any part of the IFSD in water or sterilize it with gas or steam.
- Ensure patient breathing circuit is replaced at regular intervals.

Infant Flow[®] SiPAP[™]
Model M675

Chapter 4 – System Construction

CAUTION

Where the integrity of the external protective earth conductor is in doubt the equipment shall be powered by its internal power source (battery).

The IFSD is AC powered with an integral rechargeable DC battery that provides power for up to two hours without any interruption of performance or function. If the AC power supply fails or is disconnected, the IFSD automatically switches to battery power and gives an audio and visual alarm.

The IFSD is enclosed in a case with Operator controls and input connectors on the front and rear panel. The front panel is shown in Figure 1. The back panel is shown in Figure 2. The case incorporates non slip feet for table top use or must be fitted to a dedicated stand. The major components within the casing are:

- a gas module
- an electronics module
- a front panel module
- a patient trigger module
- a firmware module

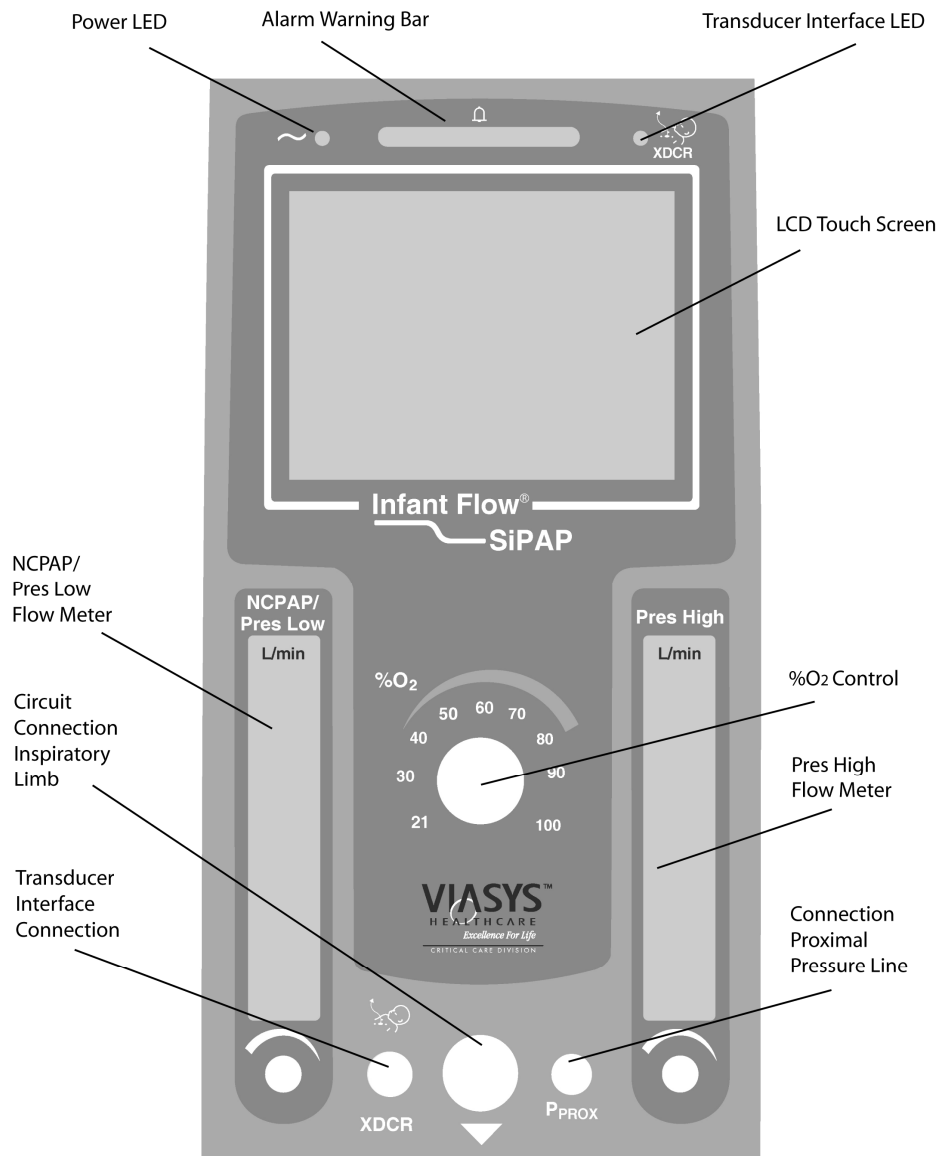

Figure 1 - IFSD Front Panel

Gas Module

The function of the gas module is to take air and oxygen, blend them into the required mixture and deliver this mixture to the patient at the prescribed flow rate. The gas module also measures the oxygen concentration, measures the patient pressure, provides an auxiliary gas outlet (optional) and provides switched Biphasic flow.

The main components are an air/oxygen blender, a flow manifold, a vent valve, an exhaust manifold with alarm whistle, NCPAP Pres low and NCPAP Pres high flowmeters, and a valve/sensor PCB. The inlet gas connections are on an interchangeable inlet block to allow for different gas fittings. The exhaust manifold discharges gas to the outside of the case and is positioned away from the electrical connectors and switch to reduce any potential explosive hazard.

Electronics Module

The function of the electronics module is to power the unit either by AC mains supply or DC emergency battery supply, to control the gas module and read the gas module sensors. The main components are a power supply unit, a rechargeable battery, a main processor PCB, LED PCB, Valve/Sensor PCB and a LCD screen (touch screen). The LCD screen includes a back-light which is always on when the IFSD is powered. The touch screen displays information and receives inputs from the Operator via the touch screen keyboard.

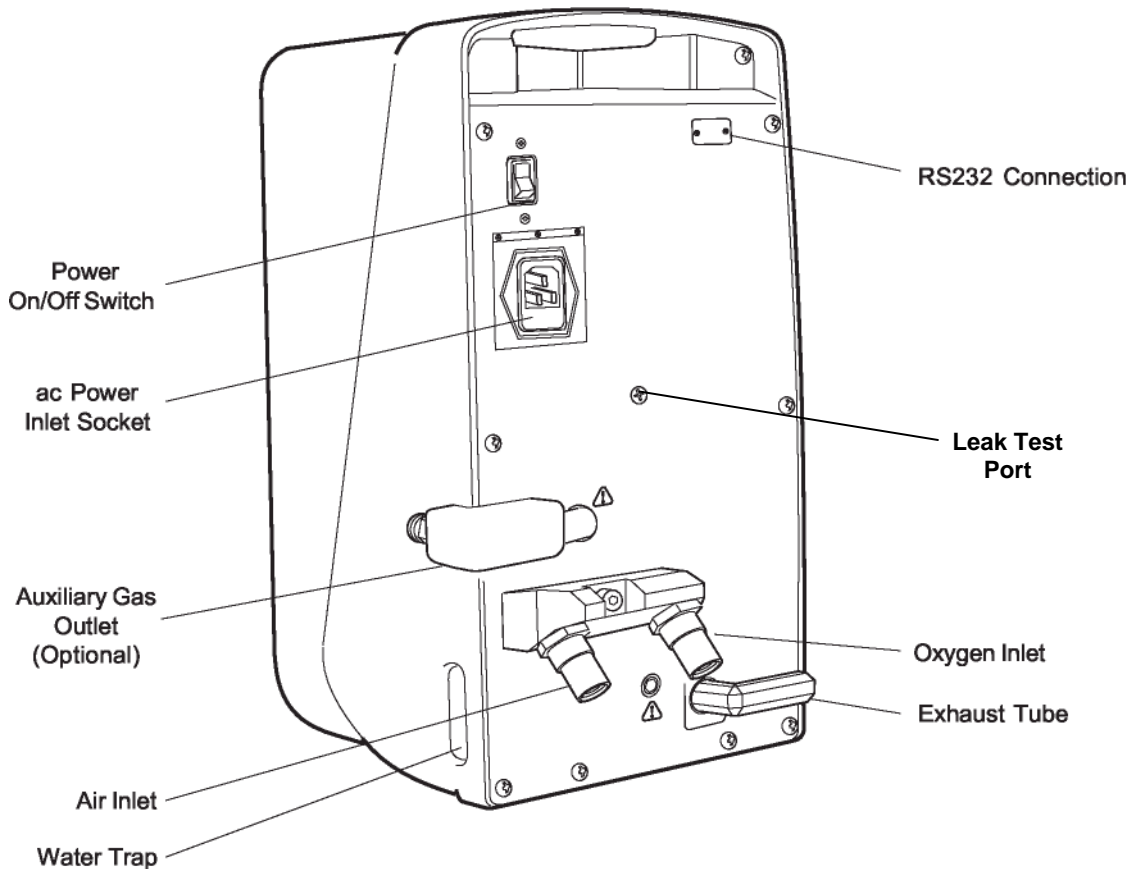

Figure 2 - IFSD Back Panel

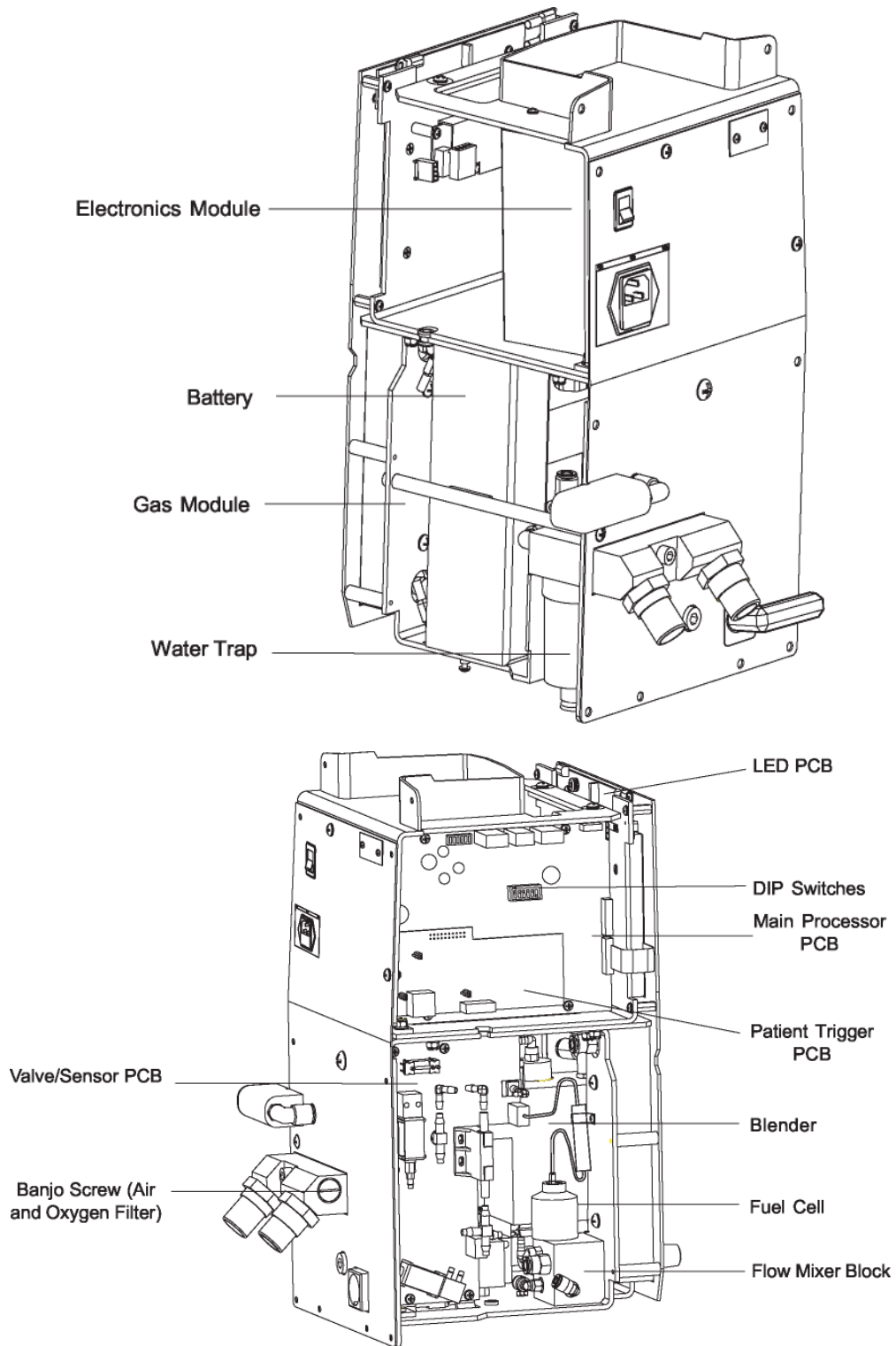

Figure 3 -IFSD Internal Components

Front Panel Module

The function of the front panel module is to house the gas and electrical connections to the patient, Operator controls and indicators. The module consists of a front panel plate, the touch screen with key pad, flowmeters and FiO₂ control, patient connectors and indicators and an ambient light sensor. The backlight on the touch screen is decreased if the ambient light sensor detects a low ambient light level and increased if it detects a high ambient light level.

The green Power light is always on when AC power is connected to the unit.

The Alarm Warning Bar  flashes red to indicate an alarm.

Patient Trigger Module (Plus and Comprehensive Models)

The patient trigger module consists of a PCB which plugs into the main processor PCB. Its function is to detect patient breaths and apnea and give this information to the main processor in the electronics module. The main processor uses the signals from the patient trigger module to instruct the biphasic pressure control to provide a timed sigh to the patient.

Firmware Module

The firmware module is the unit's embedded software. Its function is to instruct the microprocessor how to control the unit and to interact with the Operator.





Touch Screen

The touch screen provides the Operator with a series of screens with icons to enable settings, calibration and fault diagnosis. The Start Up Screen is shown in Figure 4. The display includes a status bar which incorporates a battery status, mode indicator, alarm button and patient trigger indicator. The center part of the display shows icons which relate to the function being selected or performed. The display also includes a key pad with six keys. The icon in each key changes depending on the function being performed.

Battery Status and Charging Indicator

If the battery status shows three bars or less, the display flashes alternately between red bars on a white background and a pink background.

Alarm Button

The alarm button alerts the Operator to fault conditions. An audible alarm is activated at the same time. In the unalarmed condition the button is green . In the high-priority alarm condition, the button flashes  red and an audible alarm is heard. If the alarm button is pressed (to silence the audible alarm), the button changes to  and flashes red. In a medium-priority alarm condition, the button flashes  yellow and an audible alarm is heard. In a low-priority

alarm condition, the button is solid  yellow with an audible alarm. If any alarm condition resets itself, the yellow alarm bar remains to alert the clinician of a previous problem.

Caution/Information

The Caution/Information icon alerts the Operator to read this manual. It flashes during an alarm condition.

Mode Indicator

The Mode Indicator shows four question marks when in Start up or Adjust and changes to show the applicable mode in use (e.g. NCPAP).

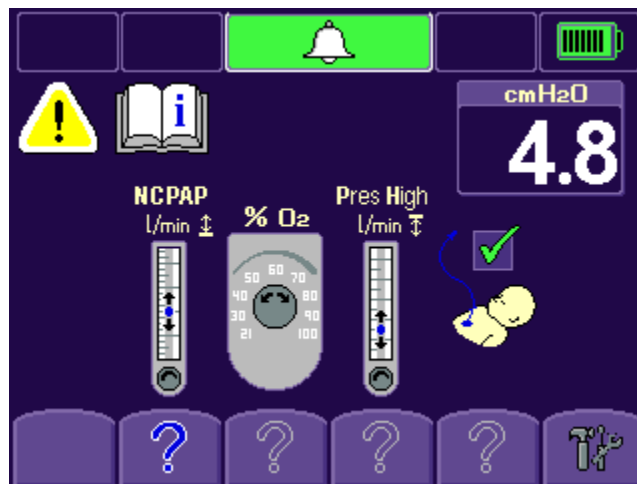



Figure 4 - Touch Screen Display – Start Up

Patient Trigger Indicator (Plus and Comprehensive Models)

The Patient Trigger indicator changes to  when the transducer interface is connected and ready to be connected to the patient and indicates a  when the transducer interface is not connected.

Alarm Conditions

Audible and visible alarm indications are given to alert the Operator to specified conditions that affect the operation of the unit. The electronic alarm limits are automatically set after two minutes without Operator inputs but the Operator can manually set the alarm parameters for certain conditions if required. The IFSD has the following alarms:

- an audible Whistle which sounds a constant tone when the gas imbalance limits are exceeded.
- an audible Alarm which sounds a constant tone or two different intermittent tones; medium or high level (medium level sounds beep.beep.beep every 15 seconds and high level sounds beep.beep.beep beep beep every 10 seconds).
- a visual Warning Bar which flashes red continuously, flashes intermittently or comes on continuously.
- an Alarm Button on the touch screen status bar which flashes continuously.

Other indications are given to indicate the status of the condition. Refer to Table 2 for alarms and indications for specified conditions.

Diagnostic Screen

A diagnostic screen is provided for low level calibration, test procedures for valves and an error log. Figure 5 shows the screen display. *Labeling of Diagnostic screen will be the same regardless of configuration.*

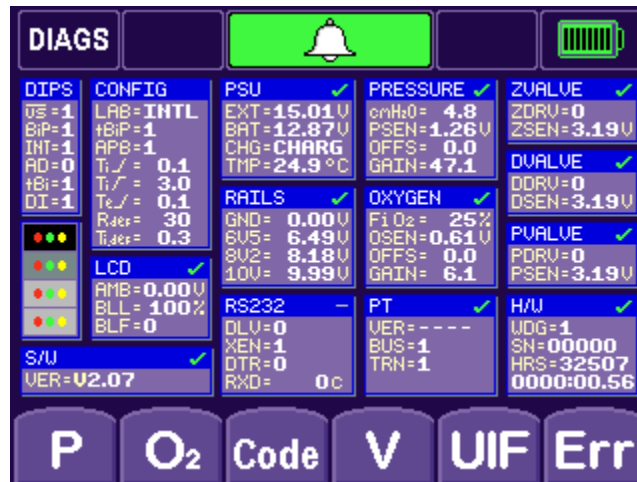





Figure 5 - Diagnostic Screen

Table 2 - Diagnostics Screen Boxes

Box	Description
DIPS	The DIPS box shows the position of the DIP switches on the main processor PCB. Position 1 is on and 0 is off.
CONTRAST INDICATOR	The contrast indicator box is for use in the factory for setting the screen contrast.
CALIBRATION INDICATOR	The calibration indicator box shows  during calibration, a  when successfully completed and a  if the calibration fails.





The following display boxes show  if the values are within the set parameters, a  if the values are outside the set parameters, a  if the function is not calibrated and a  if the function is disabled on the DIP switch.

Table 3 - Additional Diagnostics Screen Boxes

Box	Description
S/W	The S/W box shows the version and serial number of the loaded firmware.
H/W	The H/W box shows the status of the watchdog timer (WDG) and the EEPROM (E ² P).
PT	The PT box shows the status of the Patient Trigger module.
CONFIG	The CONFIG box shows the software configuration based on the DIP switch settings and requirements. LAB = INTL or US (controlled by DIP 3), which is the Comprehensive or Plus model; tBiP = 1 or 0 (controlled by DIP 2 and 5), which indicates Triggered BiPhasic is enabled (1) or disabled (2); APB = 1 or 0 (controlled by DIP 2), which indicates that Apnea BiPhasic is enabled (1) or disabled (0); The remaining symbols provide the default and ranges for inspiratory time, and breath rate (controlled by DIP 1).
LCD	The LCD box shows the ambient light sensor voltage (AMB), the back light level (BLL) and if the backlight is operative (BLF - 1 for fail, O for on).
PSU	The PSU box shows the external power supply voltage (EXT), the battery voltage (BAT), the battery charge status (CHG) and the temperature (TMP).
RAILS	The RAILS box shows the ground voltage (GRD), and the control voltages (6.5, 8.2 and 10 V).
RS232	The RS232 box shows factory set data.
PRESSURE	The PRESSURE box shows cm H ₂ O pressure value, the voltage from the pressure sensor (PSEN) and the software offset (OFFS) and gain (GAIN) values.
OXYGEN	The OXYGEN box shows the FiO ₂ %, the voltage from the oxygen sensor (OSEN) and the software offset (OFFS) and gain (GAIN) values.
ZVALVE	The ZVALVE box shows if the Z DRIVE is operative (ZDRV - 1 for fail, O for on) for the zero valve and the Z sensor (ZSEN) voltage.
DVALVE	The DVALVE box shows if the D DRIVE is operative (DDRV - 1 for fail, O for on) for the dump valve and the D sensor (DSEN) voltage.
PVALVE	The PVALVE box shows if the P DRIVE is operative (PDRV - 1 for fail, O for on) for the pressure assist valve and the P sensor (PSEN) voltage.

Chapter 5 – Operation

Gas Flow

With the oxygen and air connections connected and the power switched on, oxygen and air at 386 kPa (56 psig) flows to the blender. The air passes through a water trap with an integral filter where any moisture in the air is removed. Oxygen and air are filtered before entering a non-return valve in the blender. The blender mixes the oxygen and air in the proportion set by the position of the FiO₂ control valve. The blender supplies blended gas between 2.5 and 30 L/min.

The blender incorporates an alarm/bypass module. If a single gas supply fails or there is an imbalance between the inlet gas pressures exceeding 200 kPa (30 psig), the module directs the flow through a reed whistle to warn the Operator of the condition and at the same time connects the inlet gas at the higher pressure to the blender outlet.

The blended gas is filtered before passing through a flow control to an oxygen analyzer. The oxygen analyzer utilizes a galvanic fuel cell to measure and display the measured delivered oxygen concentration.

A vent valve on the exhaust manifold incorporates a solenoid operated pilot valve and a large orifice spool valve. The vent valve is normally held in the open position by a spring to vent high flow rates with low pressure drops so that the patient pressure is minimal. The electrically actuated pilot valve is operated by blended gas so that the vent valve continues to operate if one gas supply is lost.

Blended gas flows through an electronically operated dump valve which is normally in the closed position. If over pressurization occurs, the sensors detect the condition and the controller signals the dump valve to open, sounds an alarm buzzer and at the same time closes the vent valve to rapidly reduce the patient pressure to near zero. When the over pressure condition stops, the controller signals the vent valve to open and the dump valve to close.

The NCPAP flowmeter is set by the Operator to the required flow. The flow rate is shown on the gauge on the flowmeter. When the flowmeter control knob is turned fully clockwise, the flow of gas is turned off.

The patient pressure is shown on the touch screen and is monitored by a pressure sensor which sends the signal to the main processor. A zeroing valve automatically checks the pressure readings against atmospheric pressure to ensure accuracy of the patient pressure readings.

A mechanical pop-off valve is factory set to limit the delivered pressure to a safe level sufficient to achieve the maximum required patient pressure at the generator. Adjustment of the pop-off valve is not required by Operators.

Auxiliary Output (Optional)

Blended gas flows through a fixed flow control and non-return valve to a standard DISS fitting on the back panel to supply a maximum 15 L/min for delivery to the patient via other sources.

Inspiratory Pressure

Blended gas passes through a variable outlet flow control and through the NCPAP Pres high flowmeter. The NCPAP Pres high flowmeter is set by the Operator to the required flow. The outlet from the NCPAP Pres high flowmeter when not delivering to the patient flows through a restrictor to exhaust, allowing the flowmeter to be adjusted without delivering gas to the patient. The flow rate is shown on the gauge on the flowmeter. When the flowmeter control knob is turned fully clockwise, the flow of gas is turned off. The flow is directed to the patient via a high speed selector valve which operates when requested by the NCPAP Pres high timing.

WARNING

The NCPAP Pres high must be adjusted to zero when not required for the patient.

Triggered BiPhasic

For BiPhasic Tr, a micro controller provides reliable indications of breaths derived from the patient abdominal respiratory sensor. It sends signals to operate the NCPAP Pres high valve to provide a timed sigh.

WARNING

Under extreme conditions (minimum supply pressure and maximum gas demand, including auxiliary output) output flow rates may reduce.

Operation without Electrical Power

The IFSD can be used without electrical power. In this mode, NCPAP Pres low flow only is delivered, set by the NCPAP Pres low flowmeter and the required FiO₂ level. In this mode, visual indications and warnings are not given except for the gas failure alarm.

Electronic Functions

Sensors mounted on the valve/sensor PCB monitor pressure, flow rate and oxygen. Sense signals for each of the valves allow the micro-controller to monitor the valve's state and determine whether the valve is connected or short circuited. Current to the valve sensor PCB is limited via the fuses below a 10 VA limit to ensure safety in a possible oxygen enriched environment.

The patient trigger PCB interfaces with the main processor PCB via a 20 way head. Communication between the two PCB's is via a CAN bus. The main processor PCB also supplies +5 V power to this PCB and monitors other control signals.

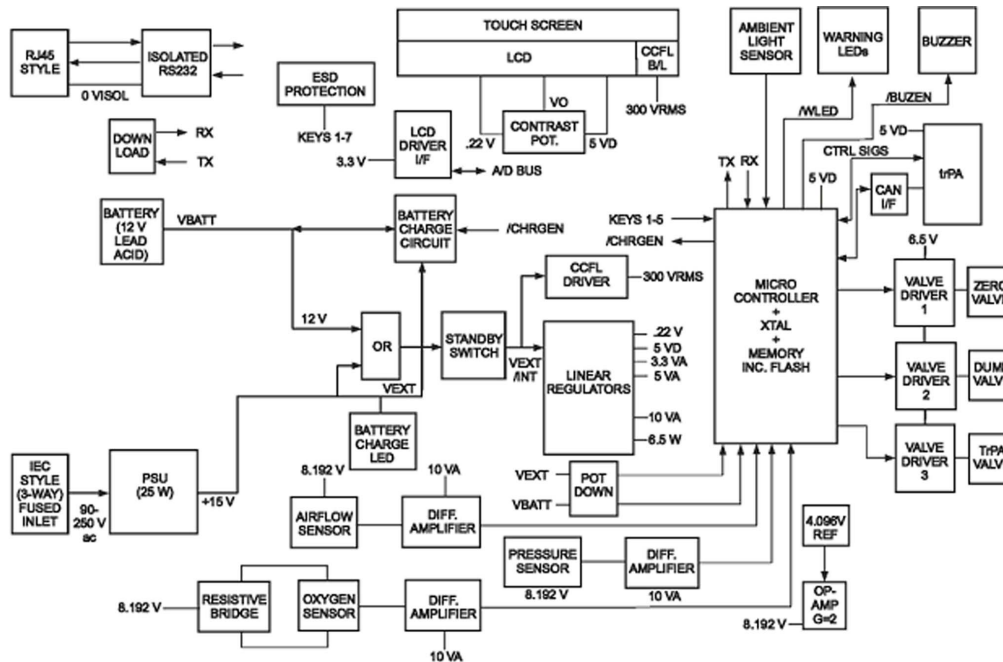

Figure 7 - IFSD Electronic Enclosure

Electrical Layout

Figure 8 shows the electrical wiring and PCB connector layout.

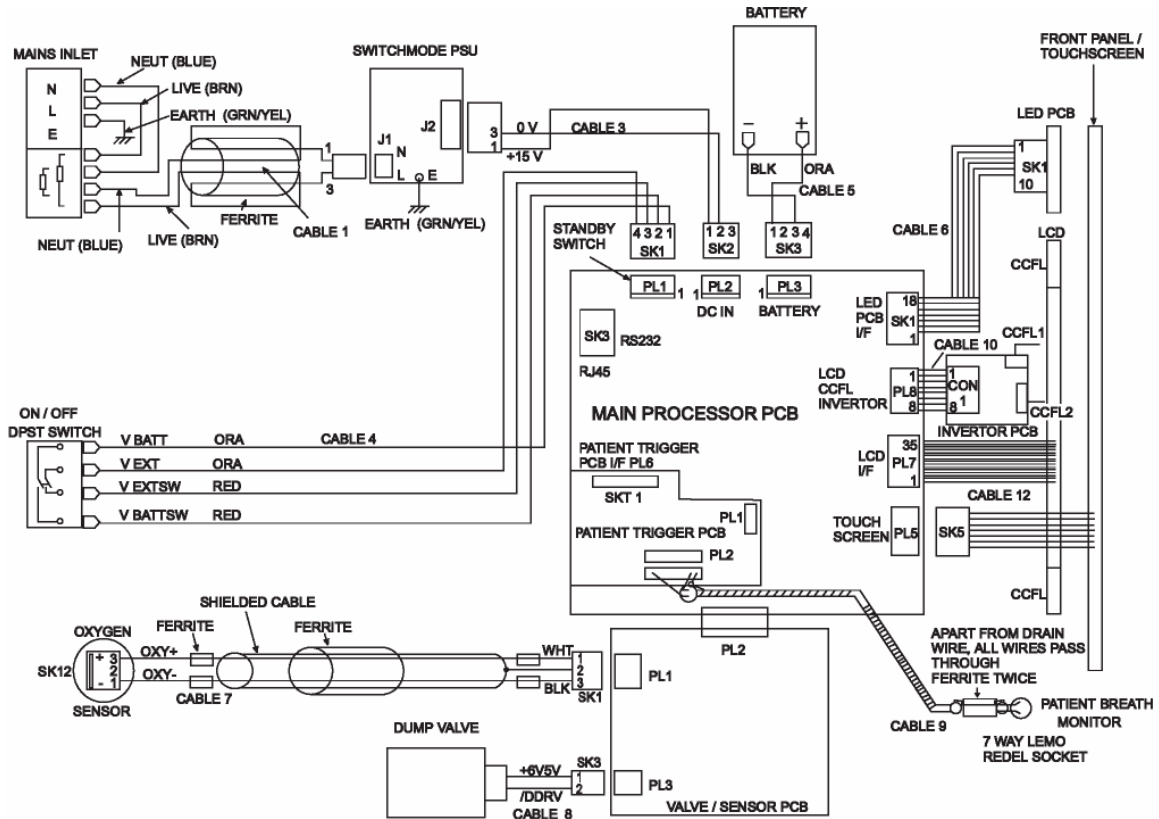

Figure 8 - IFSD Electrical Wiring Diagram

Fault Management

When a software detectable fault condition occurs, the unit still allows a basic level of treatment to the patient. Table 4 shows the fault conditions and the level of control available.

Table 4 - Faults, Available Modes and Control Functions

Alarm	Functionality	Measurements		Software Control Modes			
		FiO ₂	CmH ₂ O	NCPAP	NCPAP+ Apnea	BiPhasic + Apnea	BiPhasic Tr
Fault lockout screen shows error code(s).	Unit inoperable by software, operable in unpowered ..	X	X	X	X	X	X
Error code(s) shown on mode selection screen. Status bar mode alternates	Unit restricted to NCPAP and NCPAP+Apnea modes.	✓	✓	✓	✓	X	X
Error code(s) shown on mode selection screen. Status bar mode	Patient trigger (NCPAP+Apnea, BiPhasic+Apnea and BiPhasic Tr) modes not available.	✓	✓	✓	X	✓	X
Battery status shows discharged battery.	Unit will not operate on battery power when external power supply is removed.	✓	✓	✓	✓	✓	✓

Chapter 6 – Operation

The operating procedures below show the procedures for all models. Reference should only be made to the procedures for the model in use. Read the Warnings and Cautions at the beginning of this manual before you start the procedures.

Preparing and Connecting the Equipment

WARNING

Ensure the whistle sounds during gas connection, if not the device may be faulty and should not be used.

- 1 Connect the Medical Air and Oxygen hoses to the IFSD connections on the back panel.

Note

The gas failure alarm/bypass warning whistle sounds until the pressures balance.

WARNING

Only use the supplied AC cable to connect to the power supply.

- 2 Connect the power supply cable to a suitable power supply outlet. The green power light will come on regardless of the position of the power switch.
- 3 Connect the patient circuit to the IFSD as required. Figure 9 shows a typical configuration, the actual configuration may vary dependent on the type of ancillary equipment used and the clinical needs prescribed for the patient. For functional test purposes, the Generator nasal prongs can be occluded to simulate patient responses.
- 4 Connect the transducer module to the sensor and to the IFSD. For functional test purposes, lightly tap the abdominal respiratory sensor to simulate patient breathing.

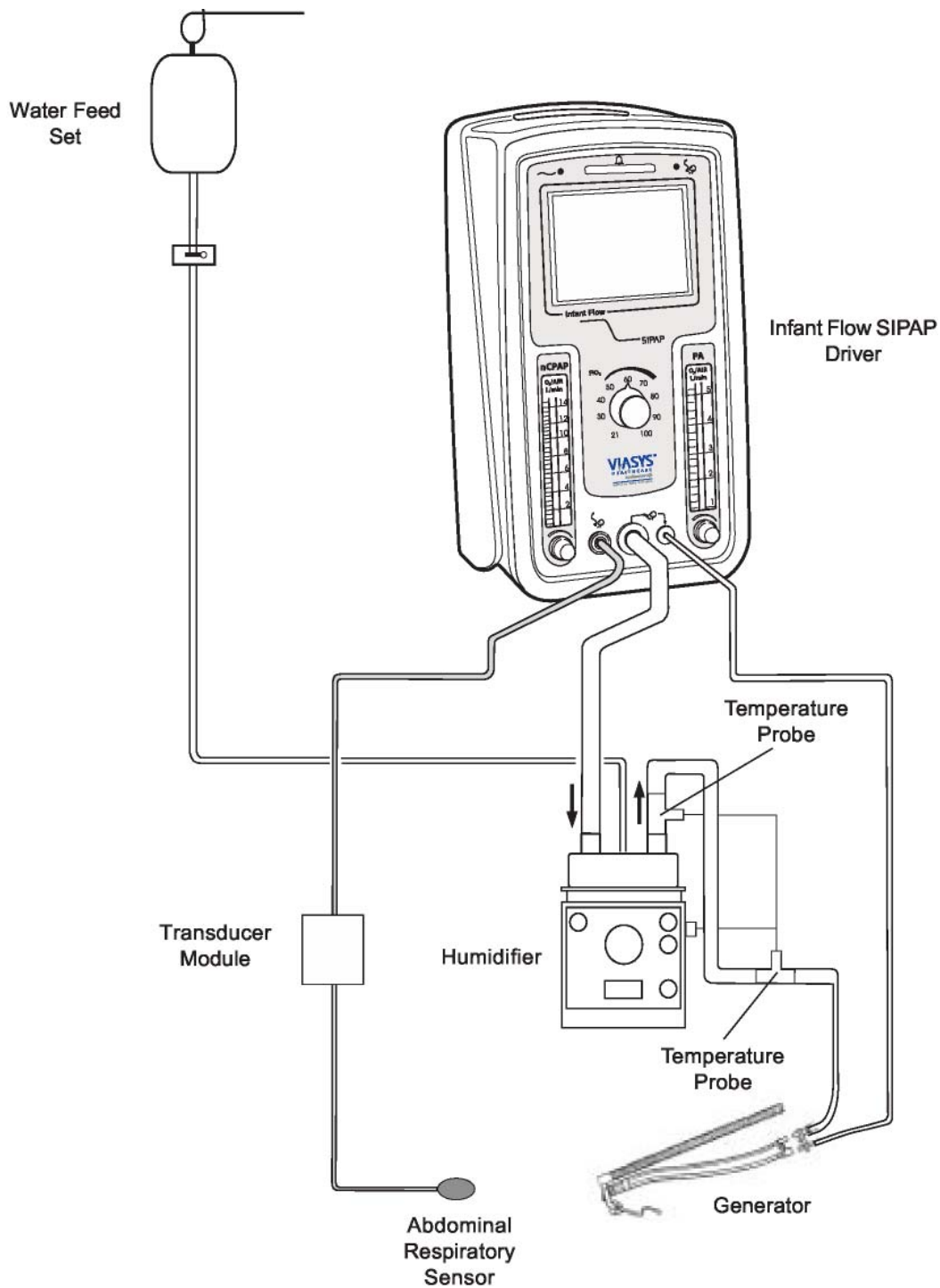

Figure 9 - Patient Connections

WARNING

Check that the water trap is empty before use and empty it frequently during use.

- 5 Make sure that the water trap is empty. If necessary, empty any water from the trap (refer to Chapter 3, Maintenance).
- 6 Gas Flow Pressure Setting

The IFSD provides a virtually constant airway pressure irrespective of patient demand or expiratory flows via the specially designed generator and nasal prongs. This is the reason for the IFSDs ability to provided superior NCPAP. The IFSD is subject to a direct relationship between controlled enriched gas flow and NCPAP pressure.

A nomogram illustrating the relationship between constant airway pressure and flow settings is shown in Figure 10. Example: 8 L/min gas flow provides 5 cm H₂O NCPAP.

Note

Individual devices have a tolerance of up to $\pm 10\%$ from that illustrated in the nomogram and in particular, at pressures below 2 cm H₂O.

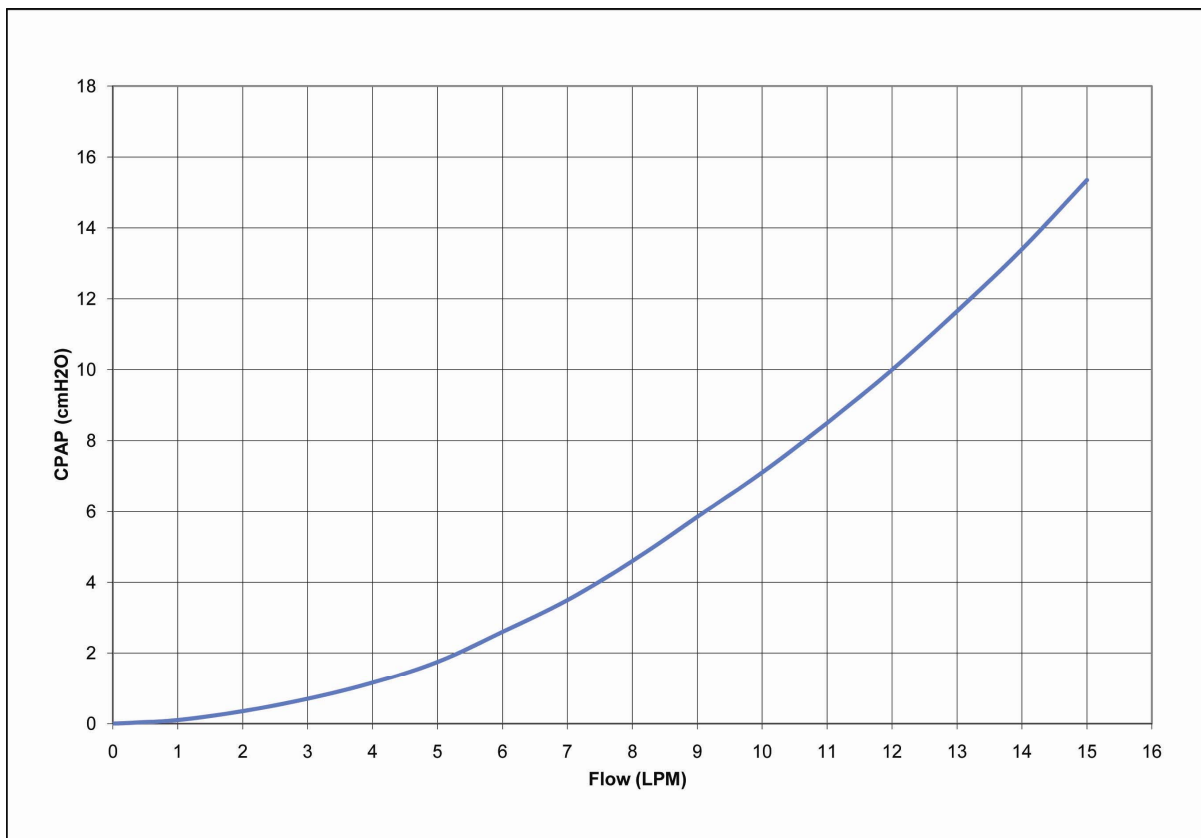



Figure 10 - Flow Pressure Nomogram

Switching On the IFSD

WARNING

Do not attach the Generator to the patient until the initial set up is complete.

Put the power switch on the back panel to the  position.

- the warning bar comes on
- the green power light remains on
- the audible alarm sounds

The unit carries out a full functional check. If the checks are not successful (program memory fault, power supply not connected or emergency battery voltage low), the screen remains black and the warning bar stays on.

If the checks are successful, the warning bar goes off and the screen changes to the Power Up Screen.

After two seconds the screen changes to the Power Up Check Screen.

During the power up checks:

- the screen image is shown in negative
- the warning bar comes on for one second
- the Apnea light comes on for one second
- the audible alarm sounds for one second
- the dump valve is tested
- the pressure is set to zero

After two seconds the screen changes to the Start Up Screen.

- the alarm limits are disabled

A flashing question mark alternating with a red cross appears under the first adjustment to be made.

To calibrate  the O₂ fuel cell, refer to the section “Calibration” on page 37.

Note

Where a mode is not applicable (e.g. Patient Trigger), the button is blank and the icons are not shown.

Alarms Test

WARNING

Prior to patient application, ensure that all User Verification testing and calibration procedures are successfully completed. User Verification testing and calibration procedures must be done off patient.

NOTE

Following each alarm verification test, ensure that control settings and alarm limits are reset as instructed before proceeding to the next test.

Alarm Test Initial Settings	
Air Supply Pressure	> 30 psig (2.1 bar)
O₂ Supply Pressure	> 30 psig (2.1 bar)
Patient Circuit	Infant Flow® Patient Circuit
Generator	Infant Flow® Generator
NCPAP / Pres Low flow meter	8 L/min (for delivery of 5 cmH ₂ O)
% O₂	30%
Pres High flow meter	3 L/min
Mode	NCPAP
For Step 9 Use the settings provided below	
Rate	30 bpm
Ti	0.3 sec
Tapnea (Non-U.S. Configuration) / T_{LBR} (U.S. Configuration)	20 sec

Perform the Alarms Test on the Infant Flow® SiPAP™ using the following steps and the initial settings provided above.

1. Make appropriate connections for air and O₂ gas supply. Connect power cord to appropriate AC outlet. Attach patient circuit, generator and patient interface (mask or prong) as shown in Figure 3. Occlude the opening to the patient.
2. Power up the driver and allow Power On Check to complete.
3. Low airway pressure alarm: From NCPAP operating mode, with alarms set, remove occlusion from opening to patient. Verify that the low airway pressure alarm activates. Restore the patient interface occlusion and press the Alarm Mute / Silence button for 3 seconds to reset the alarms.
4. High airway pressure alarm: Adjust the NCPAP / Pres Low flow meter to 11 L/min. Verify that the high airway pressure alarm activates. Return the NCPAP

/ Pres Low flow meter to 8 L/min and press the Alarm Mute / Silence button for 3 seconds to reset the alarms.

5. High %O₂ Alarm: Adjust the % O₂ control to 35%. Verify that the High %O₂ alarm activates. Return the O₂ control setting to 30%. Reset alarms by pressing the Alarm Mute / Reset button for 3 seconds.
6. Low % O₂ Alarm: Adjust the % O₂ control to 25%. Verify that the Low %O₂ alarm activates. Return the O₂ control setting to 30%. Reset alarms by pressing the Alarm Mute / Reset button for 3 seconds.
7. Loss AC Alarm: Disconnect the AC power cord from the wall outlet. Verify that the Loss AC alarm activates. Reconnect the AC power cord. Clear the alarm by pressing the Alarm Mute / Reset button.
8. High Circuit Pressure Alarm: Increase nCPAP pressure to 11.1 cmH₂O by increasing the NCPAP/PRES Low Flow meter. Verify that the High Circuit pressure alarm activates. Return NCPAP/PRES Low Flow meter to 8 LPM and press the Alarm Mute/Silence button for three seconds to reset the alarms.
9. Low Breath Rate (Apnea) Alarm: Select and confirm BiPhasic+Apnea/LBR (U.S. Configuration). Change the mandatory rate control to setting for rate to 1 bpm. Verify that the Low Breath rate alarm activates after the default interval of 20 seconds. Return the rate control to 30 bpm and clear the alarm by pressing the Alarm Mute / Reset button for 3 seconds.

Infant Flow[®] SiPAP[™] User Verification Test Checklist

Driver Serial Number: _____ Test Date: _____

TEST	PASS	FAIL
Automated Tests		
Power On Check	<input type="checkbox"/>	<input type="checkbox"/>
Manual Tests		
Two Point O ₂ Sensor Calibration	<input type="checkbox"/>	<input type="checkbox"/>
Patient Circuit Leak test	<input type="checkbox"/>	<input type="checkbox"/>
Manual Alarms Checks		
Low Airway Pressure Alarm	<input type="checkbox"/>	<input type="checkbox"/>
High Airway Pressure Alarm	<input type="checkbox"/>	<input type="checkbox"/>
High O ₂ Alarm	<input type="checkbox"/>	<input type="checkbox"/>
Low O ₂ Alarm	<input type="checkbox"/>	<input type="checkbox"/>
Loss AC Alarm	<input type="checkbox"/>	<input type="checkbox"/>
High Circuit Pressure Alarm	<input type="checkbox"/>	<input type="checkbox"/>
Low Breath Rate (Apnea) Alarm	<input type="checkbox"/>	<input type="checkbox"/>

Signature of tester: _____

Title _____

Setting Up the Equipment

The procedures show the screen set up for all modes. If a mode is not applicable to the model in use, go to the next applicable step.

Adjust the NCPAP Pres low flowmeter to indicate the required flow rate. When done, touch the flashing  button to confirm the initial setting

The button icon changes to a  and the next button starts flashing.

Set the FiO₂ and NCPAP Pres high flow as appropriate, touching the  button to confirm each time.

WARNING

Ensure that the pressure is consistent with the flow rate.

WARNING

Verify that the displayed value for delivered FiO₂ corresponds to the value set on the blender. Refer to Faults and Indications.

If an alarm is activated, the button displays a flashing cross. The alarm condition must be cleared before the setting is confirmed (refer to Table 1).

WARNING

The  indicates a connection between the transducer interface and the unit. It does not indicate correct positioning of the abdominal respiratory sensor.

Note

All triggered modes (NCPAP+Apnea, BiPhasic+Apnea, BiPhasic Tr) are automatically confirmed with a  if the patient trigger is connected.

When all of the initial settings have been confirmed (NCPAP Pres low, FiO₂, NCPAP Pres high and/or Respiratory sensor) the screen changes to the Adjust Screen.

- the alarm limits remain disabled

To set the alarm limits, touch the NCPAP button or the alarm button for three seconds. If a button is not touched within two minutes, the alarm limits will be automatically set.

Note

NCPAP+Apnea, BiPhasic+Apnea, BiPhasic Tr selection buttons are not lit if the transducer interface box is not connected to the IFSD.

When the alarm limits have been set, the screen changes to the Mode Selection Screen and defaults to the nCPAP mode.

- the alarm limits are set

Touch NCPAP, NCPAP+Apnea, BiPhasic, BiPhasic+Apnea, or BiPhasic Tr to enter the Parameter Set up Screen for each mode.

Note

When the Mode Selection screen is showing, NCPAP treatment will always be delivered.

After two minutes if the Operator has not made any inputs, the screen changes to the Locked Screen.

- the key pad is locked
- the display remains as shown for patient monitoring



Touch the  button for three seconds to unlock the key pad.

- the display returns to the Mode Selection Screen

Note

If a high priority alarm occurs, the keypad automatically unlocks.

Setting the NCPAP Parameters

For NCPAP+Apnea function the transducer interface and the abdominal respiratory sensor must be connected.

From the Mode Select Screen touch the NCPAP + Apnea  button.

The screen changes to the Parameter Set Up Screen and shows:

- the patient respiration rate (Rsp)
- the delay time for the alarm to come on Tapnea
- the Inspiratory time for a manual sigh

Use the  buttons to set the alarm delay time.

Confirm the settings by touching the flashing  button. When the settings have been accepted, the screen changes to the Locked Screen.

Touch the  button to unlock the key pad.

- the display changes to the Parameter Adjust Screen

Note

If a high priority alarm occurs, the key pad automatically unlocks.

To return to the Mode Selection Screen, touch the  button.

Setting the BiPhasic Parameters

For BiPhasic+Apnea function the transducer interface and the abdominal respiratory sensor must be connected.

From the Mode Select Screen touch the BiPhasic  button.

The screen changes to the Parameter Set Up Screen and shows:



- the NCPAP Pres high inspiration time (Ti)
- the NCPAP Pres high respiration rate (R)
- the Inspiration/Expiration ratio (I/E)

Note

If a transducer interface is connected to the unit,  is displayed and BiPhasic + Apnea monitoring mode is enabled. In addition to the above parameters, the screen shows:

- the detected breath bar graph
- the detected breath rate (Rsp)
- the delay time for the alarm to come on (Tapnea)

Push the individual buttons to select between the parameters Ti, Rate, and Tapnea.

Use the   buttons to set the parameter for Ti, Rate, and Tapnea.

Note

The I/E rate changes accordingly.

Confirm the BiPhasic settings by touching the flashing BiPhasic or BiPhasic + Apnea button.

When the settings have been accepted, the screen changes to the locked screen and treatment starts.

To adjust the parameters, touch the  button.

The screen changes to the BiPhasic or BiPhasic + Apnea Adjust Screen.

Parameters Ti and Rate can now be adjusted.

Note

The I/E rate changes accordingly.

To return to the Mode Selection Screen, touch the  button.

Note

The button is shown with a pink background if an alarm condition occurs. If this occurs, the button cannot be operated until the alarm condition has been cleared or silenced using the alarm button.

After two minutes if the Operator has not made any inputs, the screen changes to the Locked Screen.

- the key pad is locked
- the display remains as shown for patient monitoring

Touch the  button to unlock the keypad.

- the display returns to the BiPhasic or BiPhasic + Apnea Adjust Screen

Note

If a high priority alarm occurs, the keypad automatically unlocks.

Setting the Triggered BiPhasic Parameters

From the Mode Select Screen touch the BiPhasic Tr  button.



Note

The transducer interface must be connected to enter this mode.

The screen changes to the Parameter Set Up Screen and shows:

- the patient's respiration rate (Rsp)
- the NCPAP Pres high inspiration time (Ti)
- the NCPAP Pres high backup respiration rate (Rb)
- the delay time for the apnea alarm to come on (Tapnea)

Press each individual button to select between the parameters Ti, Rb and Tapnea.

Use the   buttons to set the parameter for Ti, Rb and Tapnea.

Confirm the BiPhasic Tr settings by touching the flashing BiPhasic Tr button.

When the settings have been accepted, the screen changes to the locked screen and treatment starts.

To adjust the parameters, touch the  button.

The screen changes to the BIPHASIC TR Adjust Screen.

Parameters Ti, Rb and Tapnea can now be adjusted.

To return to the Mode Selection Screen, touch the  button.

Note

The  button is blank if an alarm condition occurs. If this occurs, the button cannot be operated until the alarm condition has been cleared or silenced using the alarm button.

After two minutes if the Operator has not made any inputs, the screen changes to the Locked Screen.

- the key pad is locked
- the display remains as shown for patient monitoring

Touch the  button to unlock the key pad.

- the display returns to the BiPhasic Tr Adjust Screen

Note

If a high priority alarm occurs, the key pad automatically unlocks.

Calibration

WARNING

Calibration must only be done when the unit is not connected to the patient.

From the Start Up Screen touch the  button.

The screen changes to the Calibration Screen.

- the alarm limits are disabled

Turn the FiO₂ control to 21 and confirm by touching the flashing  button.

Turn the FiO₂ control to 100 and confirm by touching the flashing  button.

Touch the  button.

The screen returns to the Start Up Screen .

Note

If the calibration procedure fails, a red  is shown in the applicable button. Re-calibrate and if necessary, replace the O₂ fuel cell.

Giving a Manual Timed Sigh

In the Mode Select or Adjust screens of NCPAP+Apnea, BiPhasic+Apnea or BiPhasic

Tr - touch the  button to give the patient a manual timed sigh.

Operation Without Electrical Power

The IFSD can be used without mains or battery power. To use the IFSD in this mode, set the required NCPAP flow on the NCPAP Pres low flowmeter and the required FiO₂ level. All audible and visual indications and warnings are not given except for the gas failure alarm/bypass which will operate until pressures are balanced.

Fault Indications

Refer to Table 1 (all models) and Table 2 (BiPhasic and BiPhasic Tr models only) for the fault indications for specific faults and the procedures for resetting or canceling.

Discharged Battery

When the battery voltage is too low to power the circuits, the screen changes to the Power Down Screen.

- all functions and controllable inputs are disabled
- the controller waits for the power source to be connected
- when external power is restored, the screen changes to the Power Up Screen
- the screen goes blank when the battery power is too low to power the Power Down Screen

Fault Lockout

If a fault occurs which is detectable by the software and prevents the unit from operating correctly, the screen changes to the Fault Lockout Screen.

- all functions and controllable inputs are disabled but the unit can still be used without electrical power
- the related fault code numbers are shown on the screen
- the alarm bar comes on and the predominant fault code number is shown in the status bar

If an error code is shown, refer to the Service Manual or contact your Service Engineer to rectify the faults.

Over Pressure Indications

If an over pressure occurs, the software opens the dump valve to release the pressure.

- the upper pressure limit is shown in red
- the pressure display flashes
- when the pressure drops below the lower limit, the lower limit is shown in red and the pressure flashes alternately between the limits

Rectify the fault by adjustment of the high pressure and touch the warning button for three seconds to reset.

Table 5 - Faults and Indications

Alarm	Method of Setting	Indications and Actions	Method of Resetting or Canceling
Minimum oxygen concentration ($\leq 18 \text{ FiO}_2$).	Always active when power is on.	Intermittent high level Audible Alarm. Warning Bar flashes. FiO_2 display flashes. Digital O_2 alarm low limit is highlighted. Alarm Button flashes.	Restore FiO_2 level to above the low limit then push Alarm Button for three seconds.
Over pressure (Patient pressure $> 11 \text{ cmH}_2\text{O}$ when in NCPAP mode).	Always active when power is on.	Intermittent high level Audible Alarm. Warning Bar flashes. Pressure display flashes. Digital high-pressure alarm limit is highlighted. Alarm Button flashes. Dump valve actuated for three seconds to stop flow to patient and repeated until flow returns to normal.	Reduce pressure to below the high pressure limit then push the Alarm Button for three seconds.
High oxygen concentration ($\geq 5 \text{ FiO}_2$ above set point at time alarm is set for 15 seconds, or $\geq 104 \text{ FiO}_2$ for ≥ 15 seconds).	Set automatically on entering NCPAP mode for the first time after start up or by pushing the Alarm Button for three seconds at any time.	Intermittent high level Audible Alarm. Warning Bar flashes. O_2 digital display flashes. Digital O_2 alarm high limit is highlighted. Alarm Button flashes.	Push the Alarm Button once to stop the Audible Alarm for 30 seconds (Alarm Button flashes, digital O_2 alarm high limit stays highlighted, Warning Bar still flashes). Push the Alarm Button for three seconds to reset the limit (alarms clear).

Alarm	Method of Setting	Indications and Actions	Method of Resetting or Canceling
<p>Low oxygen concentration (≤ 5 FiO₂ below set point at time alarm is set for 15 seconds, or ≤ 20 FiO₂ for ≥ 15 seconds).</p>	<p>Set automatically on entering NCPAP mode for the first time after start up or by pushing the alarm button for three seconds at any time.</p>	<p>Intermittent high level Audible Alarm. Warning Bar flashes. O₂ digital display flashes. Digital O₂ alarm low limit is highlighted. Alarm Button flashes.</p>	<p>Push the Alarm Button once to stop the Audible Alarm for 30 seconds (Alarm Button flashes, digital O₂ alarm low limit stays highlighted, Warning Bar still flashes). Push the Alarm Button for three seconds to reset the limit (alarms clear).</p>
<p>High NCPAP pressure (≥ 3 cmH₂O above set point at time alarm is set for 15 seconds).</p>	<p>Set automatically on entering NCPAP mode for the first time after start up or by pushing the alarm button for three seconds at any time.</p>	<p>Intermittent high level Audible Alarm. Warning Bar flashes. Pressure display flashes. Digital pressure high limit is highlighted. Alarm Button flashes.</p>	<p>Push the Alarm Button once to stop the audible alarm for 30 seconds (Alarm Button flashes, digital pressure high limit stays highlighted, Warning Bar still flashes). Push the Alarm Button for three seconds to reset the limit (alarms clear).</p>
<p>Low pressure (≤ 2 cmH₂O below set point for 15 seconds) or ≤ 1 cmH₂O at any time).</p>	<p>Set automatically on entering NCPAP mode for the first time after start up or by pushing the alarm button for three seconds at any time.</p>	<p>Intermittent high level Audible Alarm. Warning Bar flashes. Pressure display flashes. Digital pressure low limit is highlighted. Alarm Button flashes.</p>	<p>Push the Alarm Button once to stop the Audible Alarm for 30 seconds (Alarm Button flashes, digital pressure low limit stays highlighted, Warning Bar still flashes). Push the Alarm Button for three seconds to reset the limit (alarms clear).</p>

Alarm	Method of Setting	Indications and Actions	Method of Resetting or Canceling
Over pressure (Patient pressure > 11 cmH ₂ O when in BiPhasic or BiPhasic Tr mode).	Always active when power is on.	Intermittent high level Audible Alarm. Warning Bar flashes. O ₂ digital display flashes. Digital O ₂ alarm low limit is highlighted. Alarm Button flashes.	Reduce pressure to below the high pressure limit then push the Alarm Button for three seconds.
High BiPhasic/ BiPhasic Tr pressure (MAP ≥ 3 cmH ₂ O above set point at time alarm is set for 15 seconds).	Set automatically on entering NCPAP mode for the first time after start up or by pushing the alarm button for three seconds at any time.	Intermittent high level Audible Alarm. Warning Bar flashes. High MAP pressure display flashes. Digital high MAP pressure limit is highlighted. Alarm Button flashes.	Push the Alarm Button once to stop the Audible Alarm for 30 seconds (Alarm Button flashes, digital high MAP pressure limit stays highlighted, Warning Bar still flashes). Push the Alarm Button for three seconds to reset the limit (alarms clear).
Low battery charge (≤ 40%).	Automatic	Battery status indicator changes from gray to red.	Connect external power.
Low battery voltage (≤ 10 V for 5 seconds).	Automatically constantly monitored with the power switch in the on position with no external power connected.	Intermittent medium level Audible Alarm. Warning Bar flashes intermittently. Battery status indicator flashes. Unit starts a controlled shut down at a set limit.	Push the Alarm Button once to stop the Audible Alarm for three minutes (Alarm Button flashes, battery status indicator stays flashing). Connect external power (alarms clear). Visual alarms remain until battery charge state is above low

Alarm	Method of Setting	Indications and Actions	Method of Resetting or Canceling
Battery fault (Battery disconnected or failing to take or hold charge).	Automatic	Intermittent high level Audible Alarm. Warning Bar flashes intermittently. Battery status indicator flashes. Screen displays flashing fault code (E number)	Cannot be reset. Push the Alarm Button once to stop the Audible Alarm for 60 seconds. Refer to Service Engineer.
External power disconnected.	Automatic	Intermittent high level Audible Alarm. Warning Bar flashes intermittently. Battery status indicator and power indicator alternately flash.	Push the Alarm Button once to stop the audible alarm. (The Warning Bar stops flashing and the battery status indicator is displayed.) Reconnect the external power.
Software fault	Automatic	Intermittent high level Audible Alarm. Warning Bar flashes intermittently. Screen displays flashing fault code (E number).	Cannot be reset. Refer to Service Engineer.
Software not running with unit connected to power	Automatic	Constant Audible Alarm. Warning Bar on. Screen displays flashing fault code (E number).	Cannot be reset. Refer to Service Engineer.
Blender whistle	Water trap blocked, full or leaking; filters blocked; loss of wall pressure; imbalance of wall gas supply.	Audible Alarm.	Refer to Service Engineer.
Oxygen cell calibration error.	Automatic monitoring (oxygen cell incorrectly calibrated, damaged or depleted).	Difference between displayed and set value.	Calibrate or replace oxygen cell. Refer to Service Manual.

Alarm	Method of Setting	Indications and Actions	Method of Resetting or Canceling
Flowmeter fault.	Flowmeter fault	No flow indications or flow cannot be adjusted.	Refer to Service Engineer.
Electrical fault.	Electrical fault	External power light does not match screen icon.	Refer to Service Engineer.
Low breath rate (Rr = 0 for \geq breath rate timeout as determined by patient trigger module).	Set automatically on entering BiPhasic Tr, NCPAP + Apnea or BiPhasic +Apnea modes if patient trigger is installed and selected.	<p>Intermittent high level Audible Alarm.</p> <p>Warning Bar flashes.</p> <p>Breath rate digital display flashes.</p> <p>Breath rate icon flashes.</p> <p>In BiPhasic models with monitored NCPAP + Apnea, a single sigh is given.</p> <p>In BiPhasic Tr Mode backup sighs at the set rate are given.</p> <p>Alarm Button flashes.</p> <p>The timer is reset and the applicable sigh function is repeated until breathing restoration is detected or the Operator intervenes.</p>	<p>Push the Alarm Button once to stop the Audible Alarm for 30 seconds (Alarm Button flashes, breath rate icon and digital display still flashes, Warning Bar still flashes, in BiPhasic Tr Mode backup sighs at the set rate continue).</p> <p>Restore patient breathing.</p> <p>If breath detection is restored before the next breath rate timeout period has elapsed, the alarm condition is automatically cleared.</p>
BiPhasic/BiPhasic Tr mode fails to operate as set.	Automatic monitoring	<p>Intermittent high level Audible Alarm.</p> <p>Warning Bar flashes intermittently.</p> <p>NCPAP Pres high on time display flashes.</p> <p>Screen displays flashing fault code (E number).</p>	Cannot be silenced Revert to NCPAP mode or refer to Service Engineer.

Diagnostics

Diagnostic mode is accessed by enabling DIP switch 6 and exited by disabling it.

Enable DIP switch 6 during Start Up, Adjust or Mode Selection.

The screen changes to the Diagnostics Menu Screen (for a description of the displayed information, refer to pages 17-18):

- the alarm limits are disabled
- low level calibration procedure for pressure and oxygen sensors are available via the key pad
- test procedures for valves and user interface are available via the key pad
- the error log is accessible via the key pad

Select  to carry out a pressure calibration

The diagnostic main screen stays the same and the key pad layout changes. With nothing attached to the pressure line inlet port, touch the first key to calibrate at 0 cm H₂O. Connect pressure gauge to the inlet port and adjust the nCPAP Flowmeter until pressure reads 10 cm H₂O +/- 0.2 cm H₂O, and touch the second key to calibrate at 10 cm H₂O.

To return to the Diagnostics Menu Screen, touch the  button.

Select  to carry out an oxygen calibration

The diagnostic main screen stays the same and the key pad layout changes. Set the blender knob at 21% and touch the first key to calibrate at 21 %. Set the blender knob at 100% O₂ and touch the second key to calibrate at 100 % O₂.

To return to the Diagnostics Menu Screen, touch the  button.

Select  to enter a security code.

In order to upgrade features on the unit, a security code must be obtained from Cardinal Health Technical Support (see Figure 11). After the code is entered, the customer's unit can be upgraded to different feature sets as laid out by Marketing.





Figure 11 – Security Screen

To return to the Diagnostics Menu Screen, touch the  button.

Select  to carry out a valve test

The diagnostic main screen stays the same and the key pad layout changes. Touch the first key to test the zero valve, the second key to test the dump valve and the third key to test the PA valve.

To return to the Diagnostics Menu Screen, touch the  button.

Select  to carry out a user interface test

The diagnostic main screen stays the same and the key pad layout changes. Touch the first key to test the battery, the second key to test the audible alarm and the third to test the respiratory indicator.

To return to the Diagnostics Menu Screen, touch the  button.

Touch the  button to show the Error Log Screen

The screen changes to the Error Log Screen and shows a list of error code numbers. The error code is:

- shown normal if it has occurred since the last reset
- shown grayed if it is inactive since the last reset
- flashing if the error is active since power up or last cleared

To mute flashing errors, the  button.

Refer to Table 6 for the details of error codes and corrective action.

When the corrective action has been taken, to clear all faults, press the  button.

Table 6 - Error Codes

Error Code	Fault Condition	Consequence	Software Response	Corrective Action
-	Program memory checksum error.	Unusable – Software corrupt, execution inhibited.	Hardware held in permanent reset condition with Warning Bar on.	Reload software.
-	Battery too discharged (<6.5 V) to operate LCD, analogue and valve driver circuits (no external power).	Unusable - no user interface display.	Hardware held in reset condition with Warning Bar (status LED off) on until external power applied.	Plug in external power.
-	Battery too discharged (<10 V) to operate analogue and valve driver circuits but sufficient for LCD driver (no external power).	Unusable – sensor readings invalid.	User lockout 'Plug in external power' prompt	Plug in external power.
E10	Non-volatile memory fault.	Unusable - unable to retrieve/set unit configuration and calibration data.	User lockout 'Error number' prompt.	Replace main control PCB.
E11	Calibration data lost.	Unusable – sensor readings invalid.	User lockout 'Error number' prompt.	Put the unit into diagnostics mode (DIP6 ON) and recalibrate O ₂ and pressure sensors.
E12	Configuration DIP settings and/or PT PRESENT different to non-volatile configuration record.	Unusable – possible incomplete unit set up performed.	User lockout 'Error number' prompt.	Ensure that all the DIP switch settings are correct and the patient trigger board/cable are correctly attached (if required). Put the unit into diagnostics mode, clear the E12 error, then return to normal mode.

Error Code	Fault Condition	Consequence	Software Response	Corrective Action
E20	Charged battery voltage too low (<11 V) when under test load.	No backup – battery capacity low.	Battery fault icon flashes and 'Error number' alarm prompt.	Replace battery or charger.
E21	External supply voltage too low (<14 V) to charge battery (battery flat).	No backup – battery will not charge.	Battery low alarm continues even when external power applied. 'Error number' alarm prompt.	Replace the PSU module.
E22	Analog supply rails out of limits.	Unusable - unreliable sensor readings.	User lockout 'Error number' prompt.	Replace the main control PCB and re-calibrate O ₂ and pressure sensors.
E23	Valve driver supply rails out of limits.	Unusable - unreliable valve operations.	User lockout 'Error number' prompt.	Replace the main control PCB and re-calibrate O ₂ and pressure sensors.
E24	Hardware safe-start watchdog disabled.	Unusable – valve disabled.	User lockout 'Error number' prompt.	Power cycle unit. If fault still occurs, replace the main control PCB and re-calibrate O ₂ and pressure sensors.
E30	Pressure sensor fault (ADC hits rail).	Unusable – pressure sensor readings invalid.	User lockout 'Error number' prompt.	Replace the pneumatics PCB and re-calibrate O ₂ and pressure sensors.
E31	Zero valve not connected (via sense).	Unusable – pressure sensor readings unreliable.	User lockout 'Error number' prompt.	Replace the pneumatics PCB and re-calibrate O ₂ and pressure sensors.

Error Code	Fault Condition	Consequence	Software Response	Corrective Action
E32	Zero valve activation fault (via sense).	Unusable – pressure sensor readings unreliable.	User lockout 'Error number' prompt.	Replace the pneumatics PCB and re-calibrate O ₂ and pressure sensors.
E33	Unable to auto zero pressure sensor.	Unusable – pressure sensor readings unreliable.	User lockout 'Error number' prompt.	Replace the pneumatics PCB and re-calibrate O ₂ and pressure sensors.
E41	Dump valve not connected (via sense).	Restricted - no over pressure protection.	Restricted mode 'Error number' alarm prompt.	Replace the pneumatics PCB and re-calibrate O ₂ and pressure sensors.
E42	Dump valve activation fault (via sense).	Restricted - no over pressure protection.	Restricted mode 'Error number' alarm prompt.	Replace the pneumatics PCB and re-calibrate O ₂ and pressure sensors.
E50	Oxygen sensor fault (ADC hits rail).	Unusable – oxygen sensor readings invalid.	User lockout "Error number" prompt.	Replace the pneumatics PCB and re-calibrate O ₂ and pressure sensors / circuits.
E51	Oxygen sensor cannot be calibrated by user (bad offset or high gain).	Unusable – possible fuel cell, electronic, blender or gas supply fault.	User lockout "Error number" prompt.	Check the Error Log screen in diagnostics mode. If an E52 error also occurs, replace the fuel cell and re-calibrate the O ₂ sensor- otherwise check the blender ,gas supplies, or circuits.

Error Code	Fault Condition	Consequence	Software Response	Corrective Action
E52	Oxygen sensor calibrates but the fuel cell is worn out (low gain).	Unusable – oxygen sensor readings unreliable.	User lockout “Error number” prompt.	Replace the O ₂ fuel cell and re-calibrate the O ₂ sensor.
E53	Oxygen sensor too noisy to calibrate (calibration timeout).	Unusable – oxygen sensor readings unreliable.	User lockout “Error number” prompt.	Replace the O ₂ fuel cell and re-calibrate the O ₂ sensor or circuits.
E54	Oxygen calibration suspect (oxygen value has been measured as outside range 18 – 104%)	Oxygen sensor readings unreliable	“E##” alarm, non-mutable, pending oxygen re-calibration	Recalibrate O ₂ sensor. If this fails replace the O ₂ cell and re-calibrate.
E61	NCPAP Pres high valve not connected (via sense).	Restricted - BiPhasic/BiPhasic unusable.	Restricted mode. ‘Error number’ alarm prompt.	Replace the pneumatics PCB and re-calibrate the O ₂ and pressure sensor.
E62	NCPAP Pres high valve activation fault (via sense).	Restricted - BiPhasic/BiPhasic Tr unusable.	Restricted mode. ‘Error number’ alarm prompt.	Replace the pneumatics PCB and re-calibrate the O ₂ and pressure sensor.
E70	PT module fault (PTRDY or CAN bus failure).	Untriggerable - Apnea and PT unusable.	Reduced functionality ‘Error number’ alarm prompt.	Check the Patient Trigger interface module/cables are correctly connected.
E71	No breath signal from PT module although CAN data does not report Apnea.	Untriggerable - Patient may be in Apnea but PT module may be dysfunctional.	Reduced functionality ‘Error number’ alarm prompt.	Replace the Patient Trigger board/cable.

Error Code	Fault Condition	Consequence	Software Response	Corrective Action
E72	No trigger signal from PT module in BiPhasic Tr mode.	Untriggerable – No BiPhasic Tr treatment given to patient.	Reduced functionality 'Error number' alarm prompt.	Replace the Patient Trigger board/cable.
E90*	Spurious software interrupt, XTAL fails, stack overflow/ underflow, CPU Class B exception.	Spurious – software interrupted and restarts (possibly during treatment).	Hardware reinitialized (disabled) with alarm bar on and audible alarm sounding to identify root cause.	Replace the main control PCB and re-calibrate O ₂ and pressure sensors.
E90	Abnormal hardware, software or watchdog reset.	Spurious – software restarts possibly during treatment.	Software restarts 'Error number' alarm prompt.	Replace the main control PCB and re-calibrate O ₂ and pressure sensors.
E91	Internal software error detected.	Unusable – software unreliable.	User lockout 'Error number' prompt.	Replace the main control PCB and re-calibrate O ₂ and pressure sensors.
E99	Unknown error detected.	Unusable – software unreliable.	User lockout 'Error number' prompt.	Replace the main control PCB and re-calibrate O ₂ and pressure sensors.

* - Generated as a consequence of the fault.

Chapter 7 – Maintenance

Cleaning

CAUTION

Do not immerse any part of the IFSD in water or sterilize it with gas or steam.

- 1 Clean the exterior surfaces of the IFSD and the transducer interface with a mild soap or liquid disinfectant solution. Do not use cleaning agents that contain abrasives.
- 2 Make sure that cleaning agents do not enter the unit through patient connection ports.

Maintenance

WARNING

Oxygen vigorously accelerates combustion. To avoid explosion hazard, do not use any instrument or other equipment that may have been exposed to oil or grease contamination.

General

- 1 Examine the exterior of the case for damage and dirt. If necessary clean the unit.
- 2 Check the water trap on the back panel. If water is visible in the water trap, push the button on the bottom of the water trap to release the water.
- 3 Technical Assistance can be obtained from the offices listed at the beginning of this manual.
- 4 Store the unit in a clean dry location. Make sure that the connections and ports are suitably blanked to prevent the ingress of dirt, moisture and foreign objects. If the unit is not being used for a long period of time, remove the battery.
- 5 Dispose of scrap units in accordance with the local regulations

Removal and Fitting of Parts – General

- 1 Only parts approved by Cardinal Health may be used in this unit.
- 2 Remove all attached patient connections before removal of parts. Disconnect the unit from the power supply.
- 3 Place the unit on a stable, clean work surface before removal of parts.
- 4 Numbers in parenthesis in the Removal/Fitting procedures are the item numbers on the associated figure.

Maintenance Frequencies

Table 7 shows the recommended frequencies for replacement of components.

Table 7 - Maintenance Frequencies

Component	Replacement Frequency
Battery	Annually
Oxygen Filter	Annually
Fuel Cell Filter/Restrictor	Annually
Fuel Cell	Annually
Blender (Check Valves and Filter)	Annually
Water Trap Filter	Annually
Pilot Drive Check Valves	Annually
Case Bleed Filtered Restrictor	Annually
Blender Alarm and Bypass Components (by replacement of blender or Blender Overhaul Kit)	Every Two Years
Solenoid Valve (by replacement of Valve/Sensor PCB)	Every Five Years

Removal and Fitting of Case

Refer to Figure 12.

Removal

- 1 Remove the ten screws (1) on the rear panel.
- 2 Pull off the case (2).

Fitting

- 1 Install the case (2) over the main frame, making sure that all wires and pipes are secure and cannot be trapped by the case.
- 2 Install the ten screws (1) on the rear panel and tighten.
3. Carry out an Oxygen Leak check (see Appendix A on page 69) and functional check of the IFSD.

Note: An Oxygen Leak test must be done after every service that requires removal of the case to ensure no buildup of oxygen is present within the case.

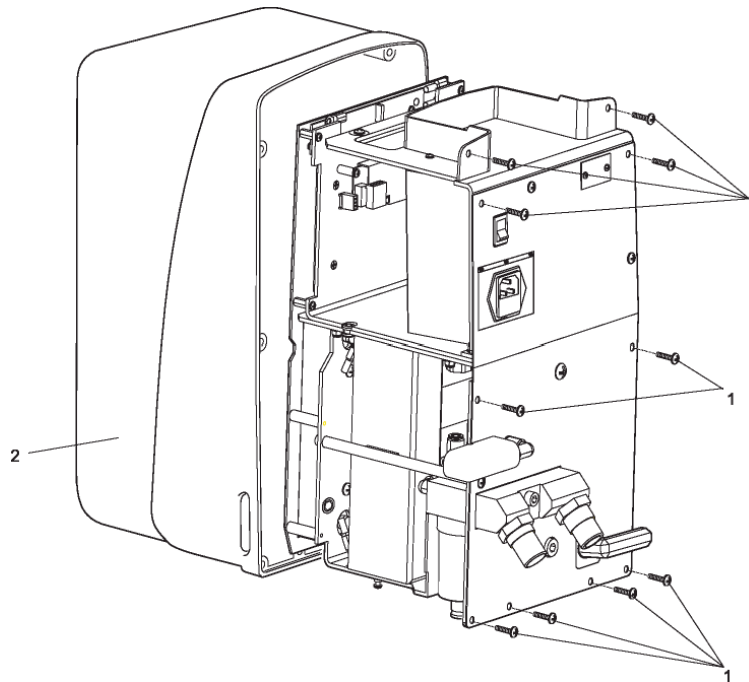

Figure 12 - Case Removal/Fitting

Removal and Fitting of Battery

Refer to Figure 13.

Removal

- 1 Remove the case.
- 2 Disconnect the battery lead connector SK3 (1) (cable 5) from the plug PL3 on the Main Processor PCB. Remove the screw (2) on the rear panel and remove the spacer (3). Note position of cable tie securing battery, then cut and remove cable tie.
- 3 Pull the battery (4) complete with lead from the compartment.

Note

The battery is held in position in the compartment by a tab on the frame and secured by cable tie P/N 461964.

- 4 Feed the battery lead through the frame, pull the grommet (6) from the recessed hole in the frame and remove the battery.

Note

Exhausted batteries and oxygen fuel cells both contain lead and must be disposed of according to local regulations.

Fitting

- 1 Feed the battery lead through the frame to plug PL3 on the Main Processor PCB.
- 2 Slide the battery into the compartment against the tab (5) and position the grommet (6) in the recessed hole in the frame.
- 3 Install the spacer (3) and secure in position with the screw (2). Tighten the screw (2).
- 4 Connect the battery lead connector SK3 (1) to the plug PL3 on the Main Processor PCB.
- 5 Install new cable tie securing the battery against the metal tab.
- 6 Refit the case.

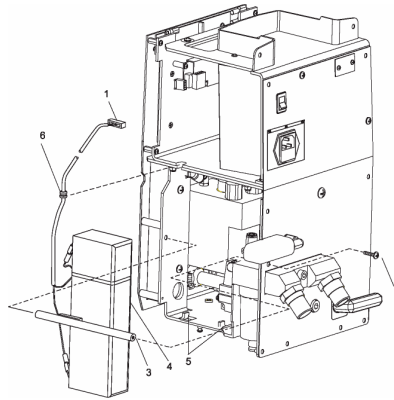

Figure 13 - Battery Removal/Fitting

Removal and Fitting of Oxygen Filter

Note

This procedure can be done without removing the case.

Refer to Figure 14.

Removal

- 1 Remove the banjo screw (1) on the end of the air/oxygen mounting block (2).
- 2 Remove the filter (3).
- 3 Remove and discard the O-ring (4).

Fitting

- 1 Install a new O-ring (4) on the banjo screw (1).
- 2 Install a new filter (3) in the air/oxygen mounting block and install the banjo screw (1).
- 3 Tighten the banjo screw (1).

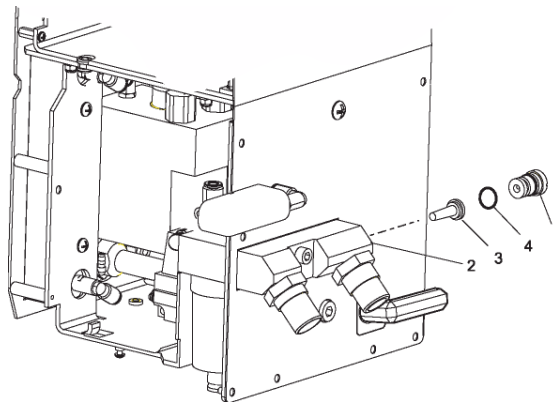

Figure 14 - Oxygen Filter Removal/Fitting

Removal and Fitting of Fuel Cell Filter/Restrictor

Refer to Figure 15.

Removal

- 1 Remove the case .
- 2 Remove the oxygen filter screw (1) from the flow mixer block (2). Remove the filter/restrictor (3). Remove and discard the O-ring (4) and the O-ring (5) from the oxygen filter screw (1).

Fitting

- 1 Install a new O-ring (5) on the oxygen filter screw (1). Install a new O-ring (4) and the filter/ restrictor (3) into the flow mixer block (2). Install the oxygen filter screw (1) and tighten.
- 2 Refit the Case.
- 3 Carry out an Oxygen Leak check (see Appendix A on page 69) and functional check of the IFSD and calibrate the fuel cell.

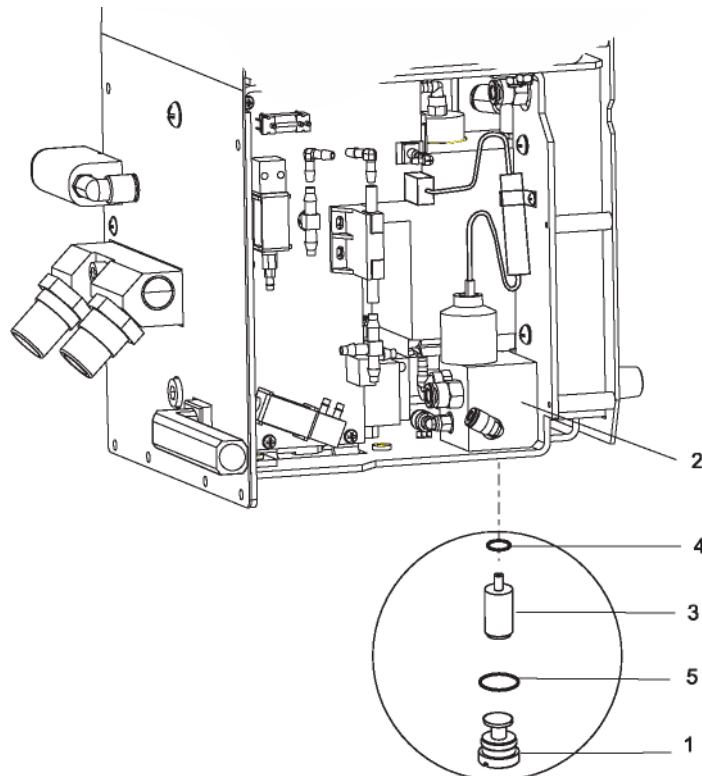

Figure 15 - Oxygen Filter Restrictor Removal/Fitting

Removal and Fitting of the Fuel Cell

Refer to Figure 16.

Removal

- 1 Remove the case.
- 2 Disconnect the connector SK12 (1) from the top of the fuel cell.
- 3 If necessary, remove the screw (2) securing the C clip (3) and release the C clip securing the cable (cable 7) and the ferrite.
- 4 Unscrew the fuel cell (4) from the flow mixer block (5).

Note

The fuel cell is installed finger tight, but it may be necessary to use a suitable wrench on the flats at the top of the fuel cell to remove it. The leak compensation pipe (6) can also be disconnected from the elbow to gain access.

- 5 Discard the fuel cell (4) and attached O-ring.

Note

Exhausted batteries and oxygen fuel cells both contain lead and must be disposed of according to local regulations.

Fitting

- 1 Check the expiration date of the new fuel cell. Remove the fuel cell from the sealed package and check that the fuel cell has an O-ring installed above the threads.
- 2 Screw the fuel cell (4) into the flow mixer block (5) and tighten finger tight.
- 3 If removed, secure the cable (cable 7) and the ferrite with C clip (3) and the screw (2).
- 4 Connect the connector SK12 (1) to the fuel cell.
- 5 Refit the case.
- 6 Carry out an Oxygen Leak check (see Appendix A on page 69) and functional check of the IFSD and calibrate the fuel cell.

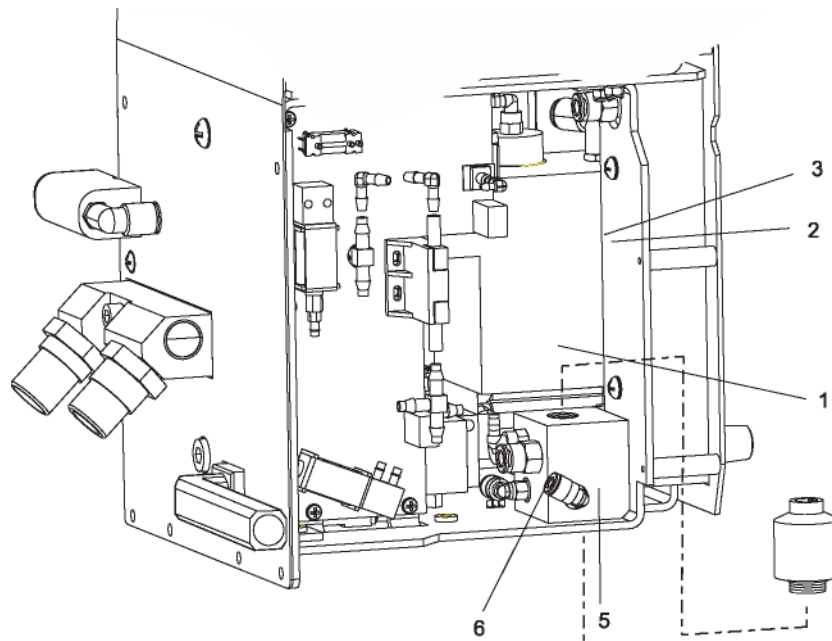

Figure 16 - Fuel Cell Removal/Fitting

Removal and Fitting of Blender and Components

Refer to Figure 17.

Removal

- 1 Remove the case.
- 2 Remove the battery.
- 3 Disconnect the connector SK1 (1) on the LED PCB.
- 4 Disconnect the connector SK5 (2) on the Main Processor PCB.
- 5 Disconnect the connector at PL5 (3) on the Patient Trigger PCB.
- 6 Remove the input connection tube (4) by pulling the elbow off the $\frac{1}{8}$ " silicone tube, taking care not to break the barbs on the elbow.
- 7 Remove the cover (6) from the front of the FiO₂ control knob (7) and the two covers (8) from the front of the NCPAP Pres low and NCPAP Pres high flow control knobs (9) by gently prying out of the recess in the knob with a small screwdriver.
- 8 Using a screwdriver or Circle pliers, unscrew the central securing nuts for the flowmeter knobs and pull off the control knobs (9).
- 9 Using the Special wrench, unscrew the collet on the front of the FiO₂ control knob (7), remove the collet and pull off the control knob (7).
- 10 Remove the eight screws (10) from the front panel (11).
- 11 Pull the front panel assembly (11) off the frame, taking care not to damage any tubes.
- 12 Remove and discard the O-ring (12).

- 13 Remove the Valve/Sensor PCB (13) as follows:
 - a Disconnect the fuel cell connector SK1 (14) at PL1 on the Valve/Sensor PCB.
 - b Disconnect the dump/vent valve connector SK3 (15) at PL3 on the Valve/Sensor PCB.
 - c Remove the five screws (16).
 - d Pull the Valve/Sensor PCB (13) downwards and out forward to disconnect the PCB from the D plug PL2.
 - e Disconnect the exhaust tubes and the PA flow tube and remove the Valve/Sensor PCB.
- 14 At the blender, disconnect the air supply (17), the oxygen supply (18), the whistle outlet tube (19) and the main outlet (20).
- 15 Remove the four screws (21) securing the blender (22) and remove the blender. Do not remove the collet knob on the front of the blender.
- 16 Remove the pilot drive check valves as follows:
 - a Note location of cable ties securing the check valve assemblies behind the flowmeters, then cut and remove the cable ties.
 - b Hold the nut (25) and unscrew the cylinder body (23).
 - c Remove the duckbill check valves (26), guide (27) and seat (28).
 - d Discard the duckbill check valves (26).
- 17 Replace the blender check valves and filter at the blender inlet (refer to the Blender Service Manual if installing the Blender Overhaul Kit).
- 18 Replace the blender alarm bypass components (refer to the Blender Service Manual if installing the Blender Overhaul Kit).

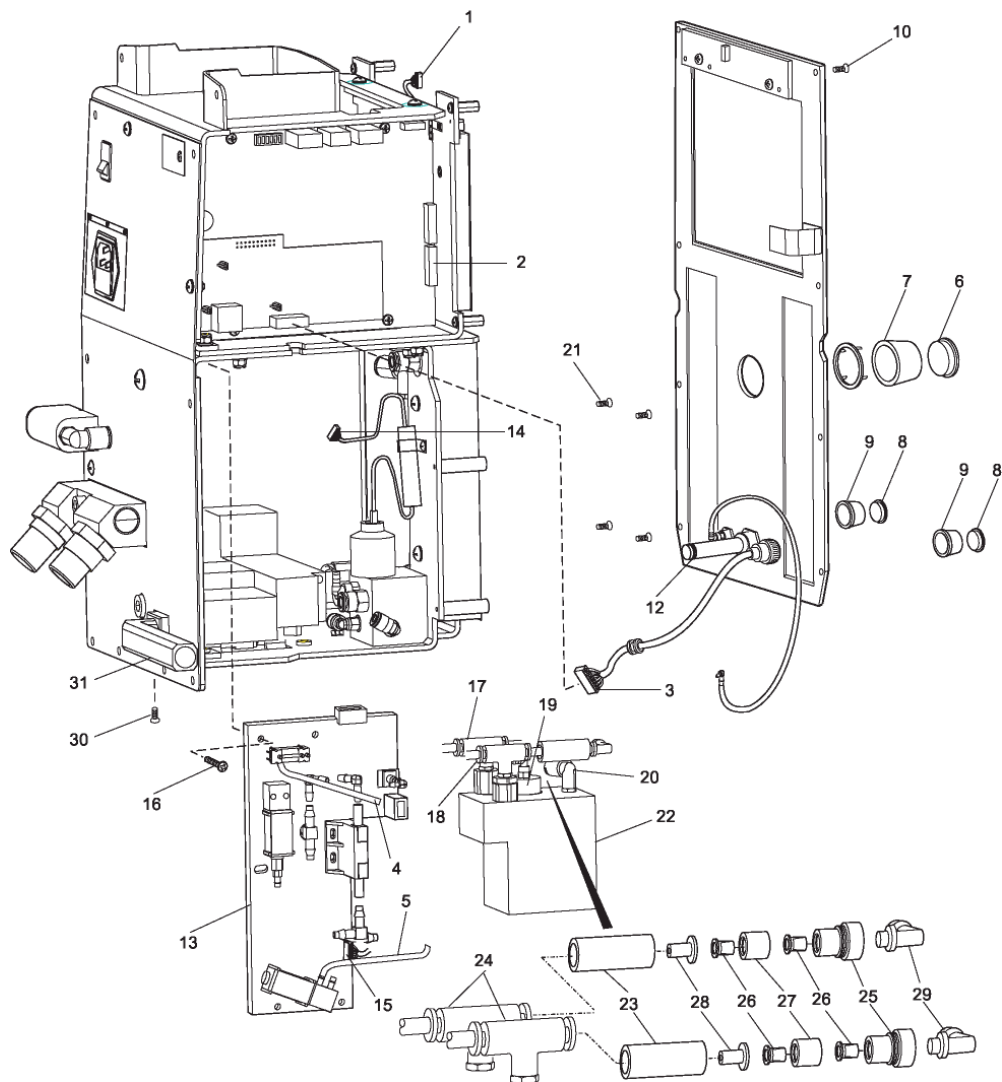

Figure 17 - Blender and Components Removal/Fitting

Fitting

- 1 Fit new pilot drive check valves as follows:
 - a Fit the seat (28), a duckbill check valve (26), the guide (27), the second duck bill check valve into the cylinder (23).
 - b Hold the nut (25) and tighten the cylinder body (23).
 - c Hold check valve assembly against cable tie mounts behind flowmeter and install new cable tie. Repeat for the other check valve assembly.
- 2 Fit the blender or refurbished blender (22) with the four screws (21) into the front frame panel.
- 3 Connect the air supply (17), the oxygen supply (18), the whistle outlet tube (19) and the main outlet (20).
- 4 Fit the Valve/Sensor PCB (13) as follows:
 - a Connect the exhaust tubes and the PA flow tube.

- b Fit the Valve/Sensor PCB (13) to the D plug PL2.
 - c Fit the five screws (16).
 - d Connect the fuel cell connector SK1 (14) at PL1 on the Valve/Sensor PCB.
 - e Connect the dump/vent valve connector SK3 (15) at PL3 on the Valve/Sensor PCB.
- 5 Fit a new O-ring (12) to the front panel assembly.
 - 6 Fit the front panel assembly (11) and install the eight screws (10).
 - 7 Set the FiO_2 collet on the blender to the 21 % position. Align the control knob (7) so that the pointer is in the 21 % position and install the control knob. Secure the control knob with the nut and tighten. Install the cover (6).
 - 8 Install the NCPAP Pres low and NCPAP Pres high flow control knobs (9) on the spindles. Using a screwdriver or Circle pliers tighten the central securing nuts. Install the covers (8).
 - 9 Install the input connection tube (4) on the elbow of the $\frac{1}{8}$ " silicone tube.
 - 10 Connect the connector at PL5 (3) on the Patient Trigger PCB.
 - 11 Connect the connector SK5 (2) on the Main Processor PCB.
 - 12 Connect the connector SK1 (1) on the LED PCB.
 - 13 Install the battery.
 - 14 Carry out an Oxygen Leak check (see Appendix A on page 69) and functional check of the IFSD and calibrate the fuel cell.
 - 15 Install the case.

Removal and Fitting of Water Trap Filter

Refer to Figure 18.

Removal

- 1 Remove the filter bowl (1) using the water trap tool included with the IFSD (P/N 673-051-A).
- 2 Pull out and discard the filter (2) from the water trap.

Fitting

- 1 Install the new filter (2) in the water trap.
- 2 Screw on the water trap bowl (1) and tighten using the water trap tool.

Removal and Fitting of Case Bleed Filtered Restrictor

Refer to Figure 18.

Removal

- 1 Remove the case and loosen the clamp securing the restrictor to sheet metal.
- 2 Note restrictor flow direction, then remove the case bleed filtered restrictor (3) from the 4mm tube.
- 3 Discard the case bleed filtered restrictor (3).

Fitting

- 1 Install the new case bleed filtered restrictor (3) to the tube in the proper orientation.
- 2 Re-secure the restrictor to the sheet metal.
- 3 Install the case.

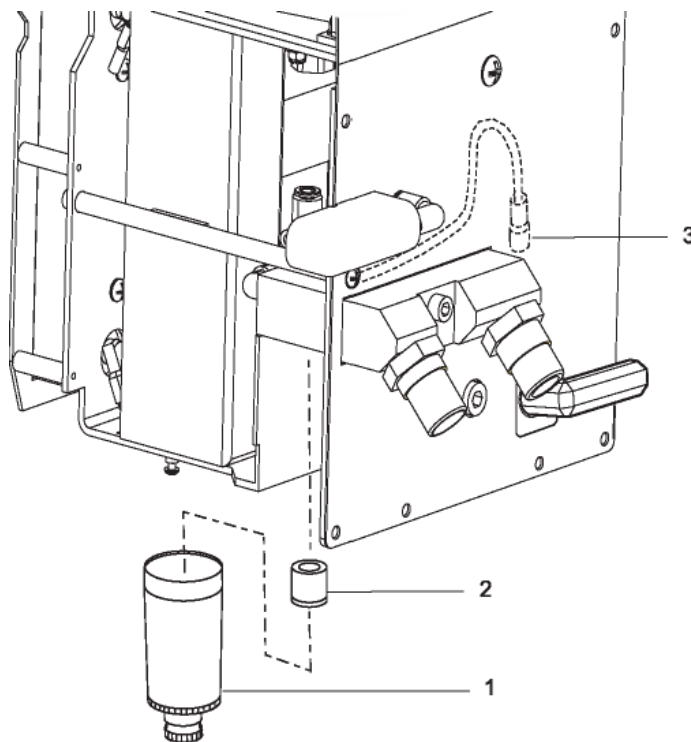

Figure 18 Water Trap Filter Removal/Fitting

Removal and Fitting of PA Solenoid Valve

The PA Solenoid Valve is replaced by replacing the Valve/Sensor PCB

Removal

- 1 Remove the case.
- 2 Remove the Valve/Sensor PCB.

Fitting

- 1 Install the new Valve/Sensor PCB.
- 2 Carry out an Oxygen Leak check (see Appendix A on page 69) and functional check of the IFSD and calibrate the fuel cell.

Firmware Reload/Upgrade

The firmware reload/upgrade uses a Software Download Utility (P/N 675-821) and a download cable (P/N 675-819). Please contact Technical Support for Security Password. To reload/upgrade the firmware:

- 1 Remove the case from the IFSD.
- 2 Connect the Download Cable to the COM port on the PC (running Windows 95 or later) and to the pin strip plug PL4 on the Main Processor PCB. Cable should only be connected/disconnected with unit turned OFF.
- 3 Switch on the PC and insert the CD into the disk drive on the PC.
- 4 Run the download program (Downloader.exe).
- 5 Select the Serial Port and Baud rate as appropriate.

Note

Auto baud rate may fail for 115200 bps on some PC's. If this happens, manually select 57600 bps.

- 6 If necessary, edit the path and file name of the hardware BSL file name and Firmware file name. Make sure that the BSL file name matches.
 - 7 Enter the serial number for the target unit (in the range 1 to 65535).
 - 8 Switch on the IFSD. Switch to Diagnostics Mode.
-

Note













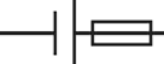

The audible alarm sounds continuously.









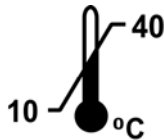

- 9 Click on the Check File button and check that the firmware file checksum and image checksum are the same.

- 10 Click on the Download button. The download takes approximately 1 minute at 57600 bps. When the download is complete, the audible alarm on the IFSD stops and the unit enters the normal operational mode.
- 11 Disconnect the Download Cable from plug PL4 on the Main Processor PCB.
- 12 Refit the case.
- 13 Carry out a functional check of the IFSD.

Chapter 8 – Explanation of Symbols

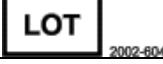



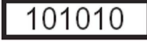













The following symbols may be referenced on the Infant Flow[®] SiPAP driver or in accompanying documentation



















Symbol	Source / Compliance	Meaning
	Symbol #03-02 IEC 60878	Indicates ATTENTION, consult ACCOMPANYING DOCUMENTS
	Symbol #5016 IEC 60417	This symbol indicates a FUSE.
	Cardinal Health Symbol	This symbol indicates an INTERNAL BATTERY FUSE
2.5A/T 250 V 101010		Fuse holder and fuse rating
		Electrical AC inlet
	Symbol #5032 IEC 60417 Symbol #01-14 IEC 30878	The equipment is suitable for alternating current.
	Symbol #5031 IEC 60417	This symbol indicates DIRECT CURRENT (DC)
	Symbol #5019 IEC 60417 Symbol #01-20 IEC 60878	This symbol indicates protective EARTH (ground).
	Symbol #5021 IEC 60417 Symbol # 01-24 IEC 60878	This symbol indicates the EQUIPOTENTIAL connection used to connect various parts of the equipment or of a system to the same potential, not necessarily being the earth (ground) potential (e.g., for local bonding).
	Symbol #5007 IEC 60417 Symbol #01-01 IEC 60878	Power ON
	Symbol #5008 IEC 60417 Symbol #01-02 IEC 60878	Power OFF
		Power ON (for part of the equipment)
		Power OFF (for part of the equipment)
	MDD Directive 93/42/EEC	CE Mark
		ETL Mark and Registration Number

Symbol	Source / Compliance	Meaning
		Operating temperature range of unit
	Cardinal Health Symbol	Warning Bell
	Cardinal Health Symbol	Respiratory Connection and Indicator
	Symbol # 5333 IEC 60417 Symbol #02-03 IEC 60878	This symbol indicates TYPE B equipment, which indicates equipment that provides a particular degree of protection against electric shock, particularly with regards to allowable leakage current and reliability of the protective earth connection.
		Type BF patient applied part
		Year of Manufacture
		Unique Batch Number Identifier
		Use Before Expiry Date shown Year-Month
		Single Use Only - Do NOT Re-use
		Keep Dry
		Keep Away from Heat
		RS232 Connection

Symbols used on buttons:

The following symbols are used to label user input areas within the graphical display. As needed displays in this table are shown separately as Domestic US configuration displays (left-hand column) and International configuration displays (right-hand column).

Symbol	Description
 	High Priority Alarm Active
 	Medium Priority Alarm Active
 	Low Priority Alarm Active; medium and high priority alarms are resolved. Alarm does not flash.
 	No alarms (active or resolved) are present
 	Active alarm silenced
	Adjust BiPhasic rate
	Adjust BiPhasic Tr backup rate
	Adjust apnea alarm timeout
	Adjust low breath rate alarm timeout
	Adjust BiPhasic, BiPhasic Tr on time, and NCPAP manual breath function
	Decrease / Increase currently selected parameter
 	Go to mode select screen.
	Nasal CPAP mode

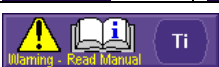
		Nasal CPAP mode with breath rate monitoring
		BiPhasic mode
		BiPhasic mode with breath rate monitoring
		BiPhasic Tr mode with breath rate monitoring
		Manual Breath. Single breath cycle at current settings for Ti, NCPAP Pres high and O ₂ %. One breath cycle is delivered regardless of button press duration
		Toggle between Main Screen and Monitored Parameter Screen
		Go to user calibration mode screen
		Confirm
		Wait
		Completed
		Action has failed
		Press to un-lock keypad
		Warning message. To clear, press any of the three icons.

Note

Provision of labeling in this manual for any function should not be taken as evidence that the function is available. For example parameter R_B relates to BiPhasic Tr mode, not currently approved for use in the US.

Appendix A – Oxygen Leak Test

Oxygen Leak Test

This test will check for leaks within the enclosure.

Test equipment needed:
Calibrated oxygen analyzer

1. Connect the driver to the air and oxygen supplies. Use adaptors to couple to the customer-specified gas block on the driver.
2. Connect the oxygen analyzer sampling tube to the driver by replacing the M6 pan screw (675-002) with an M6 fitting. Before operating the driver, take an initial O₂ concentration reading and record on TIR-004. Plug the fitting.
3. Switch the power on. The next step will setup the unit to operate in Bi-phasic mode for any Comprehensive or Plus version.
4. Set the NCPAP (Low Pressure) Flowmeter to about 8 LPM then push the soft key button below the left flowmeter icon (Figure 1).

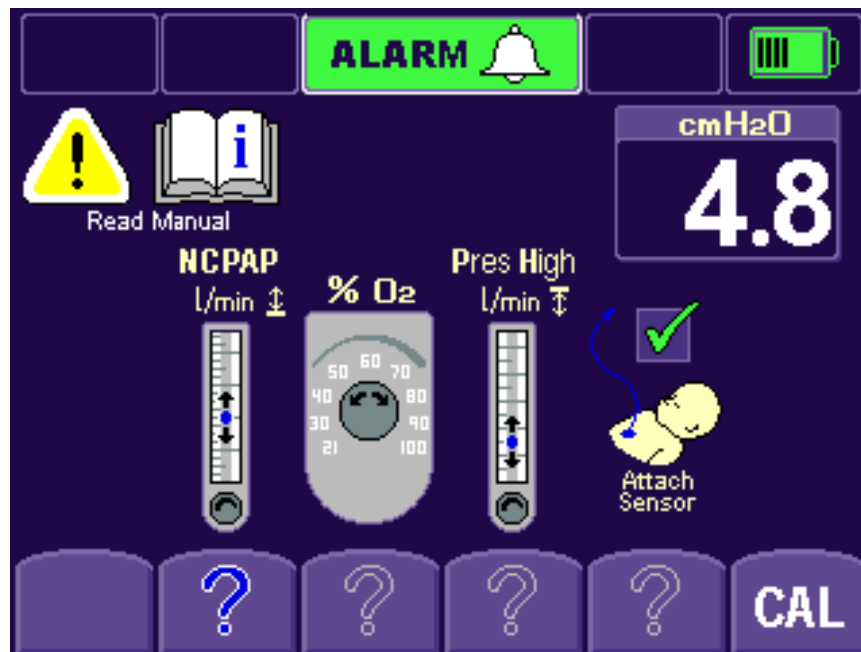

Figure 1

5. Set the %O₂ to 100% then push the soft key button below the blender icon.
6. Set the pressure High Flowmeter to about 2 LPM then push its soft key button under the right flowmeter icon.

7. The Respiratory Sensor option is not required, but to finish, select this soft key button.
8. Accept the NCPAP settings by selecting the NCPAP soft key. (%O₂ should display 100) (Figure 2).

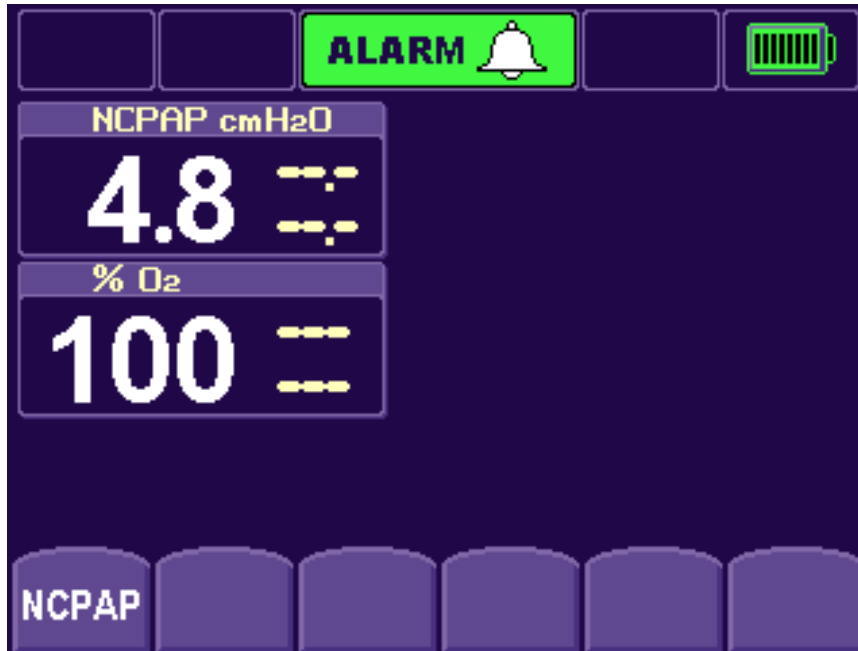

Figure 2

9. The next screen varies but select BiPhasic soft key (Figure 3).

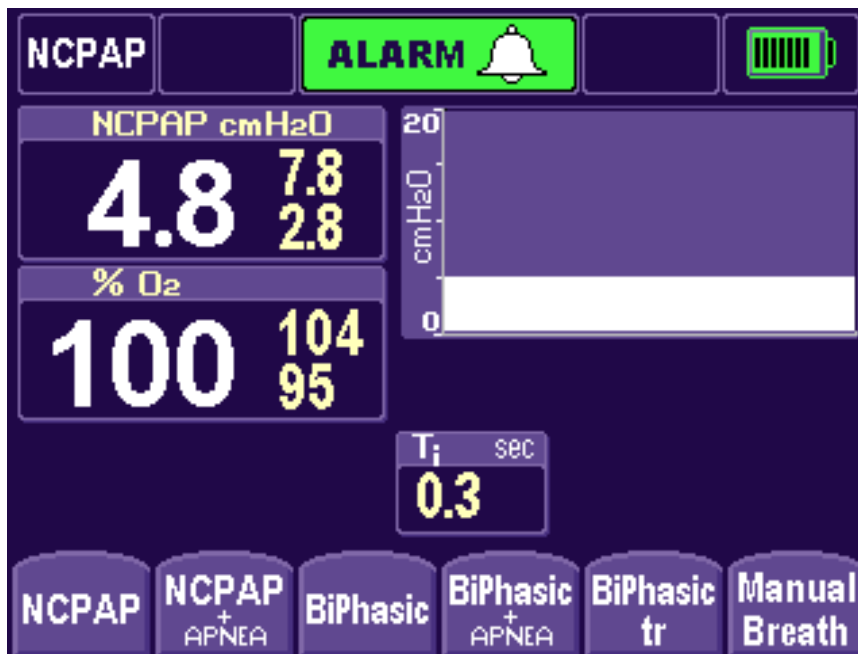

Figure 3

10. Accept the default BiPhasic settings by selecting the BiPhasic soft key again (Figure 4).

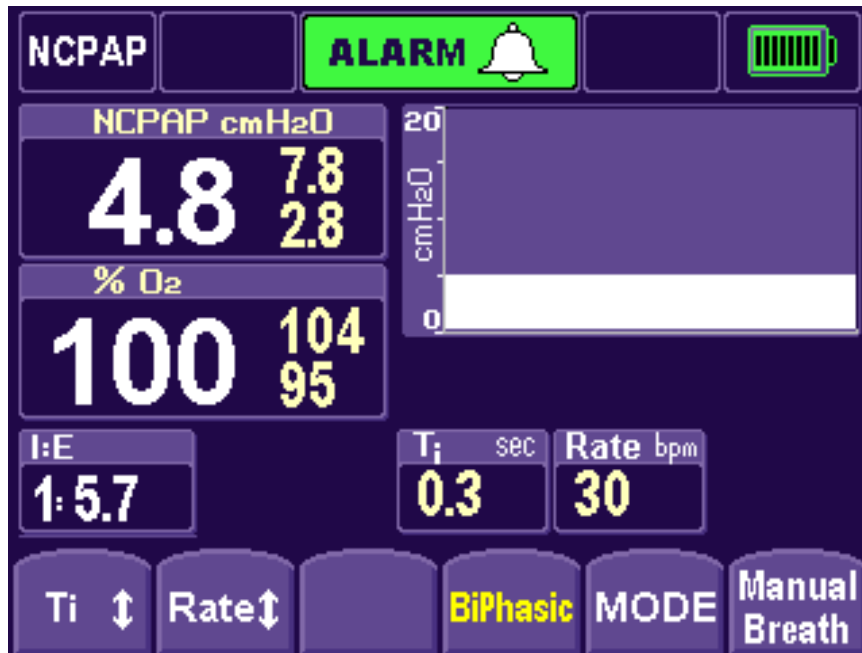

Figure 4

11. Verify that the measured value doesn't exceed 23% FiO₂. If so, then troubleshoot for an oxygen leak. Check all the fittings and connections and repeat the Oxygen Leak Test (Figure 5).

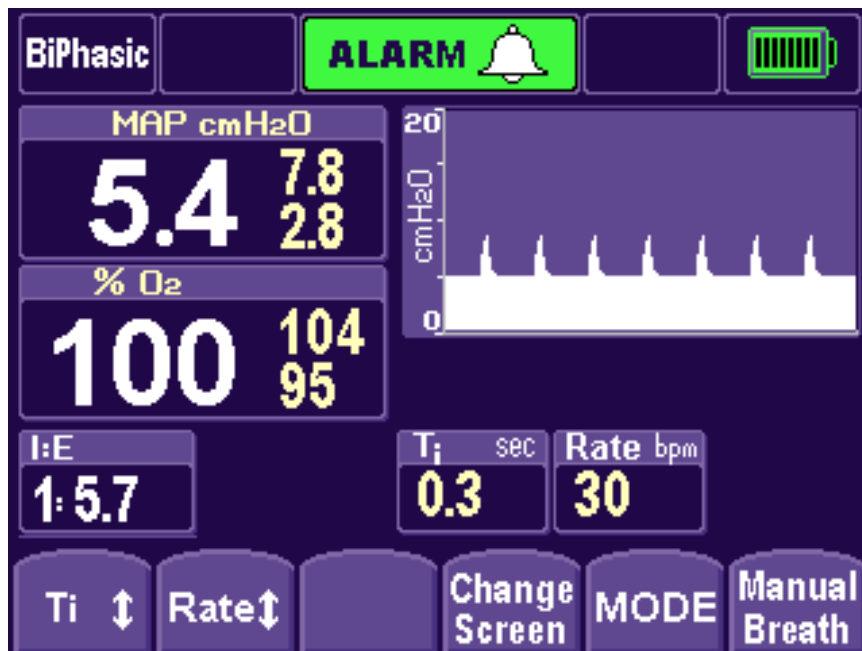

Figure 5

Infant Flow[®] SiPAP[™]
Model M675

Appendix B – Product Configurations

Non-US Configuration Parameters

Parameter	Min	Max	Accuracy	Units
Set Oxygen concentration, %O ₂	21	100	±3	%
CPAP flow rate	0	15	±15%	L/min
Bi-level additional flow rate	0	5	± 15%	L/min
BiPhasic on time, Ti (inspiration time)	0.1	3.0 *	± 0.005	seconds
BiPhasic rate, R (respiration rate)	1	120	± 0.5	pm
BiPhasic Tr backup rate, Rb (backup respiration rate)	1	120	± 0.5	pm
Breath rate timeout	10	30	± 1	seconds

* Ti automatically reduces at higher R and Rb rate settings to maintain a minimum off time of 100 milliseconds.

US Configuration Parameters

Parameter	Min	Max	Accuracy	Units
Inspired oxygen fraction, FiO ₂	21	100	±3	%
CPAP flow rate	0	15	±15%	L/min
Bi-level additional flow rate	0	5	± 15%	L/min
BiPhasic on time, Ti (inspiration time)	0.1	3.0 *	± 0.005	seconds
BiPhasic rate, R (respiration rate)	1	54	± 0.5	Pm
Breath rate timeout	10	30	± 1	Seconds

* Ti automatically reduces at higher R and Rb rate settings to maintain a minimum off time of 1000 milliseconds.

DEFAULT SETTINGS	
Inspiration Time	Ti: 0.3 seconds (1.0 sec U.S) +/- 1%.
Rate during BiPhasic modes	R: 30 / minute (10 / minute U.S.)
Back Up Rate During BiPhasic Tr	Rb: 10 / minute
Apnea Interval	T _{apnea} : 20 seconds (+/- 1%)

Infant Flow[®] SiPAP[™]
Model M675

Appendix C – Spare Parts

To identify a part referenced in this manual, refer to the associated Figure and Item number in Table 8.

Table 8 - Spare Parts

Figure	Item Number	Part Name	Part Number
13	3	Battery, Packaged	777244
14	3	Filter	06804
	4	O-ring, 7/16" x 9/16"	465476
15	3	Filter/Restrictor	672-024-SA
	4	O-ring, 1/8" x 1/4"	465474
	5	O-ring, 1/4" x 3/8"	465457
16	4	Fuel Cell	68289
17	12	O-ring, 7/16" x 9/16"	465476
	13	Valve/Sensor PCB Assembly, Packaged	777245
	22	Blender	11329
	26	Pilot Drive Check Valves	675-230
18	2	Water Trap Filter Element	467269
	3	Case Bleed Filtered Restrictor	467542

Additional Service Parts:

Part Number	Description
467472	BLENDER CONTROL KNOB
467468	CAP, BLENDER CONTROL KNOB
467471	POINTER, BLENDER CONTROL KNOB
467469	FLOWMETER KNOB
467470	CAP, FLOWMETER KNOB
675-308	CASE
467467	FOOT, POLYURETHANE .50D
467466	WASHER M3 CRINKLE BECU (FOR CASE)
675-200	FLOWMETER MK3 HIGH
675-201	FLOWMETER MK 3 LOW
09220	FLOWMETER, AUXILIARY
777244	PACKAGED BATTERY, MK3
47072	SPACER ROUND M4X155MM NYLON
467595	COMPRESSION PAD
465464	FILTER, WATERTRAP
673-051-A	WATERTRAP TOOL
465476	O-RING, PATIENT CONNECTOR
672-024-SA	ASSEMBLY, FILTER
465457	O-RING, O2 SCREW/FLOWMETER/GAS BLOCK
465474	O-RING, O2 FILTER
467352	FUEL CELL
675-230	PILOT DRIVE DUCKBILL ASSY
467542	CASE BLEED FILTER RESTRICTOR
777245	VALVE/SENSOR PCB (PACKAGED ASSEMBLY)
677-005-A	PATIENT TRIGGER CONTROLLER PCB
675-311	PATIENT TRIGGER CABLE
S117635	ASSY PCB MAIN PROCESSOR
467461	LCD 5.5 INCH
467460	PCB BACKLIGHT INVERTER LCD
675-260	LCD CABLE 12
675-257	LED BOARD CABLE-6
467459	FUSE TIME LAG 2.5A 250V
467458	POWER INPUT TWIN FUSE
675-307	AUX FLOW MOUNTING BLOCK
11329	ASSY BIRD BLENDER
10003	MAINT KIT MCRBLNDR+LOFLO
675-300	EXHAUST TUBE 90 DEGREE
675-101-xxx	OPS MAN INF FLOW SiPAP
677-002	TRANSDUCER INTERFACE
467349	ABDOMINAL RESP SENSOR 25PK

Part Number	Description
03895	VALVE CHECK DCKBL BLACK
06804	FILTER NYLON CONE INL
467269	FILTER ELEMENT (WATERTRAP)
777235	POWER SUPPLY MK3
467455	SWITCH COVER
675-256	SWITCH CABLE ASSY
S117641	ASSY PCB LED AMBIENT SENSOR
675-310	FRONT PANEL
675-312	CONNECTOR PATIENT INLET
675-316	MK3 TRIGGER LEUR
675-209	O ₂ SENSOR CABLE
777072-xxx	BLOCK, INLET O ₂ /AIR System
777242-101	SERVICE KIT, Mk3 DRIVER ANNUAL
777242-103	SERVICE KIT, Mk3 DRIVER 5 YEAR
777072-101	ASSY O ₂ /AIR FITTINGS MARK III DISS
777072-102	ASSY O ₂ AIR FITTINGS MARK III NIST
777072-103	ASSY O ₂ /AIR FIT MARKIII FEMALE DISS
777072-103	ASSY O ₂ AIR FIT MARKIII AIR LIQUIDE
675-821	SWR MK3 IFD DOWNLOAD UTILITY
675-819	MK3 DOWNLOAD CABLE
461964	CABLE TIE, BATTERY
52000-00239	CABLE TIE, CHECK VALVE ASSEMBLY
11431	ASSEMBLY, AUXILLIARY FLOWMETER

Infant Flow[®] SiPAP[™]
Model M675

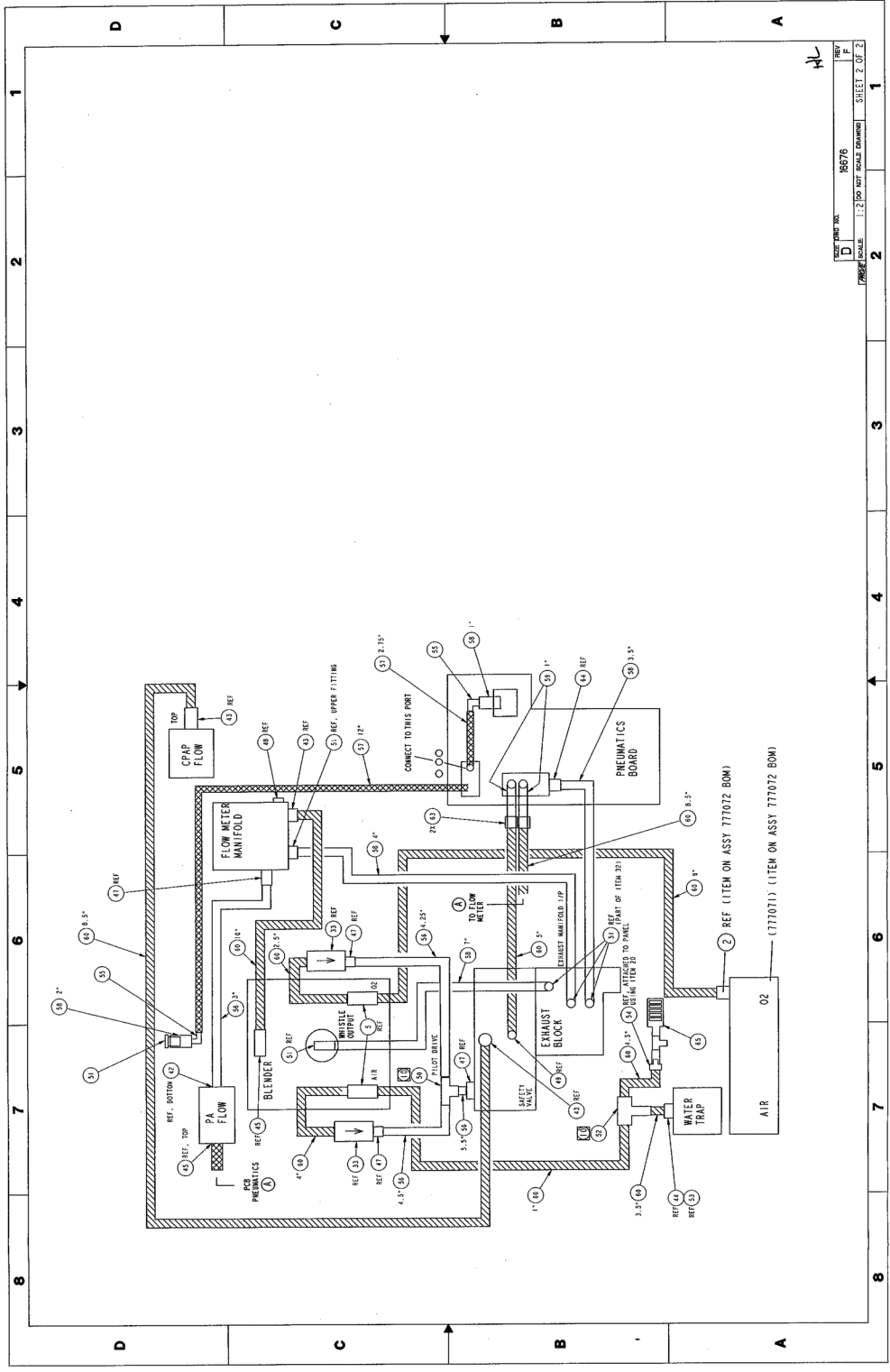

Glossary

Term	Meaning
Apnea	Temporary inability to breathe; monitoring of breathing (non-US labeling)
Bpm	Breaths per minute (applies to each of spontaneous, triggered and mandatory)
Bps	Bytes per second
cmH ₂ O	Centimeters of Water (Pressure)
CPAP	Continuous Positive Airway Pressure
FiO ₂	Fraction of Inspired Oxygen
Generator	Patient attachment for delivering CPAP, used with nasal prongs or mask
I/E	Inspiration/Expiration ratio
IFSD	Infant Flow SiPAP Driver
LBR	Low Breath Rate monitoring (US labeling)
L/min	Liters per minute
MAP	Mean Airway Pressure
BiPhasic	BiPhasic Ventilation - CPAP with additional pressure pulses, time-triggered and time-cycled
BiPhasic+Apnea	BiPhasic Ventilation with Apnea monitoring (non-US labeling)
BiPhasic +LBR	BiPhasic with low breath rate monitoring (US labeling)
BiPhasic Tr	Triggered BiPhasic Ventilation - CPAP with additional pressure pulses, patient-triggered and time-cycled
NCPAP	Nasally applied CPAP
NCPAP+LBR	NCPAP with Low Breath Rate monitoring (US labeling)
NCPAP+Apnea	NCPAP with Low Breath Rate monitoring (non-US labeling)
Non-US labeling	Labeling using non-linguistic symbols in place of English text
PEEP	Positive End-Expiratory Pressure
PIP	Peak Inspired Pressure
BiPhasic Flow	Inspiratory Pressure
PRS	Product Requirement Specification. A fully controlled baseline document
Rate	Mandatory BiPhasic rate (per minute)
R _B	Backup ventilator rate (in BiPhasic Tr mode during apnea alarm, per minute; non-US labeling)
R _{SP}	Patient's spontaneous respiratory rate (per minute)
s / sec	Seconds
Sigh	A single pulse of additional gas flow

Term	Meaning
T _{apnea} / T _{LBR}	Apnea Interval (non-US labeling) or Low Breath Rate (LBR) monitor alarm time (US-labeling); both in seconds This mnemonic may also be associated with an alarm icon 
Ti	Machine breath inspiration time (seconds)
Treatment	Application of NCPAP, BiPhasic, BiPhasic Tr, with or without breath monitoring, to the patient
US labeling	Labeling using English text in place of symbols and/or icons