

SLE

SLE 2000 Ventilator

Service manual



Infant Ventilator

CE 0120



Contact Information:

SLE Limited
Twin Bridges Business Park
232 Selsdon Road
South Croydon
Surrey CR2 6PL

Telephone: **+44 (0)20 8681 1414**

Fax: **+44 (0)20 8649 8570**

E-mail: **admin@sle.co.uk** (E-mail's should be addressed to the Service Manager)

Web site: **www.sle.co.uk**

All rights reserved. No part of this publication may be reproduced, stored in any retrieval system, or transmitted in any form or by any means, electronic, mechanical, photocopy, recording or otherwise, without prior permission of SLE. © Copyright SLE 01/10/2004.

Manual : **SM0007 Issue 7**

SLE Part N°: **N2002**

Contents

1. Introduction	8
2. Principles of Operation SLE2000 Valveless System	8
3. User/Owner Responsibility	10
4. Warnings	11
5. Symbols Used on or in the Equipment	12
6. Glossary Of Abbreviations	13
7. Ventilator Control Description	16
7.1. Front Panel	16
7.2. Function of Front Panel Controls and Indicators	17
7.3. Rear Panel	19
7.4. Side panel.....	20
8. Accessing the SLE2000 Internal Components.	22
8.1. ELECTRONIC MODULE	22
8.2. PNEUMATIC MODULE	22
8.2.1. To Remove The Main PCB (A0702/01)	23
8.3. To Separate The Two Modules.....	24
8.4. Removal Of The Oxygen Blender.....	25
8.5. Removal of the Oxygen cell.....	26
8.5.1. Oxygen Cell Mounting	26
9. Maintenance	30
9.1. Cleaning, Disinfection and Sterilization	30
9.1.1. Preparation of a new ventilator	30
9.1.2. Cleaning and disinfection of an in-service ventilator.....	30
9.1.3. Cleaning, Disinfection & Sterilization chart	31
9.1.4. Cleaning method.....	31
9.1.5. Disinfection method	32
9.1.6. Sterilization method	32
9.2. Filter Systems.....	33
9.2.1. Bacterial filter, SLE Part N ^o :N2029 (Autoclavable)	33
9.3. Bacterial filter, SLE Part N ^o :N2587 (Single use).....	33
9.3.1. Precautions when using bacterial filter N2587.....	33
9.4. Monthly Operational Checks	34
9.4.1. Battery condition and LED display test.	34
9.4.2. Air and Oxygen Supply Failure Alarm test.....	34
9.4.3. Condition of O ₂ Cell	34
9.4.4. Proximal Airway Pressure Gauge Accuracy	34



9.4.5. Inspiratory Nozzle	34
9.5. Preventative Maintenance	35
9.6. Overhaul	35
9.6.1. Service Parts List	36
10. Test Equipment Required	38
11. Electronic Module	39
11.1. Description of Operation	39
11.2. Electronic Module Calibration Procedure.....	41
11.2.1. Preliminary Checks and Adjustments	41
11.2.2. System watchdog.....	41
11.2.3. Pressure Transducer PTR1 to ADC	41
11.2.4. Pressure Transducer Buffered Output	41
11.2.5. CPAP Alarm Set Point Control	42
11.2.6. PIP Control.....	42
11.2.7. Inspiration Time.....	42
11.2.8. Alarm Volume.....	42
11.2.9. Fresh Gas Block and leak Alarm.....	43
11.2.10. FIO ₂ Digital Display	43
11.2.11. Airway Trigger Calibration	43
11.3. SLE 2000 Electrical Troubleshooting Chart	45
12. Pneumatic Module	46
12.1. Description of Operation	46
12.2. Fresh Gas System	48
12.3. CPAP System	49
12.4. Inspiratory System.....	50
12.5. Pneumatic Calibration Procedure	51
12.6. Pneumatic Circuit Diagram.....	52
12.7. Pneumatic Module Parts List.....	53
12.8. SLE 2000 Pneumatic Troubleshooting Chart	55
13. Technical Specification	58
13.1. Conventional Ventilation	58
13.2. Displays	58
13.3. Controls	59
13.4. Alarms	59
13.5. Power , Dimensions etc.....	60

14. Electronic Circuit Details	62
14.1. Display Board A0700/01	62
14.1.1. Display Board Circuit Diagram A0700/01	63
14.2. LED Board A0701/01	65
14.2.1. LED Circuit Board Diagram CD/A0701/01	66
14.3. Ventilator CPU Board AS/A0702/01 Issue 4.....	69
14.3.1. Ventilator CPU Board CD/A0702/01 Issue 2 Sheet 1 of 3	70
14.3.2. Airway Trigger Circuit Diagram CD/A0702/01 Sheet 2 of 3	71
14.3.3. Window Pressure Alarm A0702/01 Sheet 3 of 3	72
14.4. Ventilator CPU Board AS/A0702/01 Issue 5.....	76
14.4.1. Ventilator CPU Board CD/A0702/01 Issue 6	77
14.5. Ventilator CPU Board AS/A0702/01 Issue 5.....	81
14.5.1. Ventilator CPU Board (Detail A).....	82
14.5.2. Ventilator CPU Board CD/A0702/01 Issue 7	83
14.6. RS232/423 Option	88
14.7. Power Supply, Alarms and Oxygen Signal Conditioner (A0703).....	90
14.7.1. Power Supply Circuit Diagram CD/A0703/01	91
14.8. CD/W0288 Wireloom.....	94
14.9. Electronic Chassis	95
14.9.1. Electronic Chassis	96
15. A3 Circuit Diagram Appendix	99
16. Service Information and Technical bulletins	112
16.1. Service Information	113
16.1.1. SI 980301 Ventilator Alarms and INOSYS Nitric Oxide Delivery System ..	113
16.1.2. SI 980302 Ventilator oxygen cells (N2191).....	115
16.1.3. SI 990302 Possible inadvertant solenoid failure messages	116
16.1.4. SI 000201 Leak Alarm Trigger Threshold.....	118
16.1.5. SI 020901 Cleaning, Disinfection and Sterilisation of SLE ventilators.....	120
16.1.6. SI 031101 N2183 0-4 bar pressure gauge.....	121
16.2. Technical Bulletins	122
16.2.1. TB 990603 Removal of hour counter from electrical chassis.	122
16.2.2. TB 000201 New versions of control software.	123
16.2.3. TB 000801 Ventilator Firmware Status	124
16.2.4. TB 040301 SLE2000 CPU Boards	127
16.2.5. TB 040401 V0226 Potentiometer	129
17. Issue Revision Record	130
18. Index	131



This page is intentionally blank.



Introduction



1. Introduction

The SLE2000 is a constant flow, time cycle, and pressure limited neonatal ventilator with patient triggering.

Main features are that it has no expiratory valve but uses a reverse flow of mixed gas that is injected from the exhaust manifold into the expiratory limb of the patient circuit. This flow of gas has the effect of compressing 5 LPM humidified gas into the patient ET tube.

The advantage of this system is that there is no expiratory resistance due to valves or diaphragms, therefore no inadvertent PEEP is generated.

2. Principles of Operation SLE2000 Valveless System*

The patient circuit is supplied with a constant fixed flow of 5LPM fresh gas. This gas comes from the internally mounted oxygen blender and its concentration is also monitored by a fuel cell and displayed on the FIO₂ digital display. This fresh gas supply is then passed through a humidifier to the inspiratory port of the patient ET connector. Built into the ventilator are circuits to detect either a gas flow failure or a tubing blockage. The patient circuit requires a restrictor fitted into the inspiratory port. Therefore, only SLE approved patient circuits must be used.

The Expiratory limb of the patient circuit is connected to the Exhalation port on the ventilator. This consists of a removable block mounted on a manifold, accessed by lowering the left hand side cover. The expiratory manifold has two nozzles. The front one to generate CPAP/PEEP and is supplied via the CPAP regulator on the front panel of the Pneumatic Module. The rear one to generate peak inspiratory pressure(PIP).

To avoid the possibility of gas dilution these regulators are supplied with the same oxygen concentration as the Fresh Gas supply . The front nozzle is used to generate an opposing flow to the Fresh Gas in the exhalation block and thus create CPAP The rear nozzle is used to generate the peak inspiratory pressure in the same way, supplying constant pressures at all breathing rates.

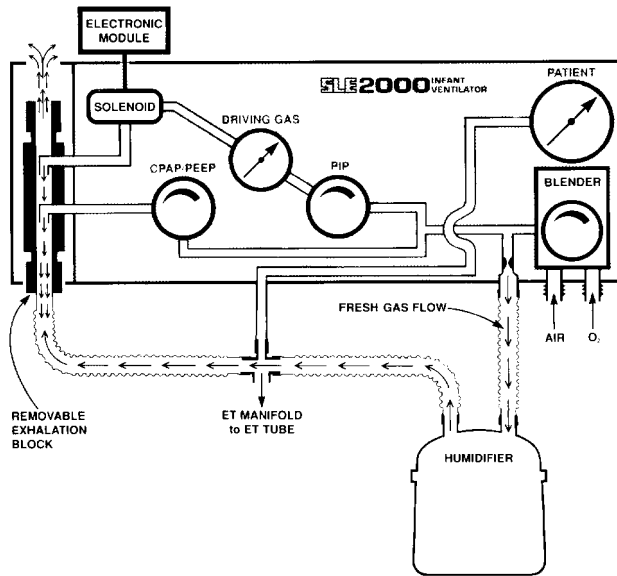

The PIP regulator and gauge on the front panel set the pressure that is supplied to a solenoid valve which is connected to the rear nozzle. The Electronic Module controls the rate and duration of the flow of Driving Gas into the Exhalation block in opposition to the Fresh Gas flow. This opposing flow acts as a pneumatic piston and creates a pressure wave at the ET manifold. The lung inflation pressure and hence the tidal volume are controlled by the PIP regulator.

NOTE: The ventilator should be set to a square waveform for breathing rates above

60 BPM

* The Valveless Ventilation Principle was designed and patented by Prof. J G Whitwam and Mr. M. K. Chakrabarti of the R.P.G.M.S Hammersmith Hospital. This patent is exclusively licensed to SLE



3. User/Owner Responsibility





This SLE 2000 INFANT VENTILATOR equipment and the authorised accessories for it are designed to function as specified in the relevant instruction manual only when operated, maintained and repaired in accordance with supplied manuals and instructions. This equipment must be periodically checked, recalibrated, maintained and components repaired and replaced when necessary for the equipment to operate safely and reliably. Parts that have failed, in whole or in part, or exhibit excessive wear, or are contaminated, or are otherwise at the end of their useful life should not be used and should be replaced immediately with parts supplied by SLE or parts which are otherwise approved by SLE. Equipment which is not functioning correctly or is otherwise in need of repair or maintenance must not be used until all necessary repairs and/or maintenance have been completed and a factory authorised service representative has certified that the equipment is fit and ready for use. This equipment and any of its accessories or component parts should not be modified.

The owner/user of this equipment shall have the sole responsibility and liability for any damage or injury to persons or property (including the equipment itself) resulting from operation not in accordance with the operating instructions, or from faulty maintenance not in accordance with the authorised maintenance instructions, or from repair by anyone other than a factory authorised service representative, or from unauthorised modification of the equipment or accessories, or from the use of components or accessories that have either been damaged or not authorised for use with this equipment by the factory.

4. Warnings

- 1 Oxygen - Clinical use. Oxygen is a drug and should be prescribed as such.
- 2 Oxygen - Fire Hazard. Oxygen vigorously supports combustion and its use requires special precaution to avoid fire hazards. Keep all sources of ignition away when oxygen is in use. Do Not use oil or grease on oxygen fittings or where oxygen is used.
- 3 The ventilator functional tests must be carried out each time the SLE 2000 is used on patients. If any of these tests do not function as described then there is a problem and the ventilator must not be used until it is rectified.
- 4 The humidifier used in the patient circuit must be operated and maintained in accordance with its manufacturer's instructions. It is the owners responsibility to ensure that the equipment is regularly maintained.
- 5 Failure to comply with the recommended service programs could lead to injury to the patient, operator or damage to the ventilator. It is the owners responsibility to ensure that the equipment is regularly maintained.
- 6 Functioning of this ventilator may be adversely affected by high frequency surgical (Diathermy) , defibrillators, mobile phones, short-wave therapy or equipment producing strong magnetic fields, operating the in vicinity.
- 7 The Ventilator must be plugged into a suitably rated and grounded electrical power source.
- 8 There is no special protection provided against ingress of water or liquids.
- 9 The equipment is not suitable for use with, or in the presence of flammable anaesthetic mixtures.
- 10 Use only SLE approved patient circuits. On no account should antistatic or electrically conductive tubing be used in the patient circuit.
- 11 No external voltage should be applied to the auxiliary socket. Any connections to this socket must be approved by SLE and screened to comply with EMC regulations. Ensure protection cap is fitted when socket is not in use.
- 12 The electronic module of the ventilator contains a primary battery for mains failure alarm, if the ventilator is not to be used for 3 months or more, then the battery should be removed.
- 13 Care should be taken when attaching other equipment as this may affect stability.
- 14 If the SLE 2000 Infant Ventilator is adversely affected by equipment emitting electromagnetic interference then that equipment should be switched off or removed from the vicinity of the 2000. Conversely, if the 2000 is the source of such interference to neighbouring equipment then it should be switched off or taken to another location.

5. Symbols Used on or in the Equipment

	<p>Protective Earth</p>
	<p>Attention, Consult accompanying documents.</p>
	<p>B.S.I. and I.E.C. symbol for equipment with type B (non isolated parts).</p>
	<p>WARNING : - No external voltage should be applied to the auxiliary socket.</p>
	<p>WARNING : - The electronic module contains a primary battery. If the unit is not to be used for a period exceeding 3 months, it is recommended that the battery be removed.</p>
<p>Mains Fuses</p>	<p>Two externally accessible fuses are;</p> <p>Type T 0.2 amps. For 200 - 250V Type T 0.5 amps. For 100 - 120V</p>

6. Glossary Of Abbreviations

amp	Ampere
BPM	Breaths Per Minute
cm	Centimetre
cmH ₂ O	Centimetres of Water Pressure
CMV	Continuous Mandatory Ventilation
CPAP	Continuous Positive Airway Pressure
°C	Degrees Centigrade
°F	Degrees Fahrenheit
DISS.....	Diameter Index Safety System
ETO.....	Ethylene Oxide
ET	Endotracheal
Exp.....	Expiration Time
FIO ₂	Fractional concentration of Inspired Oxygen
Hz.....	Hertz
ID	Internal Diameter
I:E.....	Inspiratory : Expiratory ratio
Insp	Inspiration Time
IMV.....	Intermittent Mandatory Ventilation
MAP	Mean Airway Pressure
IPPB.....	Intermittent Positive Pressure Breathing
IPPV.....	Intermittent Positive Pressure Ventilation
kg	Kilogram
lb	Pound
LPM.....	Litres per Minute
Peak.....	Peak Airway Pressure
ml	Millilitre
O ₂	Oxygen
PEEP	Positive End Expiratory Pressure
PSI	Pounds per Squire Inch
psig	Pounds per Squire Inch Gauge
SIMV	Synchronous Intermittent Mandatory Ventilation
VAC.....	Volts, Alternating Current
Vt.....	Tidal Volume
Nist.....	Non interchangeable Standard Terminal
PTV	Patient Triggered Ventilation
PIP	Peak Inspiratory Pressure
ms	Millisecond



This page is intentionally blank.

**Ventilator Control
Description**

7. Ventilator Control Description

The SLE 2000 consists of two linked modules, Electronic and Pneumatic.

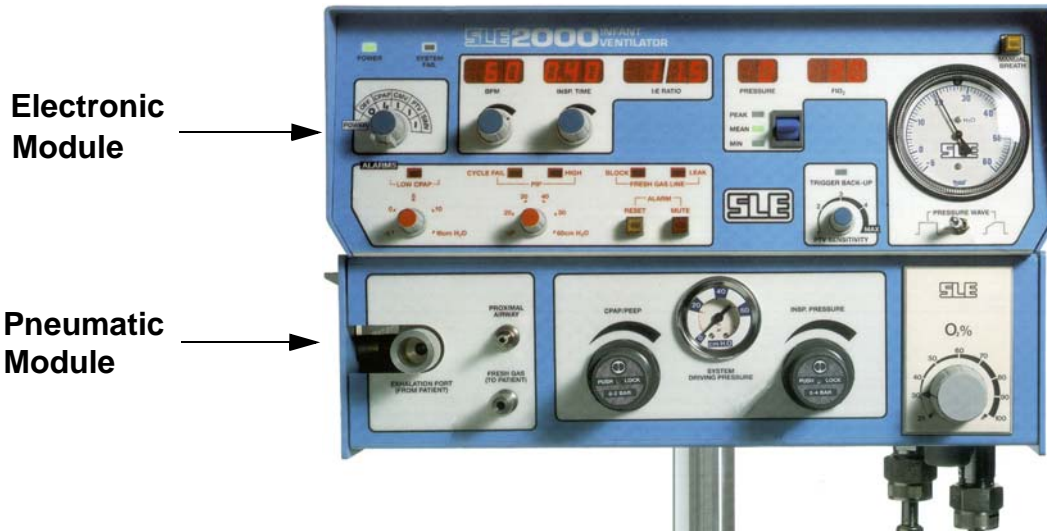

7.1 Front Panel

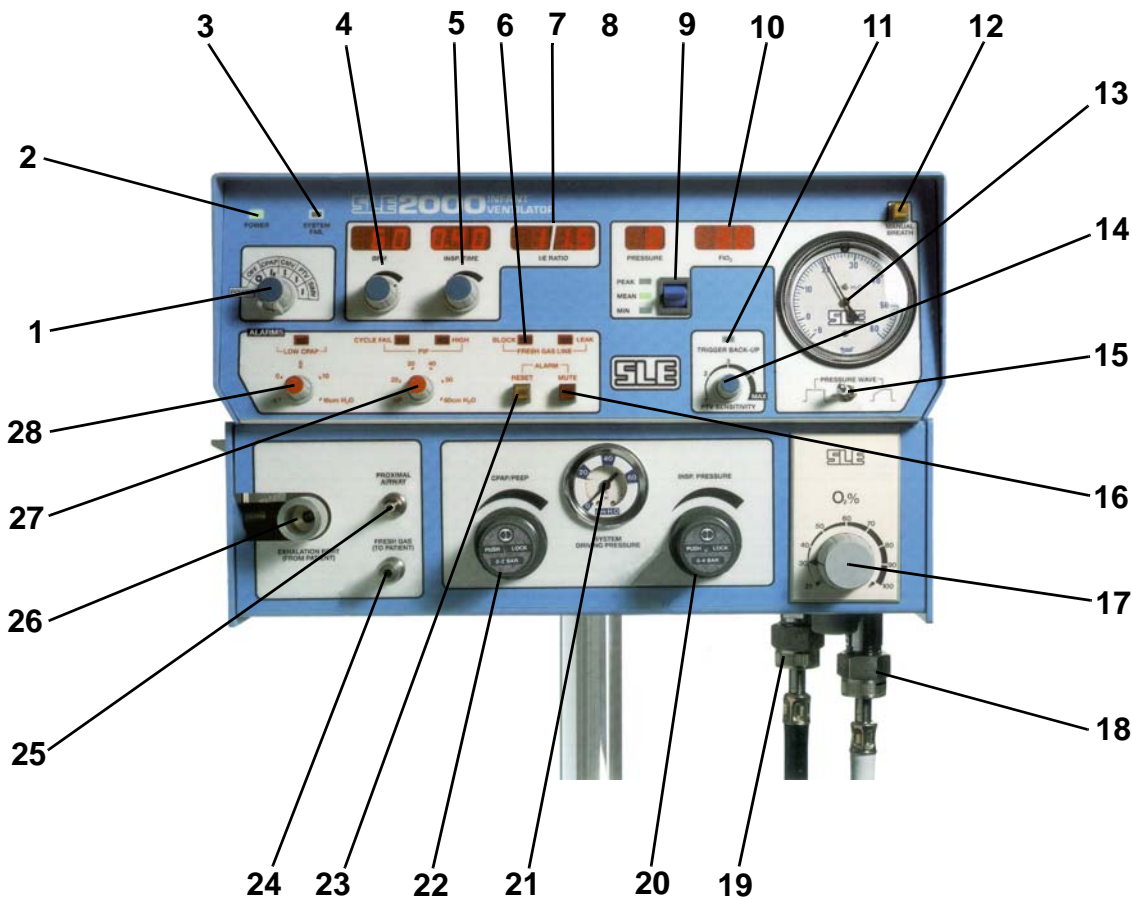

7.2 Function of Front Panel Controls and Indicators

Nº	Item	Description
1	POWER and OPERATIONAL MODE Switch	Selects Power OFF, ALARM TEST/CPAP, CMV, PTV, SIMV modes.
2	POWER LED	Indicates power is 'ON'.
3	SYSTEM FAIL LED	When this LED lights and the alarm sounds, it indicates failure of the main processor. If this happens, the ventilator must be removed from service.
4	BPM digital display with adjustment knob	Displays between 1-250 BPM. Available in two ranges: 1-125 BPM & 126-250 BPM, selectable by rear security key switch
5	INSP. TIME digital display with adjustment knob	Inspiratory Time Displays 0.1-3.0 seconds in 1-125 BPM range or 0.01-0.3 seconds in 126-250 BPM range.
6	FRESH GAS BLOCK audible alarm.	Indicates problems within the patient circuit line.
7	I:E RATIO digital display	Displays from 9.9:1 to 1:9.9 calculated from BPM and insp. time
8	LEAK LED's audible alarm.	Indicates problems within the patient circuit line.
9	MAX MEAN MIN switch with digital PRESSURE display	Selects and displays Max., Mean or Min airway pressures.
10	FIO ₂ digital display	Accurately displays the % O ₂ as set by the Air-Oxygen Blender.
11	TRIGGER BACK-UP LED	Indicates a machine-delivered breath due to patient failure to trigger ventilate or during back-up time window.
12	MANUAL BREATH Pushbutton	Causes delivery of a single breath in CPAP, CMV and PTV modes to preset inspiration times and pressures.
13	Pressure Gauge -6 to +60 cmH ₂ O.	Proximal Airway Pressure. This pressure is displayed more accurately by the independent digital display.
14	PTV SENSITIVITY control	Variable patient trigger level setting. Sensitivity between 1 (least sensitive to patient effort) and 5 (most sensitive to patient effort).

Nº	Item	Description
15	PRESSURE WAVE switch	Permits change of leading edge of pressure wave from square to taper in 1-125 BPM range only.
16	ALARM MUTE Pushbutton and LED	Mutes audible alarms for one minute.
17	AIR OXYGEN BLENDER control	Sets air/oxygen mix between 21 and 100% O ₂ ± 3% with digital indication from independent monitoring circuits.
18	O ₂ inlet	O ₂ hose connector.
19	Medical air inlet	Medical air hose connector.
20	Inspiratory Pressure Regulator	Adjusts driving pressure to set circuit inspiratory pressure. Range 0-60 cmH ₂ O.
21	SYSTEM DRIVING PRESSURE gauge	Approximate indication of the pressure above PEEP which will be delivered to the patient in CMV, PTV, SIMV or manual breath modes.
22	CPAP/PEEP regulator	Sets CPAP level in the circuit, range is 0 to 15 cmH ₂ O (nominal).
23	ALARM RESET Pushbutton	Resets audible and visual alarms.
24	Fresh Gas Port	5LPM blended gas supply to patient (ventilator powered up). 1LPM blended gas supply to patient (ventilator OFF)
25	Proximal airway	Proximal airway tube connector.
26	Exhalation block	Connection for expiratory limb of patient circuit.
27	PIP, CYCLE FAIL and HIGH alarm LED's with control	Sets visual and audible alarm level for inspiratory pressure between 0 and 60 cmH ₂ O.
28	CPAP Alarm LED and control	Sets visual and audible alarm level for CPAP pressure.

7.3 Rear Panel

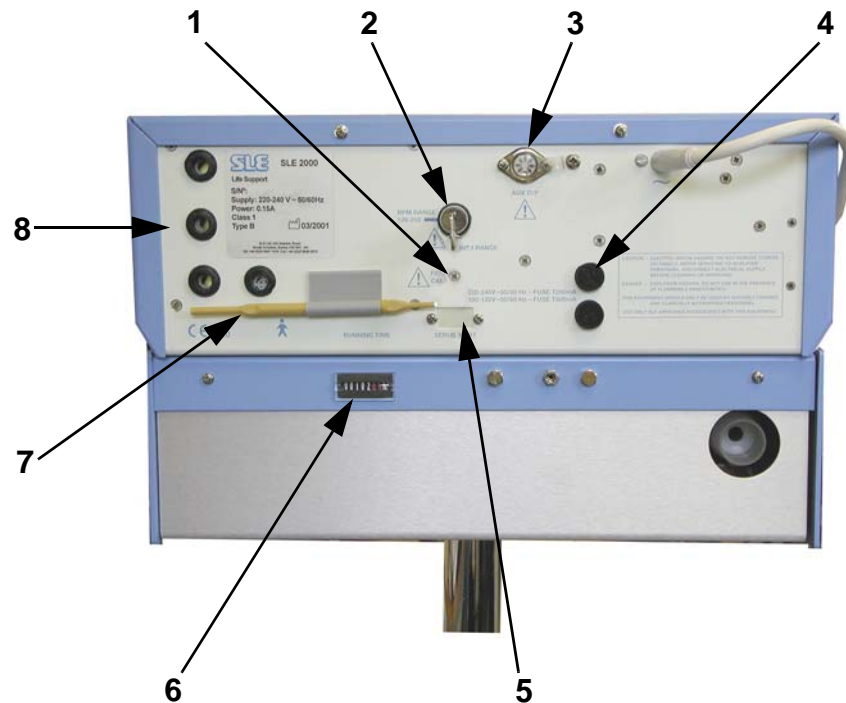

N ^o	Item
1	FIO ₂ calibration adjustment.
2	125 - 250 BPM range switch
3	Aux. Output socket.
4	Fuse Holders
5	Optional serial port
6	Running Time Indicator
7	FIO ₂ adjustment tool.
8	Alarm sounder

7.4 Side panel

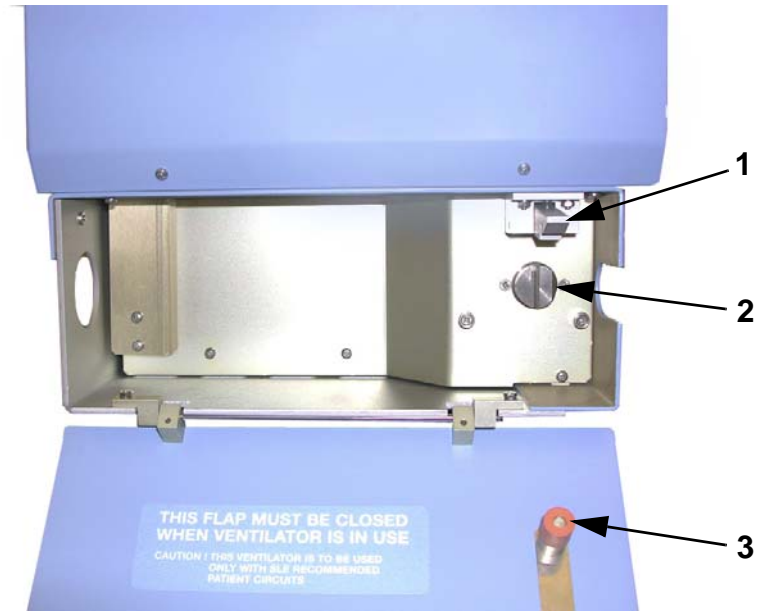

N°	Item
1	Side flap latching mechanism.
2	Fixed jet.
3	Expiratory tube guide.



**Access to Internal
Components**

8. Accessing the SLE2000 Internal Components.

Caution: All electrical and pneumatic connections must be disconnected before attempting to gain access to either Electronic or Pneumatic modules.

8.1 ELECTRONIC MODULE

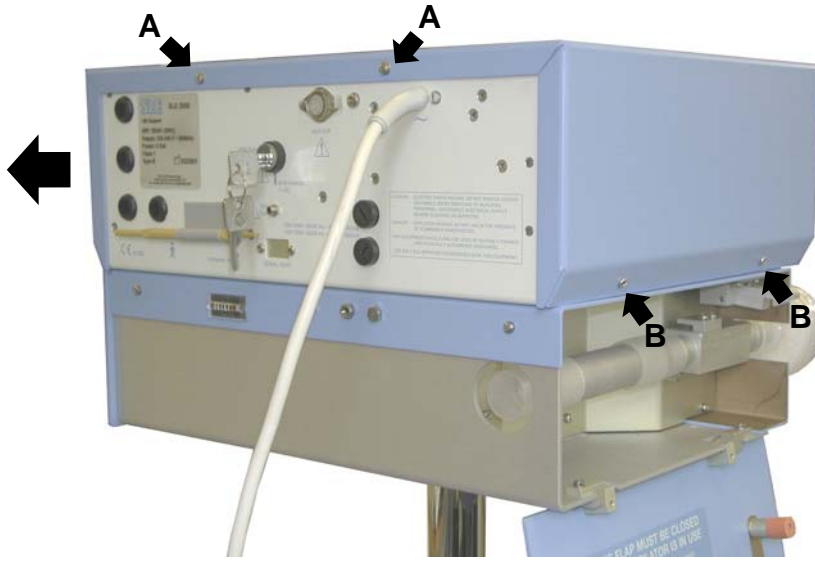

1. Remove 2 screws at rear (A) and 2 screws at each side of the unit (B).
2. Slide top cover to rear and remove.

8.2 PNEUMATIC MODULE

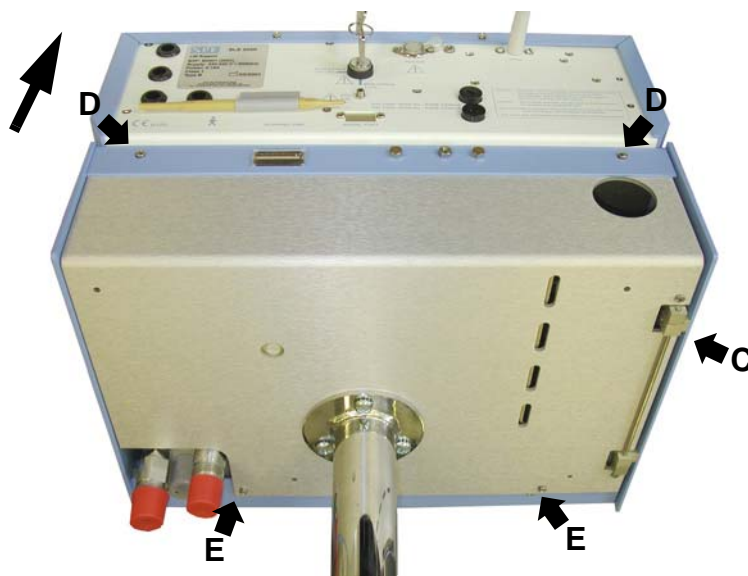

1. Open Side Flap (C).
2. Remove 2 screws at rear (D) and 2 screws at base of unit (E).
3. Lift complete unit from base and turn upside down.

8.2.1 To Remove The Main PCB (A0702/01)

Caution: Observe anti static precautions when handling the PCB.

1. To remove the main PCB A0702/01 loosen the two retaining washers (A.)

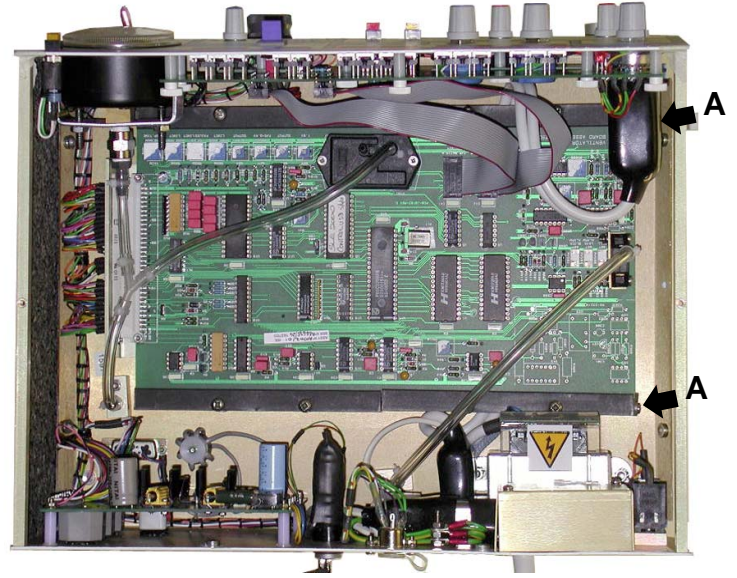

2. Cut the cable tie connecting the fresh gas tube to PTR1 (B)
3. Pull the fresh gas tube from the transducer.

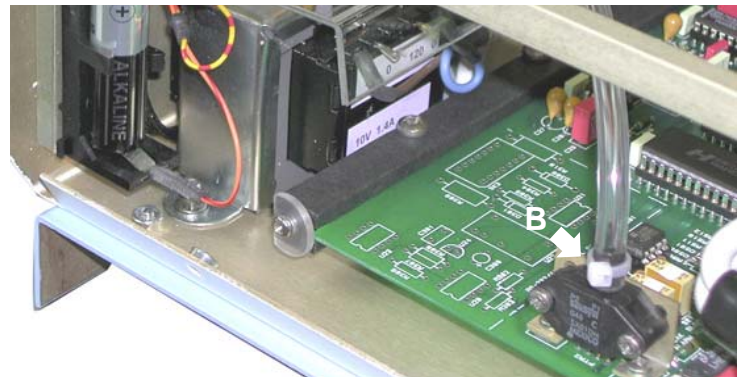

4. Disconnect the two ribbon cables (C) from the PCB
5. Cut the cable tie connecting the Proximal Airway Tube to PTR1 (D)
6. Pull the Proximal Airway Tube from the transducer.
7. The PCB can now be removed.

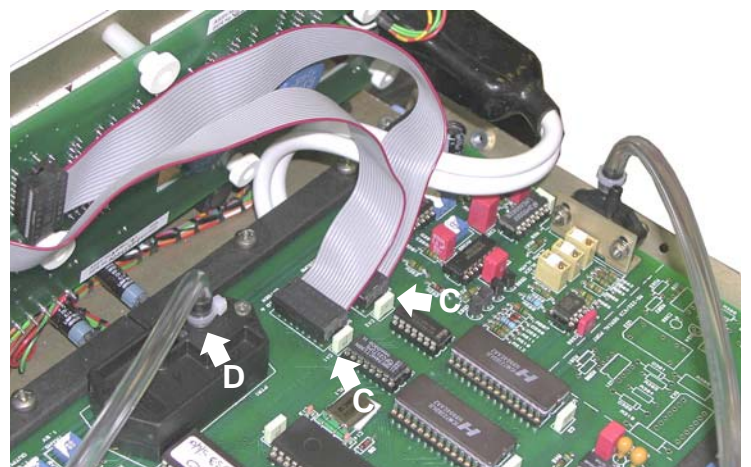

8.3 To Separate The Two Modules

1. Invert ventilator to gain access to the base of the pneumatic module.
2. Remove the four screws (A).

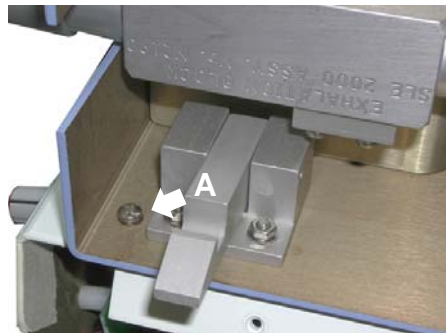
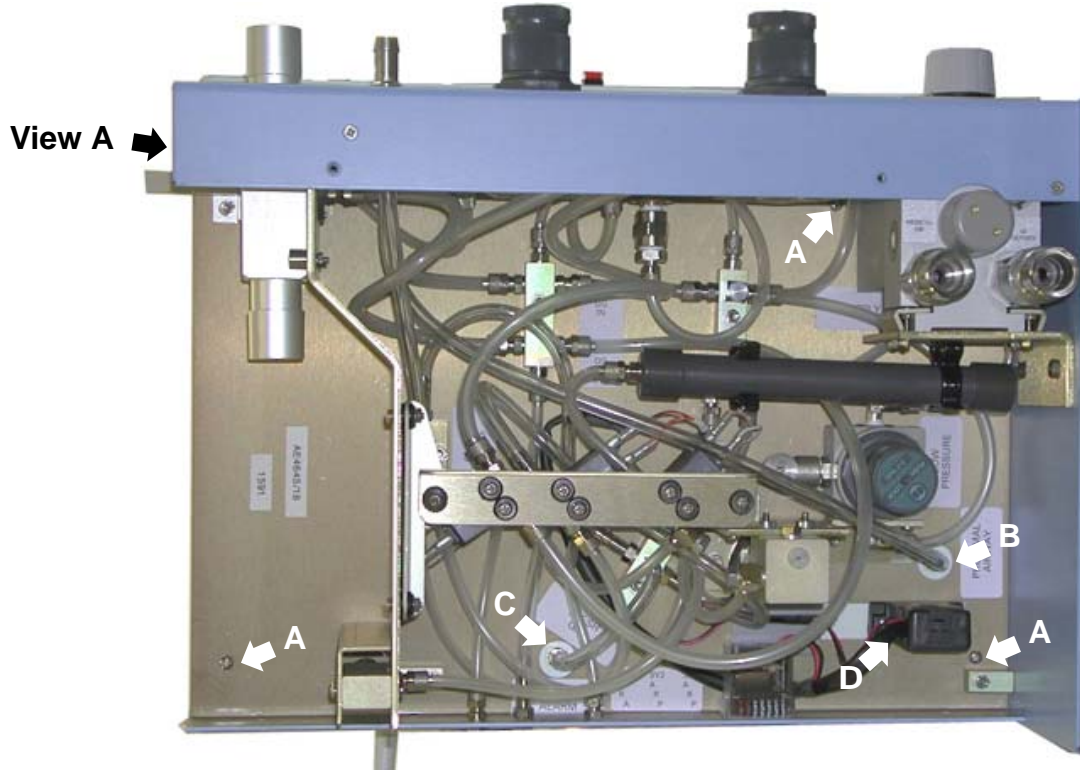

View A

3. Remove proximal airway pressure tube connection (B).
4. Remove Fresh gas monitoring tube connection (C).
5. Release both locking screws and disconnect the 15 way plug (D).

It is now possible to separate the pneumatic module from the electronic chassis.

8.4 Removal Of The Oxygen Blender

1. Gain access to the pneumatic module.
2. Remove the flowmeter outlet (A) (if fitted).

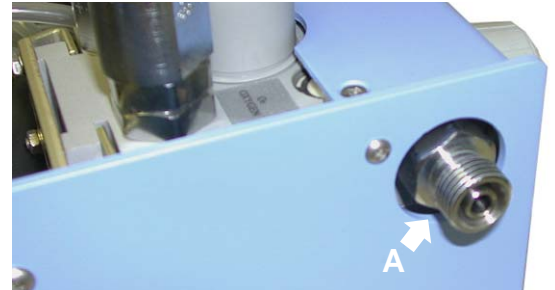

3. Unclip the large volume chamber (B) and move it to one side. It is not necessary to disconnect the tubing connector.

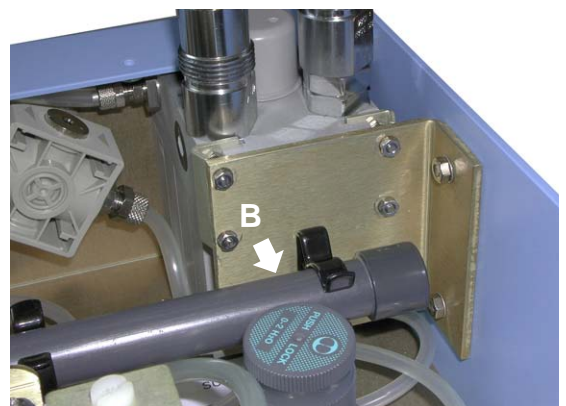

4. Undo and remove the two nuts, screws and washers (C) from the side panel.

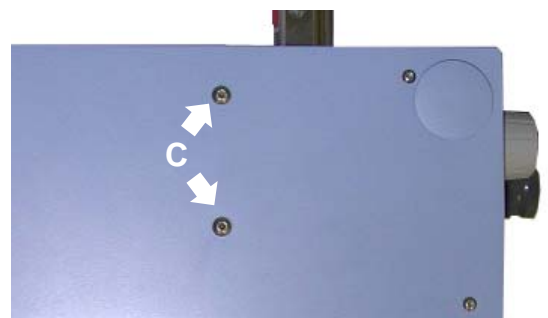

5. It is now possible to manoeuvre the Oxygen blender out of the front panel aperture a sufficient distance to enable the main supply connector (D) to be uncoupled.

6. It will now be possible to completely remove blender from module.

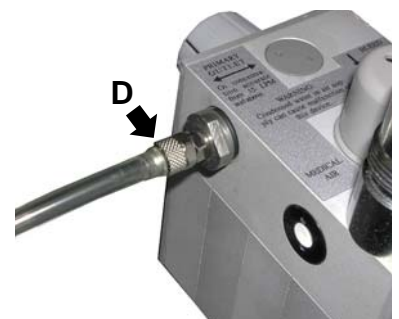

To install new blender repeat the above process in reverse order.

8.5 Removal of the Oxygen cell

Firstly gain access to the pneumatic module

8.5.1 Oxygen Cell Mounting

The SLE 2000 ventilator has two methods of mounting the Oxygen cell. The first method the oxygen cell is trapped between the manifold and a foam pad, Photograph A.

The second the oxygen cell is screwed directly into the manifold, Photograph B.



Photograph A

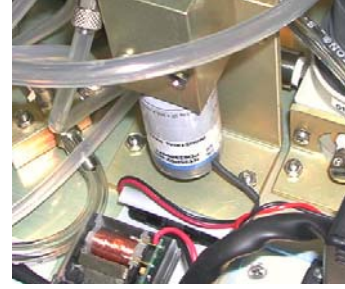

Photograph B

8.5.1.1 Method A for Trapped cell.

1. Disconnect the cell connector (A).

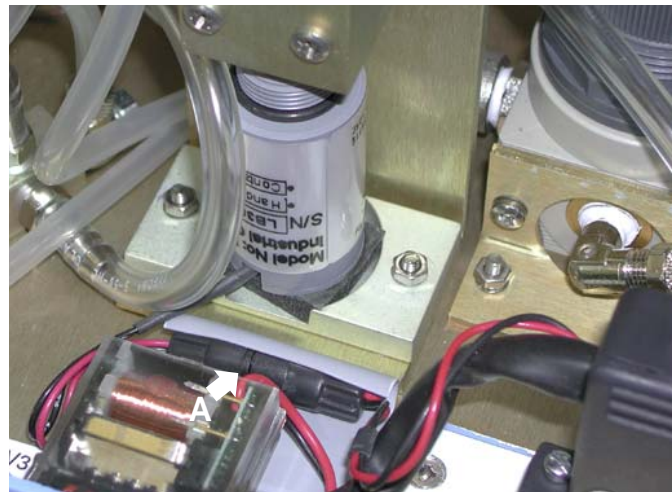

2. Remove the two screws (B) retaining the manifold and lift it clear.

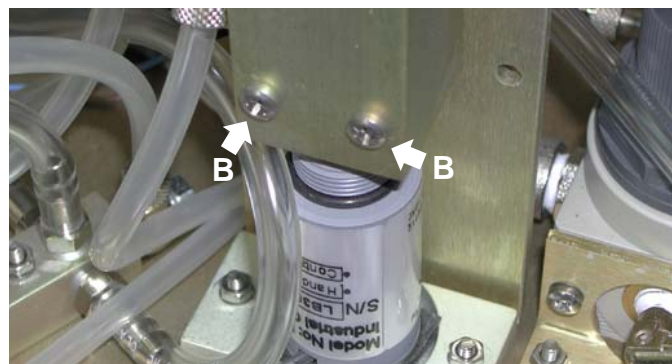

3. Remove old foam retaining pad (C) from mounting base (if applicable)
4. Assembly is the reversal of removal.
5. Replace cell (Part No. N2191) and reconnect the electrical connector.



6. Ensure that the foam rubber pad is fitted between the cell and the mounting base and that the gas seal "O" ring is fitted to the manifold. After refitting, recalibrate the cell.

8.5.1.2 Method B for Screw in cell.

1. Disconnect the cell connector (D).



2. Remove the two screws (E) retaining the manifold and lift it clear.

3. Unscrew the old cell.

4. Assembly is the reversal of removal.

5. Screw in the new cell (Part No. N2191) and reconnect the electrical connector.

After refitting, recalibrate the cell.

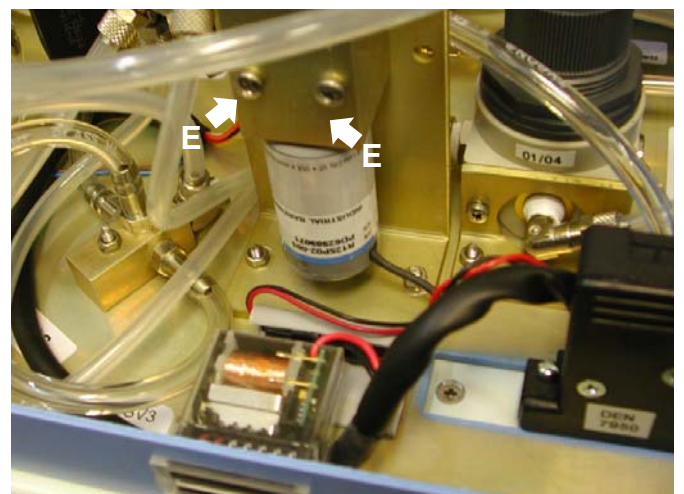



This page is intentionally blank.

Maintenance



9. Maintenance

9.1 Cleaning, Disinfection and Sterilization

All cleaning, disinfection and sterilizing should be carried out under the direction of the appropriate hospital authority.

DO NOT allow moisture to enter the electronic module or its electrical sockets. Electronic malfunction may result.

DO NOT steam autoclave the SLE 2000 or otherwise subject it to temperatures above 62°C.

DO NOT immerse any part of the SLE 2000 in any liquid, with the exception of the expiratory exhalation block (SLE part No N2190).

9.1.1 Preparation of a new ventilator

Remove all transit packaging. Inspect the fresh gas port and proximal airway port for any packing material. (Retain packaging for future use as the ventilator must be returned in its original box).

Remove the protective film from the LCD screen.

Clean, disinfect and sterilize in accordance with the instructions in section 9.1.2 .

Remove the inlet air and O₂ gas port caps. (Retain for future use).

9.1.2 Cleaning and disinfection of an in-service ventilator

The table 1 outlines the areas of the ventilator which can be uniquely cleaned, disinfected and sterilized.

Before cleaning or disinfecting the exterior of the ventilator the following tasks should be performed:

- The mains cable should be disconnected from the mains supply.
- Remove the patient circuit and bacterial filters. Discard any single use items as per appropriate hospital authority guidelines. Reusable items should be processed as per appropriate hospital authority guidelines and the manufacturers instructions.
- Disconnect the gas supplies from the wall outlets.
- Disconnect the Oxygen and Air hoses from the ventilator and cap the inlet ports.

- Lift up lever (A) on side of ventilator and lower side flap.
- Remove the silencer (B) by pulling it through the hole at the rear.
- Remove the exhalation block (C) by firstly taking hold of the block and then pulling it out towards you without the need for undue force.

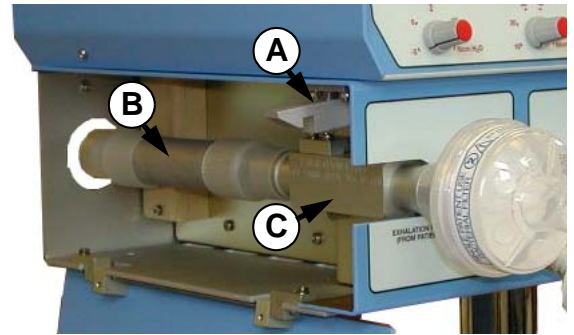

Refitting the silencer and exhalation block is the reversal of removal. **Do not force the exhalation block into place.**

9.1.3 Cleaning, Disinfection & Sterilization chart

Item	Clean	Disinfect	Sterilize
Ventilator	Yes	Yes	
Silencer			Yes
Exhalation block	Yes	Yes	Yes

Table 1

Warnings (General): Do not insert any object (such as a needle) in to the gas ports. This action will result in damage to the port. If the user believes there is a foreign object in a gas port, please refer the ventilator to qualified service personnel for inspection and repair.

Note: The silencer should be autoclaved only. If the silencer is found to have visual contamination internally, discard and replace with a new silencer.

9.1.4 Cleaning method

Note: Cleaning is an essential prerequisite to disinfection and sterilization.

Ventilator. For cleaning use three clean, disposable, absorbent, non-shedding cloths. Wipe clean with the first cloth using a hand hot water/mild general purpose detergent solution (as prescribed by the appropriate hospital authority). Do not overload the cloth with liquid. Remove the water/mild general purpose detergent solution with the second cloth using water only. Do not overload the cloth with liquid. Wipe dry with the remaining cloth. Care should be taken to ensure that the ventilator gas jets in the ports are not blocked by any debris.

Exhalation block. The exhalation block can be immersed and agitated in the detergent solution. Do not insert any objects into the exhalation block. Rinse the exhalation block in clean water, it must be allowed to dry thoroughly before sterilization.

Warning: Ensure that the detergent solution or water does not enter the unit or the exhalation block gas ports on the side of the machine.



9.1.5 Disinfection method

Note: Alcohols such as 70% isopropanol have a good activity against bacteria and viruses. They should only be used after all visible surface dirt has been removed from the area to be disinfected.

Ventilator. For disinfection use two clean, disposable, absorbent, non-shedding cloths. Wipe clean with the first cloth using Alcohol (70% isopropanol). Wipe dry with the remaining cloth.

Exhalation block. The exhalation block can be immersed in Alcohol (70% isopropanol). The exhalation block must be allowed to dry thoroughly before sterilization.

9.1.6 Sterilization method

The silencer SLE part N° N2186 and exhalation block SLE part N° N2190 must be sterilized between use on patients. The ventilator cannot be sterilized.

The exhalation block must be cleaned as an essential prerequisite to sterilization.

Autoclave with pure dry saturated steam at:

134°C (277°F) (Allowable variation of temperature of +3°C) at 220kPa (32psi) with a minimum holding time of 3 minutes

or

121°C (248°F) (Allowable variation of temperature of +3°C) at 96kPa (14.1psi) with a minimum holding time of 15 minutes.

There is no limit on number of autoclave cycles for the exhalation block.

The silencer can be autoclaved up to 20 times. The body of the silencer should be marked after each autoclave cycle with a high temperature, water proof, permanent marker to indicate number of sterilization cycles completed.

9.2 Filter Systems



It is recommended that bacteria filters are fitted in the fresh gas supply and on the patient side of the exhalation block.

The filters reduce the possibility of infection to the patient and contamination of the ventilator from secretions or fluids in the breathing circuits that could accidentally enter the ventilator's gas ports.

It is recommended that a silencer be fitted on the exhaust side of the exhalation block, this helps to reduce the noise level of the system.

The SLE2000 can be used without bacterial filters in place, but the user must take extra care in not

allowing secretions or fluids to enter the ventilator's gas ports.

9.2.1 Bacterial filter, SLE Part N°:N2029 (Autoclavable)

This autoclavable bacterial filter is fitted into the humidifier supply line and has to be fitted in accordance with the indicator arrow embossed on the surface of the filter.

Do not immerse the filter in any liquid.

Autoclave with pure dry saturated steam at:

134°C (277°F) (Allowable variation of temperature of +3°C) at 220kPa (32psi) with a minimum holding time of 3 minutes

or

121°C (248°F) (Allowable variation of temperature of +3°C) at 96kPa (14.1psi) with a minimum holding time of 15 minutes.

The filter can be autoclaved a maximum of 25 times within its anticipated service life of 12 months. For other makes of bacterial filter please refer to manufacturer's instructions.

9.3 Bacterial filter, SLE Part N°:N2587 (Single use)

This single use bacterial filter is fitted onto the exhalation block outlet. This filter should be disposed of in accordance with local hospital authority guidelines. A new filter should be used for every new patient.

9.3.1 Precautions when using bacterial filter N2587

The user should be aware that any occlusion of the filter increases the resistance to airflow, resulting in increased or erratic airway pressures. Airway pressures should be monitored during use and the filter changed if found to be contaminated in any way. When using humidification the filter should be checked regularly for signs of water build up which could cause occlusion.



9.4 Monthly Operational Checks

9.4.1 Battery condition and LED display test.

Switch unit to CPAP position. All alarms should sound for two seconds. All digital displays should show a sequence of digits from 0 to 9 and all alarm LED's (except the Block LED) will be on for the duration of this test.

9.4.2 Air and Oxygen Supply Failure Alarm test.

With the FIO₂ blender set to 60% remove in turn both air and oxygen supplies. Check that in each case the alarm sounds, and on replacement the alarm cancels.

9.4.3 Condition of O₂ Cell

Set blender to 21% and observe that displayed FIO₂ is 21%. Set blender to 100% and observe that displayed FIO₂ is 100%. Adjust if necessary. If error prior to adjustment exceeds 10% replace O₂ cell.

9.4.4 Proximal Airway Pressure Gauge Accuracy

Set ventilator to CMV; 60 BPM: 0.5 sec. inspiration time. Adjust PIP pressure to 50 cmH₂O digitally displayed. Compare digital pressure display with mechanical gauge. Error should not exceed 3%.

9.4.5 Inspiratory Nozzle

Turn the inspiratory pressure regulator fully clockwise, adjust PIP alarm fully clockwise. Set ventilator to CMV: 60BPM: 0.5 sec inspiration time. Peak inspiration pressure should be greater than 60 cmH₂O.

9.5 Preventative Maintenance

Preventative maintenance should be completed at a maximum of every 5000 hours operation or at 6 monthly intervals. This maintenance is intended to be carried out in the hospital.

Preventative Maintenance will include :

- Visual inspection and cleaning of all exterior surfaces, controls, attachments and accessories.
- Removing the covers and cleaning all dust from the interior of the unit.
- Visual inspection of all tubing, electrical wiring, connectors, crimps, screws, nuts, hardware and checking the general condition of all other internal components and assemblies.
- Inspection of the mains failure battery holder for corrosion and replacement of the battery.
- Pneumatic and electronic testing and where necessary calibration of ventilator.
- Replacement of orifice block 'O' ring.
- Replacement of battery.

9.6 Overhaul

Overhaul should be carried out at a maximum of 10,000 hours operation or every two years of service which ever is sooner. This overhaul will be performed by an SLE trained hospital engineer or an SLE service engineer.

In addition to the checks and items performed during the preventative maintenance, an overhaul will include :

- Replacement of oxygen monitor cell,
- Replacement of oxygen blender,
- Replacement of main solenoid SV1,
- Replacement of PIP and CPAP regulators
- Replacement of orifice block 'O' ring.
- Replacement of battery.
- Checking operation and general condition and replacing where necessary the following components :

Solenoid valves SV2 and SV3.

Tubing and connectors

Battery holder

Alarm sounders

Mode, wave shape, frequency range and pressure range switches.

Pressure relief valves.

SLE offer an exchange service for the pneumatic module.



9.6.1 Service Parts List

Preventative Maintenance 5,000 Hour

Item	Part Number
'O' Ring	N2042
Battery	MN1500

Overhaul 10,000 Hour Service or 2 Years

Item	Part Number
Blender	N2185 EX
Oxygen Cell	N2191
Solenoid Valve SV1-SV3	N2195/05
0-4 Bar regulator	N2181
0-2 Bar regulator	N2182
'O' Ring	N2042
Battery	MN1500



**Setup and
Calibration**

10. Test Equipment Required

The following test equipment is required to perform the calibration and set up procedures as described in See "Electronic Module Calibration Procedure" on page 41.

Electronic: Digital multimeter (Fluke 77 or similar).
Twin beam oscilloscope (Hameg HM205 or similar).

Pneumatic: Multi-range Pressure and Flow analyser (Timeter RT200 or similar).
O₂ Analyser (Servomex 570A or similar)

Miscellaneous: Connectors and tubing.
Metric hexagonal keys 3mm, 2.5mm, 2mm.
2mL syringe.
10mL syringe.
Variable Flow Restrictor

Electronic Module Dummy Load (optional):

This is a test load which plugs into the 15 way 'D' connector on the base of the electronic module. It emulates the resistive loads of the pneumatic module solenoids thus allowing the electronic unit to be tested in isolation.

details as follows;

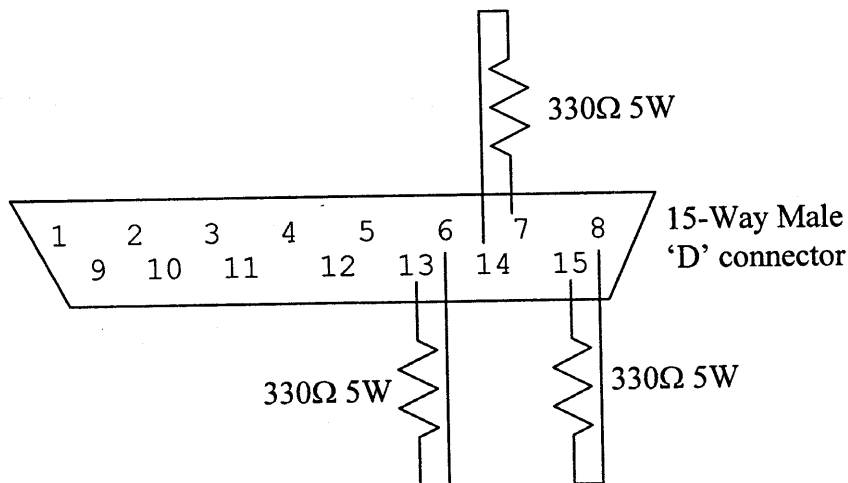

11. Electronic Module

The SLE 2000 is arranged in two modules. The Electronic Module is the upper of the two modules which contains all of the electronic controls and displays.

11.1 Description of Operation

Refer to circuit diagram "Ventilator CPU Board CD/A0702/01 Issue 6" on page 77. The processor board comprises the main microprocessor and ventilator control circuitry, the display drivers, the patient trigger system, and pneumatic alarm circuitry

The processor (U14) is an 80C31 running at 11.0592MHz. It is an 8 bit processor, employing time multiplexed address and data operations. Software is provided by the EPROM (U6).

Analogue input parameters from panel control settings (BPM rate, inspiration time, CPAP alarm threshold, PIP alarm threshold) are converted to digital 8 bit words by the ADC (U18) which scans each input in turn. Open circuit input fault conditions are detected by software and pull-up resistor array (RU3). Switched input parameters (mode, Range, Reset, Mute, Pressure display Mode) are scanned by (U12).

Confirmation of correct solenoid valve energisation voltages is fed to (U14/14) by potential divider R34, R32 and clamp D3.

Supply voltage supervisor (U7) will attempt to reset the processor (U14/9) should the logic supply voltage of 5.12V dc fall below 4.8V dc. It also holds the processor reset for a 2 second test period on power up.

Unlatched audible alarm BZ1 is activated when any analogue input is detected to be outside the predetermined range. It is driven from (U14/4) via (U13) to PLB 7a. In conjunction with BZ1 there are three visual latched alarms (CPAP Fail, High Pressure, Cycled Failed); all are processor activated from outputs (U14/2,6,1) which are buffered by (U10) and connected to PLB 14a, 3b, and 14b respectively. The buffered high pressure alarm output also de-energises the dump valve solenoid via PLB20b.

Trigger back-up and alarm mute indication LED's are driven by the processor from (U14/5) and (U14/7) via buffer (U10) and are connected to PLB3a and PLB 15b.

The main PIP solenoid valve and the waveshape solenoid valve are driven from (U14/8 via buffer (U10) and MOS driver Q4.

The LED Board A0701/01 (See "LED Circuit Board Diagram CD/A0701/01" on page 66.) accommodates the max., mean, min. LED buffer (U400) and LED's CPAP, Cycle Fail, High Pressure, Block, Leak and Trigger. (U1) and (U2) are 7 segment display drivers.



There is a supervisory watchdog alarm system which consists of (U8) and BZ2. This monitors a train of 10ms pulses from (U14/3) to confirm the correct running of the software. A disruption of these pulses will activate a latched audible alarm BZ2. In addition, reset pulses from (U7/6) to (U14/9) will attempt to restart the software until the 10ms watchdog pulses are restored.

The Mains Failure Alarm relay RL1 is energised from the 5.12 volt logic supply and holds pins 1 and 14 open. Should the relay de-energise contacts 1 and 14 will close, and a battery powered alarm will be activated via connections PLB 18a and PLB 20a.

On power-up, a short test period is initialised. Time constant R2, C5 via (U4) forward biases (Q1) for approx. 2 seconds, therefore shorting PLB 18a and PLB 20a and operating the battery alarm.

PTR1 is connected to the proximal airway pressure line. (U13/1, 2, 3) and associated components form an 8V dc voltage regulator. (U13/8, 9, 10) process the analogue voltage output from PTR1 into the range 1-3.4V corresponding to pressures of 0-40 cmH₂O prior to A to D conversion. (U13/5, 6, 7) process the analogue voltage output to the range 1-6V dc for an input of 0-50 cmH₂O for an analogue output signal.

Fresh gas failure pressure transducer PTR2 monitors the fresh gas supply pressure transducer PTR1 monitors the fresh gas supply pressure and activates the audible alarm BZ3 and also drives the leak alarm LED should the pressure fall below 17.5 cmH₂O. If the pressure rises above 80 cmH₂O then the block LED is operated and the audible alarm will activate.

11.2 Electronic Module Calibration Procedure

Note: If electronic module is being set up without the pneumatic module attached, then a dummy load must be connected to 15 way 'D' connector on base of module as a substitute for the solenoid valves. (See "Test Equipment Required" on page 38.)

11.2.1 Preliminary Checks and Adjustments

Remove printed circuit board A702 from PLB connector.

Check that PLB 1b is connected to the chassis earth terminal.

Connect -ve probe of DVM to PLB 1b (0V).

Check the voltage on PLB 32b is approx. 5.12V dc \pm 0.01V.

Check the voltage on PLB 22b is approx. +12-14 V dc.

Check the voltage on PLB 6b is approx. +55V dc \pm 5V.

Power down unit under test and replace PCB A702 into its socket.

Power up unit and set mode to CPAP.

Monitor PLB 32b adjust RV 102 on A703 to give 5.12V dc \pm 10mV

Monitor voltage at cathode of D5, check that voltage is 55V dc \pm 5V.

Set inspiration control to 3 seconds. With wave shape switch set to square position, press manual breath button, and confirm that voltage falls to 30V \pm 5Vdc.

With the pressure wave switch set to taper position, press manual breath button, and confirm that voltage falls to 25V \pm 3V dc.

11.2.2 System watchdog

Note: This control is factory set and should not normally require adjustment on service.

Monitor (U3) pin 11. By adjusting RV10 ascertain the two points where the voltage falls from 5.12V to 0V, then set RV10 to midway between these positions, and ensure that the voltage on (U3) pin 11 is a continuous +5.12V.

11.2.3 Pressure Transducer PTR1 to ADC

With PTR1 open to atmosphere monitor the DC voltage on pin 26 (U18). Adjust RV2 to set voltage to 1V \pm 10mV. Using a suitable accurate reference apply a pressure of 40 cmH₂O \pm 0.1 cmH₂O to PTR 1,P2. Adjust RV5 to give 3.4V dc \pm 10mV. Repeat this procedure until both voltages are correct to within \pm 10mV for their respective pressures.

11.2.4 Pressure Transducer Buffered Output

With PTR1 open to atmosphere, monitor voltage on PLB 23b and adjust RV3 to give 1V dc \pm 10mV. Then with a suitably accurate pressure source apply a pressure of 50 cmH₂O \pm 0.1 cmH₂O to PTR1 P2, then adjust RV4 to 6.0V dc \pm 10mV. Repeat this procedure until both voltages are accurate to within \pm 10mV for their respective pressures.



11.2.5 CPAP Alarm Set Point Control

Monitor voltage on (U18) pin 27.

With the CPAP control fully ACW slowly rotate control until voltage just exceeds 0V and not more than 50mV.

Then release the collet on the control knob and re-position it so that the pointer points to -5 cmH₂O. Tighten collet and rotate control to 15 cmH₂O and adjust RV9 to 1.2V dc \pm 10mV.

11.2.6 PIP Control

Monitor voltage on (U18) Pin 2. With control turned fully ACW rotate clockwise and note position where voltage = 0.3V \pm 5mV. Loosen collet on knob and reposition to point to 10 cmH₂O. Retighten collet. Adjust control pointer to 50 cmH₂O and adjust RV7 to 2.7V \pm 10mV. Turn knob back to 10 cmH₂O and check voltage is 0.3V. Repeat adjustment if necessary.

11.2.7 Inspiration Time

Rotate Inspiration time control knob fully clockwise and adjust RV6 to give a digital display of 3.0 seconds.

11.2.8 Alarm Volume

Note: This control is factory set and should not normally require adjustment on service.

Check that adjustment to RV1 varies the audible alarm volume, then set RV1 to middle of its travel. Verify that a suitable alarm volume is present.

11.2.9 Fresh Gas Block and leak Alarm

Remove gas supplies from ventilator and connect digital voltmeter between pins 2 and 4 of PTR2. Adjust RV500 to give voltage of $0V \pm 0.1mV$.

With Air and O₂ connected to the pneumatic module and the blender set to 21% monitor the fresh gas flow and confirm that flow is $5LPM \pm 0.25LPM$. With a suitable flow control valve create a pressure in the fresh gas line of $17.5 \pm 0.5 \text{ cmH}_2\text{O}$. Adjust RV501 so that the leak alarm and LED just trip on.

Close the flow control valve until pressure in the line increases to $80 \pm 1 \text{ cmH}_2\text{O}$ and adjust RV502 until the block alarm and LED just trip on.

11.2.10 FIO₂ Digital Display

With both Air and O₂ supplies at approximately 4 bar pressure, monitor gas at the fresh gas outlet with an Oxygen analyser with an accuracy 1% or better. Set O₂ blender to 100% oxygen. Remove air supply and note reading on analyser. Then adjust the calibration potentiometer on rear panel of electronic module so that the FIO₂ digital display agrees with the analyser reading to within $\pm 0.5\%$.

Return Air supply.

Note: This following control is factory set and should not normally require adjustment on service.

Set blender control to 21%, then remove oxygen supply and adjust RV101 on PCB A703 until digital display shows 21%. Repeat both at 21% and 100% settings until both readings are better than 1%.

Check for linearity at all 10% points on the front panel FIO₂ scale and ensure accuracy checked against analyser is better than 3% on the blender and 1% on the digital display.

11.2.11 Airway Trigger Calibration

Using a complete standard patient circuit (N2188) with a humidifier chamber and test lung fitted, perform the following.

- 1) To set the expiratory time window, with a dual beam oscilloscope connect CH1 to pin 2 (U200) and ground, with trace inverted, CH2 to pin 4 (U200) ; (timebase 100ms/cm; sensitivity 2V/cm); set ventilator to CMV, 60 BPM, 0.5s Insp. time. This will produce two positive going similar waveforms. Adjust RV200 such that the interval between the two leading edges is $200ms \pm 10ms$.
- 2) Select a BPM rate of 1 BPM and an inspiration time of 0.5 seconds, set PIP to $30 \text{ cmH}_2\text{O}$ and with the CPAP regulator turned off completely and the alarm parameters set CPAP = $0 \text{ cmH}_2\text{O}$, PIP = $30 \text{ cmH}_2\text{O}$.



-
- 3) Switch ventilator into PTV Mode and adjust PTV threshold potentiometer fully clockwise.
 - 4) Fit a 2 ml syringe into the tracheal port of the ET manifold.
 - 5) Slowly draw 2 ml of air from the tracheal port at an approximate rate of 2ml in 0.5 second.
 - 6) If ventilator fails to trigger or falsely triggers, it will be necessary to adjust RV202 until the desired response is achieved.
 - 7) Remove 2ml syringe and replace with 10ml syringe.
 - 8) Turn PTV threshold fully anti-clockwise, draw 10ml over 0.5 seconds ensuring that the ventilator triggers on this inspiratory effort.

11.3 SLE 2000 Electrical Troubleshooting Chart

PROBLEM	POSSIBLE CAUSE	REMEDY
1. When unit is switched ON, POWER light is not illuminated, battery fail alarm sounds continuously.	a) No A.C power b) No A.C power to transformer c) No secondary voltages (45V rms & 10V rms) d) No DC voltages from PSU PCB (60V, 12V, & 5.12V) e) Fault on processor PCB	Check wall sockets. Check: fuses mains filter on-off switch Check for short circuits, otherwise change transformer Check for short circuits, otherwise replace A0703/01 PCB and recalibrate. Replace A0702/01 pcb and recalibrate
2. SYSTEM FAIL alarm will not cancel	Processor pcb faulty	Replace A0702/01 PCB and recalibrate
3. HELP message displayed on digital readout	Open circuit analogue inputs to processor	Check operation of potentiometers and wiring harness connections
4. SOL message displayed on digital readout	a) Faulty or open circuit solenoid b) faulty wave shape switch c) Faulty BPM range switch d) Faulty power supply e) Harness fault	Check operation of solenoid and replace if necessary Replace Replace Refer to 1d Refer to circuit diagram and check integrity of harness connections
5. Ventilator powers up, but does not cycle in CMV mode and no audible or visual alarms.	Check for 5.12V dc on pin PLB 32b of PCB A0702/01	If voltage absent refer to 1d



12. Pneumatic Module

12.1 Description of Operation

Air and oxygen supplies are connected directly to the blender. The output of the blender is supplied via panel mounted regulator REG.1 (inspiratory pressure) and solenoid valve SV1 to the inspiratory nozzle in the exhalation block. It is also connected to the normally closed port of the wave shape solenoid (SV3) and the large volume chamber.

In inspiration mode the valve SV1 opens and allows a flow of blended gas into the patient circuit via the inspiratory nozzle. This flow opposes the constant fresh gas flow and creates an inspiratory pressure.

The function of the large volume chamber and valve SV3 is to delay this flow of gas during the inspiratory phase when the pressure wave switch is set to taper. On expiration SV3 de-energises and dumps to atmosphere so that the expiratory airway pressure falls rapidly as in square mode.

REG2 (CPAP) is also supplied from the oxygen blender. This front panel mounted regulator controls the flow of blended gas from the CPAP nozzle in the exhalation tube. This gas being a constant flow in opposition to the fresh gas flow creates a CPAP/PEEP pressure in the patient circuit.

NOTE any changes of CPAP pressure will also change the peak inspiratory pressure. This is arranged so that the tidal volume is always constant and unaffected by changes in CPAP.

REG3 is an internal regulator which regulates the blended gas to a working pressure of 10 PSI. NV1 is adjusted to set a 5 LPM blended gas flow into the fresh gas port on the front panel when SV2 is activated (eg the ventilator is powered up). This flow passes through valve SV2 (fresh gas dump solenoid) which will dump the fresh gas should the patient circuit pressure reach the high pressure alarm threshold. When SV2 is deactivated (ventilator off or fresh gas dumped) then the fresh gas flow is 1LPM. This residual flow is to ensure correct operation of the humidifier.

RV2 is an additional relief valve which activates at fresh gas pressures above 140cmH₂O.

NV2 sets a 7LPM bleed to atmosphere. This flow combined with the 5LPM fresh gas flow ensures that the oxygen blender has the 12LPM flow through it required to maintain its accuracy. This bleed is also fed to the oxygen monitoring cell, whose output is connected to the digital F10₂ display circuitry in the electronics module.

The fresh gas transducer PTR2 is mounted in the electronic module and monitors the patient airway pressure. The SLE 2000 because of its unique principle of operation will ventilate the patient without the fresh gas supply. In order to ensure that the patient is always being supplied with fresh humidified gas, a restrictor is fitted in the patient fresh gas tubing close to inspiratory port of the ET connector. The restrictor maintains a circuit pressure of approximately 20 cmH₂O. This pressure is monitored by PTR2 to be within the range 17.5-80 cmH₂O. A leak or a blockage condition in this circuit causing the pressure to be outside of these limits will activate the respective alarms. A pressure above 80 cmH₂O will cause the block alarm and LED to operate and dump the fresh gas via SV2. If the pressure falls below 17.5 cmH₂O then the leak alarm and LED will be activated.

12.2 Fresh Gas System

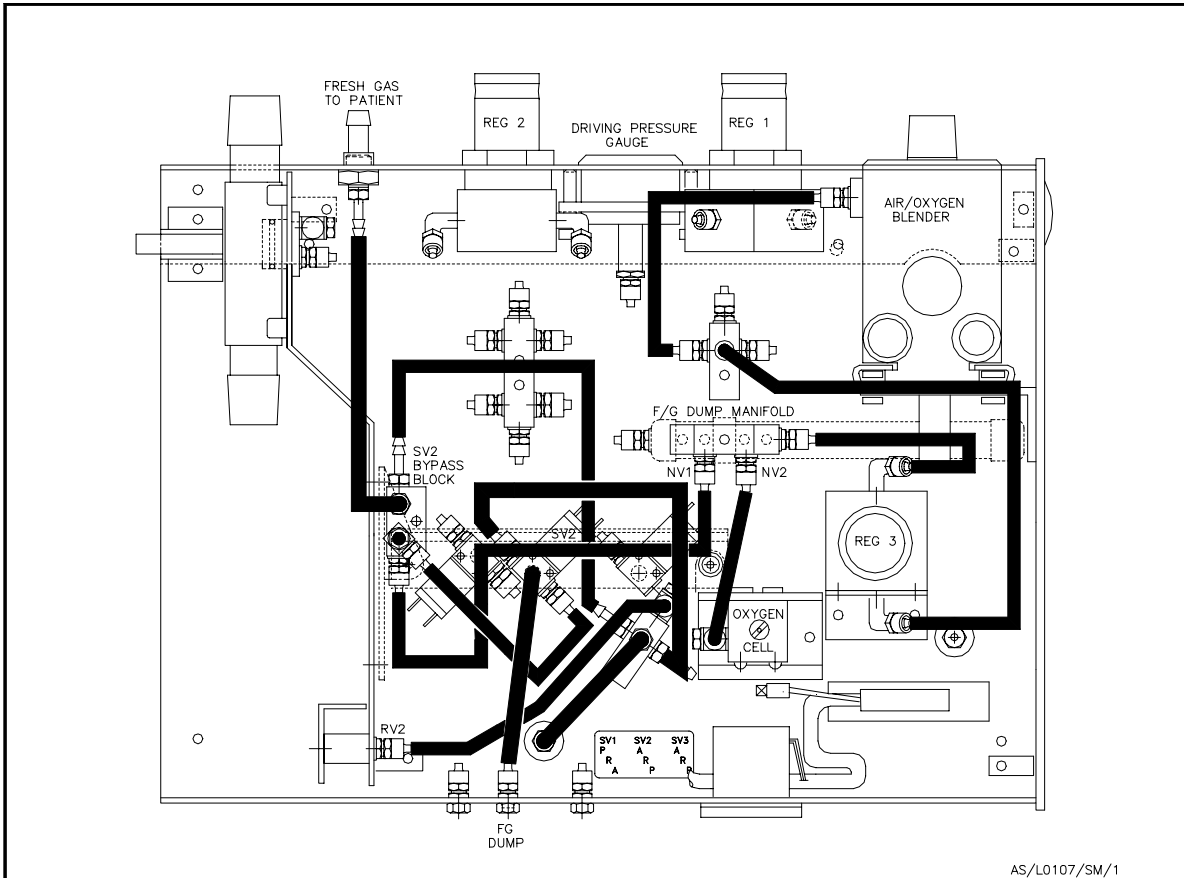

Gas from the AIR/OXYGEN Blender is supplied to the preset regulator REG3 via the supply manifold. The output of REG3 is set to 10PSI and is fed to two flow valves.

NV2, which is set to a flow of 7LPM and dumps to atmosphere via the O₂ cell.

NV1, which is preset to 5LPM and supplies the fresh gas to the patient circuit via SV2 (high pressure dump solenoid) and a circuit preset pressure relief valve RV2.

The SV2 bypass provides a continuous flow of 1LPM through the humidifier in the event of a high pressure dump.

12.3 CPAP System

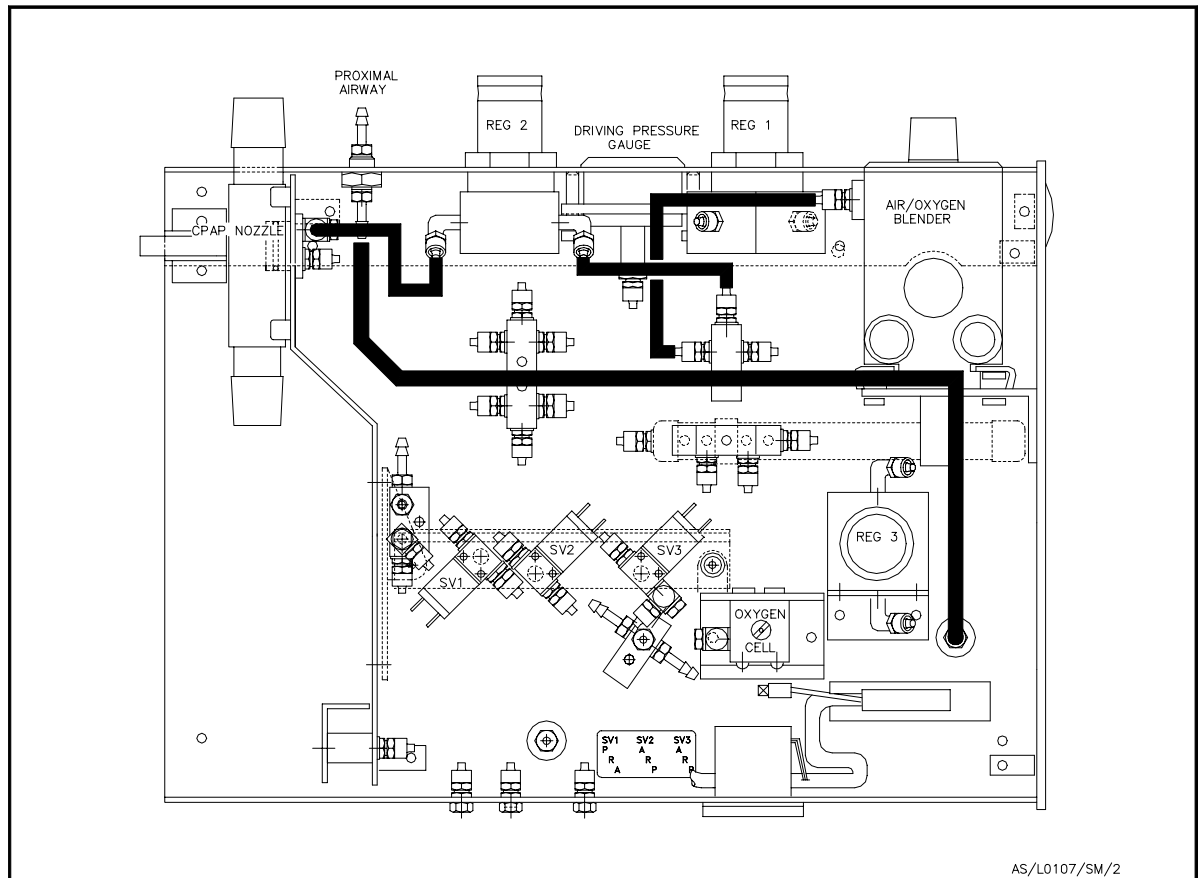

AS/L0107/SM/2

Gas from AIR/OXYGEN Blender is supplied to the CPAP pressure regulator REG2 via the supply manifold. The output pressure of REG2 is fed to the CPAP nozzle in the expiratory manifold, and into the expiratory limb of the patient circuit to create the circuit CPAP pressure.

12.4 Inspiratory System

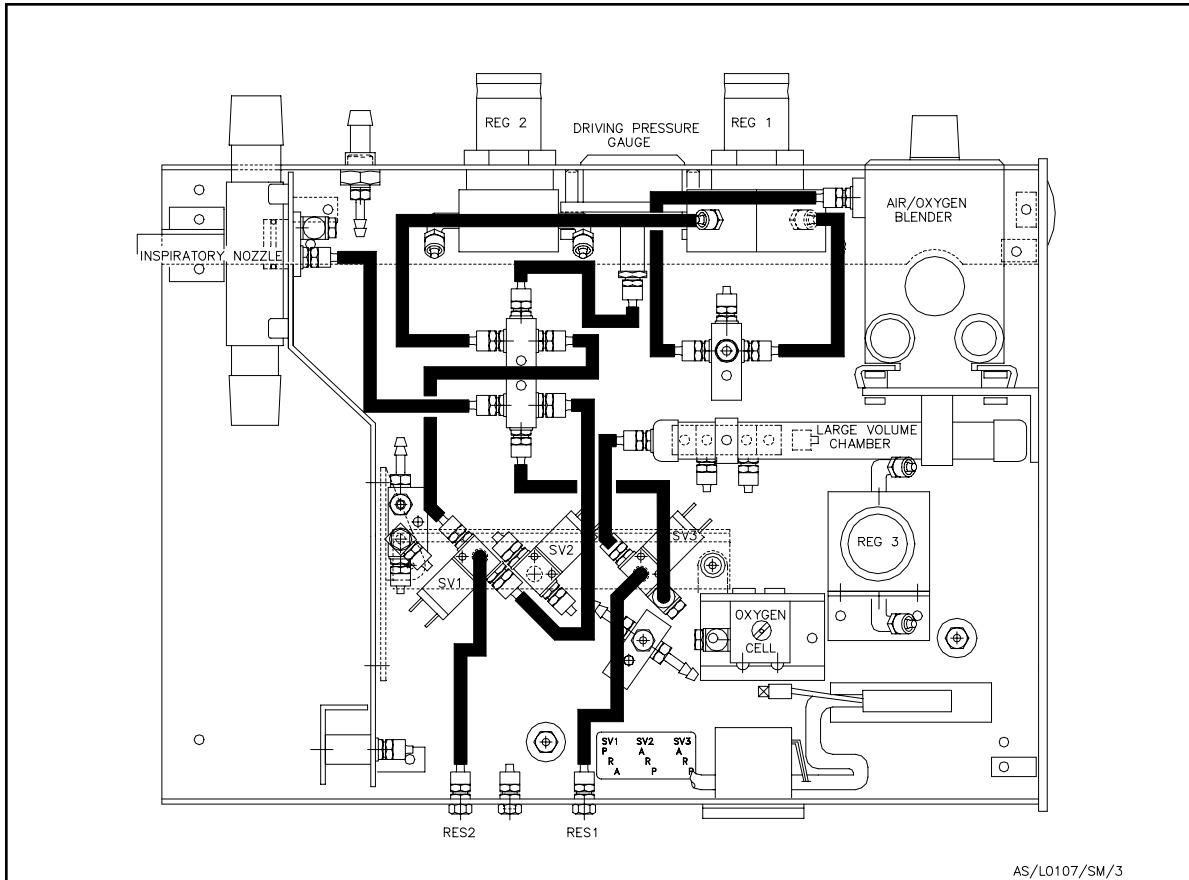

Gas from the AIR/OXYGEN Blender is supplied to the user adjustable PIP regulator REG1 through the supply manifold. The output pressure of REG1 is supplied to the inspiratory nozzle via the solenoid valve SV1 which controls the breathing rate. If the pressure wave switch is in the taper position then SV3 is energised and the inspiratory flow enters the large volume chamber before reaching the inspiratory nozzle, thus lengthening the pressure rise time.

12.5 Pneumatic Calibration Procedure

Connect ventilator to air and oxygen supplies with standard patient circuit and with the electronic module switched to CPAP mode. Set PIP control fully clockwise and adjust blender to 21% Oxygen.

NOTE:

- a) Monitor the Fresh Gas Pressure regulator output using the test point provided and adjust output of regulator Reg.3 to 10 PSI \pm 0.5 PSI.
- b) Monitor minimum flow valve at outlet on base of machine. Ensure that the oxygen cell is fitted securely and there are no leaks at its seating.
Adjust and set dump valve NV2 to 7 LPM \pm 0.25 LPM.
- c) Monitor flow from the fresh gas outlet port on the front panel, and adjust flow valve NV1 to give a flow at this port of 5 LPM \pm 0.25 LPM.
- d) With the Mode switch in the OFF position, check that the Fresh Gas flow at the Fresh Gas port is 0.8 to 1.2 LPM.

Repeat adjustments (a) to (c) until all measurements are within their respective tolerances.

Monitor the proximal airway pressure with a standard test manometer. With the P.I.P. regulator fully anti-clockwise, turn CPAP regulator fully clockwise and ensure that CPAP pressure is greater than 15 cmH₂O and less than 20 cmH₂O. Turn CPAP regulator fully anti-clockwise and check that CPAP pressure is now less than 1.0 cmH₂O.

Set PIP alarm fully clockwise to above 60 cmH₂O. Turn PIP regulator to its maximum clockwise position and the CPAP regulator fully ACW and with inspiration control set to 3.0 seconds, press manual breath push-button and ensure that the PIP pressure exceeds 60.0 cmH₂O.

With Air & O₂ input pressures at 4.0 bar, press manual push button and observe PIP pressure, then reduce Air & O₂ to 3.5 bar and ensure PIP pressure still remains at 60 cmH₂O \pm 2 cmH₂O.

Connect Oxygen analyser to fresh gas supply and verify that oxygen output is accurate to within 3% of setting in 10% steps.

12.6 Pneumatic Circuit Diagram

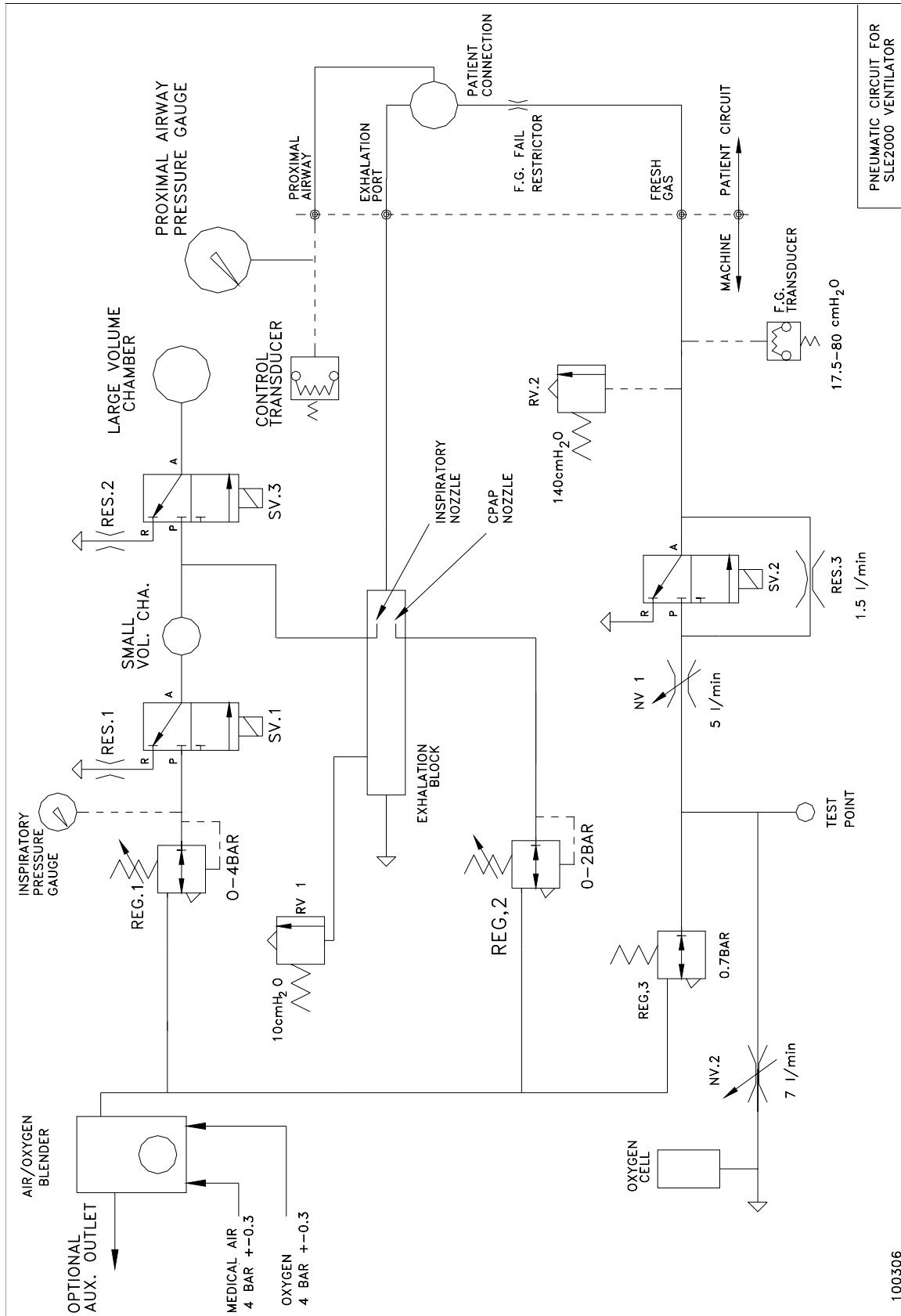

100306

12.7 Pneumatic Module Parts List

IT	DESCRIPTION	QTY	Part No.	IT	DESCRIPTION	QTY	Part No.
1	FIXING BLOCK (SMALL END)	1	T0237	32	SV2 BYPASS BLOCK	1	T0478
2	FIXING BLOCK (CROSS)	1	T0235	33	SOLENOID VALVE WITH BASE	3	N2195/NF15
3	SIDE COVER (FIXED)	1	T0198	34	SPACER	10	T0243
4	MAIN CHASSIS	1	T1009	35	GROMMET 4 X 6.3 X 1.6(16G)	7	M0402
5	BLENDER	1	N2185	36	RELIEF VALVE COVER	1	T0240
6	4 BAR REGULATOR - RELIEVING	1	N2181	37	ANALYZER BLOCK	1	T0228
7	PRESSURE GAUGE	1	N2183	38	ANALYZER BASE	1	T0226
8	2 BAR REGULATOR - RELIEVING	1	N2182	39	REGULATOR BRACKET	1	T0223
9	HUMIDIFIER CONNECTION	1	T0220	40	CAPTIVE NUT	2	T0224
10	PATIENT CONNECTION	1	T0219	41	RELIEF VALVE BLOCK	1	T0241
11	M6 FULL NUT-STAINLESS STEEL	2		42	2.0 PSI RELIEF VALVE	1	N2194
12	EXHAUST BLOCK ASSEMBLY	1	N2190	43	USE SCREWLOCK	AR	
13	FIXING BLOCK (END)	4	T0236	44	ANALYZER CONNECTOR	1	T0230
14	LATCH MOUNTING	1	T0250	45	O RING BS 011 EPDM	1	N2213
15	LATCH	1	T0252	46	OXYGEN CELL ASSEMBLY	1	N2191
16	30 LONG PIN FROM SET	1	T0251	47	O RING BS 008 EPDM	1	N2212
17	SPRING	1	M0319	48	VENT SCREW	1	T0229
18	O RING BS 017 SILICONE	1	N2211	49	BLENDER CONNECTOR	1	T0231
19	ALIGNMENT PIN	2	T0334	50	O RING BS 905 EPDM	1	N2178
20	ORIFICE BLOCK	1	T0238	51	SOLENOID SUPPORT	1	T1007
21	DOUBLE TEE	1	T0218	52	PARTITION	1	T0201
22	CONNECTOR CROSS	2	T0217	53	DOME PLUG	1	M0673/01
23	SEALING CAP	1	T0216	54	TOOL CLIP	2	N2377
24	F/G DUMP MANIFOLD	1	T0214	55	VOLUME CHAMBER	1	T0249
25	CLAMP BLOCK	2	T0233	56	HOUR METER+PLUG+HARNESS	1	W0287/01
26	O RING BS 010 EPDM	2	N2079	57	FASTENER DETAILS Sht 2 of drg	1	101011
27	BLENDER BRACKET	1	T0232	58	PIPING INFORMATION Sht 3 of drg	1	101004
28	2 BAR REGULATOR, NON-RELIEVING	1	N2180	59	VIB. ISOLATION GROMMET	3	M0402
29	RESTRICTOR SCREW	2	T0215	60	SOLENOID BRACKET (LARGE)	1	T1005
30	M3 FULL NUT - STAINLESS STEEL	2		61	SOLENOID BRACKET (SMALL)	1	T1006
31	ANALYZER BRACKET	1	T0981	62	SOLENOID LABEL	1	T1012

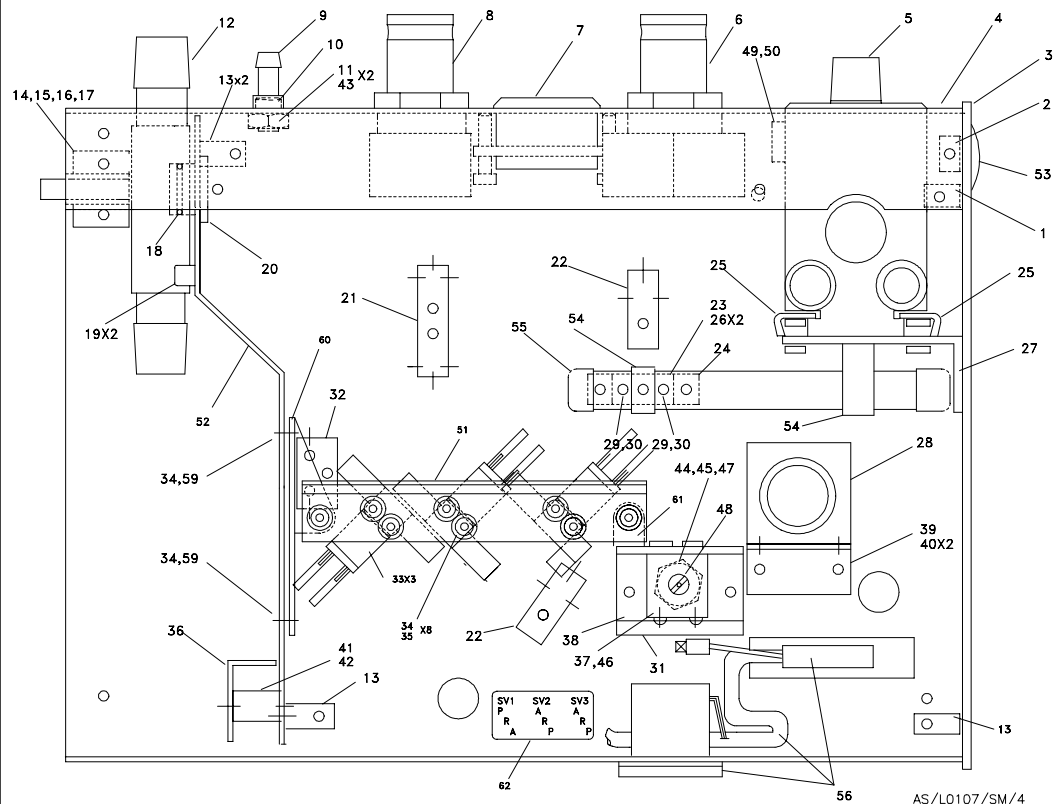

ITEM	DESCRIPTION	QTY	Part No.	ITEM	DESCRIPTION	QTY	Part No.
1	5/3 1/8 MALE STUD ELBOW	4	N2360	14	COUPLING	2	N2362/01
2	5/3 M5 SINGLE BANJO BODY	6	N2364	15	RESTRICTOR	2	N2370/01
3	M5 SINGLE BANJO BOLT (SHORT)	6	N2365	16	M5 FULL NUT ST.ST.	1	
*4	M5 ALUMINIUM WASHER	51	N2371/01	17	1/8 X 1/8 FEMALE ELBOW	1	N2366
5	M5 X 4.5 I.D. MALE HOSE ADAPTOR	14	N2369	18	1/8 X 1/8 MALE NIPPLE - TAPER	1	N2367
6	5/3 M5 MALE STUD CONNECTOR	21	N2362	19	PU 5/3 TUBING 3.4M	1	N2372
7	5/3 1/8 MALE STUD CONN.(TAPER)	3	N2361	20	PU 6/4 TUBING 0.4m	1	N2373
8	M5 BLANKING PLUG	1	N2370	21	TYGON 1/4X1/8 TUBING S50HL CLASSY1 2.0m	1	N2030
9	1/8 BSP X 1/8 ID TYGON ADAPTOR	1	N2381/01	22	"Y" CONNECTOR	1	N2339
10	PTFE THREAD TAPE	AR		23	DEFLECTOR	1	T0481
11				24	1/8 X 1/8 FEMALE SOCKET	1	N2368
12	6/4 M5 MALE STUD CONNECTOR	2	N2363	25	PLUG FOR REGULATORS	3	N2180/01
13	WASHER	2	T0280/01				

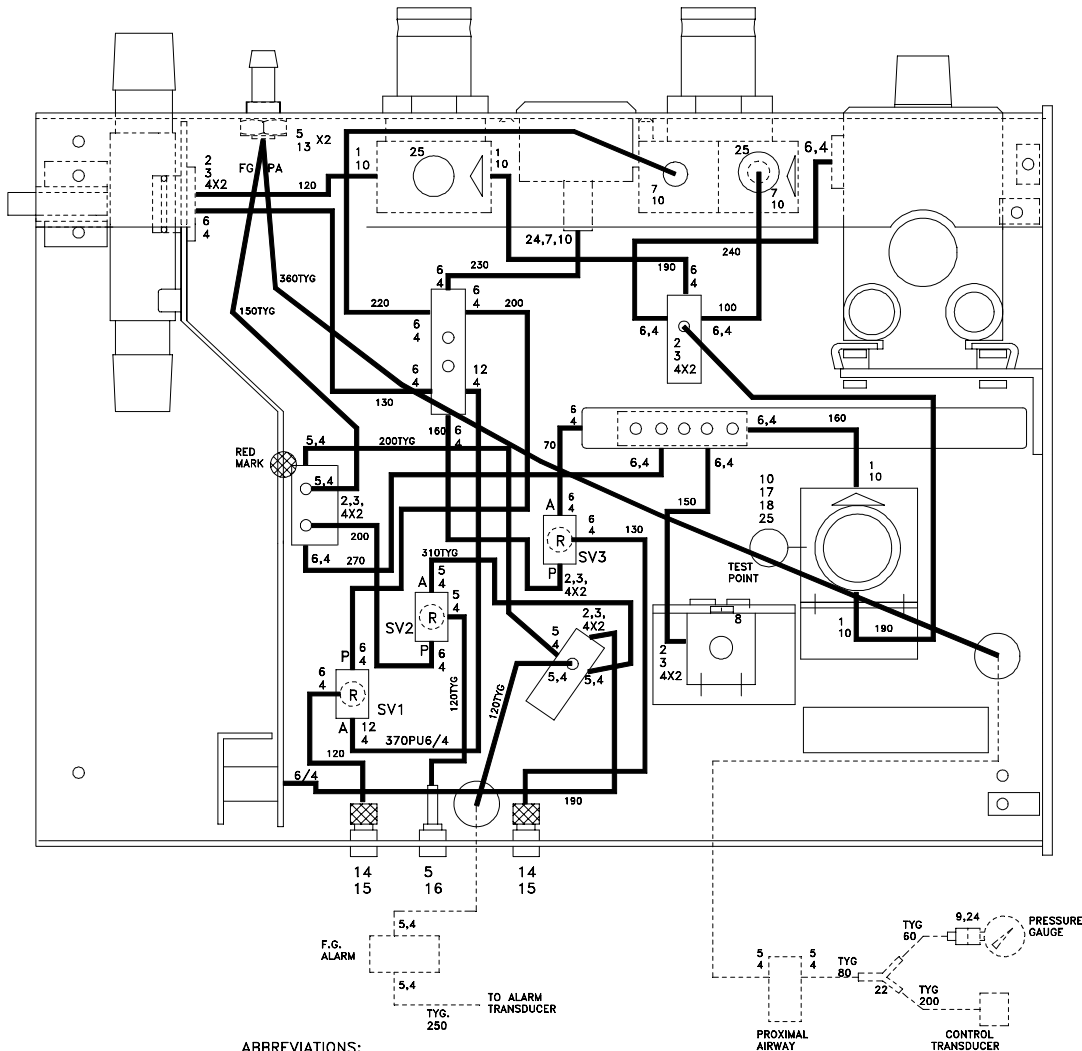

ABBREVIATIONS:
 PU6/4 = 6 DIA OD X 4 DIA ID POLYURETHANE TUBING
 TYG. = 1/4 OD X 1/8 ID TYGON
 ALL OTHER TUBING IS PU5/3

AS/L0107/SM/5

12.8 SLE 2000 Pneumatic Troubleshooting Chart

Sympton	Possible Cause	Remedy
Blender:		
Audible Alarm when Air & O ₂ supplies are connected	<ol style="list-style-type: none"> 1. Air/O₂ differential pressure exceeds 30PSI 2. Jammed Alarm 	<p>Ensure Air/O₂ differential pressure is less than 20PSI</p> <p>Disconnected Air & O₂ supplies and reconnect. If fault persists, reject blender.</p>
% O ₂ error exceeds $\pm 3\%$	<ol style="list-style-type: none"> 1. Digital FIO₂ reading requires adjustment. 	<p>Check % O₂ with suitable calibration reference. Adjust digital readout as appropriate. If fault persists, reject blender.</p>
Block/Leak Alarm:		
Leak alarm when patient circuit is connected.	<ol style="list-style-type: none"> 1. No Air/O₂ supply. 2. Excessive PIP. 3. Leak in patient circuit. 4. Fault is fresh gas supply. 	<p>Connect supply gas as appropriate.</p> <p>Adjust PIP alarm threshold or PIP regulator and press reset.</p> <p>Check humidifier for leaks. Check restrictor is in correct position.</p> <p>With reset button held in, occlude fresh gas port. If BLOCK alarm does not replace LEAK alarm, contact qualified Service Engineer.</p>
Block alarm	<ol style="list-style-type: none"> 1. Blockage in fresh gas supply. 	<p>Replace patient circuit.</p>
Low Peak Inspiration Pressure	<ol style="list-style-type: none"> 1. Low Air/O₂ supply pressures. 	<p>Ensure Air/O₂ supply = 4 Bar.</p>



	<p>2. PIP alarm threshold too low.</p> <p>3. Fault in patient circuit.</p> <p>4. Exhalation block not properly located.</p> <p>5. Blocked Inspiratory nozzle.</p> <p>6. Faulty PIP regulator</p>	<p>Adjust PIP alarm threshold.</p> <p>Replace patient circuit.</p> <p>Relocate exhalation block.</p> <p>Refer to qualified Service Engineer</p> <p>Refer to qualified Service Engineer</p>
CPAP	Desired CPAP pressure cannot be achieved.	As for PIP (see above).
Excessive residual PEEP	Faulty Patient circuit.	Replace patient circuit



**Technical
Specification**



13. Technical Specification

13.1 Conventional Ventilation

Modes:	CPAP,CMV,PTV,SIMV
BPM Ranges:	1-125 or 126 - 250 breaths per minute (1BPM STEPS) selected via rear security key switch
Inspiratory Time:	0.1-3.0 or 0.01-0.3 seconds
I:E Range :	9.9:1 - 1:9.9 calculated from BPM and INSP. TIME settings.
CPAP Pressure:	0 cmH2O to 15 cmH2O minimum.
Inspiratory Pressure:	0 cmH2O to 60 cmH2O switched fast or slow rise waveforms.

13.2 Displays

Proximal Airway Pressure Gauge	Gauge range -6 to +60 cmH ₂ O
Seven segment LED's:	showing BPM, INSP. TIME, I:E RATIO, FIO ₂ and PRESSURE (max., mean or min.).
Indicator LEDs:	POWER: green LED indicates power on. SYSTEM FAIL: Indicates main processor system fail. TRIGGER BACK-UP: Indicates a machine delivered breath if patient fails to trigger ventilator during back-up time window. MAX., MEAN, MIN.: indicates which value is being displayed on the 7 segment pressure display. MUTE: Indicates that the mute function is active.
Alarm LED's	LOW CPAP : warning of the pressure dropping below the LOW CPAP alarm limit CYCLE FAIL: warning that no breath has been detected. Ventilator breath is below alarm threshold. HIGH: warning of the PIP alarm limit being exceeded BLOCK: warning of a block in the fresh gas supply limb of patient circuit. LEAK : warning of a leak in the fresh gas supply limb of the patient circuit.

Driving Pressure Gauge:
(Scaled for resultant inspiratory pressures above **PEEP**)

Gauge range :0-60 cmH₂O plus PEEP level

13.3 Controls

Ventilation mode switch: OFF, ALARM TEST/CPAP, CMV, PTV, SIMV

BPM Control (ten turn): either 1-125BPM or 126-250BPM

INSP. TIME Control (ten turn): either 0.10-3.00 seconds (min exp time: 0.25 seconds) or 0.01-0.3 seconds (min exp time: 0.12)

Pressure Display Switch: MAX., MEAN, MIN.

Pressure Wave Switch: Slow or Fast rise

Manual Breath Pushbutton

Alarm Mute and Reset Pushbuttons: Mute active for 60 seconds (approx.)

Trigger Sensitivity Control: Range: 2ml/0.5 sec max. To 10ml/0.5sec min. Using SLE N2188 patient circuit.

Pressure alarm setting controls: LOW CPAP: -5 to 15cmH₂O
PIP :10 to 60 cmH₂O

Pressure controls: INSPIRATORY
CPAP/PEEP

Air/Oxygen Blender Control 21-100% ± 3%

13.4 Alarms

Audible only:

Loss of mains supply: Battery powered alarm
Loss of Air or O₂ supply: Blender alarm.

Audible and Visual:

HIGH CIRCUIT PRESSURE
CYCLE FAIL
LOW CIRCUIT PRESSURE
FRESH GAS BLOCK
FRESH GAS LEAK or TOTAL GAS SUPPLY FAIL
SYSTEM FAIL: FAIL.



13.5 Power , Dimensions etc.

Voltage :	100-120V/ 50-60 Hz 220-250V/ 50-60 Hz
Power :	120 VA
Fuses :	220-250V~50-60 Hz : Fuse T 1.0A 100-120V~50-60 Hz : Fuse T 2.0A
Air and O ₂ :	4 bar
Operating Environment:	Temp: 10-40°C Humidity: 0-90% (non condensing)
Size, Ventilator only :	37 cms W x 31 cms H x 32 cms D
Height on pole:	137 cms
Weight Ventilator Only:	10 Kgs
Complies with:	CE DECLARATION OF CONFORMITY IEC 601-1 and 601-2-12 1988 BS 5724 Part 1 and section 2.12.1990 EMC Medical device 601-1-2
Patient Circuit Required:	Model : N2188 Single use. or variant Model : N2200 Re-usable. or variant
Transport and storage conditions	Temperature -20 to 50°C for not longer than 2.5 months Humidity 15 to 90% (non condensing) for not longer than 2.5 months Atmospheric pressure 500 to 1060hPa for not longer than 2.5 months
Protection	Class 1 Type B Protection against electric Shock
Mode of operation	Continuous



Circuit Details

14. Electronic Circuit Details

14.1 Display Board A0700/01

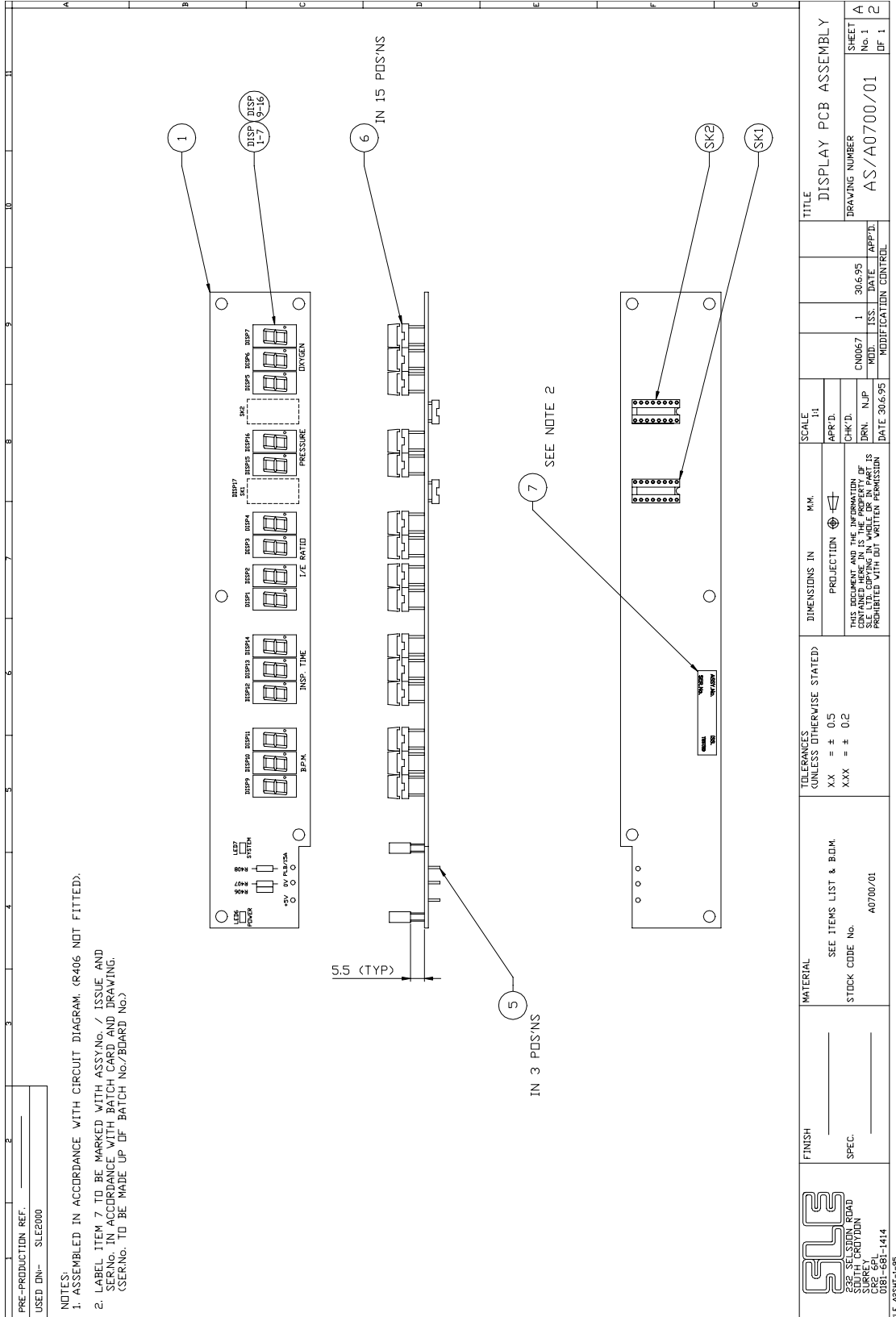

PRE-PRODUCTION REF. _____
 USED ON- SLE2000

- NOTES:
1. ASSEMBLED IN ACCORDANCE WITH CIRCUIT DIAGRAM. (R406 NOT FITTED).
 2. LABEL ITEM 7 TO BE MARKED WITH ASSY. NO. / ISSUE AND SERING. IN ACCORDANCE WITH BATCH CARD AND DRAWING. (SERING. TO BE MADE UP OF BATCH NO./BOARD NO.)

FINISH	MATERIAL	SEE ITEMS LIST & B.O.M.	TOLERANCES UNLESS OTHERWISE STATED: XX = ± 0.5 XXX = ± 0.2	DIMENSIONS IN MM. PROJECTION	SCALE 1:1	TITLE	
						DISPLAY PCB ASSEMBLY	DRAWING NUMBER AS/A0700/01
SPEC.	STOCK CODE No. A0700/01					CHK'D. CND067	ISS. DATE 30.6.95
						DRN. NUP	APPT. DATE
						MODIFICATION CONTROL	
							SHEET No. 1 OF 2
							OF 1

14.1.1 Display Board Circuit Diagram A0700/01

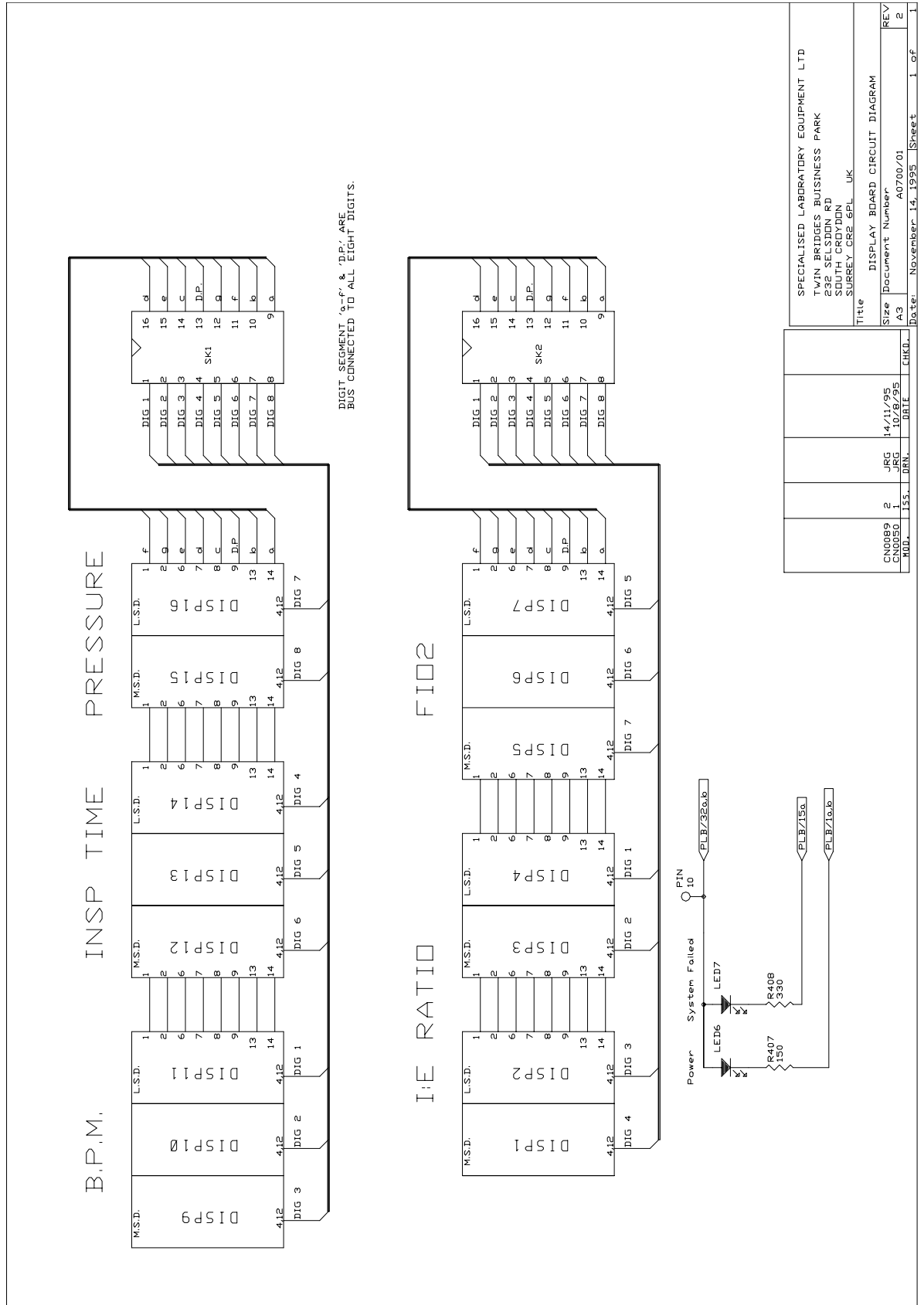

SPECIALISED LABORATORY EQUIPMENT LTD TWIN BRIDGES BUSINESS PARK 232 SELSDON RD SOUTH CROYDON SURREY CR2 6PL UK	
Title	DISPLAY BOARD CIRCUIT DIAGRAM
Size	Document Number
REV	A3 A0700/01
2	
NO0089 2	JRG 14/11/95
CN0050 1	JRG 10/8/95
RD.	155. DRN.
	CHKD.
	DATE
	1 of 1
	Date: November 14, 1995
	Sheet



PARTS LIST

Finished Item Stock Number **A0700/01**
Finished Item Description Display PCB Assembly
Drawing Number AS/A0700/01 Issue 2

Part Number	Component Description	Qty Used	Component Reference(s)
J0700	Display Board blank	1	ITEM 1 (PCB)
D0308	LED Green Rectangular LGB480EH	1	LED 6
D0546	LED Red Rectangular LSB480EH	1	LED 7
D0590	Display 7 Segment MAN4640A	15	DISP 1-7, DISP 9-16.
M0307	Terminal Pin(Pcb single sided)	3	ITEM 5
R0424	330R Resistor 1% 0.25W SMA0207	1	R408
R0416	150R Resistor 1% 0.25W SMA0207	1	R407
S0212	IC Socket 16 way DIL	2	SK1 & SK2
S0445	Socket 14 way DIL	15	ITEM 6
M0718	Label, PCB Identification	1	ITEM 7

14.2 LED Board A0701/01

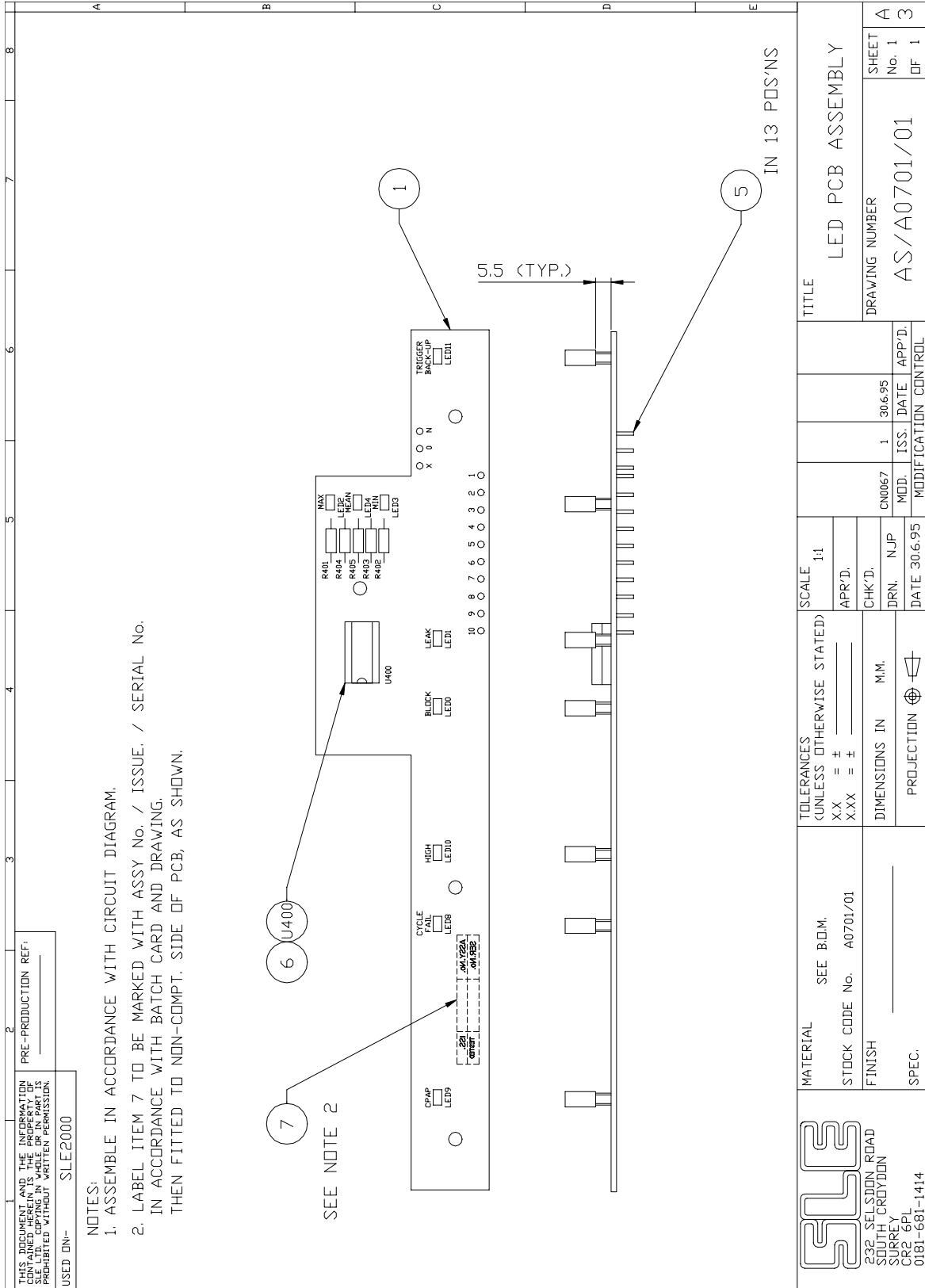

THIS DOCUMENT AND THE INFORMATION CONTAINED HEREIN ARE THE PROPERTY OF SLE LTD. COPYING IN WHOLE OR IN PART IS PROHIBITED WITHOUT WRITTEN PERMISSION.

USED ON:- SLE2000

NOTES:

- ASSEMBLE IN ACCORDANCE WITH CIRCUIT DIAGRAM.
- LABEL ITEM 7 TO BE MARKED WITH ASSY No. / ISSUE. / SERIAL No. IN ACCORDANCE WITH BATCH CARD AND DRAWING. THEN FITTED TO NON-COMPT. SIDE OF PCB, AS SHOWN.

14.2.1 LED Circuit Board Diagram CD/A0701/01

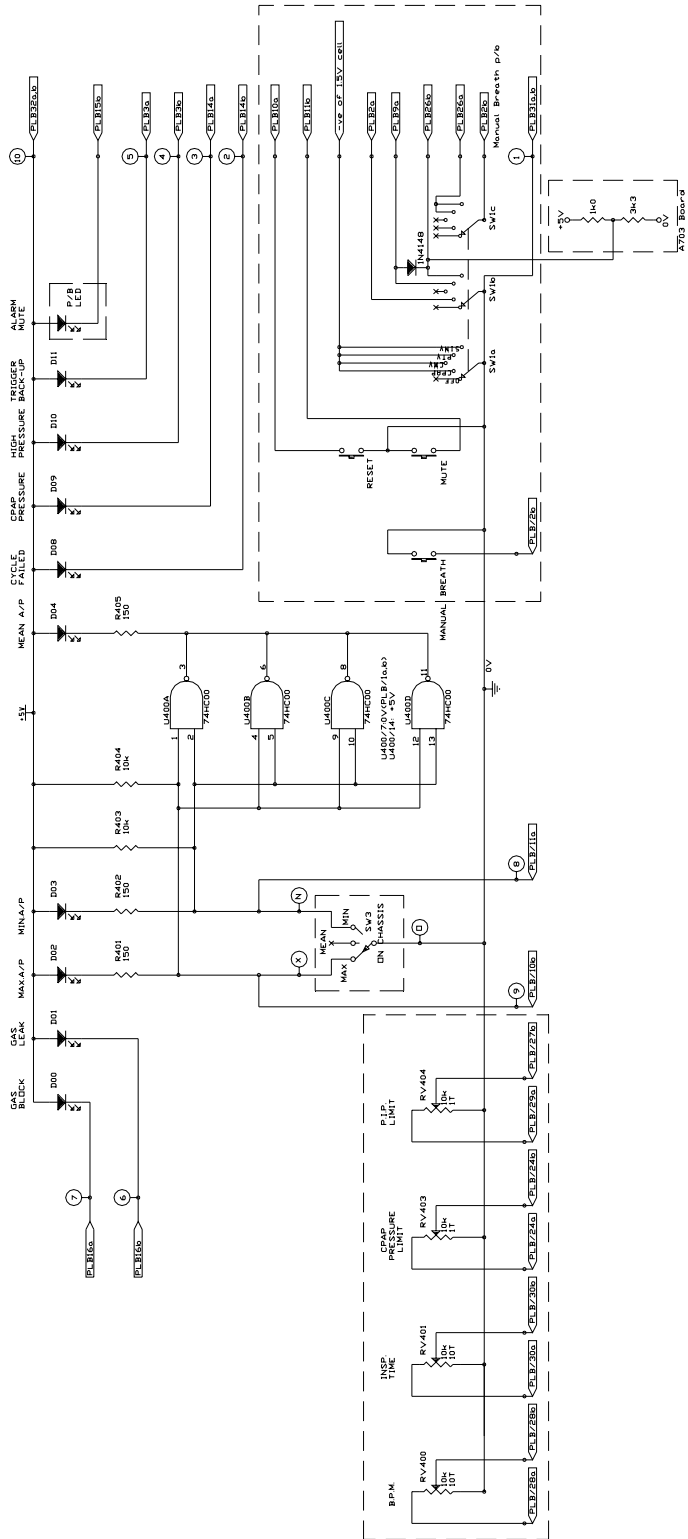

NOTES
 1. Dashed lines indicate components mounted on front panel or elsewhere if otherwise stated

SLE Limited Business Park 232 Seaborn Road South Croaydon, Surrey	
Title LED BOARD CIRCUIT DIAGRAM	
Size A4	Document Number CD/A0701/01
Scale 1:1	Date November 17, 1995
Sheet 1 of 1	REV 2

PARTS LIST

Finished Item Stock Number A0701/01
Finished Item Description LED PCB Assembly
Drawing Number AS/A0701/01 Issue 1

Part Number	Component Description	Qty Used	Component Reference(s)
J0701	LED pcb blank	1	ITEM 1 (PCB)
D0308	LED Green Rectangular LGB480EH	3	LED2,3,4
D0508	74HC00	1	U400
D0546	LED Red Rectangular LSB480EH	6	LED 0,1,8,9,10,11
M0307	Terminal Pin(Pcb single sided)	13	ITEM 5
R0463	10K Resistor 1% 0.25W SMA0207	2	R403,404
R0416	150R Resistor 1% 0.25W SMA0207	3	R401, 402, 405
S0242	IC Socket 14 way DIL	1	ITEM 6 (U400)
M0718	Label, PCB Identification	1	ITEM 7



CPU Board AS/A0702/01

AS/A0702/01 Issue 4: Standard board (See board drawing AS/A0702/01 issue 4 on page 69 and circuit diagram CD/A0702/01 issue 2 on page 70).

Stabilization of leak alarm trigger threshold

AS/A0702/01 Issue 5: Addition of capacitor C0481 to stabilize leak alarm trigger threshold (See board drawing AS/A0702/01 issue 5 on page 76 and circuit diagram CD/A0702/01 issue 6 on page 77).

Also see service information "SI 000201 Leak Alarm Trigger Threshold." on page 118.

Alarm sounder failing to operate in fresh gas blocked alarm conditions

AS/A0702/01 Issue 5: No change. Reference of modification see Detail A on page 82.

CD/A0702/01 Issue 7: Modification of circuit diagram to show track cut between C500 to U500 pin 7, Connection of link between C500 and U500 pin 8 and connection of a 68M resistor across pin 5 and 7.

(See board drawing AS/A0702/01 issue 5 on page 81 and circuit diagram CD/A0702/01 issue 6 on page 83).



14.3.1 Ventilator CPU Board CD/A0702/01 Issue 2 Sheet 1 of 3

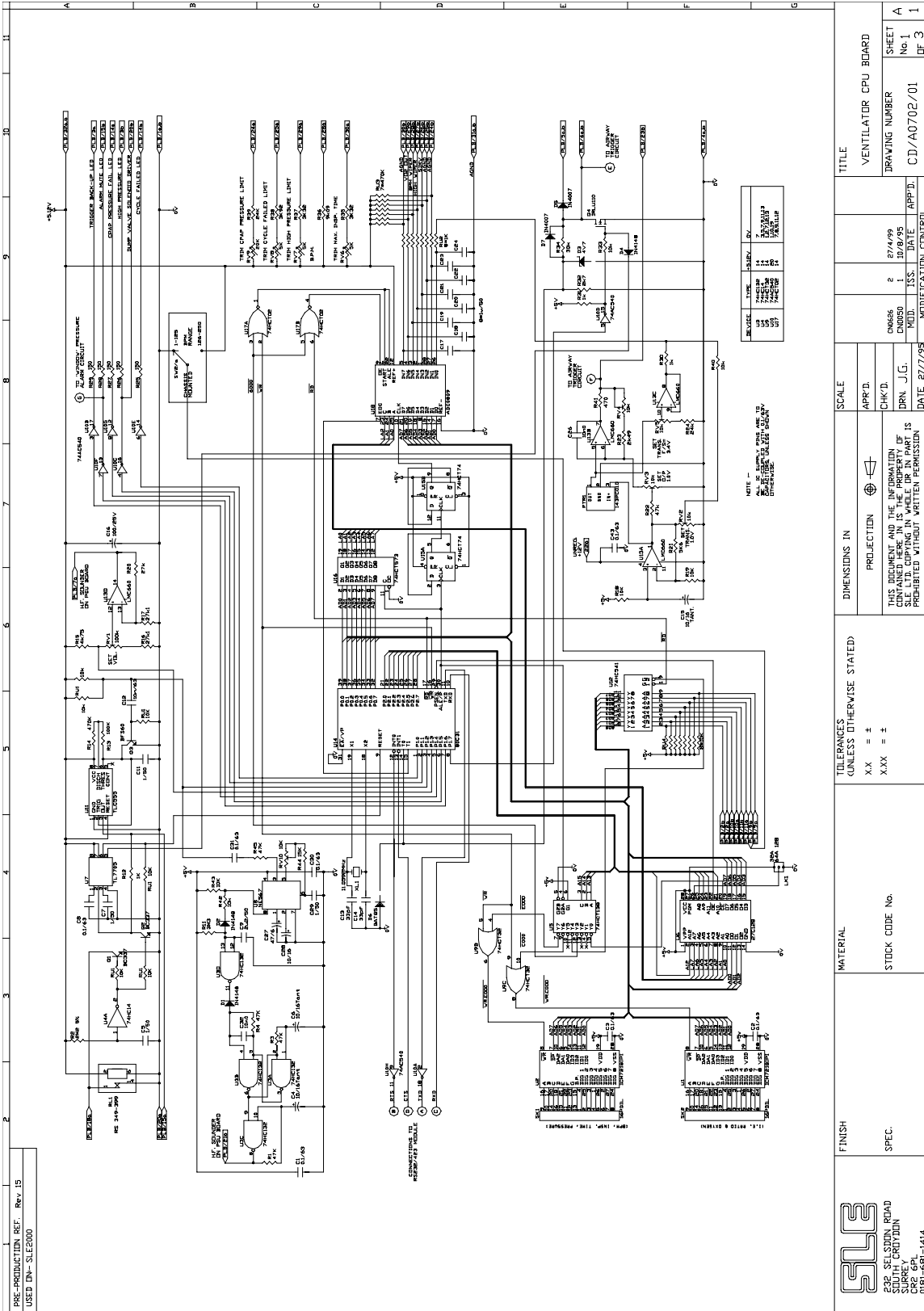

A3 version on page 101 of circuit diagram appendix.



14.3.3 Window Pressure Alarm A0702/01 Sheet 3 of 3

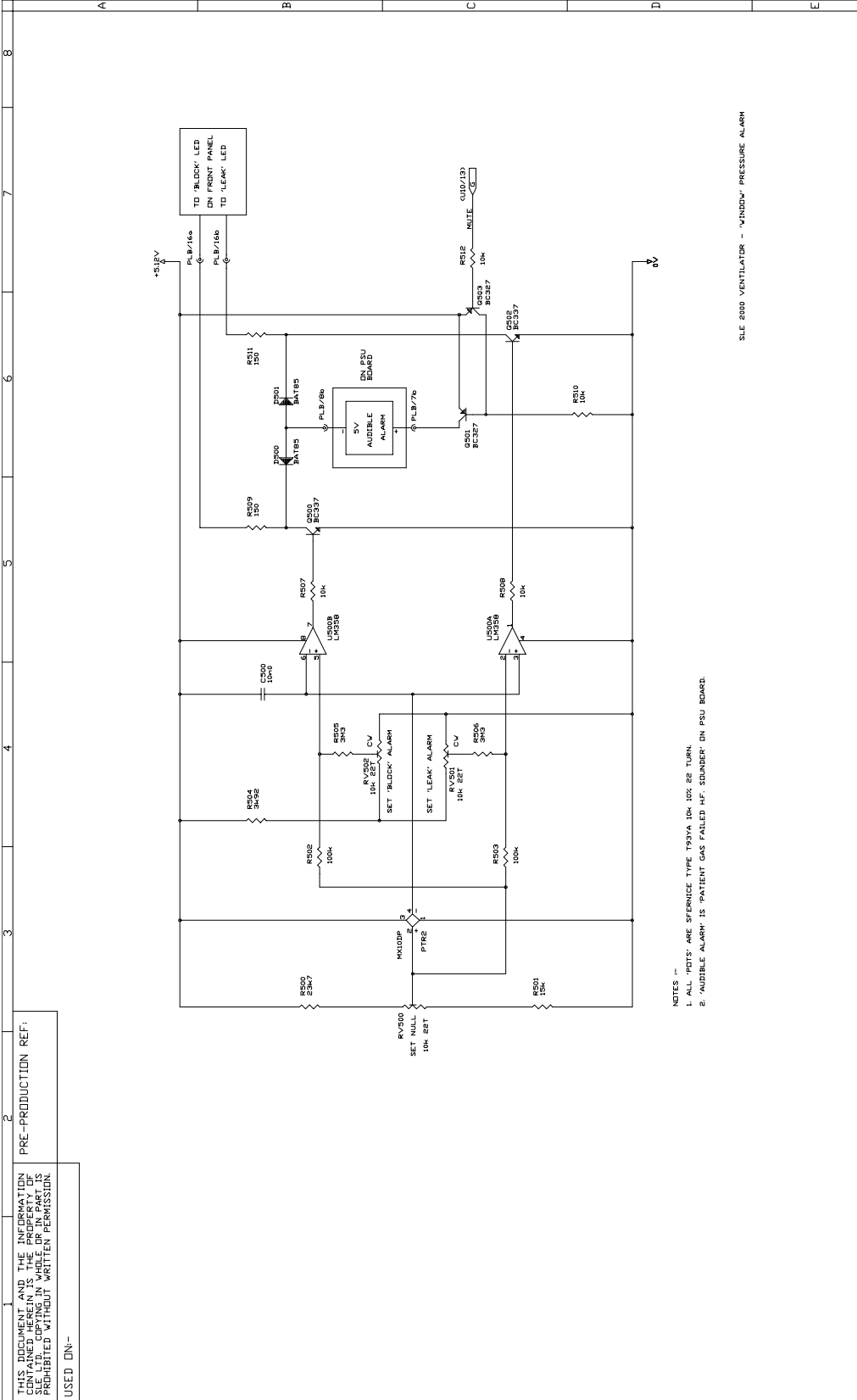

SLE 2000 VENTILATOR - 'WINDOW' PRESSURE ALARM

NOTES :-
 1. ALL 'POTS' ARE SPERFACE TYPE T93YA 10K 10% 25 TURN.
 2. 'AUDIBLE ALARM' IS 'PATENT GAS FAILED M.F. SOUNDER' ON PSU BOARD.

THIS DOCUMENT AND THE INFORMATION CONTAINED HEREIN IS THE PROPERTY OF SLE. UNAUTHORIZED COPYING OR REPRODUCTION IS STRICTLY PROHIBITED WITHOUT WRITTEN PERMISSION.
 USED ON:-

PRE-PRODUCTION REF:	
MATERIAL	TOLERANCES (UNLESS OTHERWISE STATED) X.X = ± X.XX = ±
STOCK CODE No.	APR'D.
FINISH	CHK'D.
SPEC.	DRN. J.G
	DATE 27/7/95
	PROJECTION
	MOD. ISS. DATE APP'D.
	CM0050 1 10/8/95
	MODIFICATION CONTROL

SLE 232 SELSDON ROAD SOUTH CROYDON SURREY CR2 6PL 0181-681-1414	TITLE		SHEET No. 3 OF 3
	A0702 WINDOW PRESSURE ALARM		
	DRAWING NUMBER		A
	A0702/01		3

66-1-10REV 75

PARTS LIST

Finished Item Stock Number A0702/01
 Finished Item Description Ventilator CPU PCB Assembly
 Drawing Number AS/A0702/01 Issue 4

Part Number	Component Description	Qty Used	Component Reference(s)
J0702	Ventilator CPU pcb blank	1.00 Each	ITEM 1 (PCB Rev D)
Check pressure transducer type (ITEM PTR2) and read note for component pre-fix.			
C0256	47uF Capacitor 16V 10-20% Tan.	1.00 Each	C27
C0260	10nF Capacitor 63V 20% MXS2	4.00 Each	C12,C26,C32 & C500
C0434	10u Capacitor 35V 20% 5mm Lead	4.00 Each	C4,C6,C15 & C28
C0439	100u Capacitor 25V 20% Elect.	1.00 Each	C16
C0441	470uF Capacitor 25V 20%	1.00 Each	C203
C0450	0.1uF Capacitor 63V 10% MKS2	18.00 Each	C1-3,8,30,31,C33-43 & C204
C0459	2.2uF Capacitor 50V 10%	3.00 Each	C9,C201 & & C202
C0461	33pF Capacitor 100V 10% Ceram.	2.00 Each	C13 & & C14
C0462	1uF Capacitor 50/63V 10% MKS2	14.00 Each	C5,7,11,C17-24,C29,C200 & C205
D0284	BZX79C4V7 (was BZY88C 4v7)	1.00 Each	D3
D0288	LM358N	1.00 Each	U500=Pt No.D0586 when pre-fix is not 'S' for PTR2
D0298	ICM7218DIJ1 28 Pin Harris	2 00 Each	U1 & U2
D0305	ADC0809CCN NSC	1.00 Each	U18
D0320	74HC132N	1.00 Each	U3
D0336	BC337	4.00 Each	Q1,Q2,Q500 & Q502
D0402	IN4007 Plastic Diode	2.00 Each	D5 & D7 (CN0626)
D0406	1N4148	4.00 Each	D1,D2,D4 & & D201
D0407	BAT85	4.00 Each	D6.D202.D500.D501
D0513	74HC14	1.00 Each	U4
D0525	4066 Quad Bilateral Switch	1.00 Each	U201
D0566	TL7705ACP	1.00 Each	U7
D0569	BAT81	1.00 Each	D200
D0570	Crystal 11.0592 MHz	1.00 Each	XL1
D0571	74HCT138N	1.00 Each	U5
D0572	74HCT32N	1.00 Each	U9
D0573	74HCT74N	1.00 Each	U15
D0574	74HCT573N	1.00 Each	U16
D0575	74HCT02N	1.00 Each	U17
D0576/01	27C128-20/P	1.00 Each	U6
D0577	LM567CN	1.00 Each	U8
D0578	74AC540	1.00 Each	U10



Part Number	Component Description	Qty Used	Component Reference(s)
D0579	74HC541	1.00 Each	U12
D0580	TLCSSSCP	1.00 Each	U11
D0581	LMC660AIN	2.00 Each	U13 & & U202
D0582	80C31P (Phillips)	1.00 Each	U14
D0584	CD40106BE	1.00 Each	U200
D0585	BC327	2.00 Each	Q501 & Q503
D0636	IRLU110 power MOSFET,TO-251	1.00 Each	Q4
D0638	ZTX450	1.00 Each	Q3
M0626	Jumper Link	1.00 Each	ITEM 5
M0660	Pad Adhesive double sided	1.00 Each	ITEM 15
M0692	Transistor Pad T05	1.00 Each	
M0718	Label, PCB Identification	1.00 Each	ITEM 17
N2113	Pressure Transducer 142SCOID	1.00 Each	PTR1
N2176	Sensor SXOIDN (Sensym only)	1.00 Each	PTR2
If N2176 is not Pre-Fixed with M on component then R501 becomes 33K(PT No.R0473) & U500 becomes LM358(PT No.D0288)			
00227	Relay W172DIP-5 5V DC	1.00 Each	RL1
P0230	DIN41612 64 Way 90 deg Plug	1.00 Each	PLB
P0464	12way P.C.B Header Straight	0.25 Each	LKI (3 PIN SECTION)
R0224	30K Resistor 0.25W 18	0 00 Each	replaced by R0549 CN626
R0226	110K Resistor 1% 0.25W	1.00 Each	R208
R0349	24K Resistor 0.25W 1%	2.00 Each	R24 & & R39
R0350	1K x 8 Resistor Network	1.00 Each	RU2
R0351	10K x 8 Resistor Network	1.00 Each	RU1
R0416	150R Resistor 1% 0.25W SMA0207	7.00 Each	R25-R29,R509 & R511
R0428	470R Resistor 1% 0.25W	1.00 Each	R41
R0436	1.0K Resistor 1% 0.25W SMA0207	6.00 Each	R12,R30,R31,R205-R207
R0445	2K49 Resistor 1% 0.25W SMA0207	1.00 Each	R23
R0446	2.7K Resistor 1% 0.25W	0.00 Each	replaced by R0461CN0626
R0449	3.32K Resistor 1% 0.25W SMA	2.00 Each	R35 & & R37
R0451	3.92K Resistor 1% 0.25W SMA020	2.00 Each	R38 & & R504
R0454	4.75K Resistor 1% 0.25W	1.00 Each	R15
R0456	5.6K Resistor 1% 0.25W SMA0207	1.00 Each	R21
R0461	8.2K Resistor 1% 0.25W	1.00 Each	R32
R0462	9.09K Resistor 1% 0.25W SMA020	1.00 Each	R36
R0463	10K Resistor 1% 0.25W SMA0207	10.00 Each	R18,19,33,40,42,43,507,508,510 & R512
R0467	15K Resistor 1% 0.25W SMA0207	1.00 Each	R44
R0469	22.1K Resistor 1% 0.25W SMA020	1.00 Each	R204
R0470	23.7K Resistor 1% 0.25W	1.00 Each	R500

Part Number	Component Description	Qty Used	Component Reference(s)
R0471	27K Resistor 1k 0.25W SMA0207	3.00 Each	R16,R17 & R20
R0473	33K Resistor 1% 0.25W	1.00 Each	R501=Pt No.R0467when pre-fix is not 'S' for PTR2
R0479	47K Resistor 1% 0.25W SMA0207	5.00 Each	R1,R3,R4,R22 & R45
R0486	100K Resistor 1% 0.25W SMA0207	7.00 Each	R13,R201,202,209 ,210,502,R503
R0496	470K Resistor 1% 0.25W SMA0207	1.00 Each	R14
R0499	750K Resistor 1% 0.25W	1.00 Each	R203
R0501	1.0M Resistor 1% 0.25W SMA0207	2.00 Each	R211 & R212
R0504	2.2M Resistor 16 0.25W	1.00 Each	R2
R0506	3.3M Resistor 1% 0.25W SMA0207	3.00 Each	R11,R505 & R506
R0549	91K Resistor 1% 0.25w	1.00 Each	R34
R0555	470K x 8 Resistor Network	1.00 Each	RU3
R0556	10K x 8 Resistor Network	1.00 Each	RU4
R0571	10k Resistor 1% 0.125W M/Film	2.00 Each	R213 & R214
S0209	IC Socket 28 way DIL	4.00 Each	ITEM 12
S0212	IC Socket 16 way DIL	5.00 Each	ITEM 10 (U5,RU1,2,SKI & SK2)
S0227	IC Socket 40 way DIL	1.00 Each	ITEM 13
S0237	IC Socket 20 way DIL	3.00 Each	ITEM 11
S0241	IC Socket 8 way DIL	4.00 Each	ITEM 8 (U7,8,11& U500)
S0242	IC Socket 14 way DIL	9.00 Each	ITEM 9
T0205	Alarm Transducer Bracket	1.00 Each	ITEM 3
V0404	5.0K Trimmer,cermet,top adjust	3.00 Each	RV6-RV8
V0405	10K Trimmer, cermet, top adj	5.00 Each	RV2-RV5 & RV10
V0406	20K Trimmer cermet,top adjust	2.00 Each	RV9,RV202
V0408	100K Trimmer, cermet, top adj	1.00 Each	RV1
V0410	500K Trimmer	1.00 Each	RV200
V0414	10K Trimmer, cermet, top adj	3.00 Each	RV500-RV502
H3116	M3 x 16 Pan Hd Pozi s.st	2.00 Each	ITEM 22
H3108	M3 x 8 Pan Hd Pozi s.st	2.00 Each	ITEM 21
H3225	M3 x 25 Csk Hd Pozi s.st	2.00 Each	ITEM 23
H2312	M2.5 x 12 Pan Hd Pozi s.st	2.00 Each	ITEM 20
H3091	M3 Nut Full s.st	6.00 Each	ITEM 26
H2591	M2.5 Nut Full s.st	2.00 Each	ITEM 25
H2595	M2.5 Plain Nylon Washer	2.00 Each	ITEM 32
H3094	M3 S/Proof Washer s.st DIN6798	6.00 Each	ITEM 28
H3095	M3 Plain Washer Nylon	6.00 Each	ITEM 30
H3093	M3 Plain Washer B . st	2.00 Each	ITEM 29

14.4.1 Ventilator CPU Board CD/A0702/01 Issue 6

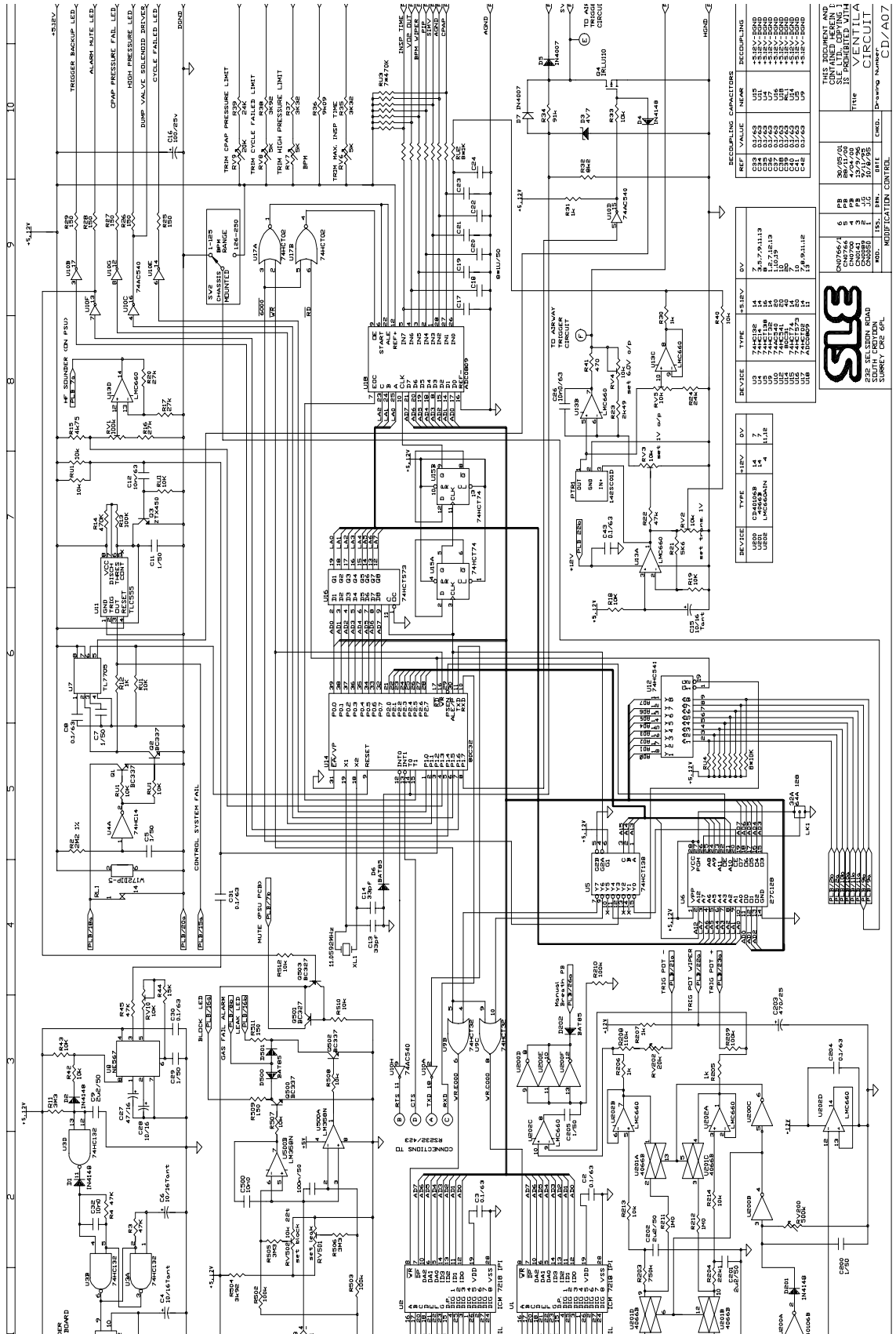

A3 version on page 103 of circuit diagram appendix.



PARTS LIST

Finished Item Stock Number A0702/01
 Finished Item Description Ventilator CPU PCB Assembly
 Drawing Number AS/A0702/01 Issue 5

Part Number	Component Description	Qty Used	Component Reference(s)
J0702	Ventilator CPU pcb blank	1.00 Each	ITEM 1 (PCB Rev D)
Check pressure transducer type (ITEM PTR2) and read note for component pre-fix.			
C0256	47uF Capacitor 16V 10-20% Tan.	1.00 Each	C27
C0260	10nF Capacitor 63V 20% MXS2	4.00 Each	C12,C26,C32 & C500
C0434	10u Capacitor 35V 20% 5mm Lead	4.00 Each	C4,C6,C15 & C28
C0439	100u Capacitor 25V 20% Elect.	1.00 Each	C16
C0441	470uF Capacitor 25V 20%	1.00 Each	C203
C0450	0.1uF Capacitor 63V 10% MKS2	18.00 Each	C1-3,8,30,31,C33-43 & C204
C0459	2.2uF Capacitor 50V 10%	3.00 Each	C9,C201 & & C202
C0461	33pF Capacitor 100V 10% Ceram.	2.00 Each	C13 & & C14
C0462	1uF Capacitor 50/63V 10% MKS2	14.00 Each	C5,7,11,C17-24,C29,C200 & C205
C0481	100nf Capacitor 50v	1.00 Each	C2
D0284	BZX79C4V7 (was BZY88C 4v7)	1.00 Each	D3
D0288	LM358N	1.00 Each	U500=Pt No.D0586 when pre-fix is not 'S' for PTR2
D0298	ICM7218DIJ1 28 Pin Harris	2 00 Each	U1 & U2
D0305	ADC0809CCN NSC	1.00 Each	U18
D0320	74HC132N	1.00 Each	U3
D0336	BC337	4.00 Each	Q1,Q2,Q500 & Q502
D0402	IN4007 Plastic Diode	2.00 Each	D5 & D7 (CN0626)
D0406	1N4148	4.00 Each	D1,D2,D4 & & D201
D0407	BAT85	4.00 Each	D6.D202.D500.D501
D0513	74HC14	1.00 Each	U4
D0525	4066 Quad Bilateral Switch	1.00 Each	U201
D0566	TL7705ACP	1.00 Each	U7
D0569	BAT81	1.00 Each	D200
D0570	Crystal 11.0592 MHz	1.00 Each	XL1
D0571	74HCT138N	1.00 Each	U5
D0572	74HCT32N	1.00 Each	U9
D0573	74HCT74N	1.00 Each	U15
D0574	74HCT573N	1.00 Each	U16
D0575	74HCT02N	1.00 Each	U17
D0576/01	27C128-20/P	1.00 Each	U6
D0577	LM567CN	1.00 Each	U8

Part Number	Component Description	Qty Used	Component Reference(s)
D0578	74AC540	1.00 Each	U10
D0579	74HC541	1.00 Each	U12
D0580	TLCSSSCP	1.00 Each	U11
D0581	LMC660AIN	2.00 Each	U13 & & U202
D0584	CD40106BE	1.00 Each	U200
D0585	BC327	2.00 Each	Q501 & Q503
D0636	IRLU110 power MOSFET,TO-251	1.00 Each	Q4
D0638	ZTX450	1.00 Each	Q3
D0644/01	P80C32EBPN 8-bit CMOS CPU	1.00 Each	U14
M0626	Jumper Link	1.00 Each	ITEM 5
M0660	Pad Adhesive double sided	1.00 Each	ITEM 15
M0692	Transistor Pad T05	1.00 Each	
M0718	Label, PCB Identification	1.00 Each	ITEM 17
N2113	Pressure Transducer 142SCOID	1.00 Each	PTR1
N2176	Sensor SXOIDN (Sensym only)	1.00 Each	PTR2
If N2176 is not Pre-Fixed with M on component then R501 becomes 33K(PT No.R0473) & U500 becomes LM358(PT No.D0288)			
00227	Relay W172DIP-5 5V DC	1.00 Each	RL1
P0230	DIN41612 64 Way 90 deg Plug	1.00 Each	PLB
P0464	12way P.C.B Header Straight	0.25 Each	LKI (3 PIN SECTION)
R0224	30K Resistor 0.25W 18	0 00 Each	replaced by R0549 CN0626
R0226	110K Resistor 1% 0.25W	1.00 Each	R208
R0349	24K Resistor 0.25W 1%	2.00 Each	R24 & & R39
R0350	1K x 8 Resistor Network	1.00 Each	RU2
R0351	10K x 8 Resistor Network	1.00 Each	RU1
R0416	150R Resistor 1% 0.25W SMA0207	7.00 Each	R25-R29,R509 & R511
R0428	470R Resistor 1% 0.25W	1.00 Each	R41
R0436	1.0K Resistor 1% 0.25W SMA0207	6.00 Each	R12,R30,R31,R205-R207
R0445	2K49 Resistor 1% 0.25W SMA0207	1.00 Each	R23
R0446	2.7K Resistor 1% 0.25W	0.00 Each	replaced by R0461CN0626
R0449	3.32K Resistor 1% 0.25W SMA	2.00 Each	R35 & & R37
R0451	3.92K Resistor 1% 0.25W SMA020	2.00 Each	R38 & & R504
R0454	4.75K Resistor 1% 0.25W	1.00 Each	R15
R0456	5.6K Resistor 1% 0.25W SMA0207	1.00 Each	R21
R0461	8.2K Resistor 1% 0.25W	1.00 Each	R32
R0462	9.09K Resistor 1% 0.25W SMA020	1.00 Each	R36
R0463	10K Resistor 1% 0.25W SMA0207	10.00 Each	R18,19,33,40,42,43,507,50 8,510 & R512
R0467	15K Resistor 1% 0.25W SMA0207	1.00 Each	R44



Part Number	Component Description	Qty Used	Component Reference(s)
R0469	22.1K Resistor 1% 0.25W SMA020	1.00 Each	R204
R0470	23.7K Resistor 1% 0.25W	1.00 Each	R500
R0471	27K Resistor 1k 0.25W SMA0207	3.00 Each	R16,R17 & R20
R0473	33K Resistor 1% 0.25W	1.00 Each	R501=Pt No.R0467when pre-fix is not 'S' for PTR2
R0479	47K Resistor 1% 0.25W SMA0207	5.00 Each	R1,R3,R4,R22 & R45
R0486	100K Resistor 1% 0.25W SMA0207	7.00 Each	R13,R201,202,209 ,210,502,R503
R0496	470K Resistor 1% 0.25W SMA0207	1.00 Each	R14
R0499	750K Resistor 1% 0.25W	1.00 Each	R203
R0501	1.0M Resistor 1% 0.25W SMA0207	2.00 Each	R211 & R212
R0504	2.2M Resistor 16 0.25W	1.00 Each	R2
R0506	3.3M Resistor 1% 0.25W SMA0207	3.00 Each	R11,R505 & R506
R0549	91K Resistor 1% 0.25w	1.00 Each	R34
R0555	470K x 8 Resistor Network	1.00 Each	RU3
R0556	10K x 8 Resistor Network	1.00 Each	RU4
R0571	10k Resistor 1% 0.125W M/Film	2.00 Each	R213 & R214
S0209	IC Socket 28 way DIL	4.00 Each	ITEM 12
S0212	IC Socket 16 way DIL	5.00 Each	ITEM 10 (U5,RU1,2 ,SKI & SK2)
S0227	IC Socket 40 way DIL	1.00 Each	ITEM 13
S0237	IC Socket 20 way DIL	3.00 Each	ITEM 11
S0241	IC Socket 8 way DIL	4.00 Each	ITEM 8 (U7,8,11&U500)
S0242	IC Socket 14 way DIL	9.00 Each	ITEM 9
T0205	Alarm Transducer Bracket	1.00 Each	ITEM 3
V0404	5.0K Trimmer,cermet,top adjust	3.00 Each	RV6-RV8
V0405	10K Trimmer, cermet, top adj	5.00 Each	RV2-RV5 & RV10
V0406	20K Trimmer cermet,top adjust	2.00 Each	RV9,RV202
V0408	100K Trimmer, cermet, top adj	1.00 Each	RV1
V0410	500K Trimmer	1.00 Each	RV200
V0414	10K Trimmer, cermet, top adj	3.00 Each	RV500-RV502
H3116	M3 x 16 Pan Hd Pozi s.st	2.00 Each	ITEM 22
H3108	M3 x 8 Pan Hd Pozi s.st	2.00 Each	ITEM 21
H3225	M3 x 25 Csk Hd Pozi s.st	2.00 Each	ITEM 23
H2312	M2.5 x 12 Pan Hd Pozi s.st	2.00 Each	ITEM 20
H3091	M3 Nut Full s.st	6.00 Each	ITEM 26
H2591	M2.5 Nut Full s.st	2.00 Each	ITEM 25
H2595	M2.5 Plain Nylon Washer	2.00 Each	ITEM 32
H3094	M3 S/Proof Washer s.st DIN6798	6.00 Each	ITEM 28
H3095	M3 Plain Washer Nylon	6.00 Each	ITEM 30
H3093	M3 Plain Washer B . st	2.00 Each	ITEM 29

14.5 Ventilator CPU Board AS/A0702/01 Issue 5

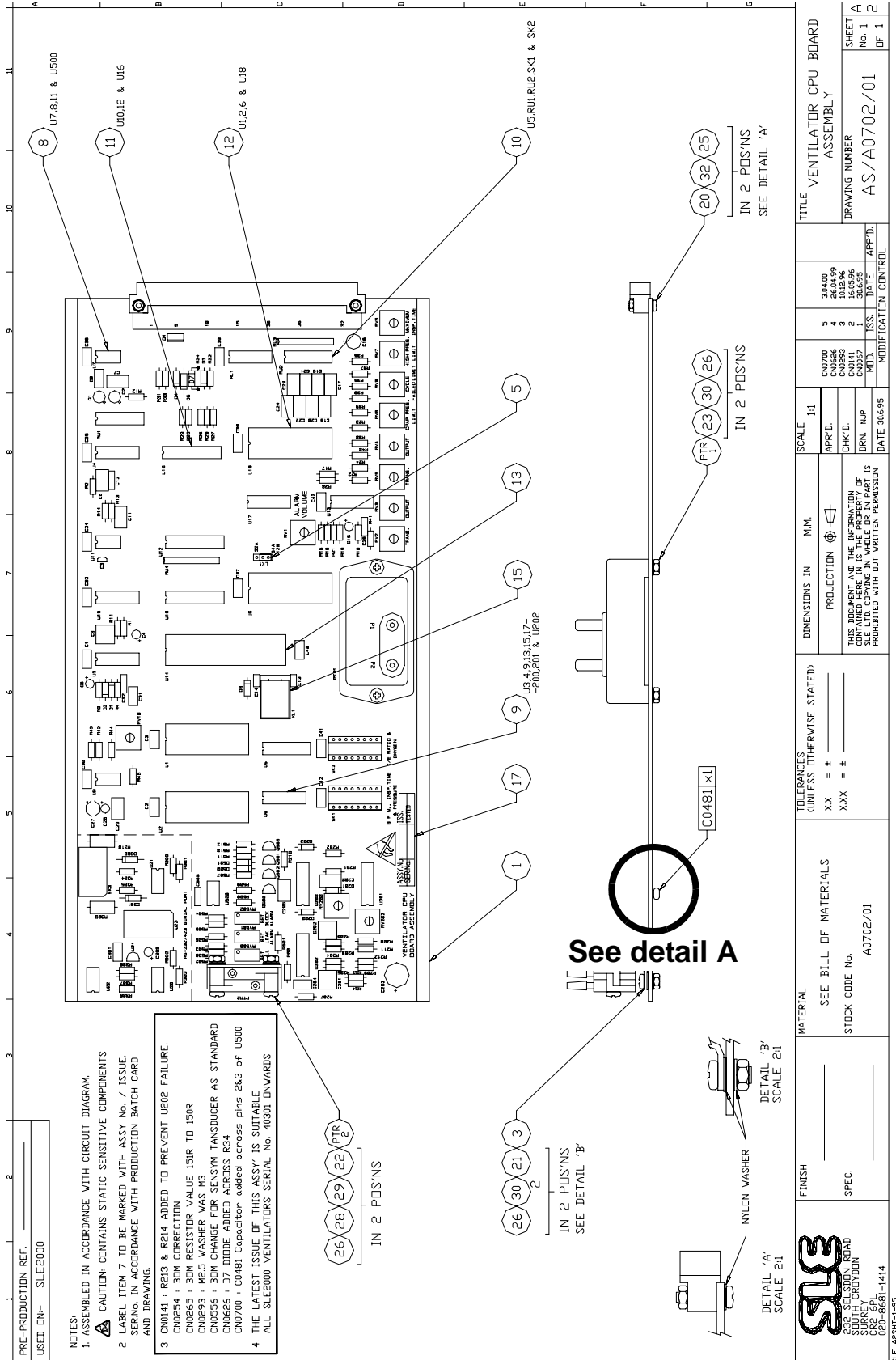

PRE-PRODUCTION REF. _____
USED DW- SLE2000

NOTES:
 1. ASSEMBLED IN ACCORDANCE WITH CIRCUIT DIAGRAM.
 2. CAUTION: CONTAINS STATIC SENSITIVE COMPONENTS
 3. LABEL ITEM 7 TO BE MARKED WITH ASSY No. / ISSUE, SERING. IN ACCORDANCE WITH PRODUCTION BATCH CARD AND DRAWING.
 4. CN0141 : R213 & R214 ADDED TO PREVENT U202 FAILURE.
 CN0254 : BOM CORRECTION
 CN0265 : BOM RESISTOR VALUE 151R TO 150R
 CN0293 : R2.5 WASHER WAS M3
 CN0556 : BOM CHANGE FOR SENSYM TRANSDUCER AS STANDARD
 CN0626 : B7 DIODE ADDED ACROSS R34
 CN0700 : C0481 Capacitor added across pins 2&3 of U500
 5. THE LATEST ISSUE OF THIS ASSY IS SUITABLE
 ALL SLE2000 VENTILATORS SERIAL No. 40301 ONWARDS

TITLE: VENTILATOR CPU BOARD ASSEMBLY
 DRAWING NUMBER: AS/A0702/01
 SHEET No. 1 OF 2

ISS. NO.	DATE	APP'D.	MODIFICATION CONTROL
1	26.04.99		
2	10.16.96		
3	30.05.95		
4			
5			

SCALE: 1:1
 DIMENSIONS IN M.M.
 PROJECTION: 1st Angle
 THIS DRAWING AND THE INFORMATION CONTAINED HEREIN IS THE PROPERTY OF SLE LTD. COPYING IN WHOLE OR IN PART IS PROHIBITED WITHOUT WRITTEN PERMISSION.

TOLERANCES (UNLESS OTHERWISE STATED):
 XX = ±
 XXX = ±

MATERIAL: SEE BILL OF MATERIALS
 STOCK CODE No. A0702/01

FINISH: _____
 SPEC: _____

SLE
 232 SELSIDA ROAD
 SOUTH CROYDON
 CR2 6PL
 020-6681-1414
 SLE A8971-1-95

14.5.1 Ventilator CPU Board (Detail A)

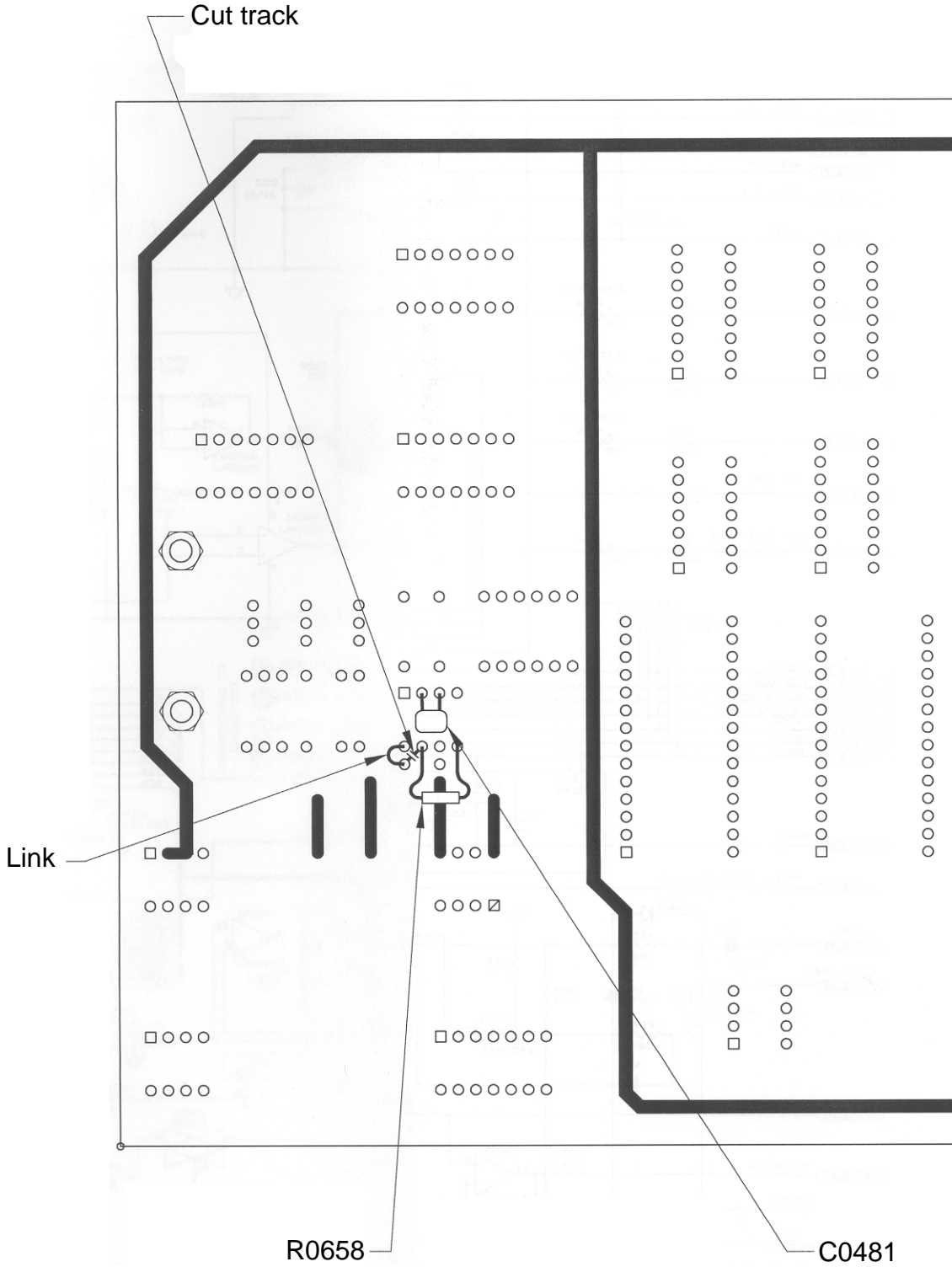

14.5.2 Ventilator CPU Board CD/A0702/01 Issue 7

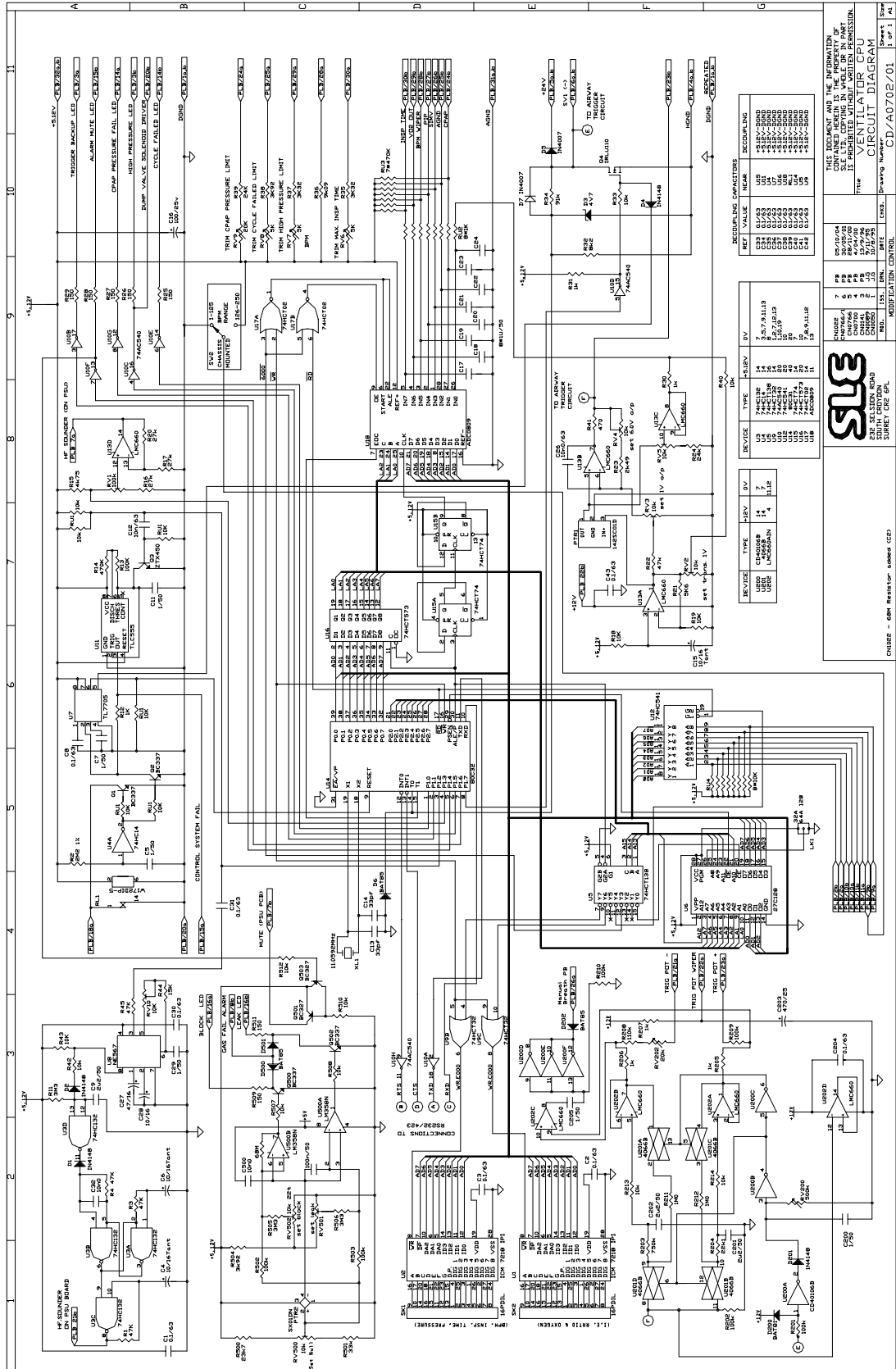

A3 version on page 105 of circuit diagram appendix.



PARTS LIST

Finished Item Stock Number A0702/01
 Finished Item Description Ventilator CPU PCB Assembly
 Drawing Number AS/A0702/01 Issue 5 but for CD/A0702/01 issue 7

Part Number	Component Description	Qty Used	Component Reference(s)
J0702	Ventilator CPU pcb blank	1.00 Each	ITEM 1 (PCB Rev D)
Check pressure transducer type (ITEM PTR2) and read note for component pre-fix.			
C0256	47uF Capacitor 16V 10-20% Tan.	1.00 Each	C27
C0260	10nF Capacitor 63V 20% MXS2	4.00 Each	C12,C26,C32 & C500
C0434	10u Capacitor 35V 20% 5mm Lead	4.00 Each	C4,C6,C15 & C28
C0439	100u Capacitor 25V 20% Elect.	1.00 Each	C16
C0441	470uF Capacitor 25V 20%	1.00 Each	C203
C0450	0.1uF Capacitor 63V 10% MKS2	18.00 Each	C1-3,8,30,31,C33-43 & C204
C0459	2.2uF Capacitor 50V 10%	3.00 Each	C9,C201 & & C202
C0461	33pF Capacitor 100V 10% Ceram.	2.00 Each	C13 & & C14
C0462	1uF Capacitor 50/63V 10% MKS2	14.00 Each	C5,7,11,C17-24,C29,C200 & C205
C0481	100nf Capacitor 50v	1.00 Each	C2
D0284	BZX79C4V7 (was BZY88C 4v7)	1.00 Each	D3
D0288	LM358N	1.00 Each	U500=Pt No.D0586 when pre-fix is not 'S' for PTR2
D0298	ICM7218DIJ1 28 Pin Harris	2.00 Each	U1 & U2
D0305	ADC0809CCN NSC	1.00 Each	U18
D0320	74HC132N	1.00 Each	U3
D0336	BC337	4.00 Each	Q1,Q2,Q500 & Q502
D0402	IN4007 Plastic Diode	2.00 Each	D5 & D7 (CN0626)
D0406	1N4148	4.00 Each	D1,D2,D4 & & D201
D0407	BAT85	4.00 Each	D6.D202.D500.D501
D0513	74HC14	1.00 Each	U4
D0525	4066 Quad Bilateral Switch	1.00 Each	U201
D0566	TL7705ACP	1.00 Each	U7
D0569	BAT81	1.00 Each	D200
D0570	Crystal 11.0592 MHz	1.00 Each	XL1
D0571	74HCT138N	1.00 Each	U5
D0572	74HCT32N	1.00 Each	U9
D0573	74HCT74N	1.00 Each	U15
D0574	74HCT573N	1.00 Each	U16
D0575	74HCT02N	1.00 Each	U17
D0576/01	27C128-20/P	1.00 Each	U6
D0577	LM567CN	1.00 Each	U8

Part Number	Component Description	Qty Used	Component Reference(s)
D0578	74AC540	1.00 Each	U10
D0579	74HC541	1.00 Each	U12
D0580	TLCSSSCP	1.00 Each	U11
D0581	LMC660AIN	2.00 Each	U13 & & U202
D0584	CD40106BE	1.00 Each	U200
D0585	BC327	2.00 Each	Q501 & Q503
D0636	IRLU110 power MOSFET,TO-251	1.00 Each	Q4
D0638	ZTX450	1.00 Each	Q3
D0644/01	P80C32EBPN 8-bit CMOS CPU	1.00 Each	U14
M0626	Jumper Link	1.00 Each	ITEM 5
M0660	Pad Adhesive double sided	1.00 Each	ITEM 15
M0692	Transistor Pad T05	1.00 Each	
M0718	Label, PCB Identification	1.00 Each	ITEM 17
N2113	Pressure Transducer 142SCOID	1.00 Each	PTR1
N2176	Sensor SXOIDN (Sensym only)	1.00 Each	PTR2
If N2176 is not Pre-Fixed with M on component then R501 becomes 33K(PT No.R0473) & U500 becomes LM358(PT No.D0288)			
00227	Relay W172DIP-5 5V DC	1.00 Each	RL1
P0230	DIN41612 64 Way 90 deg Plug	1.00 Each	PLB
P0464	12way P.C.B Header Straight	0.25 Each	LKI (3 PIN SECTION)
R0224	30K Resistor 0.25W 18	0 00 Each	replaced by R0549 CN0626
R0226	110K Resistor 1% 0.25W	1.00 Each	R208
R0349	24K Resistor 0.25W 1%	2.00 Each	R24 & & R39
R0350	1K x 8 Resistor Network	1.00 Each	RU2
R0351	10K x 8 Resistor Network	1.00 Each	RU1
R0416	150R Resistor 1% 0.25W SMA0207	7.00 Each	R25-R29,R509 & R511
R0428	470R Resistor 1% 0.25W	1.00 Each	R41
R0436	1.0K Resistor 1% 0.25W SMA0207	6.00 Each	R12,R30,R31,R205-R207
R0445	2K49 Resistor 1% 0.25W SMA0207	1.00 Each	R23
R0446	2.7K Resistor 1% 0.25W	0.00 Each	replaced by R0461CN0626
R0449	3.32K Resistor 1% 0.25W SMA	2.00 Each	R35 & & R37
R0451	3.92K Resistor 1% 0.25W SMA020	2.00 Each	R38 & & R504
R0454	4.75K Resistor 1% 0.25W	1.00 Each	R15
R0456	5.6K Resistor 1% 0.25W SMA0207	1.00 Each	R21
R0461	8.2K Resistor 1% 0.25W	1.00 Each	R32
R0462	9.09K Resistor 1% 0.25W SMA020	1.00 Each	R36
R0463	10K Resistor 1% 0.25W SMA0207	10.00 Each	R18,19,33,40,42,43,507,50 8,510 & R512
R0467	15K Resistor 1% 0.25W SMA0207	1.00 Each	R44



Part Number	Component Description	Qty Used	Component Reference(s)
R0469	22.1K Resistor 1% 0.25W SMA020	1.00 Each	R204
R0470	23.7K Resistor 1% 0.25W	1.00 Each	R500
R0471	27K Resistor 1k 0.25W SMA0207	3.00 Each	R16,R17 & R20
R0473	33K Resistor 1% 0.25W	1.00 Each	R501=Pt No.R0467when pre-fix is not 'S' for PTR2
R0479	47K Resistor 1% 0.25W SMA0207	5.00 Each	R1,R3,R4,R22 & R45
R0486	100K Resistor 1% 0.25W SMA0207	7.00 Each	R13,R201,202,209 ,210,502,R503
R0496	470K Resistor 1% 0.25W SMA0207	1.00 Each	R14
R0499	750K Resistor 1% 0.25W	1.00 Each	R203
R0501	1.0M Resistor 1% 0.25W SMA0207	2.00 Each	R211 & R212
R0504	2.2M Resistor 16 0.25W	1.00 Each	R2
R0506	3.3M Resistor 1% 0.25W SMA0207	3.00 Each	R11,R505 & R506
R0549	91K Resistor 1% 0.25w	1.00 Each	R34
R0555	470K x 8 Resistor Network	1.00 Each	RU3
R0556	10K x 8 Resistor Network	1.00 Each	RU4
R0571	10k Resistor 1% 0.125W M/Film	2.00 Each	R213 & R214
R0658	68M Resistor 0.25W High Ohmic	1.00 Each	
S0209	IC Socket 28 way DIL	4.00 Each	ITEM 12
S0212	IC Socket 16 way DIL	5.00 Each	ITEM 10 (U5,RU1,2 ,SKI & SK2)
S0227	IC Socket 40 way DIL	1.00 Each	ITEM 13
S0237	IC Socket 20 way DIL	3.00 Each	ITEM 11
S0241	IC Socket 8 way DIL	4.00 Each	ITEM 8 (U7,8,11&U500)
S0242	IC Socket 14 way DIL	9.00 Each	ITEM 9
T0205	Alarm Transducer Bracket	1.00 Each	ITEM 3
V0404	5.0K Trimmer,cermet,top adjust	3.00 Each	RV6-RV8
V0405	10K Trimmer, cermet, top adj	5.00 Each	RV2-RV5 & RV10
V0406	20K Trimmer cermet,top adjust	2.00 Each	RV9,RV202
V0408	100K Trimmer, cermet, top adj	1.00 Each	RV1
V0410	500K Trimmer	1.00 Each	RV200
V0414	10K Trimmer, cermet, top adj	3.00 Each	RV500-RV502
H3116	M3 x 16 Pan Hd Pozi s.st	2.00 Each	ITEM 22
H3108	M3 x 8 Pan Hd Pozi s.st	2.00 Each	ITEM 21
H3225	M3 x 25 Csk Hd Pozi s.st	2.00 Each	ITEM 23
H2312	M2.5 x 12 Pan Hd Pozi s.st	2.00 Each	ITEM 20
H3091	M3 Nut Full s.st	6.00 Each	ITEM 26
H2591	M2.5 Nut Full s.st	2.00 Each	ITEM 25
H2595	M2.5 Plain Nylon Washer	2.00 Each	ITEM 32
H3094	M3 S/Proof Washer s.st DIN6798	6.00 Each	ITEM 28
H3095	M3 Plain Washer Nylon	6.00 Each	ITEM 30

Part Number	Component Description	Qty Used	Component Reference(s)
H3093	M3 Plain Washer B . st	2.00 Each	ITEM 29
W0112	Tinned copper wire 22swg	0.01 Metre	See detail A



14.6 RS232/423 Option

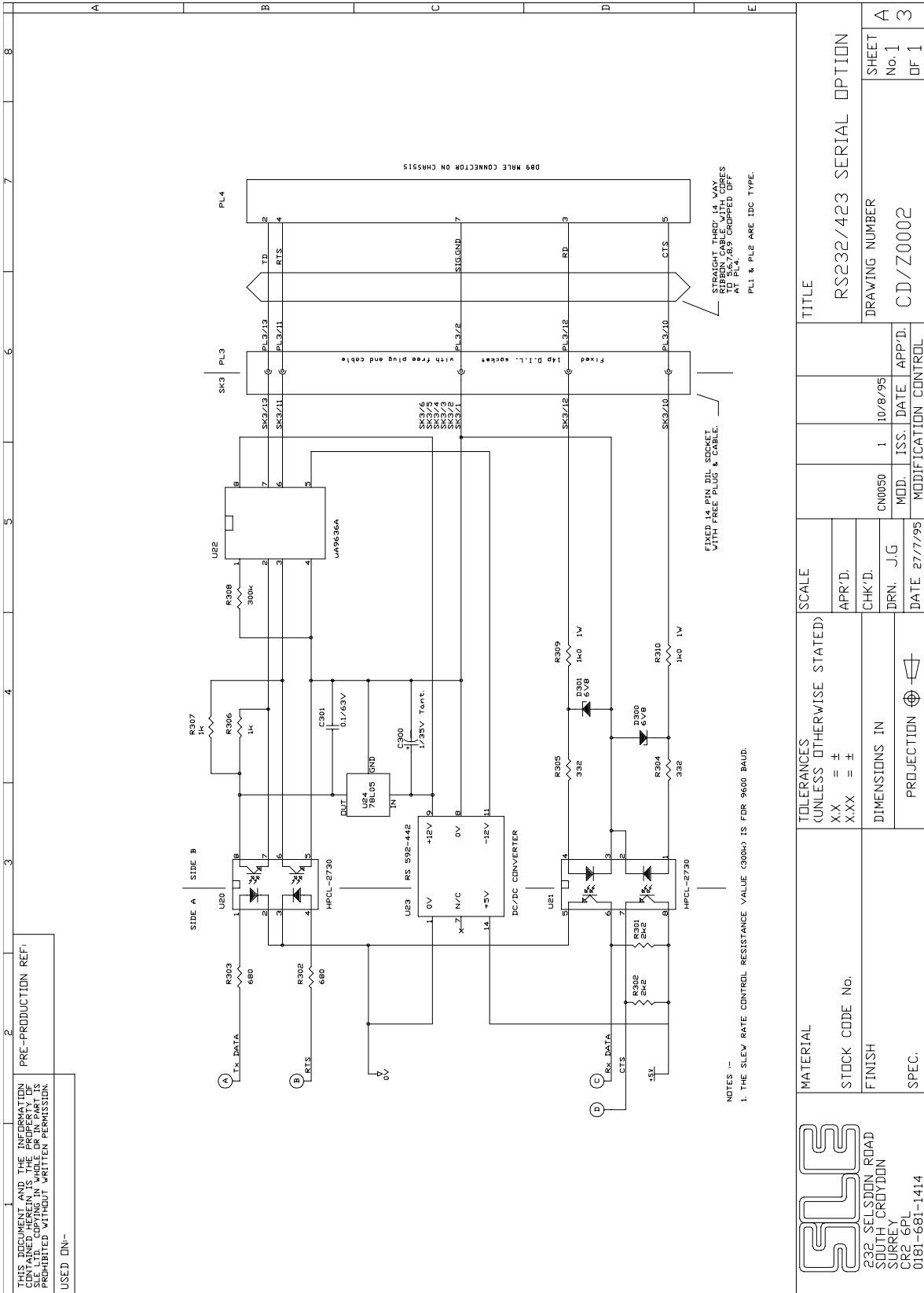

NOTES -
 1. THE SLEV RATE CONTROL RESISTANCE VALUE (300K) IS FOR 9600 BAUD.

THIS DOCUMENT AND THE INFORMATION CONTAINED HEREIN IS THE PROPERTY OF SLE. NO REPRODUCTION OR DISTRIBUTION OF THIS DOCUMENT OR THE INFORMATION CONTAINED HEREIN IS PERMITTED WITHOUT WRITTEN PERMISSION.
 USED ON:-

MATERIAL STOCK CODE No. FINISH 232 SELSDON ROAD SUDBURY CP2 6PL 0181-681-1414		TOLERANCES (UNLESS OTHERWISE STATED) XX = ± XXX = ±		SCALE APR'D. CHK'D. DRN. J.G DATE 27/7/95		TITLE RS232/423 SERIAL OPTION		SHEET No. 1 OF 3	
FINISH DIMENSIONS IN PROJECTION		MOD. CN0050 1 10/8/95 MOD. ISS. DATE APP'D. MODIFICATION CONTROL		DRAWING NUMBER CD/Z0002					

PARTS LIST

Finished Item Stock Number

A0702/03

Finished Item Description

RS232/423 option.(A0702 PCB)

Part Number	Component Description	Qty Used	Component Reference(s)
D0643	HPCL 2730	2	U20,21
D0640	UA9636ACP	1	U22
D0593	NMA0512D	1	U23
D0432	LM7805CT Regulator	1	U24
D0250	BZX79C6V8	2	D300,301
R0443	2.2K Resistor 1% 0.25W SMA0207	2	R300,301
R0432	680R Resistor 1% 0.25W	2	R302,303
R0425	332R Resistor 1% 0.25W SMA0207	2	R304,305
R0436	1.0K Resistor 1% 0.25W SMA0207	2	R306,307
R0343	300K 1% 50PPM 0.25W	1	R308
R0557	1K0 Resistor 5% 1W 250PPM PR01	2	R309,310
C0433	1uF Capacitor 35V 20% Tantalum	1	C300
C0450	0.1uF Capacitor 63V 10% MKS2	1	C301
S0241	IC Socket 8 way DIL	3	U20,21,22
S0242	IC Socket 14 way DIL	1	SK3



PARTS LIST

Finished Item Stock Number A0703/01
 Finish-d Item Description PSU Pcb Assembly
 Drawing Number AS/A0703/01 Issue 3

Part Number	Component Description	Qty Used	Component Reference(s)
J0703	PSU Pcb A0703 Rev.B.	1.00 Each	ITEM 1 (PCB)
C0214	330pf 100v Ceramic 10% PCM5	1.00 Each	C104
C0252	2200uF Capacitor 25V 20%	1.00 Each	C102 (fix to pcb using silicone rubber compound)
C0450	0.1uF Capacitor 63V 10% MKS2	1.00 Each	C103
C0462	1uF Capacitor 50/63V 10t MKS2	1.00 Each	C100
C0463	47uF Capacitor 100V 208	0.00 Each	replaced by C0517
C0517	220uF Capacitor 100 Volts 20%	1.00 Each	C101
D0402	IN4007 Plastic Diode	0.00 Each	replaced by D0711
D0711	Zener Diode IN5359B 24v 5w	1.00 Each	D102
D0411	KBPC104 Bridge Rectifier	2.00 Each	D100,D101
D0427	LM336Z5/0 Diode	1.00 Each	D103
D0537	LM317T	1.00 Each	U101
D0583	LT1006CN&	1.00 Each	U100
D0636	IRLU110 power MOSFET, TO-251	1.00 Each	Q100
M0228	Heat Sink TO-220	1.00 Each	ITEM 5
M0307	Terminal Pin(Pcb single sided)	33.00 Each	ITEM 7
M0309/01	H12 x 20mm Sleeve (1.2mm I/D)	2.00 Each	ITEM 9
M0458/01	Heatsink (Drilled)	2.00 Each	ITEM 6
M0463	T0220 Transistor Heatsink	1.00 Each	ITEM 2
M0626	Jumper Link	1.00 Each	ITEM 3 (LK2)
M0718	Label, PCB Identification	1.00 Each	ITEM 8
N2082	SMB-01 Audible Alarm	1.00 Each	BZ4
N2096	SMA-24L Audible Alarm 98dB	3.00 Each	BZ1-BZ3
P0464	12way P.C.B Header Straight	0.10 Each	LK2 (Cut into 2 Pin Section)
R0270	620R Resistor 1% 0.25W SMA0207	1.00 Each	R113
R0355	240R Resistor 1% 0.25W SMA0207	1.00 Each	R115
R0405	10R Resistor 1% 0.25W SMA0207	1.00 Each	R102
R0413	100R Resistor 1% 0.25W SMA0207	1.00 Each	R107
R0424	330R Resistor 1% 0.25W SMA0207	1.00 Each	R117
R0425	332R Resistor 1% 0.25W SMA0207	1.00 Each	R103
R0436	1.0K Resistor 1% 0.25W SMA0207	3.00 Each	R109,116,121
R0445	2K49 Resistor 1% 0.25W SMA0207	3.00 Each	R101,104,105
R0448	3K16 Resistor 1% 0.25W SMA0207	1.00 Each	R112
R0449	3.32K Resistor 1% 0.25W SMA	1.00 Each	R122

Part Number	Component Description	Qty Used	Component Reference(s)
R0457	6K8 Resistor 1% 0.25W SMA0207	1.00 Each	R111
R0463	10K Resistor 1% 0.25W SMA0207	1.00 Each	R114
R0469	22.1K Resistor 1% 0.25W SMA020	1.00 Each	R120
R0478	45K3 Resistor 1% 0.25W SMA0207	1.00 Each	R108
R0501	1.0M Resistor 1% 0.25W SMA0207	1.00 Each	R100
R0553	330R Resistor 5W HS10 (ARCOL)	2.00 Each	R106,110
R0650	56R Resistor 5% 6w W22 Series	1.00 Each	Fitted at LK1
S0241	IC Socket 8 way DIL	1.00 Each	ITEM 4 (U100)
V0401	200R Trimmer, cermet, top adj.	1.00 Each	RV102
V0426	5K Trimmer, cermet, top adjust	1.00 Each	RV101
H2108	M2 x 8 Pan Hd Pozi s.st	6.00 Each	ITEM 10 & 11
H3108	M3 x 8 Pan Hd Pozi s.st	1.00 Each	ITEM 12
H2091	M2 Nut Full s.st	6.00 Each	ITEM 20
H3091	M3 Nut Full s.st	1.00 Each	ITEM 21
H2094	M2 Shakeproof Washer s.st	6.00 Each	ITEM 30
H2093	M2 Plain Washer s.st.	6.00 Each	ITEM 40
H3095	M3 Plain Washer Nylon	1.00 Each	ITEM 50
W0103	Wire Wrapping Kynar red 30awg	0.01 metre	Link Wire

14.9 Electronic Chassis

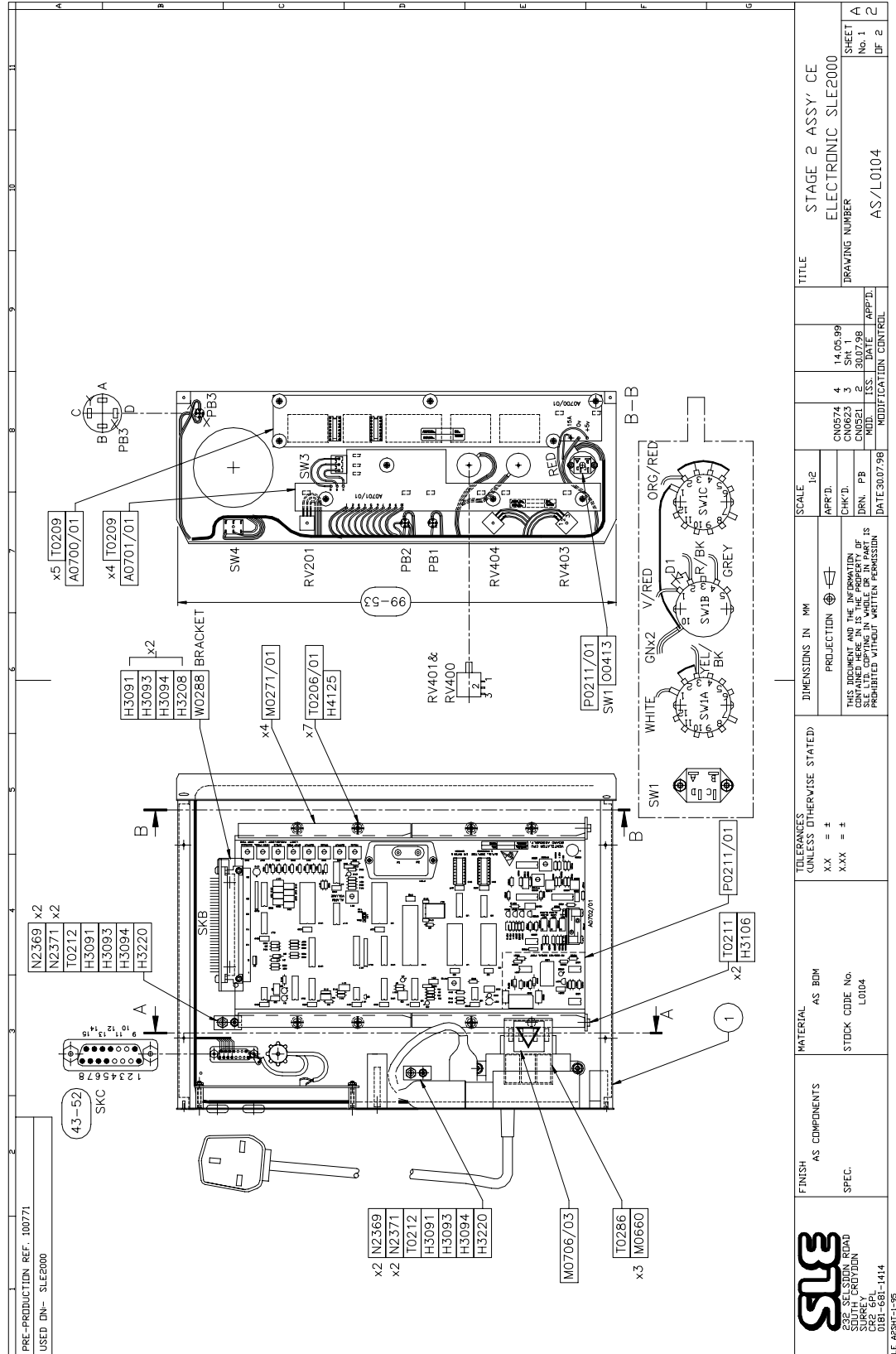

14.9.1 Electronic Chassis

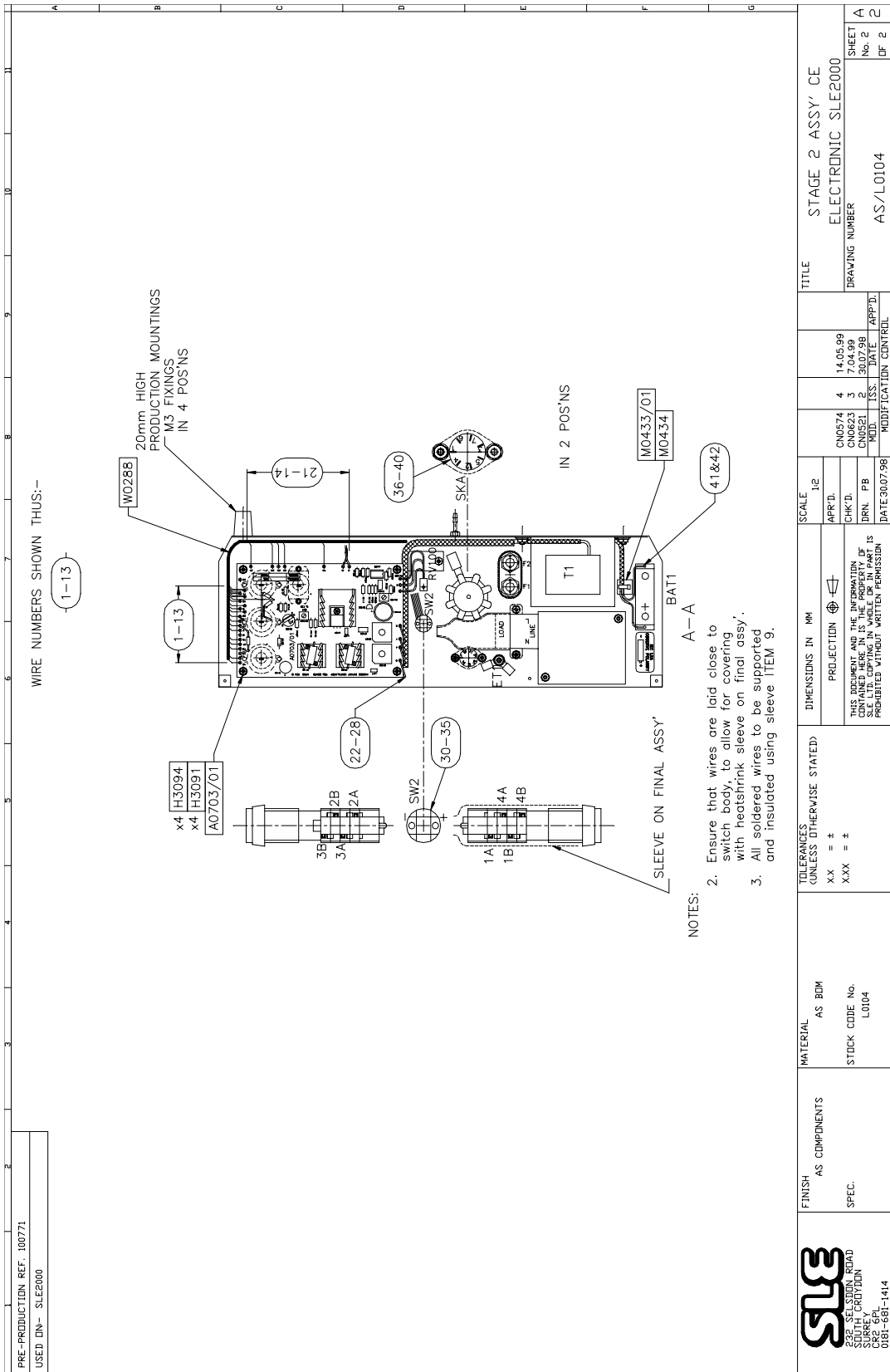

NOTES:

2. Ensure that wires are laid close to switch body, to allow for covering with heatshrink sleeve on final assy.
3. All soldered wires to be supported and insulated using sleeve ITEM 9.

 2322 SELECTION ROAD SOUTH GUYTON CALIFORNIA 95958 0181-561-1414 SLE ASSHT-1-95	FINISH AS COMPONENTS	MATERIAL AS BDM	TOLERANCES UNLESS OTHERWISE STATED) XX = ± XXX = ±	DIMENSIONS IN MM PROJECTION	SCALE 1/2	TITLE STAGE 2 ASSY' CE ELECTRONIC SLEE000	SHEET No. 2 OF 2
	SPEC.	STOCK CODE No. L0104		THIS DRAWING AND THE INFORMATION CONTAINED HEREIN IS THE PROPERTY OF SLE LTD. COPYING IN WHOLE OR IN PART IS PROHIBITED WITHOUT WRITTEN PERMISSION	APR'D. CHK'D. DRN. PB DATE	DRAWING NUMBER AS/L0104	DF 2

PARTS LIST

Finished Item Stock Number L0104
 Finished Item Description 2000 Electronic Assy' Stg2 EMC
 Drawing Number AS/L0104 See Drg File

Part Number	Component Description	Qty Used	Component Reference(s)
L0105	2000 Electronic Assy' Stgl EMC	1 00 Each	ITEM 1
A0700/01	Display Pcb Assembly	1 00 Each	ITEM 2
A0701/01	LED Pcb Assembly	1 00 Each	ITEM 3
A0702/01	Ventilator CPU PCB Assembly	1 00 Each	ITEM 4
A0703/01	PSU Pcb Assembly	1 00 Each	ITEM 5
W0288	Wiring Loom SLE2000 El/tronic	1 00 Each	ITEM 6 Ensure clearance from inner covers
L0104/00	Kit of Assy' Pts 2000 Stg2 EMC	1 00 Each	All other assy' parts

PARTS LIST

Finished Item Stock Number L0104/00
 Finished Item Description Kit of Assy' Pts 2000 Stg2 EMC
 Drawing Number AS/L0104 Issue 4

Part Number	Component Description	Qty Used	Component Reference(s)
D0406	IN4148	1 00 Each	ITEM D1(fitted to SW1)
M0706/03	Label,Hazard Flash (25sq)	1 00 Each	ITEM 7
M0271/01	P C B. Guide Drg 100709	4 00 Each	ITEM 8
M0309/01	H12 x 20mm Sleeve (1 2mm I/D)	60 00 Each	ITEM 9 Use as required
M0433/01	Cable Tie Bases S/A Small	1 00 Each	ITEM 10
M0434	CableATie (Electrical use)	1 00 Each	ITEM 11
M0660	Pad Adhesive double sided	3 00 Each	ITEM 12
N2369	4 5 M5 Hosetail - Male	4 00 Each	ITEM 13
N2371	2661 M5 Washer Nylon	4 00 Each	ITEM 14
00413	Mode Rotary Switch RA3041	1 00 Each	SW1
P0211/01	Shroud for P0234	1 00 Each	ITEM 15
R0602	1k 18 0 5W Resistor MFR4	1 00 Each	Solder to pin 4 on SKA inline wire no 38 cover with heat shrink sleeve
T0206/01	Spacer - aluminium	7 00 Each	ITEM 16
T0206/02	Spacer - Nylon 3/8"OD x 4 5ID	1 00 Each	Replaces ITEM 16 near transformer
T0209	Knurled Thumb Nut Nylon 66	9 00 Each	ITEM 19
T0211	PCB Retainer	2 00 Each	ITEM 20
T0212	Through Connector Block	2 00 Each	ITEM 21
T0286	Transformer shield	1 00 Each	ITEM 22
H3091	M3 Nut Full s st	8 00 Each	ITEM 30



Part Number	Component Description	Qty Used	Component Reference(s)
H3093	M3 Plain Washer s st	4 00 Each	ITEM 31
H3094	M3 S/Proof Washer s st DIN6798	8 00 Each	ITEM 32
H3106	M3 x 6 Pan Hd Pozi s st	2 00 Each	ITEM 33
H3208	M3 x 8 Csk Hd Pozi s st	2 00 Each	ITEM 35
H3220	M3 x 20 Csk Hd Pozi s st	2 00 Each	ITEM 36
H4125	M4 x 25 Pan Hd Pozi s st	8 00 Each	ITEM 38

A vertical, light gray label with rounded corners and a slight shadow, containing the text "A3 circuit Diagram Appendix" in a bold, black, sans-serif font, oriented vertically.

**A3 circuit Diagram
Appendix**



This page is intentionally blank.

PRE-PRODUCTION REF. Rev 15
USED ON- SLE2000

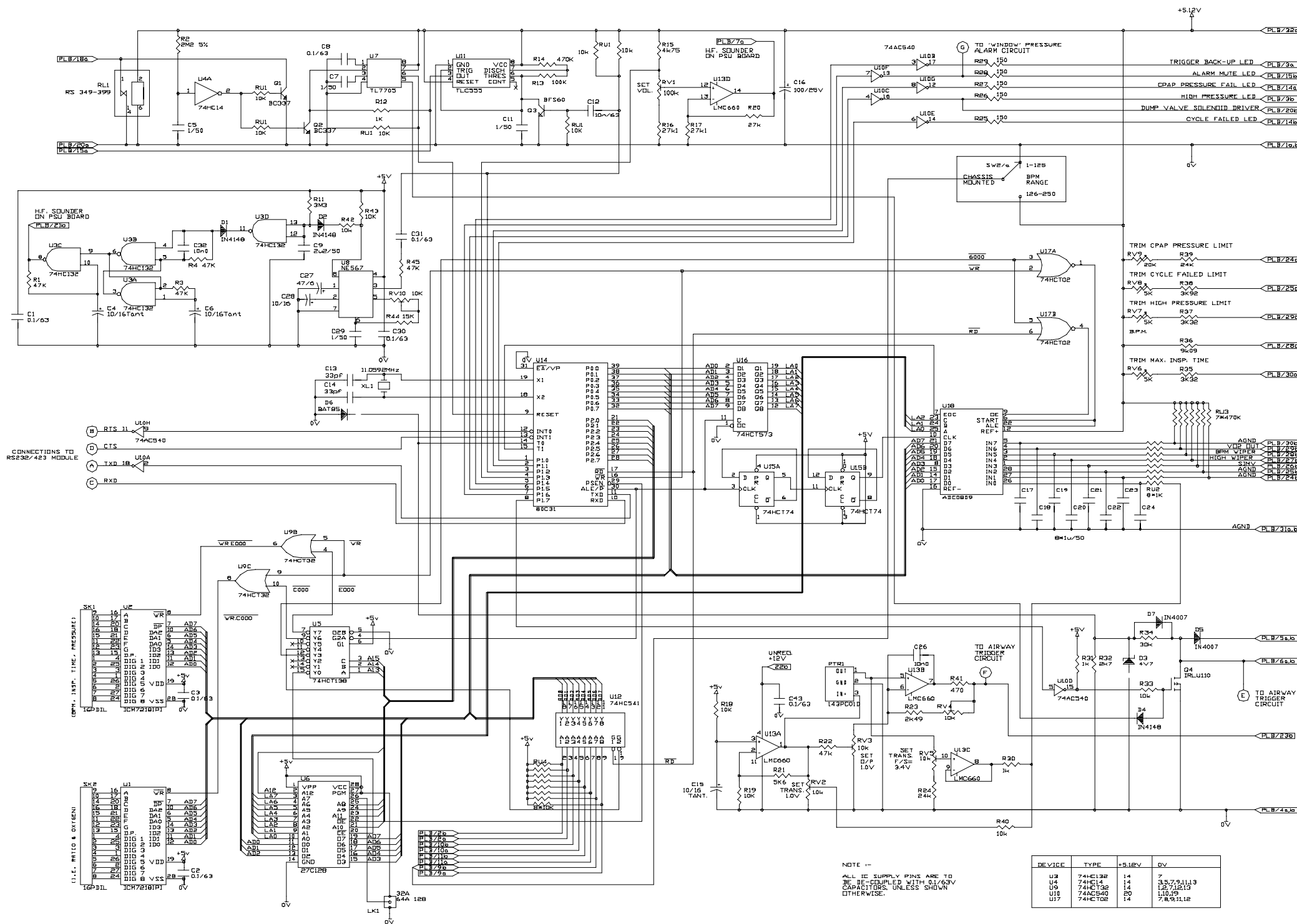

SLE
232 SELSDON ROAD
SOUTH CROYDON
SURREY
CR2 6PL
0181-681-1414

FINISH
SPEC.

MATERIAL
STOCK CODE No.

TOLERANCES
(UNLESS OTHERWISE STATED)
X.X = ±
X.XX = ±

DIMENSIONS IN
PROJECTION

THIS DOCUMENT AND THE INFORMATION CONTAINED HERE IN IS THE PROPERTY OF SLE LTD. COPYING IN WHOLE OR IN PART IS PROHIBITED WITHOUT WRITTEN PERMISSION

SCALE
APR'D.
CHK'D.
DRN. J.G.
DATE 27/7/95

MOD.	ISS.	DATE	APP'D.
CN0626	2	27/4/99	
CN0650	1	10/8/95	

MODIFICATION CONTROL

TITLE
VENTILATOR CPU BOARD

DRAWING NUMBER
CD/A0702/01

SHEET
No. 1
OF 3

A
1

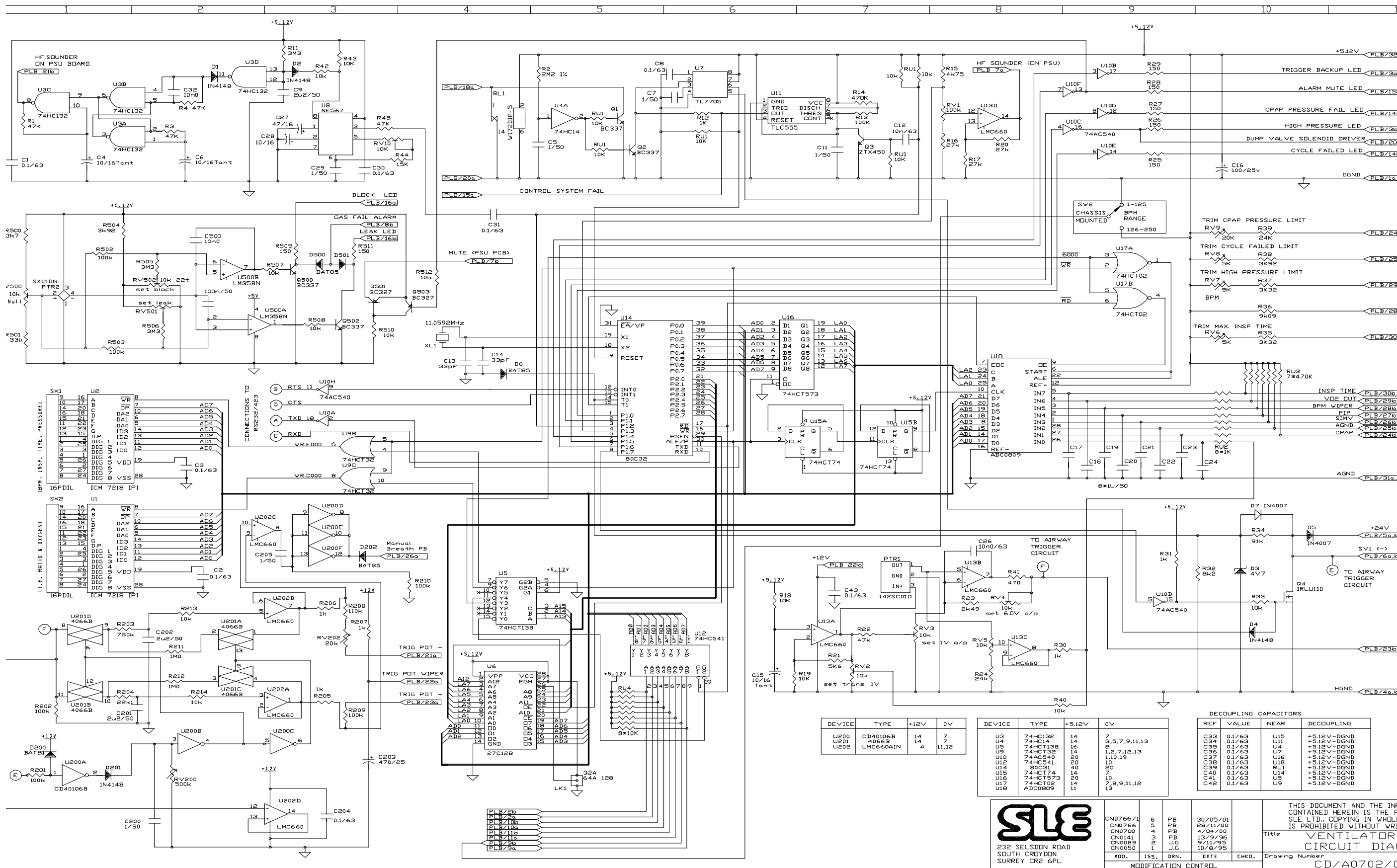

DEVICE	TYPE	+12V	0V
U200	CD40106B	14	7
U201	4066B	14	7
U202	LMC660AIN	4	11,12

DEVICE	TYPE	+5.12V	0V
U3	74HC132	14	7
U4	74HC14	14	8, 9, 5, 7, 9, 11, 13
U5	74HC138	15	8
U9	74HC132	14	1, 2, 7, 12, 13
U10	74AC540	20	1, 10, 19
U12	74HC541	20	1, 10, 19
U14	80C31	40	20
U15	74HC174	14	7
U16	74HC1573	20	10
U17	74HC102	14	7, 8, 9, 11, 12
U18	ABC0809	13	13

DECOUPLING CAPACITORS			
REF	VALUE	NEAR	DECOUPLING
C33	0.1/63	U15	+5.12V-DGND
C34	0.1/63	U1	+5.12V-DGND
C35	0.1/63	U4	+5.12V-DGND
C36	0.1/63	U7	+5.12V-DGND
C37	0.1/63	U16	+5.12V-DGND
C38	0.1/63	U18	+5.12V-DGND
C39	0.1/63	RL1	+5.12V-DGND
C40	0.1/63	U14	+5.12V-DGND
C41	0.1/63	U5	+5.12V-DGND
C42	0.1/63	U9	+5.12V-DGND

SLE
232 SELSDON ROAD
SOUTH CROYDON
SURREY CR2 6PL

MOD.	ISS.	DRN.	DATE	CHKD.	Drawing Number
CN0766/1	6	PB	30/05/01		
CN0766	5	PB	28/11/00		
CN0709	4	PB	4/04/00		
CN0141	3	PB	13/9/96		
CN0809	2	JG	9/11/95		
CN0050	1	JG	10/8/95		

THIS DOCUMENT AND THE INF CONTAINED HEREIN IS THE P SLE LTD., COPYING IN WHOLE IS PROHIBITED WITHOUT WRITING PERMISSION.
VENTILATOR CIRCUIT DIA
CD/A0702/01

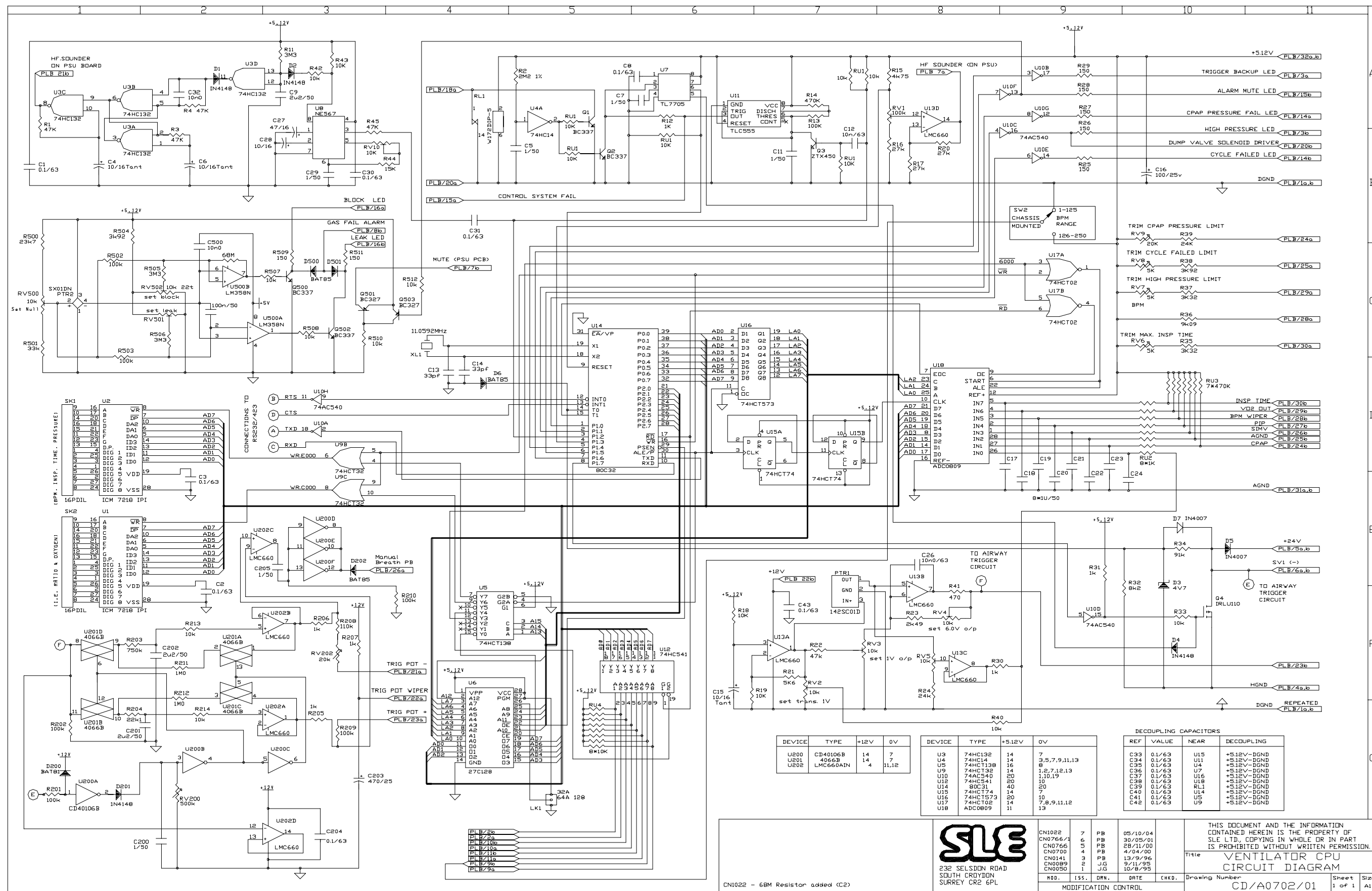

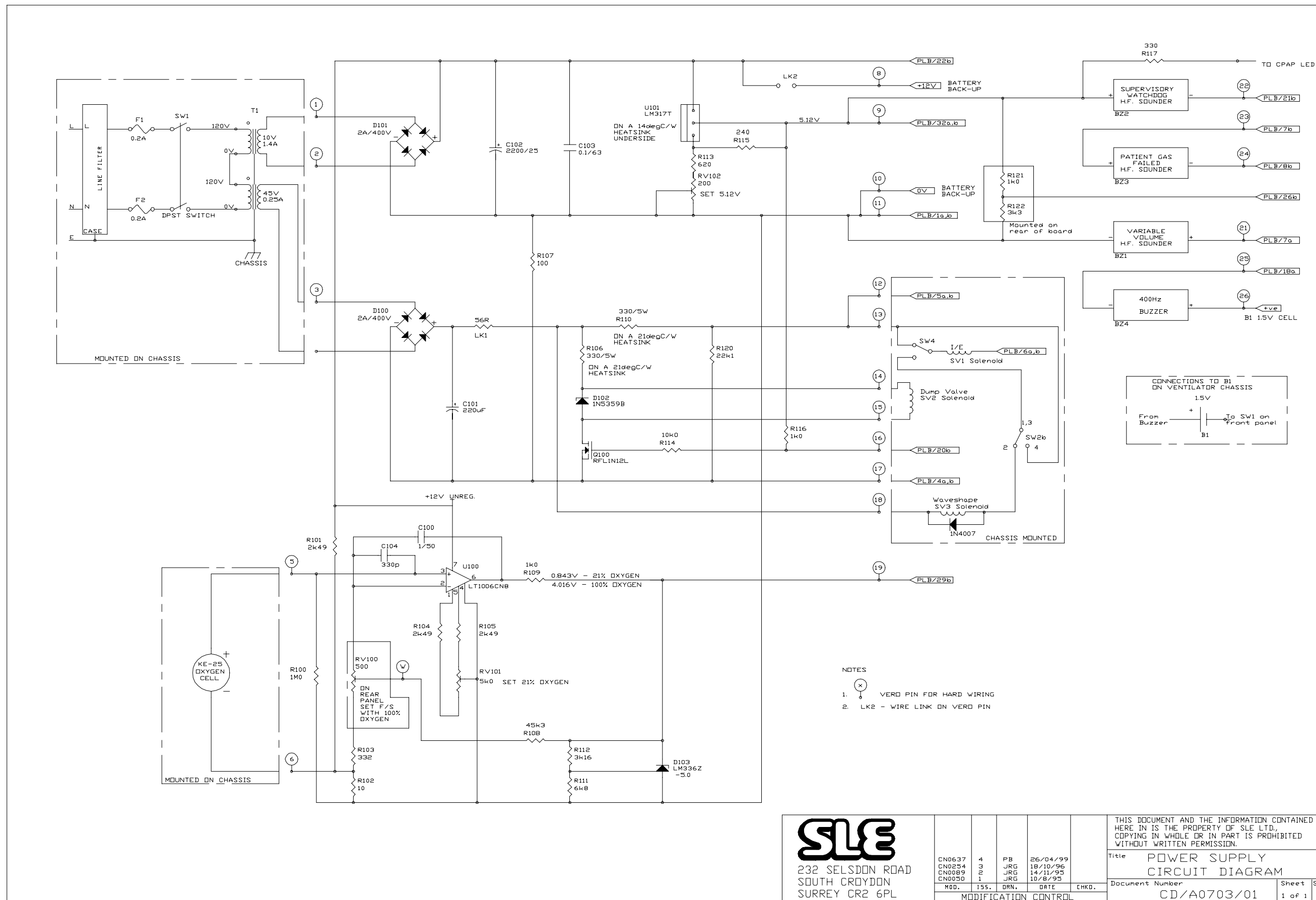

SLE
 232 SELSDON ROAD
 SOUTH CROYDON
 SURREY CR2 6PL

MOD.	ISS.	DRN.	DATE	CHKD.
CN0637	4	FB	26/04/99	
CN0254	3	JRG	18/10/96	
CN0089	2	JRG	14/11/95	
CN0050	1	JRG	10/8/95	

MODIFICATION CONTROL

THIS DOCUMENT AND THE INFORMATION CONTAINED HERE IN IS THE PROPERTY OF SLE LTD., COPYING IN WHOLE OR IN PART IS PROHIBITED WITHOUT WRITTEN PERMISSION.		
Title POWER SUPPLY CIRCUIT DIAGRAM		
Document Number	Sheet	Size
CD/A0703/01	1 of 1	A2

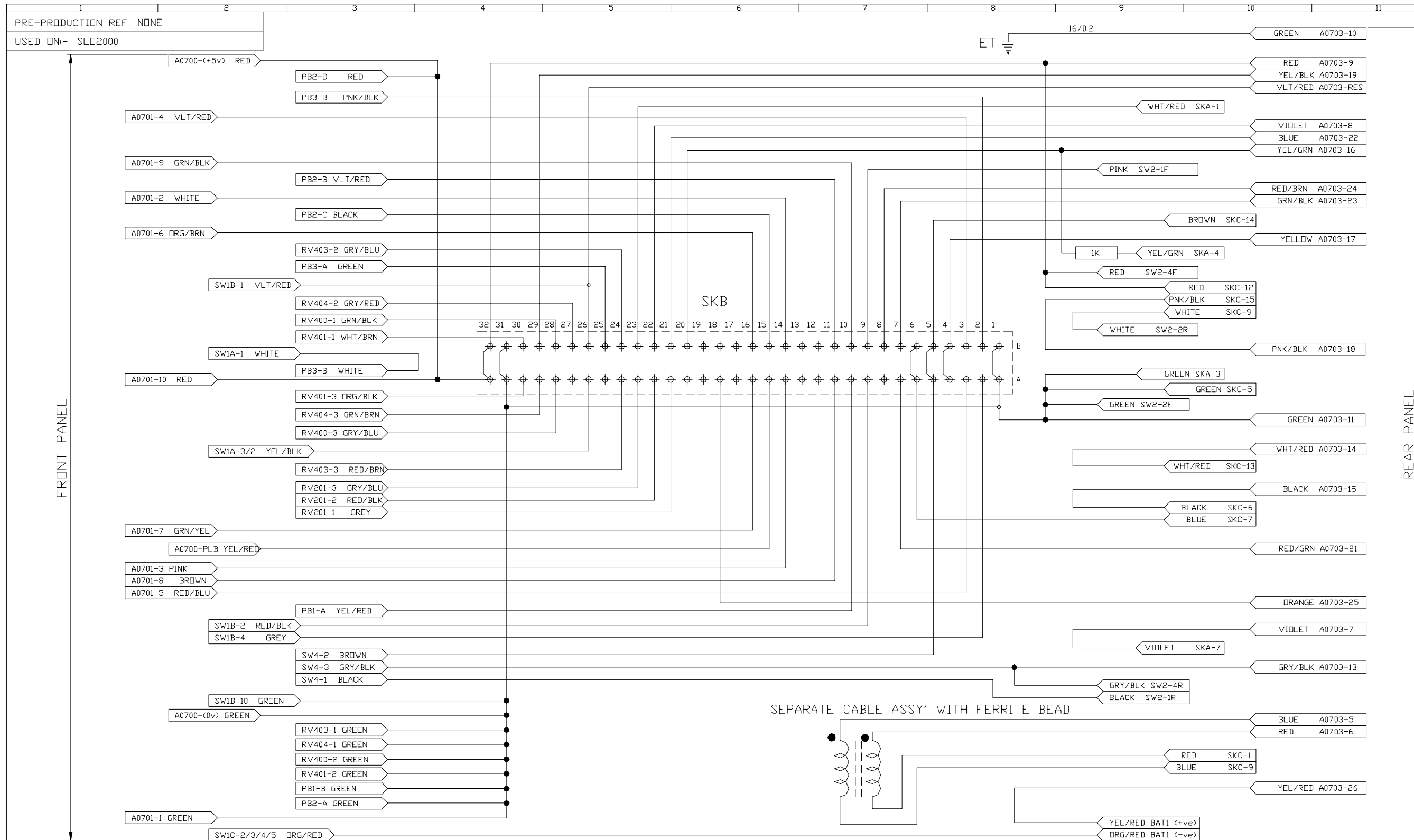

FINISH
SPEC.

MATERIAL
7/0.2 WIRE
EXCEPT WHERE
OTHERWISE STATED
STOCK CODE No.
W0288

TOLERANCES
(UNLESS OTHERWISE STATED)
X.X = ±
X.XX = ±

DIMENSIONS IN
PROJECTION

THIS DOCUMENT AND THE INFORMATION
CONTAINED HERE IN IS THE PROPERTY OF
SLE LTD. COPYING IN WHOLE OR IN PART IS
PROHIBITED WITHOUT WRITTEN PERMISSION

SCALE NTS	DRN. PB	CN0623	1	7.04.99	
APR'D.	CHK'D.	MOD.	ISS.	DATE	APP'D.
DATE 7.04.99					
MODIFICATION CONTROL					

TITLE WIRING LOOM SLE2000 ELECTRONIC	DRAWING NUMBER CD/W0288	SHEET No. 1 OF 1
--	----------------------------	------------------------

**Service Information
and Technical Bulletins**



16. Service Information and Technical bulletins

The following are all the current Service Information and Technical Bulletins that have been issued for the SLE 2000 ventilator.

Service Information Letters (see page 113)

SI 980301 Ventilator Alarms and INOSYS Nitric Oxide Delivery System

SI 980302 Ventilator oxygen cells (N2191)

SI 990302 Possible inadvertant solenoid failure messages

SI 000201 Leak Alarm Trigger Threshold.

SI 020901 Cleaning, Disinfection and Sterilisation of SLE ventilators.

SI 031101 N2183 0-4 bar pressure gauge.

Technical Bulletins (see page 121)

TB 990603 Removal of hour counter from electrical chassis.

TB 000201 New versions of control software.

TB 000801 Ventilator firmware history.

TB 040301 SLE2000 CPU Boards.

TB 040401 V0226 Potentiometer

16.1 Service Information

16.1.1 SI 980301 Ventilator Alarms and INOSYS Nitric Oxide Delivery System

Subject:	Ventilator Alarms and INOSYS Nitric Oxide Delivery System
Equipment:	2000 and 2000 HFO Infant Ventilators
Serial Numbers:	All
Service Information Number:	SI 980301
Change Note Ref:	CN 0521
Date:	27 May 1998

The INOSYS Nitric Oxide Delivery System has the ability to accept an alarm signal from the ventilator it is being used with, in the event of a leak being detected in the patient circuit. This will shut off the supply of NO to the flowmeters and hence to the patient. This signal is connected via a rear panel 3 pin Din connector. The signal levels required are TTL compatible, active low. i.e. +5 volts = valve open. 0 volts = valve closed.

The following modifications are required to the SLE 2000 and 2000 HFO Infant Ventilators, if you wish to feed an alarm signal to the INOSYS unit to cut off the supply of NO gas to the patient in the event of a fresh gas supply reduction, due to a high alarm condition or ventilator failure.

2000 Infant Ventilator:-

Connect a wire from pin 16 of the Power Supply Board A0703 via a 1k_0 .25 watt resistor to the spare pin 4 on the rear panel auxiliary output connector (7 Pin DIN). The resistor should be connected directly to pin 4 and then sleeved with heatshrink sleeving. The wire should follow the run of the existing cable loom, using cable ties to hold it in place.

2000 HFO Infant Ventilator:-

Connect a wire from PLB/pin 3 of the A0702 board to the spare pin 4 on the rear panel auxiliary output connector (7 Pin DIN). This wire should follow the run of the existing cable loom using, cable ties to hold it in place.

Note: A resistor is not required on the 2000 HFO as the alarm signal comes from a buffer output.



Connecting Cable:-

A connecting cable will be required to connect the INOSYS and the Ventilator together and this should be made up using a screened lead with the following pin connections :

3 Pin plug INOSYS

7 Pin plug Ventilator

Pin 1 (alarm signal)

Pin 4 (alarm signal)

Pin 2 (0 Volts)screen

Pin 3 (0 Volts)screen

All other pins must be left unconnected.

IMPORTANT:

Ventilators and INOSYS units must be checked to verify correct operation after this modification has been carried out. See the appropriate user manuals for these procedures.

16.1.2 SI 980302 Ventilator oxygen cells (N2191)

Subject:	Ventilator oxygen cells (N2191)
Equipment:	2000 and 2000 HFO Infant Ventilators
Serial Numbers:	All
Service Information Number:	SI 980302
Change Note Ref:	N/A
Date:	16 March 1998

The oxygen cells in the ventilators are fitted with an adhesive foam pad between the sensor and the baseplate. This pad has, until now, been stuck to the mounting base in the ventilator. This means that the pad does not get replaced when the oxygen cell is replaced. Over a number of replacements of the oxygen cell, the foam pad will compress and not be so effective at holding the cell in place.

New cells fitted to ventilators and replacement spares will now be provided with the foam pad stuck to the base of them. This means that when the cell is replaced, the foam pad is also replaced.

When fitting replacement cells it is now necessary to remove the old pad from the mounting base first so the new cell with the pad stuck to the bottom can be accommodated.

Note: Do not fit an oxygen cell without the foam pad.



16.1.3 SI 990302 Possible inadvertant solenoid failure messages

(80C31/32 Microcontroller logical 1 to 0 transition currents on port 3)

Subject: Possible inadvertant solenoid failure messages (80C31/32 Microcontroller logical 1 to 0 transition currents on port 3)
Equipment: SLE 2000, SLE2000HFO, SLE2000HFO 'PLUS' (A0702 boards - all variants)
Serial Numbers: All ventilators prior to serial number starting 904 (April 99)
Service Information Number: SI 990302
Change Note Ref: CN 0626
Date: 2 March, 1999

Introduction

Recently it has been found that some makes of microcontrollers produce a solenoid failure message when used on HFO ventilators. This is because the solenoid failure detection circuit connected to one of the controller inputs does not adequately pull the input to zero (The 80C32 sources a 1 to 0 transition current of 650mA at 2V). For a similar reason it is necessary to change the solenoid failure detection circuit for an SLE2000 Ventilator. Modification procedure for A0702 boards on the SLE ventilators.

Connect a diode (1N4007) in parallel with R34 with its cathode (+ve) connected to the drain of Q4(IRLU110) on all A0702 boards.

Additionally, if the ventilator is an SLE2000 then change R32 to 8k2 and R34 to 91k. (0.25W 1% Metal Film)

Rationale: The diode will be reverse biased when Q4 is turned off. When Q4 is turned on it has a value of Rds of 0.5W, giving a Vds of <0.1v. The diode voltage is added to this which shall result in the microcontroller i/p being pulled down to <0.8v.

Circuit Diagram changes

SLE 2000 changes

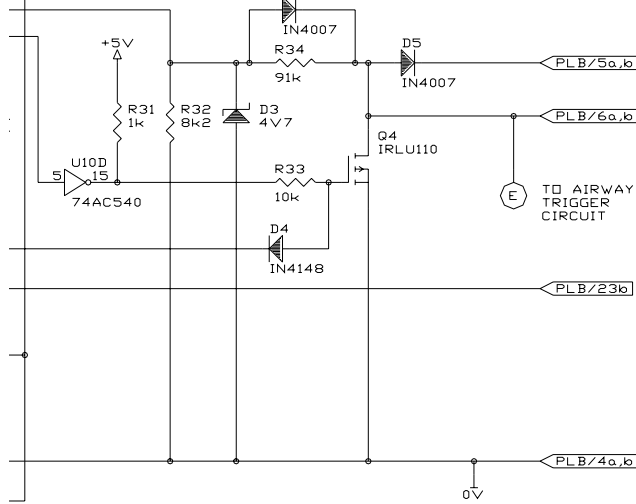

SLE 2000 HFO & HFO 'plus' Changes

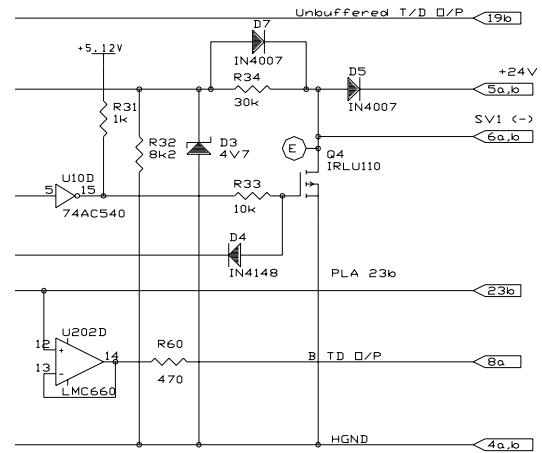



16.1.4 SI 000201 Leak Alarm Trigger Threshold.

Subject: Leak Alarm Trigger Threshold.
Equipment: 2000, 2000HFO & 2000HF0+ Ventilators
Serial Numbers: All
Service information Number: SI 000201
Change Note Ref: CN 700
Date: 10/02/2000

Introduction

It has been notice during final test on some ventilators, that the leak alarm trigger threshold is unstable causing the leak alarm "LED" to flicker and the alarm sound to be intermittent.

This is unlikely to be problem in normal use, as the pressures in the patient circuit are not stable enough to cause this condition to be seen. However as a precaution a 100nf capacitor has been added across the input of U500A Pins 2 & 3 on the A0702 Board.

See photograph and circuit diagram on next page.

This capacitor is being added as standard to all new production and it is recommended that this modification should be carried out during routine servicing.

The capacitor used is a 100nf multilayer palladium/ceramic type and can be order from SLE using part N°: C0481. Alternatively it can be ordered from your local component supply using the Philips part N°: CW20C 104M

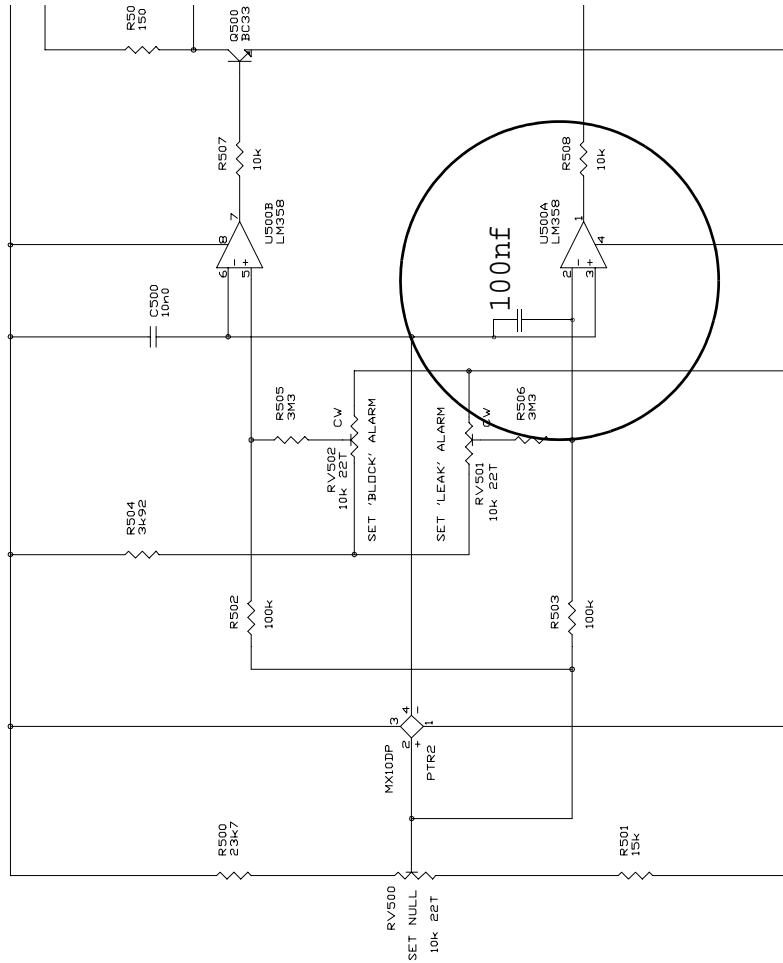

- NOTES 1"
1. ALL 'PDT'S' ARE 'SERNICE TYPE T93YA 10K 10% 22 TURN.
 2. 'AUDIBLE ALARM' IS 'PATIENT GAS FAILED HF. SOUNDER' ON PSU BOARD.

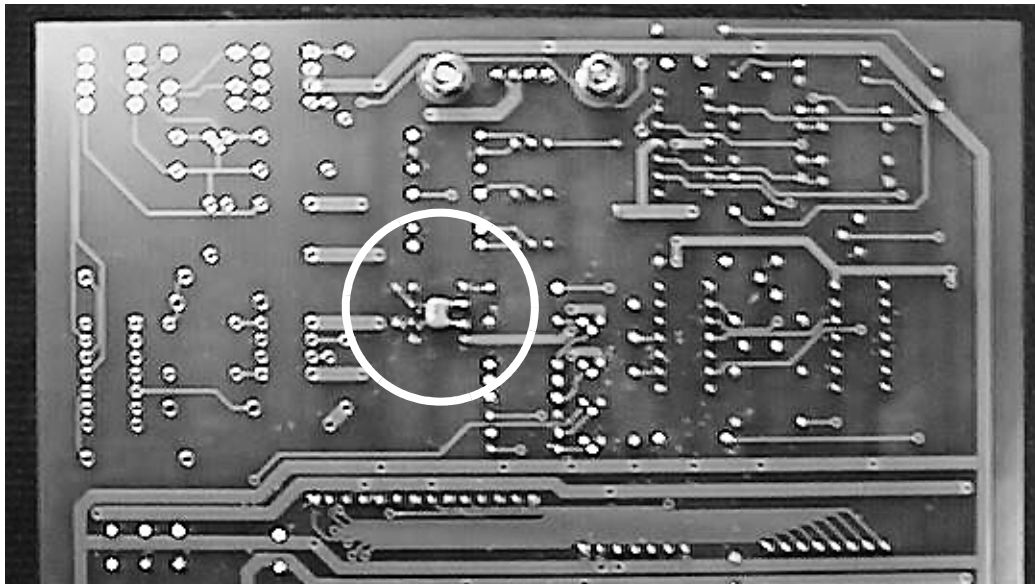



16.1.5 SI 020901 Cleaning, Disinfection and Sterilisation of SLE ventilators.

Subject: Cleaning, Disinfection and Sterilisation of SLE ventilators.
Equipment: SLE 2000, SLE2000 HFO, SLE2000 HFO Plus
Serial Numbers: All
Service information Number: SI020901
Date: 24/09/2002

Introduction

The MDA has issued a safety notice SN 2001(28) "Compatibility of medical devices and reprocessing equipment with Decontamination agents," which states that manufactures of medical devices should state decontamination agents that are compatible with there products.

The following is an extract from Medical Devices Agency safety notice SN 2001(28)

The Medical Devices Agency continues to receive reports about damage to medical devices or their components and to reprocessing equipment following contact with incompatible decontamination agents.

The damage is usually the result of reactions between the decontamination agent and the materials of construction of the device or reprocessing unit. Such damage may affect the performance or functionality of the device or the effectiveness of the decontamination procedure.

Manufacturers of reusable medical devices are required to provide information on how to decontaminate their devices. This information should include the types of decontamination agent that may be used, together with a warning of any agents or processes that are known to be detrimental to the device.

Due to SN 2001(28) we are issuing more detailed guidelines for the Cleaning, Disinfection and Sterilisation of our products, to be used in conjunction with those already in the user manuals.

Cleaning, Disinfection and Sterilisation Guidelines.

We recommend the following agents:

Ventilator outer casings and pole: Liquid cleaner or detergent. (As recommended by an appropriate hospital authority).

Do not use any strong solvent cleaners on the front panels or labels.

Main and rotating jets: 70% Isopropranol alcohol (AZO wipes).

Do not use Haz Tab on the main and rotating jet or manifold as this may cause corrosion over time.

Exhalation block: Standard autoclave at a 134 degrees Celsius for 3 minutes or at 121 degrees Celsius for 20 minutes. No limit to number of autoclave cycles

Measures to prevent contamination of SLE ventilators whilst in use.

We recommend that in line bacterial filters are used between the patient circuit and the exhalation block and the fresh gas port and humidifier supply line. We also recommend that single use patient circuits are used where possible.

16.1.6 SI 031101 N2183 0-4 bar pressure gauge

Subject: N2183 0-4 bar pressure gauge.
Equipment: SLE2000
Service information Number: SI031101
Date: 23/09/03

Introduction

The purpose of this service information letter is to inform users of the SLE2000 infant ventilator that there is an alternative N2183 (0-4 bar) pressure gauge.

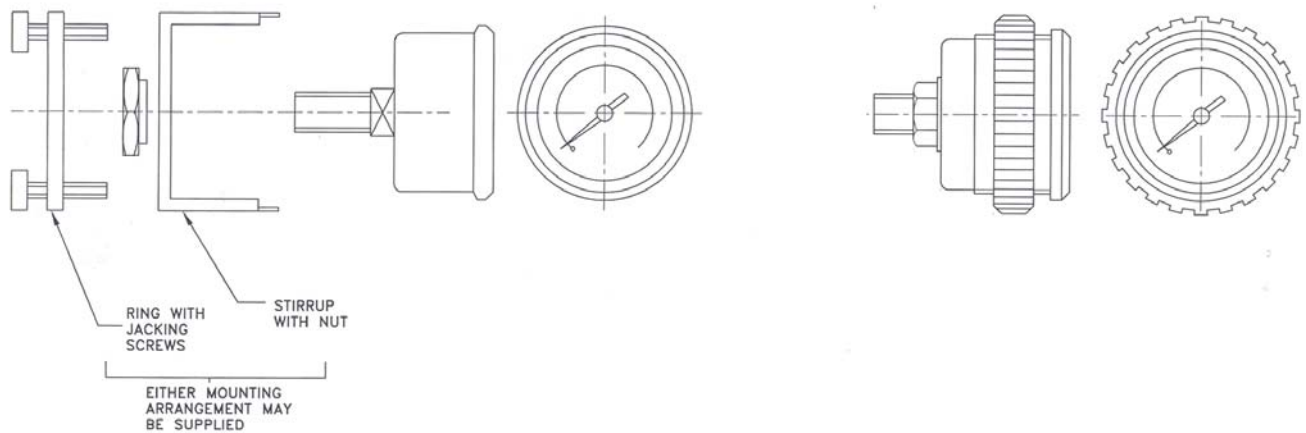

Existing gauge

Alternative gauge

The alternative gauge utilizes a threaded locking ring to fix the gauge to the front panel. The new and old styles of gauges are interchangeable.



16.2 Technical Bulletins

16.2.1 TB 990603 Removal of hour counter from electrical chassis.

Subject:	Removal of hour counter from electrical chassis.
Equipment:	SLE Ventilators
Model:	SLE 2000 & SLE 2000 HFO
Technical Bulletin Number:	TB 990603
Change Note Ref.:	CN 0574
Date:	03 June 1999

This bulletin has been raised due to a design change. The change being the removal of a duplicated hour counter from the electronic chassis of SLE 2000 and SLE 2000 HFO ventilators.

The change is to be phased in and some new ventilators will still have two hour counters. This will cease when stocks of the old chassis have been exhausted.

Existing ventilators do not require modification to remove the duplicated hour counter.

The one hour counter, will be located in the pneumatic chassis. This is the unit that is subject to the most wear and tear and requires a major overhaul at 10,000 hours, so it is important that we record the running time of these chassis. The power consumption of the hours counters is very small, so removal of one will not affect the overall power rating of the ventilator.

16.2.2 TB 000201 New versions of control software.

Subject: New versions of control software.
Equipment: SLE 2000, SLE 2000 HFO and SLE 2000 HFO+ Ventilators.
Serial Numbers: All
Technical Bulletin Number: TB 000201
Change Note Ref: CN 0616
Date: 11/02/2000

Introduction

Removal of audible bleep in patient triggered modes

Following customer feedback, the control software on the above range of ventilators has been changed. In the new version the audible bleep, in PTV and SIMV modes is suppressed for machine triggered breaths. Breaths are still indicated by the trigger back up LED illuminating. If required the audible bleep can be re-instated by holding in the reset button when powering up the ventilator.

The above feature is available from the following software versions

Ventilator	Software Version
SLE 2000	V3.3
SLE 2000 HFO	V1.103
SLE 2000 HFO+	V1.18



16.2.3 TB 000801 Ventilator Firmware Status

Subject: Ventilator Firmware Status.
Equipment: SLE 2000, SLE 2000 HFO & SLE 2000 HFO PLUS
Serial Numbers: All
Technical Bulletin Number: TB 000801
Change Note Ref: N/A
Date: 08/09/00

Introduction

The purpose of this technical bulletin is to provide information on the control and display versions of firmware available for the SLE 2000, SLE 2000 HFO and SLE 2000HFO Plus ventilators.

SLE 2000

Control firmware.

Firmware version	Date of change	Change note N°	Details of change.
V3.0	09/03/93		Includes "Mary interface" and runs on a 80C32 processor. For ventilators fitted with serial port.
V3.1	17/06/94		Changed I/E Ratio display from flashing to non-flashing hyphens if ratio <1:9.9 or > 9.9:1.
V3.3	15/01/99	CN0616	No audible indication of machine triggered breaths in patient triggered modes (SIMV and PTV) unless reset button is held in during power up.

SLE 2000 HFO

Control firmware.

Firmware version	Date of change	Change note N°	Details of change.
V1.09	09/03/93		Flashing of I/E Ratio display replaced with hyphens to indicate out of limit values.
V1.10	17/06/94	CN0078	Airway pressure signal conditioner ranging modified to give RV2(zero) and RV5 (span) greater travel.
V1.103	15/01/99	CN0616	Removal of the audible indication of machine triggered breaths in patient triggered modes (SIMV and PTV).
V1.11	22/10/99	CN0676	Change to the averaging period of the mean calculation to 4 seconds. Watchdog servicing time changed from 350ms to 20ms.

V1.12	01/09/00	CN0729	Quantisation error correction in CMV mean calculation.
-------	----------	--------	--

Display firmware.

Firmware version	Date of change	Change note N°	Details of change.
V1.0	17/01/95		Initial release
V1.1	07/02/95		Adjustment of the offset on the HFO rate display by 2Hz., to allow for setting of the HFO rate circuit without saturation at the top end.
V1.2	08/06/95	CN0056	Correction of error in Fail to Cycle detection algorithm which caused spurious triggering of Fail to Cycle alarm. Increased debouncing on "Freeze" push button. Correction of graphic display that did not update when the ventilator is switched on with the display rate switch position in 0.5sec setting.
V1.3	26/07/95	CN0063	Modification to prevent the screen going blank when subject to 8KV ES discharge.
V1.4	20/12/95	CN0099	Correction of error in Fail to Cycle detection which caused erroneous triggering at low pressures.
V1.5	26/03/96	CN0116	Delta P to be displayed for CPAP and HFO modes and ident on oscillator pressure gauge changed.
V1.6	10/07/96	CN0156	Increased range of display of delta pressures. Addition of display of pressure transducer saturation (positive and negative).
V1.7	30/04/97	CN0308	Implementation of an HFO disconnection alarm and pressure transducer drift alarm.
V1.8	15/05/97	CN0362	Modification of High alarm level (minimum setting). Update of SLE logo. Addition of conditional assembly directives for french version.
V1.9	18/11/97	CN0428 CN0449	Inclusion of display firmware in German. Change in method of setting the Delta P alarm.
V2.0	18/03/98	CN0495	Modification of the pressure transducer drift detection algorithm.



V2.1	26/02/99	CN0632	Inclusion of O ₂ alarm. High Delta P converted to alarm condition. Delta P to be set as a percentage rather than a fixed window. Reduction of the response time of the Delta P alarm.
------	----------	--------	--

SLE 2000 HFO PLUS

Control firmware.

Firmware version	Date of change	Change note N°	Details of change.
V1.17	02/10/98		Indication of delivery of a machine breath changed from audible to visual in spontaneous period of SIMV mode.
V1.18	28/06/99	CN0616	Removal of the audible indication of machine triggered breaths in patient triggered modes (SIMV and PTV).
V1.20	22/10/99	CN0676	Change to the averaging period of the mean calculation to 4 seconds. Watchdog servicing time changed from 350ms to 20ms.

Display firmware.

Firmware version	Date of change	Change note N°	Details of change.
V1.0	30/09/98	CN0560	Initial release.
V1.1	08/12/98	CN0589	Removal of mean pressure drop alarm. High delta P converted to alarm condition.
V1.2	12/02/98	CN0608	The response time of the delta P alarm decreased at slower screen update rates.

16.2.4 TB 040301 SLE2000 CPU Boards

Subject: SLE2000 CPU Boards
Equipment: SLE2000 Infant ventilators
Units affected: E0108 & Y0963 to Y0975
Technical Bulletin Number: TB 040301
Date: 17/03/2004

Introduction

Following an investigation as part of our testing programme we have discovered that the most recent batch of SLE2000 CPU boards contains an error that is not immediately obvious through normal functional testing. A batch of these boards has been assembled where the IN4148 signal diodes have been mistakenly swapped with the Schottkey BAT85 diodes (4 off of each).

Although the circuit may appear to work the electrical characteristics for these devices is fundamentally different and will result in different circuit protection and operating times.

The diodes therefore will need to be correctly placed in the boards which you have been supplied (i.e. batch no.7763/06 nos. 01-25)

All the boards in the affected batch must be traced and new devices correctly fitted as follows:

IN4148 ; refs D1, D2, D4, D201
BAT85 ; refs D6, D202, D500, D501

Note: Need to be careful to ensure that any further potential error is not brought about by further changes to D200 which is a BAT81 and is currently fitted correctly.

Once these have been replaced it is recommended that a full functional test is carried out to ensure that all alarms and LEDS operate (i.e. the major area where the correct diodes have an impact).

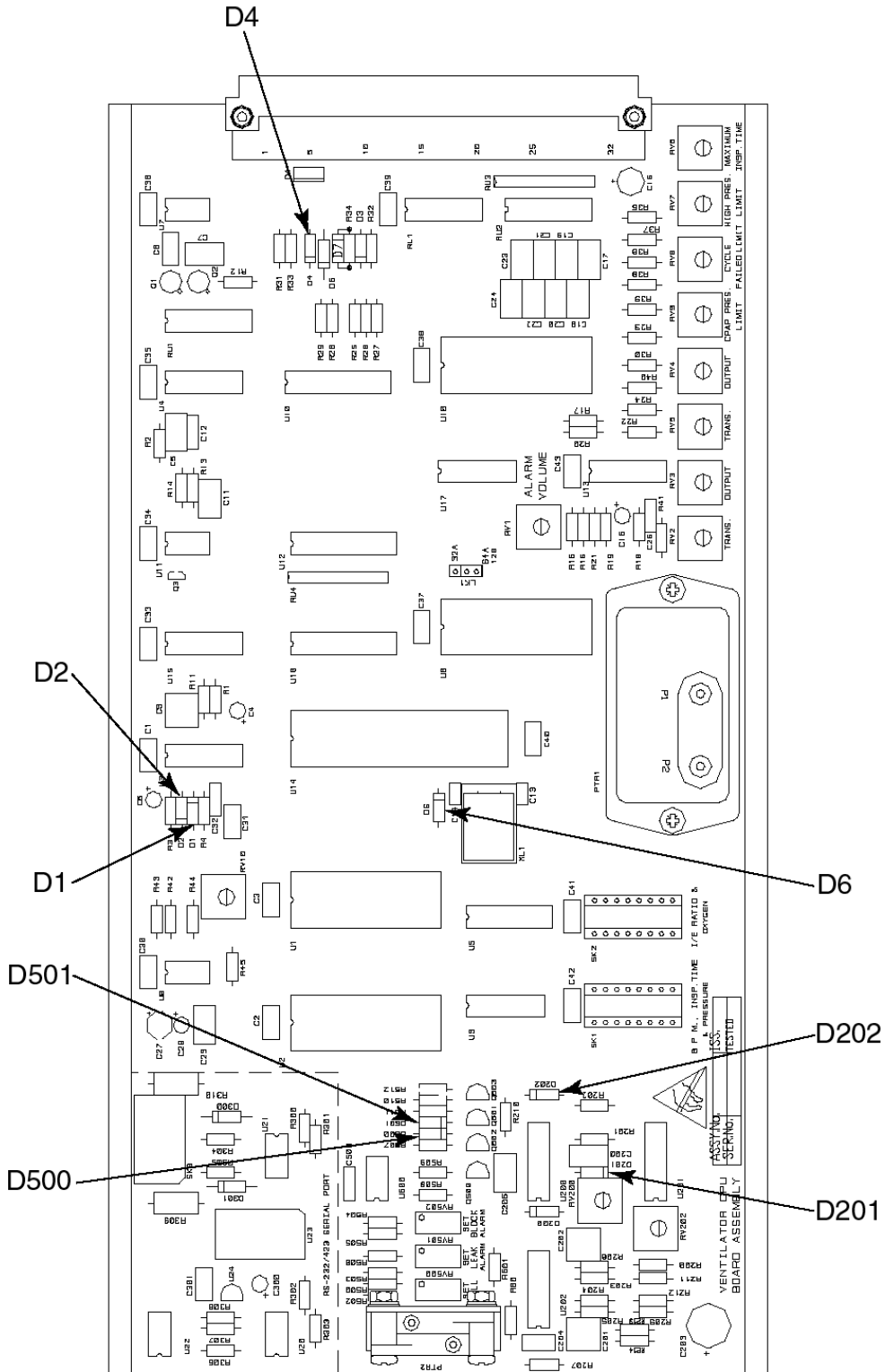

16.2.5 TB 040401 V0226 Potentiometer

Subject: V0226 Potentiometer
Equipment: SLE2000, SLE2000 HFO & SLE2000 HFO+ Infant ventilators
Units affected: Units manufactured after March 2004
Technical Bulletin Number: TB 040401
Change Note Ref: CN 0983
Date: 05/04/2004

Introduction

This technical bulletin is to inform the users of the SLE2000, SLE2000 HFO & SLE2000 HFO+ Infant ventilators that the design of the V0226 potentiometer has changed.

The potentiometer has changed from a Spectrol 149SXX48S103SP to a Spectrol 149SXX40S103SP.



149SXX48S103SP



149SXX40S103SP

The change in design requires that the 149SXX40S103SP is fitted with two shake proof washer between the body and the front panel.

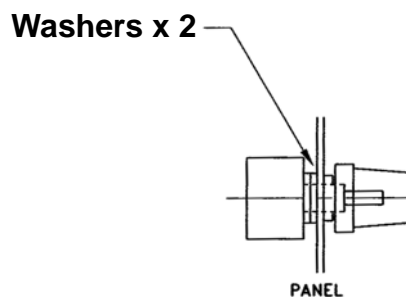



17. Issue Revision Record

Issue 1: CN0533 (incorporating CN0345, CN0357).
Issue 2: CN0623, CN0626, CN0637 & CN0642.
Issue 3: CN0700
Issue 4: CN0720
Issue 5: CN0766
Issue 6: CN0805
Issue 7: CN1001, CN1005 & CN1022

18. Index

Numerics

80C31 microcontroller.....	39
A	
ADC	39, 41
Air and Oxygen Supply Failure Alarm test.....	34
Airway Trigger Calibration.....	43
Alarm Volume	42
B	
Battery.....	59
Battery condition and LED display test.	34
BPM	13, 34, 39, 43, 45
C	
Cleaning prior to first use	30
Cleaning when in service	30
CPAP	51, 58
CPAP Alarm Set Point Control.....	42
CPU Board.....	68
D	
Dismantling Procedure for ventilator.....	22
Display Board (A0700).....	62, 64
E	
Electronic Chassis	95
Electronic Module	
Calibration Procedure.....	41
Description of Operation.....	39
Troubleshooting Chart	45
EPR0M.....	39
Exhalation block.....	56
F	
FIO ₂	13, 34, 43, 55
Fresh Gas Block and leak Alarm	43
Front Panel	16, 19, 20
G	
Glossary.....	13
I	
IE Ratio	13
Inspiration Time	13, 42
Inspiratory Nozzle testing.....	34
L	
LED Board (A0701).....	39, 65, 67
M	
Module Separation, how to	24
Monthly Operational Checks.....	34



O

Operating Modes	58
Conventional Ventilation	58
Overhaul	35
Oxygen Blender removal	25
Oxygen cell	26

P

Patient Triggered Ventilation (PTV)	13, 18, 44
PIP Control.....	42
Pneumatic Module	
Calibration Procedure	51
Circuit Diagram.....	52
CPAP System.....	49
Description of Operation.....	46
Fresh Gas System.....	48
Parts List.....	53
Troubleshooting Chart	55
Preventative Maintenance	35
PSU Board (A0703)	45, 90
PTR	
Pressure Transducer	40
PTV sensitivity	58

R

RS232/423	88
-----------------	----

S

Serial Interface.....	89
Service Information	112
SI 000201.....	118
SI 020901.....	120
SI 03110.....	121
SI 980301.....	113
SI 980302.....	115
SI 990302.....	116
SLE2000 HFO	
Controls	59
Displays	58
Software.....	39, 40
Symbols	12
Synchronous Intermittant Mandatory Ventilation (SIMV)	13, 18

T

TB 000201	123
TB 000801	124
TB 040301	127
TB 040401	129
TB 990603	122
Technical bulletins	112

Technical Specification	58
Test for Condition of O ₂ Cell	34
Test for Proximal Airway Pressure Gauge Accuracy	34
Trigger back-up	39
V	
Ventilator CPU Board (A0702)	45, 69, 76, 81, 89
W	
Watchdog alarm	40
Wireloom	94



This page is intentionally blank.



SLE reserves the right to make changes without prior notice in equipment, publications and prices as may be deemed necessary or desirable.



SLE Limited
Twin Bridges Business Park
232 Selsdon Road
South Croydon
Surrey CR2 6PL UK

☎ +44(0)20 8681 1414 ✉ sales@sle.co.uk
📠 +44(0)20 8649 8570 🌐 www.sle.co.uk