

Dräger

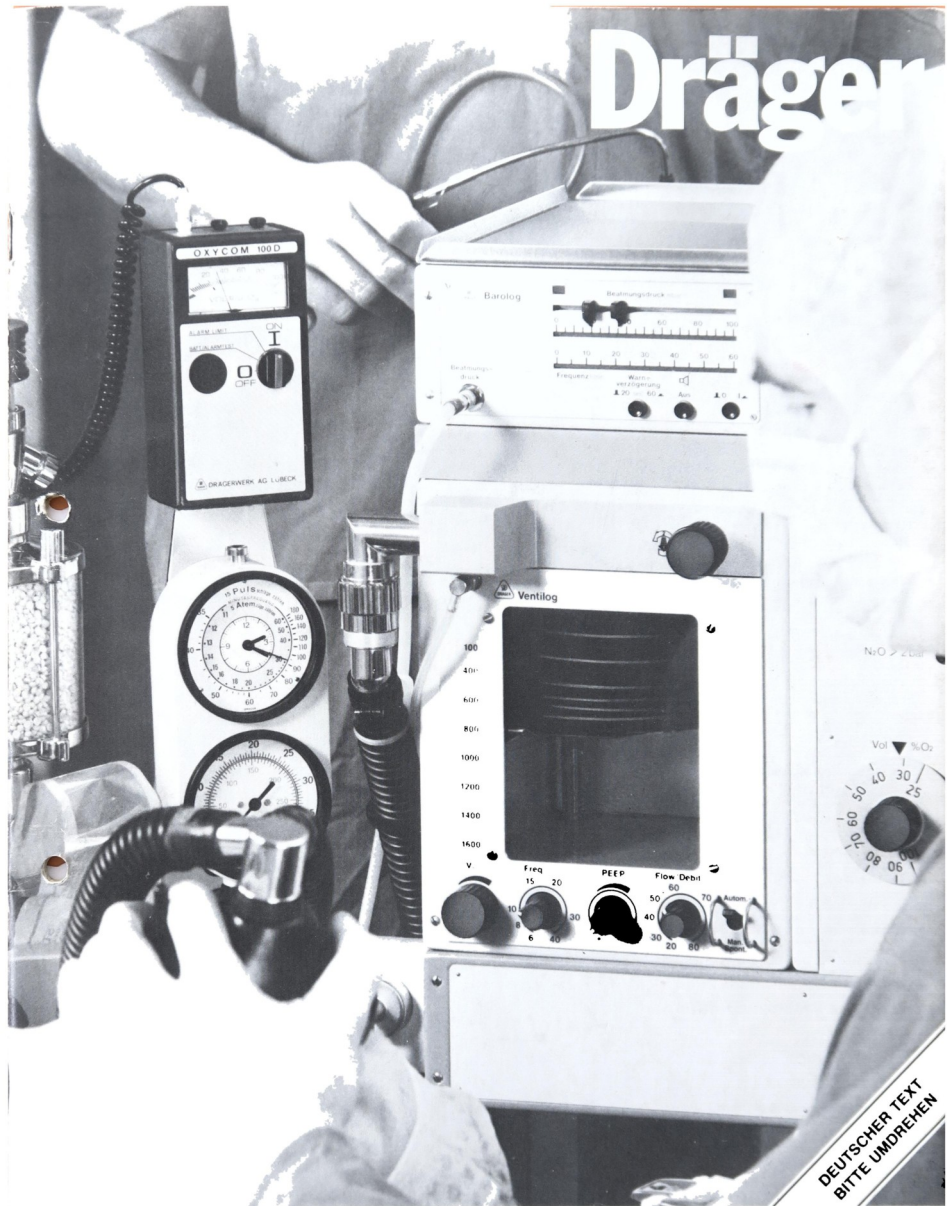

DEUTSCHER TEXT
BITTE UMDREHEN

OPERATING MANUAL

Ventilog[®] Anaesthetic Ventilator

From Dräger: Ventilog[®] Anaesthetic Ventilator

OPERATING INSTRUCTIONS

Important Notice

For correct and effective use of the device, and to avoid hazards, we would point out the following:

- 1 Any use of the device requires precise knowledge and observation of these operating instructions.
- 2 The device is intended only for the purposes specified in the Operating Manual or for purposes confirmed in writing by Drägerwerk AG.
- 3 The device should be inspected by experts at regular time intervals. An official report of the inspections should be drawn up.
- 4 Only original Dräger spare parts should be used for maintenance and repairs.

Repairs and maintenance, and the replacement of spare parts should only be carried out by experts.

- 5 We recommend having inspections and repair work carried out by the Technical Customer Service of your Dräger Branch or Agent. Regular inspection is best ensured by entering into an Inspection Service Contract with the Technical Customer Service of your Dräger Branch or Agent.
- 6 Responsibility for the reliable function of the device passes to the owner or operator in all cases where the device has been inexpertly maintained or

repaired by persons not employed by the Dräger Organization or where it has been used in a manner which does not conform to the normal conditions of use.

- 7 For reasons of safety, pressure reducers should be overhauled at least every 6 years.
- 8 This device must not be used in areas with danger of explosion.

We would also point out that the national recommendations, regulations and laws governing the use of technical equipment should be observed.

DRÄGERWERK AG LÜBECK

Contents

	Page
Important Notice	2
Applications	3
Technical Data	3
What's what?	4/5
Description	4
Use of the Ventilog with Anaesthetic Machines	6
Preparation for Use	6
Functional Checks	7
Operation	7
Care and Maintenance	8
Inspection, Storage	9
Trouble Shooting	9
Order List	10

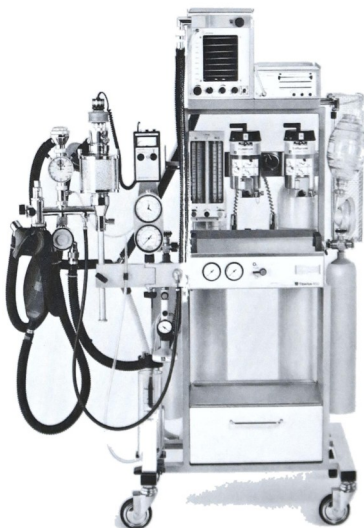

Fig. 1 Ventilog 84 05 200 with latches - fixed on to the base plate of a Dräger Tiberius 800 anaesthetic machine

Front cover: Ventilog 84 04 500 integrated with a Dräger Romulus 800 MV anaesthetic machine

Applications

The Ventilog is an anaesthetic ventilator for adults and for children above 5 kg body weight. In conjunction with a circle system (eg. Draeger circle system 7a) and a source of fresh gas (consisting of, for example, an anaesthetic vaporiser and flowmeters for oxygen and nitrous oxide) the Ventilog forms a complete semi-closed anaesthetic ventilation system.

Warning

● The Ventilog can be used in conjunction with electrically driven apparatus, eg. the Draeger Oxycom oxygen mea-

surement device or the Draeger Capnolug for determination of CO₂, provided the relevant safety regulations are observed. These lay down the conditions under which electrically driven apparatus can be used in conjunction with other apparatus containing gases which support combustion (O₂ and N₂O) and/or form explosive gas mixtures (VDE 0750 § 33 and § 34, IEC 601/1).

● When the Ventilog is driven by oxygen the room must be adequately ventilated.

Electrically-driven apparatus must not be placed **under** the Ventilog.

● The Ventilog can also be used together with inflammable anaesthetics such as ether and cyclopropane, since it is driven pneumatically and requires no electrical power. It is then essential that electrically conductive gas tubing is used, that the anaesthetic machine is connected to a potential equaliser and that only approved electrically-driven apparatuses, eg. Draeger Oxycom, are permitted in the explosion hazard area.

Technical Data

Operating principle	Bellows-in-bottle ventilator with primary/secondary system
Control principle	Solely pneumatic, time-cycled, volume constant
Ventilation frequency ¹⁾	6–40/min, infinitely adjustable
I:E ratio	1:2, non-adjustable
Tidal volumes	50–150 ml with bellows K for children 150–1600 ml with bellows E for adults
Internal compliance	2.6 ml/mbar with bellows K for children 3.4 ml/mbar with bellows E for adults
Minute volume	up to 28 l/min
Working flow	20–80 l/min, infinitely adjustable
Max. working pressure	80 mbar, non-adjustable
PEEP	0–15 mbar, infinitely adjustable
"1"/"0" switch	Main switch for the Ventilog
Drive gas	Oxygen or oil-free compressed air at 2–6 bar pressure from a central supply unit or from compressed gas cylinders
Drive gas consumption	One-third of the working flow setting
Patient system	Autoclavable bellows, removable after releasing the slide-in unit
Anaesthetic gas disposal	Excess exhaled gas is routed to an anaesthetic gas extraction system via an exhaust socket at the rear of the apparatus
Dimensions	Width × height × depth = 212 × 260 × 300 mm
Weight	12 kg

¹⁾ Caution

The frequency control is calibrated using oxygen. If compressed air is used to drive the ventilator the frequency may increase by a maximum of 10%.

What's that? (Figs 2-7)

Fig. 2:

- 1 Slide-in unit
- 2 Connection (for pressure regulation lead 16)
- 3 Control knob for adjusting volume
- 4 Control knob for adjusting ventilation frequency
- 5 Control knob for adjusting PEEP
- 6 Control knob for adjusting inspiratory working flow
- 7 Selector switch for the following modes of operation:
"1" = automatic/controlled ventilation
"0" = manual ventilation via a breathing bag or spontaneous ventilation, with the Ventilog switched off
- 8 Knob for releasing the slide-in unit
- 9 Patient system
- 10 Threaded nozzle for connecting hose to circle system

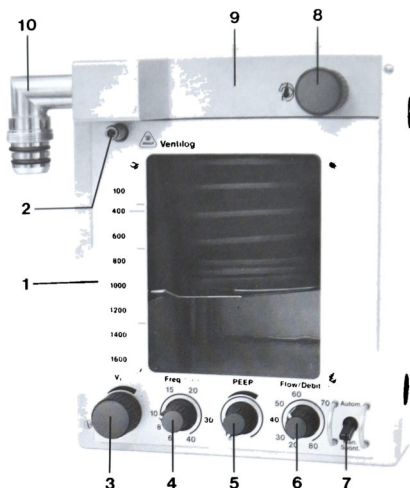

Figs. 3 and 4:

- 11.1 Bellows E for the patient system for adult ventilation
- 11.2 Bellows K for the patient system for children's ventilation (Fig. 4)
- 12 Ventilog housing

Fig. 2 Ventilog front view

Fig. 5:

- 13 Compressed gas connection for oil-free compressed air or oxygen at 2 to 6 bar
- 14 Exhaust gas nozzle with integral non-return valve for transferring anaesthetic gases to a filter or excess anaesthetic gas scavenging system

Fig. 6:

- 15 Pneumatic switching valve
- 16 Control pressure lead
- 17 Connector
- 18 Tubing retainers

Fig. 7:

- 19 Manual switching valve

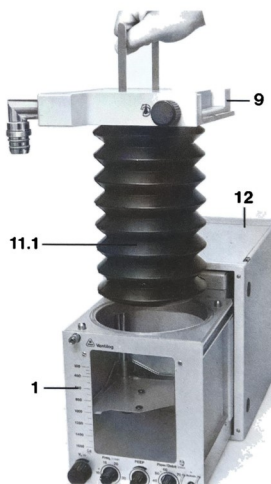

Fig. 3 Ventilog with bellows E (for adults)

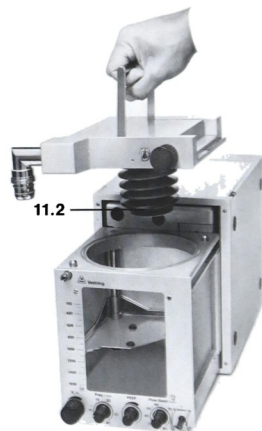

Fig. 4 Ventilog with bellows K (for children)

Description

The Ventilog consists of 4 basic elements:

- 1) A slide-in unit 1 (Fig. 3)
- 2) A patient system 9 (Fig. 3)
- 3) Ventilog housing 12 (Fig. 3)
- 4) A pneumatic switching valve 15 (Fig. 6) or
A manual switching valve 19 (Fig. 7)

Slide-in unit

The slide-in unit 1 contains the pneumatic control-elements, with control-knobs, and the pressure chamber with the drive for the primary system. Clockwise rotation of the control-knobs increases the value of the parameter controlled.

The stroke (tidal) volume V_T is adjusted by

the control knob 3. The set value is shown by an indicator to the right of the ml scale. One turn corresponds to a volume change of approx. 50 ml. By principle a difference may occur between the set and measured tidal volumes when fresh gas is flowing continuously from the anaesthetic machine to the circle

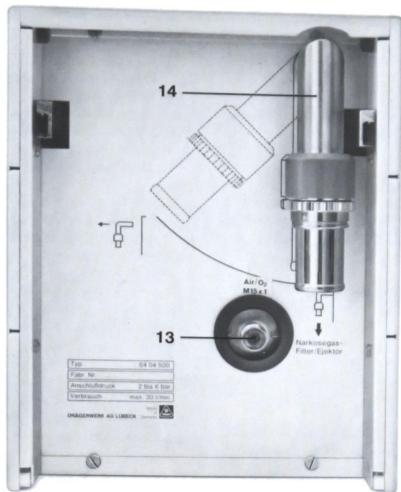

Fig. 5 Ventilator rear view

system. The difference becomes greater the higher the fresh gas flow and the lower the selected ventilation frequency are and results from the addition of fresh anaesthetic gas to the gas delivered from the Ventilator during inspiration.

For example;

Fresh anaesthetic gas flow	3 l/min
Ventilation frequency	15/min

The Ventilator has a fixed inspiratory:expiratory time ratio of 1:2, i.e. $\frac{1}{3}$ of the fresh anaesthetic gas will flow to the patient during the inspiratory phase, equivalent to 1 l/min. At a ventilation frequency of 15/min the patient receives $\frac{1}{3} \times 67 \text{ ml} = 22 \text{ ml}$ of this per inspiratory stroke additionally to the stroke volume contained in the bellows. At a ventilation frequency of 10/min this would amount to 100 ml additionally per inspiratory stroke.

In order to keep the difference between the set and measured tidal volume as small as possible in practice, the Ventilator V_T scale is calibrated with a fresh gas flow of 4 l/min at a ventilation frequency of 12/min.

Caution!

The scale readings from 100 to 1600 ml for V_T only apply when the bellows E for adults is in use. When the small bellows K for children is in use the volume can only be adjusted between 0 and 500 ml. One turn of the control knob will, therefore, correspond to a volume change of approx. 12 ml. The exact value of the patient's expiratory tidal volume can be determined by volume measurements, e.g. with a Draeger volumeter or Draeger Spirolog 1N.

Patient system

When ready for use, the slide-in unit 1 and the patient system 9 form one unit in the Ventilator housing. The contact surface between the patient system and the slide-in unit is sealed by a large sealing ring (see Fig. 8).

Changing the patient system

Both the patient system 9 and the exhaust gas nozzle 14 are in contact with the patient's exhaled gases. The following procedure should be used to remove these parts from the ventilator:

Pull the locking knob 8 forward, engage it and then turn it through 90° anticlockwise. Slide the patient system and slide-in unit out of the housing. Lift the patient system out by the handle. Turn the exhaust gas nozzle 14 (Fig. 5) clockwise to the marked position and then pull it out.

To re-assemble the system the above procedure is reversed. Hang the patient system in the slide-in unit by locating the two adjustable bolts on the top of the slide-in unit with the corresponding holes on the bottom of the patient system, then push the slide-in unit and patient system back into the housing against spring pressure which must be overcome before a definite locking is felt.

Replace the exhaust gas nozzle 14 (Fig. 5) in the marked position and secure it by turning it anticlockwise. Connection between the patient system and the bellows should be handled very carefully, push the bellows (11.1., 11.2) and its connecting sleeve fully on to the central connecting

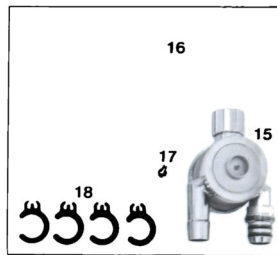

Fig. 6 Pneumatic switching valve



Fig. 7 Manual switching valve

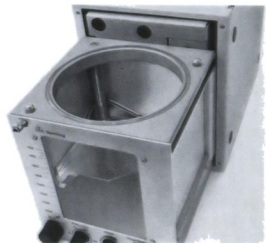

Fig. 8 Sealing ring between the slide-in unit and the patient's system

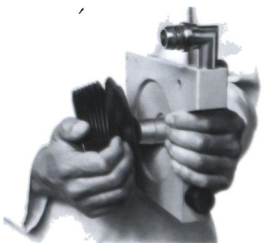

Fig. 9 Replacement of the bellows on the patient's system

nozzle of the patient system with repetitive twisting and turning motions (see Fig. 9).

Caution!

- Only authentic Draeger Ventilator bellows must be used. An identification

mark is stamped on the under side of the bellows.

- The sealing ring (Fig. 8) must be protected from damage and the mating surfaces of the patient system 9 in contact with the sealing ring must be kept clean.
- When the patient system 9 has been lifted out of the slide-in unit 1 the slide-in unit itself **cannot be secured** in the Ventillog, and hence if the anaesthetic machine is moved suddenly, the unit could slide forward unexpectedly.
- The Ventillog must be securely attached to the anaesthetic machine with which it is being used.

Ventilog housing

The Ventillog housing 12 is a standard Draeger system housing. Draeger monitoring devices such as the Spirolog 1N, the Capnlog or the Barolog can be attached easily **on top** of the Ventillog housing.

Warning!

Safety regulations IEC 601/1, VDE 0750 require that oxygen driven apparatus such as the Ventillog must be mounted **underneath** electrically operated equipment. This is advisable to minimize the risk of accumulation of oxygen in the electrical equipment. Oxygen is heavier than air and is therefore not likely to accumulate and increase the fire risk as long as the electrical equipment is mounted above the oxygen source. See also the warning in the "Applications" section on page 3.

Switching valve for automatic and manual ventilation

The use of the pneumatic or manual switching valve allows the ventilation to be carried out automatically with the Ventillog or manually with a breathing bag. Attach the switching valve to the circle system by the threaded connection for the breathing bag.

Pneumatic switching valve (Fig. 6)

With the Ventillog selector switch 7 in position "1", the pneumatic switching valve 15 is in the automatic ventilation mode and a control pressure of 1.4 bar is supplied to the switching valve via the control-pressure lead 16 and connects the Ventillog to the circle system.

With the Ventillog selector switch 7 in position "0" the switching valve is in the manual ventilation mode, the control-pressure lead is not under pressure and the Ventillog is switched off and connects the breathing bag to the circle system for manual or spontaneous ventilation.

Attachment of the pressure regulation lead

Push the control-pressure lead 16 on to the nozzle of the switching valve (Fig. 10) and insert the connection 17 on the other end of the control-pressure lead into the coupling 2 on the Ventillog (Fig. 11). This connection can be disengaged by sliding back the knurled ring on the connector.

Caution!

The control-pressure lead must always be loosely coiled and free of kinks. It should be secured to the connecting hose from the Ventillog with the tubing retainers 18 provided.

Manual switching valve (Fig. 7)

The manual switching valve has two positions:

Upper position:

"Autom." – the valve connects the Ventillog to the circle system for automatic ventilation.

Lower position:

"Man./Spont." – the valve connects the breathing bag to the circle system for manual or spontaneous ventilation.

Warning!

It is advisable that when operating the manual switching valve the Ventillog selector switch 7 should also be operated as follows:

Manual switching valve 19	Ventilog switch 7
"Autom."	"1"
"Man./Spont."	"0"

Attachment of the Ventillog to Anaesthetic Machines

The Ventillog can be attached to all Draeger anaesthetic machines of the 800 series. The various modes of attachment are described in the Operating Manuals for these anaesthetic machines.

The Ventillog may be attached instead of a Pulmomat 19 to anaesthetic machines such as the Romulus 19, Tiberius 19, Sulla 19, Trajan, or to a wall-rail anaesthetic machine. The attachment is made by a base plate and hinged arm. Figures 12 and 13 show the attachment of the Ventillog to a Tiberius 19 to illustrate the method and the Ventillog is connected to other anaesthetic machines in a similar manner. The hinged arm allows the Ventillog to be placed in a position which is convenient for the anaesthetist.

The order list gives details of the accessories necessary to attach the Ventillog to these anaesthetic machines.

Preparation for Use

Clean and disinfect the Ventillog before connecting it to an anaesthetic machine. Hang the patient system 9 in the slide-in unit 1 and secure the unit in the machine. Inset the exhaust gas nozzle 14 into the rear of the Ventillog. Attach the connecting hose from the patient system to the nozzle of the switching valve which is mounted on the circle system carrier, and tighten the threaded connector to secure it.

Connect the Ventillog to a compressed gas (oxygen or compressed air) supply (connection 13 at the rear of the apparatus), and connect the exhaust gas nozzle 14 to an excess anaesthetic gas scavenging system or an anaesthetic filter according to Fig. 13.

Check that the supplies of compressed gas and anaesthetic agent are adequate.



Fig. 10 Attaching the control-pressure lead 16 to the pneumatic switching valve

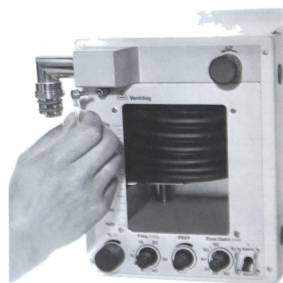

Fig. 11 Connecting and disconnecting the control-pressure lead to the Ventillog

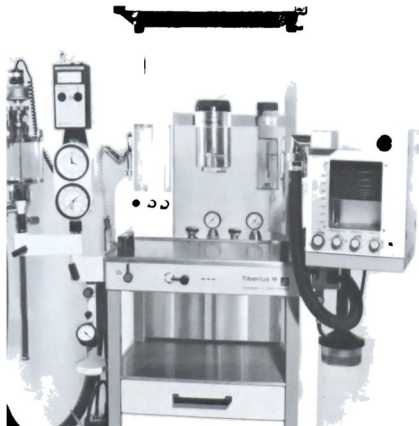

Fig. 12 Draeger Tiberius 19 anaesthetic machine with Ventilog



Fig. 13 Rear view of Ventilog attached to Tiberius 19 showing the anaesthetic filler attached to the exhaust gas nozzle

Carry out a functional check of the circle system in accordance with the Operating Manuals for the anaesthetic machine and the circle system.

Functional Checks

Set all control knobs and switches at the green index mark positions. Attach the bellows E for adults to the patient system 9. Set the Ventilog tidal volume at 500 ml.

Tests for gas leaks

- To test the whole system comprising Ventilog, switching valve and circle system 7a.
Shut off the fresh gas flow.
Open the patient's Y-piece during inspiration and close it again when expiration commences. The bellows will now be fully compressed and completely emptied and, if the system is airtight, should remain so. If not, see "Trouble Shooting" on page 9.
- To test the switching valve 15 and non-return valve in the exhaust gas nozzle 14.
Shut off the fresh gas flow.
Leave the Y-piece open during the test. The bellows will be fully emptied at the end of inspiration.
Before the apparatus switches to expiration, switch off the Ventilog respectively if the manual switching valve is in use select the "Man/Spont." switch position. The bellows will remain fully emptied if the switching valve and the non-return valve are airtight. If this is not the case see "Trouble Shooting" on page 9.
- To test the manual ventilation system
Set the fresh gas flow at 4 l/min.

Set the Ventilog switch at "0" and close off the Y-piece tightly.

Switch on the excess pressure relief (APL-) valve on the circle system (the lever of the switch should be in the vertical position pointing upwards) and set the excess pressure valve at 30 mbar.

When the breathing bag is squeezed the manometer on the circle system must show an immediate increase in pressure.

Function test

Close the excess pressure valve on the circle system (switch lever in the horizontal position). Connect the patient Y-piece to the demonstration thorax. Set the fresh gas flow on the anaesthetic machine at about 4 l/min. The Ventilog must go through a ventilatory cycle with a frequency of about 12/min and an I:E ratio of about 1:2.

The Ventilog bellows rises during **Inspiration** and the pressure must rise in the circle system whilst the volumeter must remain stationary. During **expiration** the bellows will touch the stop plate and the pressure in the circle system falls back to zero. The tidal volume exhaled should be measured by a volume measuring instrument, eg. Draeger Spirolog 1N or a Volumeter. The up-and-down movements of the bellows should be straight and level and there should be no oscillation of the bellows edge which would indicate that the bellows has not been mounted evenly on the nozzle of the patient system. Set the PEEP adjustment control knob 5 at its maximum value against the right hand end-stop. The end expiratory pressure shown on the airway pressure manometer in the circle system must be at least 15 mbar

Operation

Adjust the airway pressure manometer in the circle system to read zero. Connect the patient to the Y-piece.

Set the ventilation parameters according to clinical requirements.

Automatic ventilation

Set the switch 7 in position "1". If the manual switching valve is in use select the "Autom." switch setting. Set the excess pressure relief valve in the circle system in the "closed" position (lever horizontal) or in the "pressure limited" position (lever vertical and pointing upwards). The full pressure reserve of the Ventilog is available for automatic ventilation only if the excess pressure valve of the circle system is closed. (See "Hints for efficient ventilation" on page 8.)

Manual ventilation

Set the switch 7 in position "0". If the manual switching valve is in use select the "Man/Spont." switch setting. Switch on the excess pressure relief valve on the circle system and adjust it to give the desired maximum inspiratory pressure value.

Spontaneous ventilation

Set the switch 7 in position "0". If the manual switching valve is in use select the "Man/Spont." switch setting. Set the excess pressure relief valve on the circle system to the "spontaneous" position.

After use

When automatic ventilation is discontinued place the switch 7 in the "0" position.

Hints for efficient ventilation

Bellows is not completely emptied at the end of the inspiratory phase

- 1 Select a higher flow rate-check airway pressure
- 2 Select a lower ventilation frequency in order to prolong the inspiration time

Bellows does not reach the lower stop at the end of expiration

- 1 Check that the excess pressure relief valve on the circle system is closed or set it at a high enough value
- 2 Check the setting of the fresh anaesthetic gas flow

Airway pressure manometer shows a negative reading while the bellows is filling in the expiratory phase

The negative pressure is created by the intrinsic resistance of the volumeter in combination with the suction effect of the bellows during the filling process. This can be avoided by placing the airway manometer before the volumeter in the circuit. The negative pressure being indicated is not developed in the patient's lung.

Measured tidal volume too small

- 1 Excess pressure relief valve on circle system not closed or set at too low a pressure.
- 2 Working flow set too low so that the bellows does not empty fully

Caution!

When a patient is disconnected, any volume measurement device placed in the expiratory limb of the circle system will still show a reading since, the bellows of the ventilator will then draw in atmospheric air via the volume measurement device. The airway pressure will, however, fall, and this will be indicated visually on the pressure manometer in the circle system and audibly if pressure monitoring equipment fitted with a disconnection alarm, eg. Draeger Precorm or Barolog is in use.

When adjusting the PEEP value it should be noted that the ventilator should make 5 respiratory cycles before the exact value is read.

Care and Maintenance

whole apparatus may be upset. When the patient system has been removed the slide-in unit cannot be secured in the Ventilog.

The parts of the Ventilog in contact with the exhaled breath of the patient (patient system 9 exhaust gas nozzle 14, the connecting hose from the switching valve to the Ventilog or from the switching valve to the breathing bag for manual ventilation) may be sterilised by autoclaving at max. 120°C.

The patient system of the Ventilog is interchangeable so that after anaesthetic ventilation is concluded a clean and disinfected replacement patient system can be immediately hung in the slide-in unit of the Ventilog and connected ready for the next patient.

Dismantling

Remove the connecting hose from the Ventilog to the switching valve, the control-pressure tubing (applicable), the exhaust gas nozzle and the switching valve. Pull the slide-in unit forward¹⁾ and lift out the patient system.

Pull off the bellows from the nozzle.

The switching valve should not be dismantled for cleaning and maintenance.

¹⁾ Warning
When the slide-in unit is pulled forward, the balance of the

Disinfection in the Dräger Aseptor[®]

The Ventilog can be disinfected in the Aseptor.

The apparatus should have been cleaned as described. All parts must be dry otherwise they may smell unpleasant after disinfection.

The Ventilog should be re-assembled before being treated in the Aseptor. Push the bellows and the connecting hose on to the respective nozzles on the patient system. Hang the patient system in the slide-in unit and secure it in the Ventilog housing. Push the connecting hose on to the corresponding nozzle of the switching valve. Plug in the exhaust gas nozzle. Connect the Ventilog to a compressed gas supply or to the Aseptor. Set all parameters at the "green point" symbol, and the volumeter V₇ at maximum value. Connect the hose from the switching valve to the circle system. Leave the patient connection on the Y-piece. The Ventilog will now operate in the automatic mode and suck in disinfectant gas from the interior of the Aseptor via the open Y-piece.

Disinfection of dismantled patient system and connecting hose in the Aseptor

Push the connecting hose on to the connecting nozzle of the patient system and push the free end on to a suction nozzle of the Aseptor. Put the bellows and the exhaust gas nozzle on the Aseptor tray. Turn the manual switching valve to the "Man./Spont." position and connect it to a suction nozzle of the Aseptor via the connection for manual ventilation.

Fill the Aseptor with disinfectant and neutralising agents and set it in operation in accordance with the Operating Manual.

Re-assembly of the apparatus

- Push the bellows on to the central connector nozzle of the patient system (Fig. 11), by taking the compressed bellows in one hand and the patient system in the other hand and pushing the bellows sleeve on to the nozzle with a turning motion until the stop is reached.
- Hang the patient system in the slide-in unit and then slide the unit into the Ventilog until it locks into place.
- Push the connecting hose on the Ventilog and switching valve and secure it with the screw connectors.
- Attach the switching valve to the circle system carrier.
- Push the breathing bag on to the switching valve.
- Insert the exhaust gas nozzle into the rear of the Ventilog.

Warning!

A functional check must be carried out after maintenance, disinfection or steam sterilisation (see the section on "Functional checks", page 7)

Trouble Shooting

Any leakages which may be detected in the tests after reassembly (see the section "Functional checks" page 7) can usually be remedied as follows:

- Tighten all screws and push-in connections.
- Check the tightness and correct alignment of the hoses and the bellows. The bellows must be pushed on to the nozzle right up to the stop.
- Examine the sealing ring between the slide-in unit and the patient system.
- Check that slide-in unit is securely fixed in place.
- Ensure that the exhaust gas nozzle is securely inserted in the rear of the apparatus.

The following table sets out a system for finding and correcting faults:

Inspection

The Ventilog should be inspected twice yearly by the Technical Service Department of Drägerwerk AG.

Storage

The Ventilog must be stored under dust-free, dry conditions.

Fault and test procedure	Cause and Remedy
<p>1</p> <p>If, When testing for gas leaks (see "Functional check" on page 7, checks 1 and 2), the bellows expand, proceed as follows: Repeat the test but instead of plugging the Y-piece, seal the threaded nozzle 10 of the Ventilog</p> <p>1.1 Bellows do not expand further</p> <p>1.2 Bellows continue to expand Plug exhaust gas nozzle 14</p> <p>1.2.1 Bellows do not continue to expand</p> <p>1.2.2 Bellows continue to expand</p>	<p>Search for leaks in the circle system: check the tightness of all screwed connections and push-on connections in the circle system.</p> <p>Search for leaks in the Ventilog.</p> <p>Defective non-return valve in exhaust gas nozzle 14. Contact the Dräger Technical Customer Service.</p> <p>Examine bellows for cracks and replace if necessary.</p>
<p>2</p> <p>Check the switching valve 15</p> <p>2.1 Set selector switch 7 at "1". With the Y piece closed, the breathing bag must not inflate and deflate.</p> <p>2.2 Set selector switch 7 at "0". During manual ventilation with the Y-piece closed. Open the hose connection to the Ventilog no gas should issue from the connector on the switching valve.</p>	<p>If gas issues during test procedures 2.1 or 2.2 the switching valve should be dismantled and examined for leaks.</p>
<p>3</p> <p>Automatic ventilation not possible with selector switch 7 in position "1"</p>	<p>Control-pressure lead 16 is kinked. Straighten out lead. Preferably renew it.</p>
<p>4</p> <p>Manual ventilation not possible with selector switch 7 in position "0"</p>	<p>4.1 Pressure regulation lead 16 is kinked. Straighten out lead.</p> <p>4.2 Selector switch 7 is not releasing the pressure in the pressure regulation lead fully: Contact the Customer Technical Service If this fault occurs during ventilation the control-pressure lead should be removed immediately from the switching valve so that manual ventilation can be continued</p>
<p>5</p> <p>Bellows do not move</p>	<p>The apparatus must be examined by the Customer Technical Service of Drägerwerk AG</p>

Order List

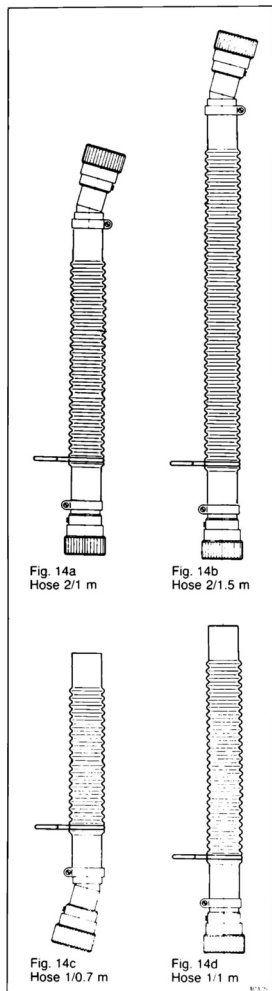

Fig. 14a
Hose 2/1 m

Fig. 14b
Hose 2/1.5 m

Fig. 14c
Hose 1/0.7 m

Fig. 14d
Hose 1/1 m

Designation and description	Order No.
<p>Basic versions</p> <p>For building in to the following Dräger anaesthetic apparatus. Romulus 800 V, Romulus 800 MV, Tiberius 800, Sulla 800 V</p> <p>Ventilog Automatic anaesthetic ventilator for adults and children, time cycled and volume-constant.</p> <p>For attachment (with built-in latches) to Dräger anaesthetic machines Romulus 800, Romulus 800 M, Tiberius 800, Sulla 800, Tiberius 19, Sulla 19, Trajan, Trajan 800 and wall-rail anaesthetic machine</p> <p>Ventilog as above, but with additional latches.</p>	<p>84 04 500</p> <p>84 95 200</p>
<p>Accessories required for operation</p> <p>a) For Romulus 800 V and 800 MV as well as Sulla 800 V</p> <p>Connecting hose 2/1 m (Fig. 14a) Pneumatic switching valve¹⁾ including control-pressure tubing alternatively: Manual switching valve¹⁾</p> <p>For driving the Ventilog from the anaesthetic machine Connecting hose 0.6 m alternatively (for driving from a central supply installation) O₂-compressed air connecting hose 3 m or O₂-compressed air connecting hose 5 m</p>	<p>84 04 758</p> <p>84 04 950</p> <p>84 05 305</p> <p>M 25050</p> <p>M 22494</p> <p>M 22495</p>
<p>b) For Romulus 800, Romulus 800M as well as Sulla 800 (with Ventilog latched-on to the base plate)</p> <p>Connecting hose 2/1.5 m (Fig. 14b) Pneumatic switching valve¹⁾ including control-pressure tubing alternatively: Manual switching valve¹⁾</p> <p>For driving the Ventilog from the anaesthetic machine Connecting hose 1.2 m alternatively (for driving from a central supply installation) O₂-compressed air connecting hose 3 m or O₂-compressed air connecting hose 5 m</p>	<p>84 04 732</p> <p>84 04 950</p> <p>84 05 305</p> <p>M 25518</p> <p>M 22494</p> <p>M 22495</p>
<p>c) For Tiberius 800:</p> <p>Holder (for Ventilog 84 04 500 only) for mounting the Ventilog on the left-hand side of the Tiberius 800 Connecting hose 2/1.5 m (Fig. 14b) Pneumatic switching valve¹⁾ including control-pressure tubing alternatively: Manual switching valve¹⁾</p> <p>For driving the Ventilog from the anaesthetic machine Connecting hose 1.2 m alternatively (for driving from a central supply installation) O₂-compressed air connecting hose 3 m or O₂-compressed air connecting hose 5 m</p>	<p>M 25320</p> <p>84 04 732</p> <p>84 04 950</p> <p>84 05 305</p> <p>M 25518</p> <p>M 22494</p> <p>M 22495</p>
<p>d) For Romulus 19 and Tiberius 19:</p> <p>Connecting hose 1/0.7 m (Fig. 14c) Connecting hose 1/1 m (Fig. 14d) Hinged arm Base plate 0.5 B Pneumatic switching valve¹⁾ including control-pressure tubing alternatively: Manual switching valve¹⁾</p>	<p>84 04 733</p> <p>84 04 731</p> <p>M 23005</p> <p>84 04 720</p> <p>84 04 950</p> <p>84 05 305</p>

¹⁾ see the notice at the end of the order list

Designation and description	Order No.
<p>For driving from the anaesthetic machine:</p> <p>Connecting hose 1 m</p> <p>Connecting valve</p> <p>alternatively (for driving from a central supply installation)</p> <p>O₂-compressed air connection hose 3 m</p> <p>or</p> <p>O₂-compressed air connecting hose 5 m</p>	<p>M 17670</p> <p>M 20019</p> <p>M 22494</p> <p>M 22495</p>
<p>e) For Sulla 19:</p> <p>Connecting hose 2/1.5 m (Fig. 14b)</p> <p>Hinged arm</p> <p>Base plate 0.5 B</p> <p>Pneumatic switching valve¹⁾ including control-pressure tubing</p> <p>alternatively:</p> <p>Manual switching valve¹⁾</p> <p>For driving from the anaesthetic machine:</p> <p>Connecting hose 1 m</p> <p>Connecting valve</p> <p>alternatively (for driving from a central supply installation)</p> <p>O₂-compressed air connecting hose 3 m</p> <p>or</p> <p>O₂-compressed air connecting hose 5 m</p>	<p>84 04 732</p> <p>M 23005</p> <p>84 04 720</p> <p>84 04 950</p> <p>84 05 305</p> <p>M 17670</p> <p>M 20019</p> <p>M 22494</p> <p>M 22495</p>
<p>f) For Trajan and Trajan 800:</p> <p>Connecting hose 2/1.5 m (Fig. 14b)</p> <p>Hinged arm</p> <p>Base Plate 0.5 B</p> <p>Pneumatic switching valve¹⁾ including control-pressure tubing</p> <p>alternatively:</p> <p>Manual switching valve¹⁾</p> <p>For driving the Ventilog from a central supply installation:</p> <p>O₂-compressed air connecting hose 1.5 m</p>	<p>84 04 732</p> <p>M 23005</p> <p>84 04 720</p> <p>84 04 950</p> <p>84 05 305</p> <p>M 23343</p>
<p>g) For wall-rail anaesthetic apparatus:</p> <p>Connecting hose 2/1.5 m (Fig. 14b)</p> <p>Hinged arm</p> <p>Base plate 0.5 B</p> <p>Wall bracket for permanent mounting on the wall</p> <p>Pneumatic switching valve¹⁾ including control-pressure tubing</p> <p>alternatively:</p> <p>Manual switching valve¹⁾</p> <p>For driving the Ventilog from a central supply installation</p> <p>O₂-compressed air connecting tubing 1.5 m</p>	<p>84 04 732</p> <p>M 23005</p> <p>84 04 720</p> <p>M 24349</p> <p>84 04 950</p> <p>84 05 305</p> <p>M 23343</p>
<p>Accessories recommended for monitoring</p> <p>For continuous measurements and monitoring of the airway pressure in the circle system:</p> <p>1. Barolog</p> <p>with visual and acoustic alarm in the event of disconnection or obstruction</p> <p>Accessory required:</p> <p>Measurement connection</p> <p>alternatively:</p> <p>2. Airway pressure manometer "Precom"</p> <p>gives an acoustic alarm if a set pressure value is not reached within 15 sec.</p>	<p>83 02 400</p> <p>M 25638</p> <p>E 9711</p>
<p>Special accessories</p> <p>Instrument tray 0.5 B</p> <p>for latching-on to the Ventilog</p> <p>Demonstration thorax</p>	<p>2 M 17680</p> <p>M 20558</p>

¹⁾ see notice at the end of the order list

Designation and description	Order No.
Replacement parts for sterilisation	
Patient set (patient system including the anaesthetic gas nozzle)	84 05 040
Pneumatic switching valve ¹⁾	84 04 950
Manual switching valve ¹⁾	84 05 305
Hose 2/1 m (Fig. 14a)	84 04 758
Hose 2/1.5 m (Fig. 14b)	84 04 732
Hose 1/0.7 m (Fig. 14c)	84 04 733
Hose 1/1 m (Fig. 14d)	84 04 731
Spare and expendable parts	
Hose retainers, set of 10 (see Fig. 6)	84 04 047
Hose 2 x 1.5 (see Fig. 6) delivery in m	12 03 622
Bellows E (for adults)	2 M 8138
Bellows K (for children)	84 00 179
Anaesthetic exhaust-gas nozzle	84 04 690
¹⁾ Notice The pneumatic and manual switching valves are also available with connections conforming to ISO standard ISO/DB 5358	
Pneumatic switching valve ISO including regulatory tubing	84 05 276
Manual switching valve ISO	84 05 295

Subject to modifications!



DRÄGERWERK AG LÜBECK
FEDERAL REPUBLIC OF GERMANY

Postfach 1339, Moislinger Allee 53/55
D-2400 Lübeck 1
(451) 882-0, 2 6807-0