

ORTHOPHOS XG 5 / Ceph ORTHOPHOS XG 3

Inspection and maintenance
and safety-related checks

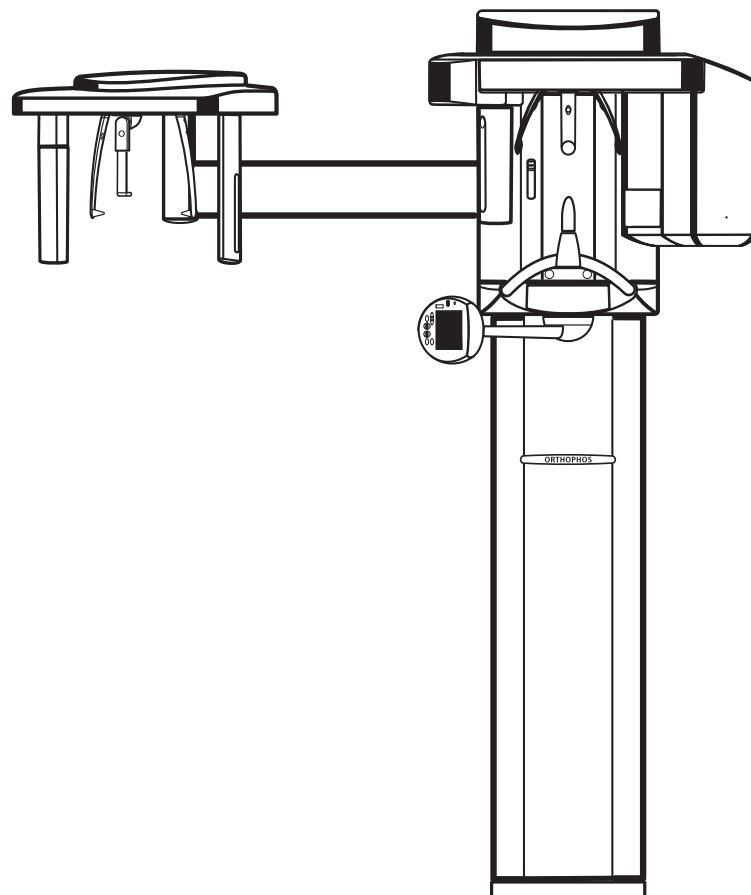

Dear customer

You would like to have and will have many years of satisfaction with your **Sirona** X-ray unit.

Safety and reliability are necessary to ensure this.

Your dental dealership offers you service by specially trained engineers for this purpose.

The maintenance should ensure that your product is permanently safe and operational. All components subject to normal wear and tear are checked and, if necessary, replaced. Maintenance work may be performed by the operator only if this is described on the part of Sirona Dental Systems GmbH, otherwise only authorized service engineers of Sirona Dental Systems GmbH or its authorized dealers may be entrusted with the work.

In case you have not concluded a maintenance contract, please contact the customer service department of your dental dealership.

The performed maintenance must be documented in this document, which must be kept with the unit.

We wish you much success and pleasure with your quality product
from **SIRONA Dental Systems**.

List of Contents

1	General information.....	5
1.1	Inspection and maintenance and safety-related checks	5
1.2	Customer data	5
2	Annual inspection performed by the system owner or other authorized persons.....	6
2.1	Technical documents	6
2.2	System accessories	7
2.3	Surfaces of the unit	8
2.4	X-ray unit	9
2.5	System safety	9
2.6	Exposure safety	10
2.7	Key functionality	11
2.8	Light localizer functionality	11
2.9	Sensor functionality	12
2.10	Image quality	12
2.11	Height adjustment functionality	13
2.12	Documenting your yearly inspection	14
3	Safety-related checks by the service engineer in compliance with standard IEC 62353.....	15
3.1	General information for the service engineer	15
3.2	Intervals for safety-related checks	16
3.3	Safety-related check	16
3.4	Documenting the safety-related check	17
4	Maintenance by the service engineer	18
4.1	General information for the service engineer	18
4.2	Maintenance interval	19
4.3	Checking the records	19
4.4	Labels on the system	20
4.5	Serial numbers of the system	21
4.6	Functional test	22
4.7	Assessing X-ray exposures	23
4.8	Checking the tube data	23
4.9	Diaphragm check	24
4.10	Checking the cables for damage	24
4.11	Safety checks	25
4.12	Final work	25
4.13	Documenting maintenance work	26

1 General information

1.1 Inspection and maintenance and safety-related checks

Inspections, preventive maintenance and safety-related checks must be performed **at scheduled intervals** to protect the health and safety of patients, users and other persons.

- In order to ensure the operational safety and functional reliability of your product, you as the **system owner should inspect the equipment at least once a year** or commission your dental depot to do so. The information provided in **Chapter 2 'Annual inspection performed by the system owner or other authorized persons'** should be helpful here. If one or more checks to be performed do not lead to satisfactory results, please contact your dental depot.
- Medical devices are designed in such a way that the first occurrence of a fault does not create a hazard to the safety of the patient, the user or other persons. Hence it is important to detect such faults before a second fault occurs, which might then lead to safety hazards. For that reason it is essential to **perform safety checks** aimed particularly at detecting electrical faults **every 2 years**. The information provided in **Chapter 3 "Safety-related checks performed by the service engineer"** should be helpful here.
- In addition, your **dental depot offers you maintenance** of the system by specially trained engineers; see **Chapter 4 "Maintenance by the service engineer"**.

All inspection and maintenance work and safety-related checks performed by the system owner or service engineer must be recorded in this document and kept near the unit!

1.2 Customer data

Customer	
Last name:	
First name:	
Street:	
Post code / city:	
Phone:	











2 Annual inspection performed by the system owner or other authorized persons

2.1 Technical documents

Technical documents	Answer questions with yes (✓) or no (-)											
Date (please enter month/year)												
Operating Instructions available?												
Installation Requirements available?												
Installation Report / Warranty Passport available and completely filled out?												
Declaration of Conformity by system integrator available?												
X-ray System Logbook available (for Germany only)?												

If no ⇒ Order missing documents from your dealer.

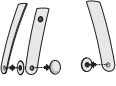
2.2 System accessories

System accessories (see Operating Instructions) Not all accessories listed here may be included in the scope of supply, cross out what does not apply.		Answer questions with yes (✓) or no (-)											
Date (please enter month/year)													
	Needle phantom available?												
	Test phantom available? (worldwide, incl. Germany)												
	Test phantom available? (Germany, as from 07.2015)												
	Test phantom for Ceph units available?												
	Test phantom for ORTHOPHOS XG 3 available?												
	Bite block, yellow/blue available?												
	Contact segment, yellow/blue available?												
	Temporomandibular joint support 1 and 2 available?												
	Ear holders available?												
	Forehead support, temple supports and Contact pads available?												
	Chin rest completely available?												

If no ⇒ Order missing accessories from your dealer.

2.3 Surfaces of the unit

Cover parts	Answer questions with yes (✓) or no (–)											
Date (please enter month/year)												
All cover parts attached at X-ray unit (Fig. 1)?												
All screws on unit housing available?												
Cover parts and mirrors free of damage (no surface damages, e.g. scratches)?												
All cover parts in clean condition? Clean X-ray unit with the recommended cleaning agents (see Operating Instructions).												

If no ⇒ Inform your dealer.

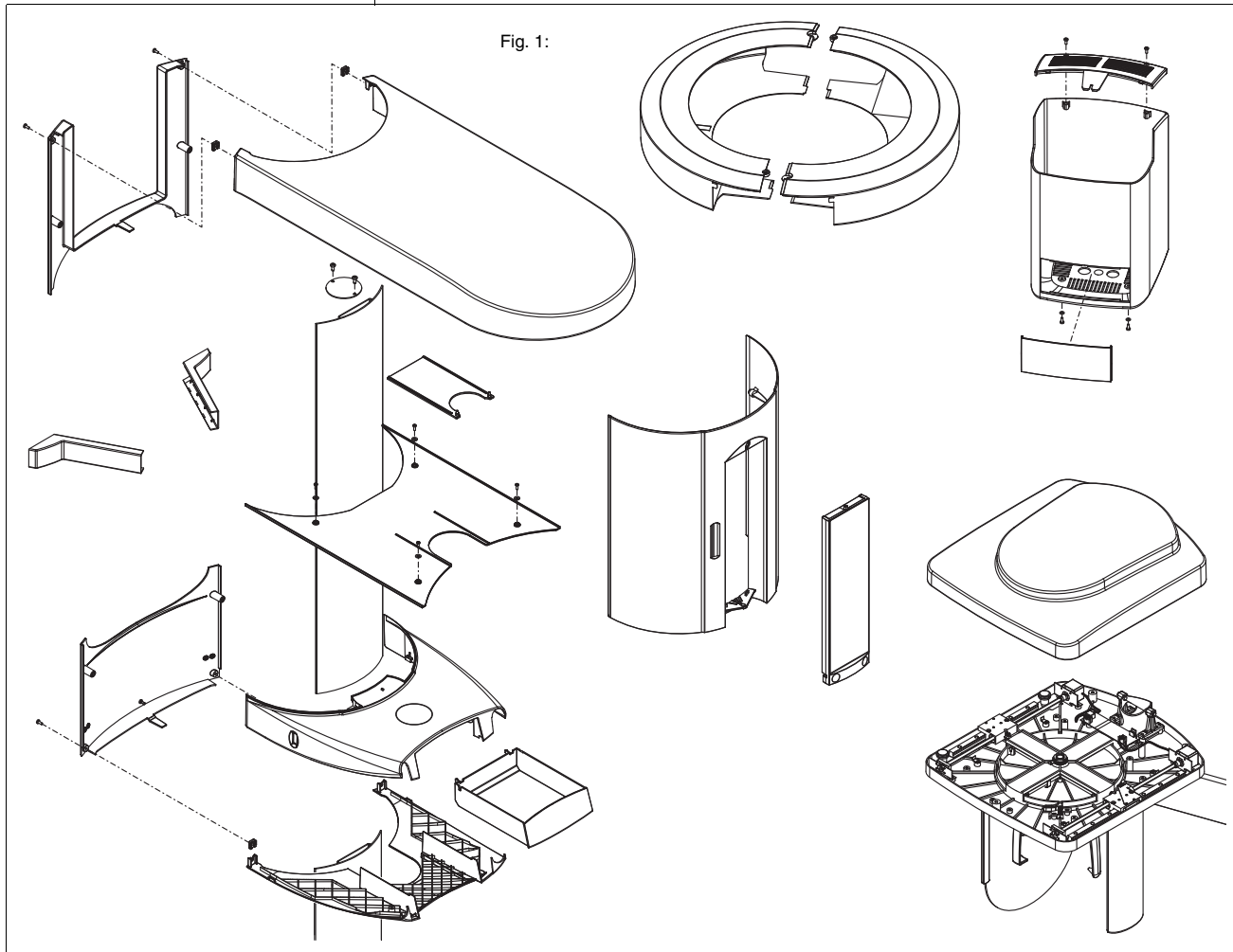

2.6 Exposure safety

Exposure safety	Answer questions with yes (✓) or no (–)												
Date (please enter month/year)													
No repeated occurrence of a certain error message?													
Optical and acoustic signal present when radiation is released?													
Is the release button free of cleaning agent residues and freely movable?													
Exposure is immediately interrupted when radiation button is released prematurely?													
Does rotational movement occur without any atypical running noises?													

If no ⇒ Inform your dealer.

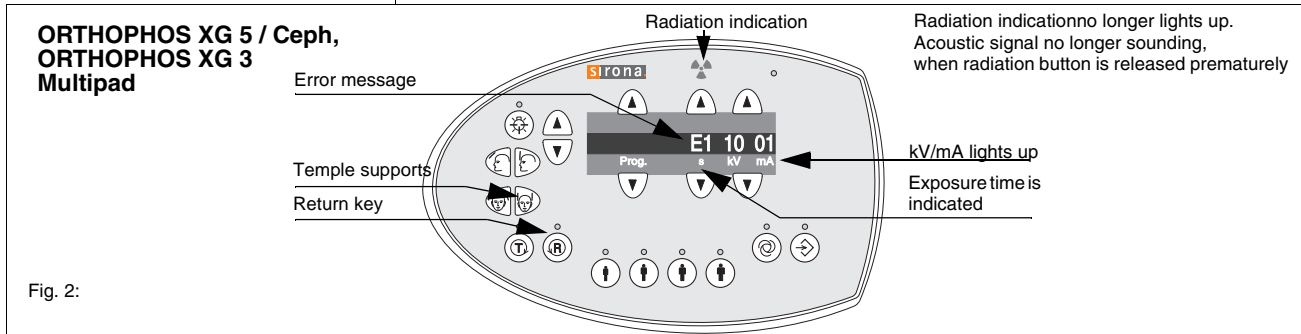

2.7 Key functionality

Key functionality	Answer questions with yes (✓) or no (–)											
Date (please enter month/year)												
Membrane foil of the Multipad keys without cracks or holes?												
All numbers and letters on the Multipad show up completely?												
Can the Multipad be positioned reliably and does it remain in the desired position?												

If no ⇒ Inform your dealer.

**ORTHOPHOS XG 5 / Ceph,
ORTHOPHOS XG 3
Multipad**

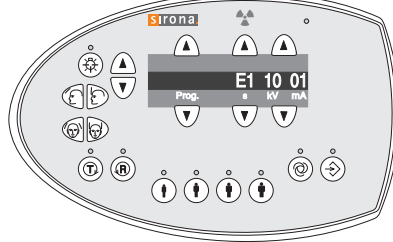

2.8 Light localizer functionality

Light localizer	Answer questions with yes (✓) or no (–)											
Date (please enter month/year)												
Vertical and horizontal light beam visible (Fig. 1)?												
Position of horizontal light beam can be changed and remains as set?												

If no ⇒ Inform your dealer.

Vertical and horizontal light beam

Fig. 1:

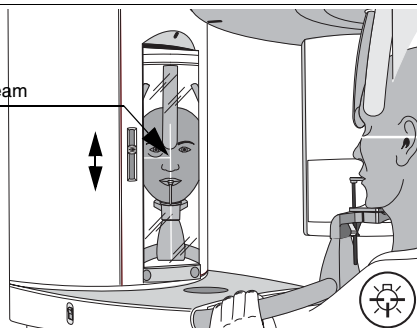

2.9 Sensor functionality

Sensor	Answer questions with yes (✓) or no (–)											
Date (please enter month/year)												
Sensor can be removed and insert up to stop easily (Fig. 1)?												
Sensor fits snugly in the guide?												

If no ⇨ Inform your dealer.

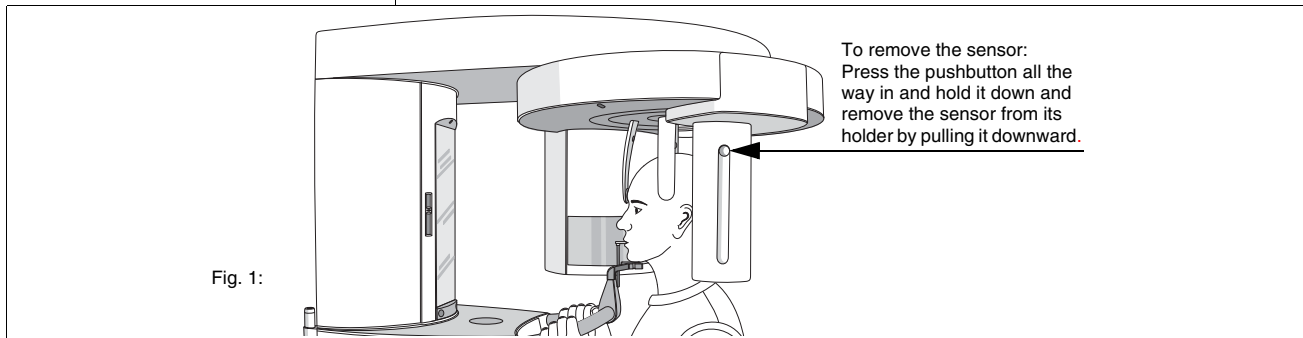

2.10 Image quality

Image quality	Answer questions with yes (✓) or no (–)											
Date (please enter month/year)												
Typical exposure parameters are not adjusted in order to achieve a constant image quality?												

If no ⇨ Inform your dealer.

2.11 Height adjustment functionality

Height adjustment	Answer questions with yes (✓) or no (–)											
Date (please enter month/year)												
Acoustic signal sounds when height is adjusted?												
Height adjustment works without jolting, without slumping and without atypical running noises (e.g. clacking, scuffing)?												
Does the height setting remain the same even after the system has been switched off for a longer period of time?												
No jerking at beginning of soft start after key is pressed?												
Soft start does not begin after key is pressed?												
No follow-up movement of height adjustment after height adjustment keys are released?												

If no š Inform your dealer.

2.12 Documenting your yearly inspection

The undersigned confirms that he/she has checked the unit for the above criteria and that he/she has informed the competent dealer in case of any defects.

Year	Inspection date:	Name:	Signature:
1.			
2.			
3.			
4.			
5.			
6.			
7.			
8.			
9.			
10.			
11.			
12.			
13.			
14.			

3 Safety-related checks by the service engineer in compliance with standard IEC 62353

3.1 General information for the service engineer

The **Service Manual for ORTHOPHOS XG** (order no. 59 38 399) is absolutely essential for performing safety-related checks, as the protective ground wire and device leakage current tests are described in this document.

Measurements

Switch the power OFF at the main switch of the building installation.

Select the correct current/voltage type and adjust the measuring range to match the expected readings.

Perform continuity tests only on units which are switched off.

ATTENTION



When opening the unit:

**Please observe the usual precautionary measures for handling printed circuit boards (ESD).
Touch a ground point to discharge static electricity before handling any components.**



ATTENTION



**If the dental treatment center does not pass the safety tests, it must not be operated any longer!
You must advise the user of this fact in your capacity as service engineer. Corresponding repair work by an authorized service engineer is required before putting the system into service again.**

NOTE



The safety checks correspond to the standard IEC 62353:2007 (DIN EN 62353/VDE 0751-1:2008).
If you use an automatic tester, you can program it according to these standards.

- Application components Type B
- Permanently attached unit
- Protection Class I

The measurements to be performed are complex and time-consuming.
Sirona therefore explicitly recommends using an automatic tester.

3.2 Intervals for safety-related checks

It is essential to perform safety checks aimed particularly at detecting electrical faults during **initial startup** and then **every 2 years**. All inspections and measurements are performed by the authorized service engineer. They are specified in the following.

Safety-related checks are performed on the following occasions:

- **Initial startup**
- **Regularly every 2 years**
- **After extensions/upgrades (conversion)**
- **After repair work**

3.3 Safety-related check

(see Service Manual, chapter on Maintenance)

Equipment safety		Answer questions with yes (✓) or no (–) Enter measured values						
Maintenance interval after X years	Initial startup	2	4	6	8	10	12	14
Date (please enter month/year)								
Ground wire test OK? Enter measured values:								
A and B (GNYE wire) Measured value less than 0.1 ohms								
A and C (2nd ground wire) Measured value less than 0.1 ohms								
A and D (housing DX32) Measured value less than 0.2 ohms								
A and E (tube assembly housing) Measured value less than 0.2 ohms								
Unit leakage current test OK, measured value less than 2 mA? Enter measured values:								

3.4 Documenting the safety-related check

The undersigned confirms that he/she has checked the unit for the above criteria.
 If any question is answered with No, the fault must be eliminated.

Date:		Engineer's name:		Signature:	
Date:		Engineer's name:		Signature:	
Date:		Engineer's name:		Signature:	
Date:		Engineer's name:		Signature:	
Date:		Engineer's name:		Signature:	
Date:		Engineer's name:		Signature:	
Date:		Engineer's name:		Signature:	
Date:		Engineer's name:		Signature:	

4 Maintenance by the service engineer

4.1 General information for the service engineer

The **Service Manual for ORTHOPHOS XG** (order no. 59 38 399) is absolutely essential for performing maintenance, as all of the maintenance required is described therein. Furthermore, the operating instructions supplied with the unit are required.

Measurements

Always switch the unit OFF before connecting the measuring instruments.

Select the correct current/voltage type and adjust the measuring range to match the expected readings.

Perform continuity tests only on units which are switched off.

If several exposures with radiation must be taken to check a measurement, make sure that the prescribed cool-down intervals are observed.

ATTENTION



Observe the radiation protection guidelines before releasing radiation.

ATTENTION



When opening the unit:

Please observe the usual precautionary measures for handling printed circuit boards (ESD). Touch a ground point to discharge static electricity before handling any components.



Before starting maintenance work, always perform a functional test and advise the customer or dental practice staff about any defects found.

Should it be necessary to replace defective components along with parts subject to wear, this must be agreed previously with the customer or dental practice staff.

If components bearing a serial number are replaced, the new serial number must be recorded in the table in Chapter 4.5, "Serial numbers of the system".

Discontinuation of spare part deliveries:

Deliveries of spare parts are discontinued after a certain period of time for every system. The system owner will be responsible for safety-relevant failures of systems which continue in operation after that time and can no longer be serviced due to missing spare parts.

4.2 Maintenance interval



NOTE

In addition to the annual inspections to be carried out by the system owner or authorized persons, safety-related checks must be performed by the service engineer after 4, 7 and 10 years, and then at two-year intervals.

4.3 Checking the records

In the chapter "Annual inspection performed by the system owner or other authorized persons" on page 6 and in the chapter "Safety-related checks by the service engineer in compliance with standard IEC 62353" on page 15

Checking the records	Answer questions with yes (✓) or no (–)									
Maintenance interval (after years)	4	7	10	12	14					
Date (enter month/year)										
Annual inspection performed by the system owner (see Chapter 2)?										
Records complete?										
All questions answered with yes ?										
All work required due to a negative result during the checks has been performed?										
Have all safety-related checks been carried out and did the measured values remain constant?										

If no ⇒ Perform annual inspection prior to maintenance.

4.4 Labels on the system

Comparing labels on the system with Installation Report / Warranty Passport		Answer questions with yes (✓) or no (–)								
Maintenance interval (after years)	4	7	10	12	14					
Date (enter month/year)										
All labels according to Installation Report / Warranty Passport affixed ?										
All labels legible?										

If no ⇒ Replace missing and/or illegible labels.

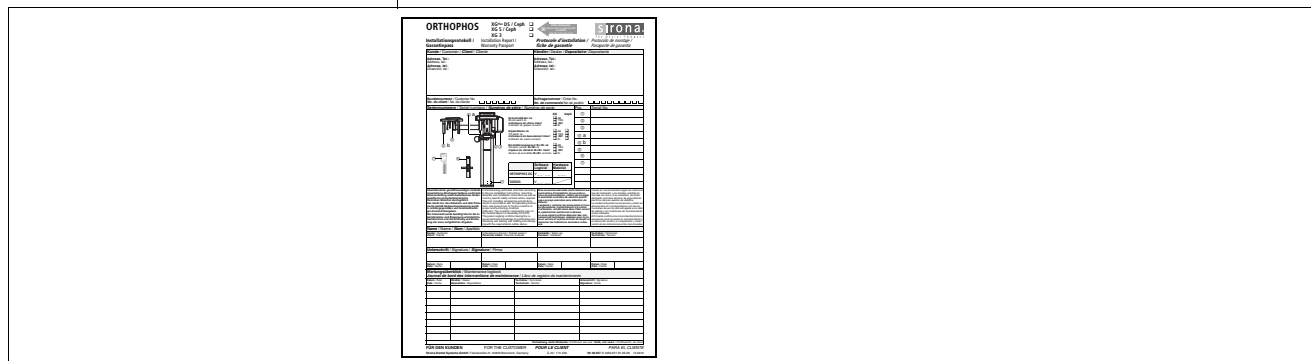

4.5 Serial numbers of the system

Please enter new Serial No. here when replacing a component:			
X-ray unit		Date	Signature
Serial No. (at initial start-up)			
Serial No.			
Serial No.			
X-ray tube assembly		Date	Signature
Serial No. (at initial start-up)			
Serial No.			
Serial No.			
Serial No.			
Serial No.			
Tube		Date	Signature
Serial No. (at initial start-up)			
Serial No.			
Serial No.			
Serial No.			
Serial No.			
Remote		Date	Signature
Serial No. (at initial start-up)			
Serial No.			
Serial No.			
Serial No.			
Ceph		Date	Signature
Serial No. (at initial start-up)			
Serial No.			
Serial No.			
Sensor		Date	Signature
Serial No. (at initial start-up)			
Serial No.			
Serial No.			
Cephalometer sensor		Datum	Unterschrift
Serial-No. (at initial start-up)			
Serial-No.			
Serial-No.			
Test phantom		Date	Signature
Serial No. (at initial start-up)			
Serial No.			
Serial No.			

4.6 Functional test

Prior to starting with maintenance work, a functional test must always be performed.

In doing so, it is helpful to read out the error messages, if present.

Refer to Chapter 5.1, "Selecting Service routines".

Inform the customer or dental practice staff about any defects you have detected.

Checking the system functions (observe Operating Instructions)		Answer questions with yes (✓) or no (–)								
Maintenance interval (after years)	4	7	10	12	14					
Date (enter month/year)										
No visible signs of abrasion or hardened grease on HV motor and threaded rod? See Service Manual										
No atypical running noises audible during height adjustment?										
Jolt-free fine positioning possible during height adjustment?										
Is there still enough lubricant between the sliding surfaces?										
Does the height setting remain the same even after the system has been switched off for a longer period of time?										
Is the limit switch for height adjustment functional?										
Acoustic signals audible during height adjustment?										
Forehead support can be moved easily and without jolting through the entire range? See Service Manual										
Temple supports can be adjusted easily and symmetrically?										
Rotating element No abrasion or hardened grease visible in the vicinity of the two actuators and the axis unit?										
Sensor Pan Sensor can be moved in and out easily and fits snugly in its guide? See Service Manual.										
Bite block/contact segment/chin rest in the bite block holder securely mounted?										
Light localizer adjustable?										
Sensor Ceph Sensor can be moved in and out easily and fits snugly in its guide?										
Ceph light localizer OK? See Service Manual										
	If no ⇔ Correct fault.									

4.7 Assessing X-ray exposures

Ask to be shown the most recent X-ray exposures taken by the dentist.

Assessing X-ray exposures		Answer questions with yes (✓) or no (-)									
Maintenance interval (after years)	4	7	10	12	14						
Date (enter month/year)											
Unexposed surrounding border present? See Service Manual											
Exposure sharp?											
Density of X-ray image OK ?											
If no ⇒ Correct fault.											

4.8 Checking the tube data

Checking the tube data		Answer questions with yes (✓) or no (-)									
Maintenance interval (after years)	4	7	10	12	14						
Date (enter month/year)											
Actual kV/mA values OK? See Service Manual											
Fan working?											
Does the temperature sensor in the tube assembly indicate a value between ca. 18° and 65°C?											
If no ⇒ Correct fault.											

4.9 Diaphragm check

Perform diaphragm check also with Cephalometer, if present.

Performing diaphragm check		Answer questions with yes (✓) or no (-)									
Maintenance interval (after years)	4	7	10	12	14						
Date (enter month/year)											
Test phantom exposure/needle phantom exposure correct? See Service Manual											
		If no ⇒ Correct fault.									

4.10 Checking the cables for damage

Checking the cables		Answer questions with yes (✓) or no (-)									
Maintenance interval (after years)	4	7	10	12	14						
Date (enter month/year)											
Power cable OK? See Service Manual											
Protective ground wire OK?											
Control cable OK?											
Data transfer cable OK?											
		If no ⇒ Correct fault.									

4.11 Safety checks

Move unit to working height. Switch power OFF at the main switch for the building installation.
Remove covers from the unit.

Performing safety checks		Answer questions with yes (✓) or no (–)									
Maintenance interval (after years)	4	7	10	12	14						
Date (enter month/year)											
Idling roll free of damage? See Service Manual											
Do grounding straps and cable shields have complete and firm contact? See Service Manual											
Cable shielding OK? See Service Manual											
Protective ground wire connections properly attached? See Service Manual											
If no ⇒ Correct fault.											

4.12 Final work

Final work (observe Operating Instructions)		Answer questions with yes (✓) or no (–)									
Maintenance interval (after years)	4	7	10	12	14						
Date (enter month/year)											
System cleaned?											
If no ⇒ Clean system.											

Space for remarks

We reserve the right to make any alterations which may be required due to technical improvements.

© Sirona Dental Systems GmbH 2015
D 3352.105.01.11.02 10.2015

Sprache: englisch
Ä.-Nr.: 121 125

Printed in Germany
Imprimé en Allemagne

Sirona Dental Systems GmbH

Fabrikstraße 31
D-64625 Bensheim
Germany
www.sirona.de

in the USA:

Sirona Dental Systems LLC
4835 Sirona Drive, Suite 100
Charlotte, NC 28273
USA

Order No **59 87 685 D 3352**